

GD54/74HC534, GD54/74HCT534

OCTAL 3-STATE INVERTING D-TYPE FLIP-FLOPS

General Description

These devices are identical in pinout to the 54/74LS534. They contain eight D-type master/slave flip-flops with a common clock and clear. Data meeting the setup and hold time requirements are transferred to the 3-state outputs on the rising edge of the clock pulse. The output enable input does not affect the states of the flip-flops, but when output enable is high, the outputs are forced to the high impedance state. Data may thus be stored even when the device is not selected. The HC/HCT 534 are identical in function to the HC/HCT 564 which have the input pins on the opposite side of the package from the output pins. They are similar in function to the HC/HCT 374 which have noninverting outputs. These devices are characterized for operation over wide temperature ranges to meet industry and military specifications.

Pin Configuration

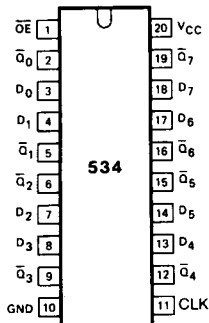

Suffix-Blank : Plastic Dual In Line Package
 Suffix-J : Ceramic Dual In Line Package
 Suffix-D : Small Outline Package

Features

- Low Power consumption characteristic of CMOS devices
- Output drive capability: 10 LS TTL Loads Min
- Operating speed superior to LS TTL
- Wide operating voltage range: for HC 2 to 6 volts
for HCT 4.5 to 5.5 volts
- Low input current: 1 μ A Max.
- Low quiescent current: 80 μ A Max. (74HC)
- High noise immunity characteristic of CMOS
- Diode protection on all inputs

Function Table

OPERATING MODES	INPUTS			INTERNAL FLIP-FLOPS	OUTPUT
	OE	CLK	D _n		Q ₀ to Q ₇
load and read register	L	↑	l	L	H
	L	↑	h	H	L
load register and disable outputs	H	↑	l	L	Z
	H	↑	h	H	Z

H = HIGH voltage level
 h = HIGH voltage level one set-up time prior to the LOW-to-HIGH CLK transition
 L = LOW voltage level
 l = LOW voltage level one set-up time prior to the LOW-to-HIGH CLK transition
 Z = high impedance OFF-state
 ↑ = LOW-to-HIGH clock transition

Absolute Maximum Ratings

SYMBOL	PARAMETER	CONDITIONS	MIN.	MAX.	UNIT
V_{CC}	DC Supply voltage		-0.5	+7	V
I_{IK}, I_{OK}	DC input or output diode current	for $V_I < -0.5$ or $V_I > V_{CC} + 0.5V$		20	mA
I_O	DC output source or sink current	for $-0.5V < V_O < V_{CC} + 0.5V$		35	mA
I_{CC}	DC V_{CC} or GND current			70	mA
T_{stg}	Storage temperature range		-65	150	°C
P_D	Power dissipation per package	above +70°C: derate linearly with 8mW/K		500	mW
T_L	Lead temperature	At distance $1/16 \pm 1/32$ in. from case for 60 sec(CERAMIC) 10 sec(PLASTIC)		300 260	°C

Recommended Operating Conditions

CHARACTERISTIC	LIMITS		UNITS
	MIN.	MAX.	
Supply-Voltage Range V_{CC} : GD54/74HC Types GD54/74HCT Types	2 4.5	6 5.5	V
DC Input or Output Voltage V_I, V_O	0	V_{CC}	V
Operating Temperature T_A : GD74 Types GD54 Types	-40 -55	+85 +125	°C
Input Rise and Fall times t_r, t_f : GD54/74HC Types at 2V at 4.5V at 6V GD54/74HCT Types at 4.5V		1000 500 400 500	ns

Logic Diagram

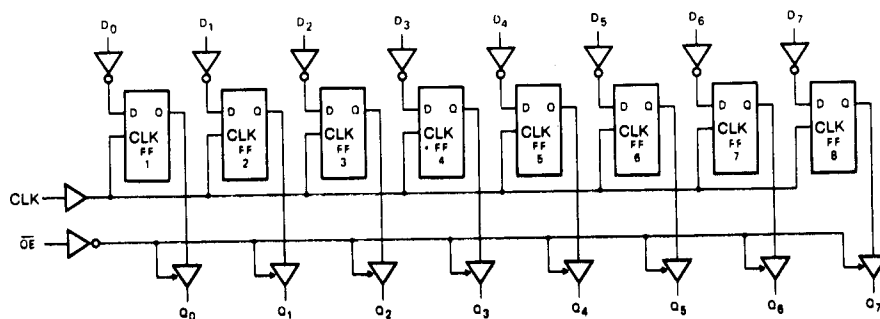

Fig. 1 Logic diagram.

DC Electrical Characteristics for HC

SYMBOL	PARAMETER	TEST CONDITION	V _{CC} (V)	T _A =25°C			GD74HC534		GD54HC534		UNIT
				MIN.	TYP.	MAX.	MIN.	MAX.	MIN.	MAX.	
V _{IH}	HIGH level input Voltage		2.0 4.5 6.0	1.5 3.15 4.2			1.5 3.15 4.2		1.5 3.15 4.2		V
V _{IL}	LOW level input voltage		2.0 4.5 6.0			0.3 0.9 1.2		0.3 0.9 1.2		0.3 0.9 1.2	V
V _{OH}	HIGH level output voltage	V _{IN} =V _{IH} or V _{IL}	I _{OH} = -20μA	2.0 4.5 6.0	1.9 4.4 5.9	2.0 4.5 6.0		1.9 4.4 5.9		1.9 4.4 5.9	V
			I _{OH} = -6mA I _{OH} = -7.8mA	4.5 6.0	3.98 5.48	4.3 5.2		3.84 5.34		3.7 5.2	
V _{OL}	LOW level output voltage	V _{IN} =V _{IH} or V _{IL}	I _{OL} =20μA	2.0 4.5 6.0			0.1 0.1 0.1		0.1 0.1 0.1	0.1 0.1 0.1	V
			I _{OL} =6mA I _{OL} =7.8mA	4.5 6.0		0.17 0.15	0.26 0.26		0.33 0.33	0.4 0.4	
I _{IN}	Input leakage Current	V _{IN} =V _{CC} or GND	6.0			0.1		1.0		1.0	μA
I _{OZ}	Three-State leakage current	V _{IN} =V _{IH} or V _{IL} V _O =V _{CC} or GND	6.0		0.01	0.5		5.0		10.0	μA
I _{CC}	Quiescent Supply Current	V _{IN} =V _{CC} or GND I _{out} =0μA	6.0			8		80		160	μA

DC Electrical Characteristics for HCT

SYMBOL	PARAMETER	TEST CONDITION	V _{CC} (V)	T _A =25°C			GD74HCT534		GD54HCT534		UNIT
				MIN.	TYP.	MAX.	MIN.	MAX.	MIN.	MAX.	
V _{IH}	HIGH level input Voltage		4.5 to 5.0	2.0			2.0		2.0		V
V _{IL}	LOW level input voltage		4.5 to 5.5			0.8		0.8		0.8	V
V _{OH}	HIGH level output voltage	V _{IN} =V _{IH} or V _{IL}	I _{OH} = -20μA	4.5	4.4	4.5		4.4		4.4	V
			I _{OH} = -6mA	4.5	3.98	4.3		3.84		3.7	
V _{OL}	LOW level output voltage	V _{IN} =V _{IH} or V _{IL}	I _{OL} =20μA	4.5			0.1		0.1	0.1	V
			I _{OL} =6mA	4.5		0.17	0.26		0.33	0.4	
I _{IN}	Input leakage Current	V _{IN} =V _{CC} or GND	5.5			0.1		1.0		1.0	μA
I _{O7}	Three-State leakage current	V _{IN} =V _{IH} or V _{IL} V _O =V _{CC} or GND	5.5		0.01	0.5		5.0		10.0	μA
I _{CC}	Quiescent Supply Current	V _{IN} =V _{CC} or GND I _{out} =0μA	5.5			8		80		160	μA

GD54/74HC534, GD54/74HCT534

Timing Requirements for HC: $t_r=t_f=6\text{ns}$ $C_L=50\text{ pF}$

SYMBOL	PARAMETER		V_{CC} (V)	$T_A=25^\circ\text{C}$			GD74HC534		GD54HC534		UNIT
				MIN.	TYP.	MAX.	MIN.	MAX.	MIN.	MAX.	
t_w	Pulse width	CLK high or low	2.0	80	30		100		120		ns
			4.5	16	10		20		25		
			6.0	14	8		18		22		
t_{su}	Setup time	Data before CLK \uparrow	2.0	60	30		100		120		ns
			4.5	12	10		20		25		
			6.0	10	8		18		22		
t_h	Hold time	Data after CLK \uparrow	2.0	3	0		3		3		ns
			4.5	3	0		3		3		
			6.0	3	0		3		3		

AC Characteristics for HC: $t_r=t_f=6\text{ns}$ $C_L=50\text{ pF}$

SYMBOL	PARAMETER		V_{CC} (V)	$T_A=25^\circ\text{C}$			GD74HC534		GD54HC534		UNIT
				MIN.	TYP.	MAX.	MIN.	MAX.	MIN.	MAX.	
f_{max}	Maximum Clock Pulse Frequency		2.0	6	20		5		4		MHz
			4.5	30	65		25		20		
			6.0	35	75		30		25		
$t_{PLH}/$ t_{PHL}	Propagation Delay Time CLK to \bar{Q}_n		2.0		40	140		180		210	ns
			4.5		14	28		36		40	
			6.0		12	26		33		38	
$t_{PZH}/$ t_{PZL}	3-state Output Enable Time \bar{OE} to \bar{Q}_n		2.0		38	140		180		210	ns
			4.5		13	28		36		40	
			6.0		12	26		33		38	
$t_{PLZ}/$ t_{PHZ}	3-state Output disable time \bar{OE} to \bar{Q}_n		2.0		38	140		180		210	ns
			4.5		13	28		30		40	
			6.0		12	26		33		38	
$t_{TLH}/$ t_{THL}	Output Transition Time		2.0		15	60		75		90	ns
			4.5		6	12		15		18	
			6.0		5	10		13		15	

Timing Requirements for HCT: $t_r = t_f = 6\text{ns}$ $C_L = 50\text{pF}$

SYMBOL	PARAMETER		V _{CC} (V)	T _A =25°C			GD74HCT534		GD54HCT534		UNIT
				MIN.	TYP.	MAX.	MIN.	MAX.	MIN.	MAX.	
t _w	Pulse width	CLK high or low	4.5	16	10		20		25		ns
t _{su}	Setup time	Data before CLK†	4.5	12	10		20		25		ns
t _h	Hold time	Data after CLK†	4.5	3	0		3		3		ns

AC Characteristics for HCT: $t_r = t_f = 6\text{ns}$ $C_L = 50\text{pF}$

SYMBOL	PARAMETER		V _{CC} (V)	T _A =25°C			GD74HCT534		GD54HCT534		UNIT
				MIN.	TYP.	MAX.	MIN.	MAX.	MIN.	MAX.	
f _{max}	Maximum Clock Pulse Frequency		4.5	27	54		22		18		MHz
t _{PLH} / t _{PHL}	Propagation Delay Time CLK to \overline{Q}_n		4.5		16	30		38		44	ns
t _{PZH} / t _{PZL}	3-state Output Enable Time \overline{OE} to \overline{Q}_n		4.5		15	30		38		45	ns
t _{PLZ} / t _{PHZ}	3-state Output Disable Time \overline{OE} to \overline{Q}_n		4.5		15	30		38		45	ns
t _{TLH} / t _{THL}	Output Transition Time		4.5		6	12		15		18	ns

AC Waveforms

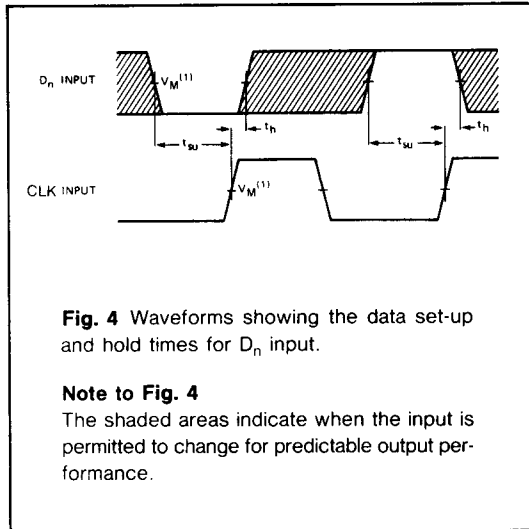
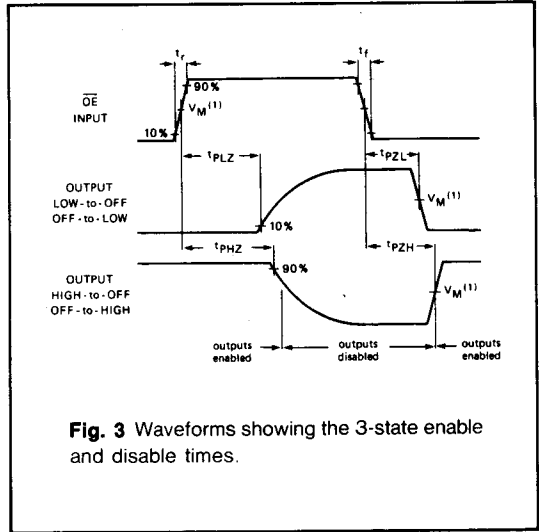
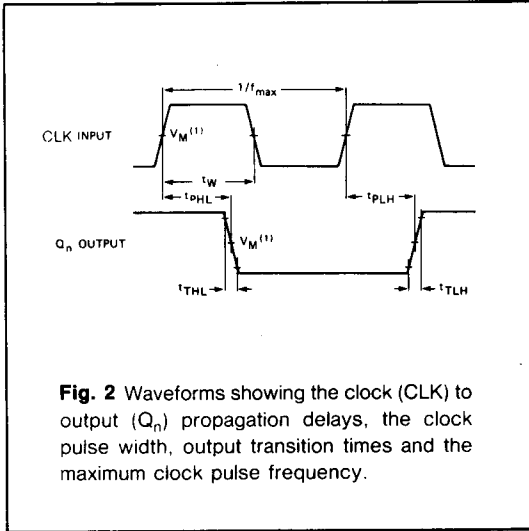

Note to AC waveforms

- (1) HC : $V_M = 50\%$; $V_i = \text{GND to } V_{CC}$
- HCT : $V_M = 1.3V$; $V_i = \text{GND to } 3V$.