

Description

The GM71C1000B/BL is the new generation dynamic RAM organized 1,048,576 x 1 bit. GM71C1000B/BL has realized higher density, higher performance and various functions by utilizing advanced CMOS process technology. The GM71C1000B/BL to be packaged in a standard 18 pin DIP, 20 pin SOJ and ZIP. The package size provides high system bit densities and is compatible with widely available automated testing and insertion equipment. System oriented features include single power supply of $5V \pm 10\%$ tolerance, direct interfacing capability with high performance logic families such as Schottky TTL.

Features

- 1,048,576 Words x 1 Bit Organization
- Fast Page Mode Capability
- Single Power Supply ($5V \pm 10\%$)
- Fast Access Time & Cycle Time

(Unit: ns)

	t _{RAC}	t _{CAC}	t _{RC}	t _{PC}
GM71C1000B/BL-60	60	20	120	40
GM71C1000B/BL-70	70	20	130	50
GM71C1000B/BL-80	80	25	160	55

- Low Power
Active : 495/440/385mW (MAX)
Standby : 5.5mW (CMOS level : MAX)
1.1mW (L-series)
- $\overline{\text{RAS}}$ Only Refresh, $\overline{\text{CAS}}$ before $\overline{\text{RAS}}$ Refresh, Hidden Refresh Capability
- All inputs and outputs TTL Compatible
- 512 Refresh Cycles/8ms
- 512 Refresh Cycles/64ms (L-series)
- Battery Back Up Operation (L-series)

Pin Configuration

18 DIP

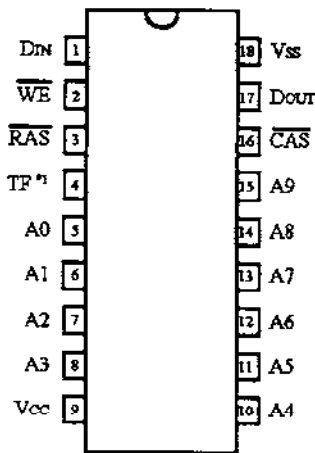

(Top View)

20 (26) SOJ

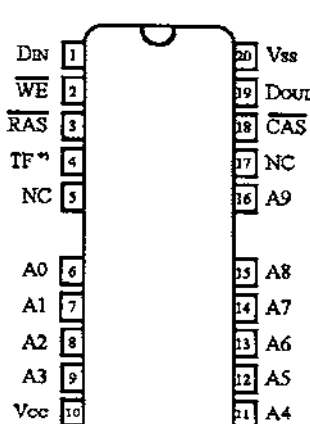

(Top View)

20 ZIP

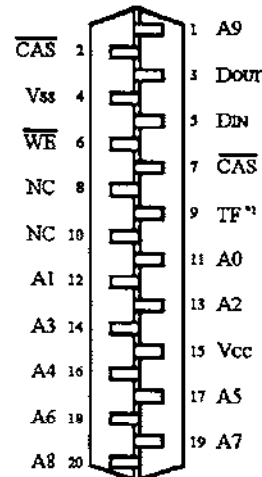

(Bottom View)

Pin Description

Pin	Function	Pin	Function
A0-A9	Address Inputs	D _{IN}	Data Input
$\overline{\text{RAS}}$	Row Address Strobe	V _{CC}	Power (+5V)
$\overline{\text{CAS}}$	Column Address Strobe	V _{SS}	Ground
$\overline{\text{WE}}$	Read/Write Enable	TF ^{*1}	Test Function
D _{OUT}	Data Output	NC	No Connection

Note *1. TF pin can be connected with any line or unconnected provided the voltage level of TF pin must be kept lower than V_{CC} + 0.5V.

Ordering Information

Type No.	Access Time	Package
GM71C1000B/BL-60 GM71C1000B/BL-70 GM71C1000B/BL-80	60 ns 70 ns 70 ns	300 Mil 18 Pin Plastic DIP
GM71C1000BJ/BLJ-60 GM71C1000BJ/BLJ-70 GM71C1000BJ/BLJ-80	60 ns 70 ns 70 ns	300 Mil 20 (26) Pin Plastic SOJ
GM71C1000BZ/BLZ-60 GM71C1000BZ/BLZ-70 GM71C1000BZ/BLZ-80	60 ns 70 ns 70 ns	400 Mil 20 Pin Plastic ZIP

Absolute Maximum Ratings*

Symbol	Parameter	Rating	Unit
T _A	Ambient Temperature under Bias	0 ~ 70	°C
T _{STG}	Storage Temperature (Plastic)	-55 ~ 125	°C
V _{IN} /V _{OUT}	Voltage on any Pin Relative to V _{SS}	-1.0 ~ 7.0	V
V _{CC}	Voltage on V _{CC} Relative to V _{SS}	-1.0 ~ 7.0	V
I _{OUT}	Short Circuit Output Current	50	mA
P _D	Power Dissipation	1.0	W

*Note: Operation at or above Absolute Maximum Ratings can adversely affect device reliability.

Recommended DC Operating Conditions (T_A = 0 ~ 70°C)

Symbol	Parameter	Min	Typ	Max	Unit
V _{CC}	Supply Voltage	4.5	5.0	5.5	V
V _{IH}	Input High Voltage	2.4	-	6.5	V
V _{IL}	Input Low Voltage	-1.0	-	0.8	V

DC Electrical Characteristics ($V_{CC} = 5V \pm 10\%$, $T_A = 0 \sim 70^\circ C$)

Symbol	Parameter	Min	Max	Unit	Note	
V_{OH}	Output Level Output "H" Level Voltage ($I_{OUT} = -5mA$)	2.4	V_{CC}	V		
V_{OL}	Output Level Output "L" Level Voltage ($I_{OUT} = 4.2mA$)	0	0.4	V		
I_{CC1}	Operating Current Average Power Supply Operating Current (RAS, CAS, Address Cycling: $t_{RC} = t_{RC\ min}$)	60ns	-	90	mA	1, 2
		70ns	-	80		
		80ns	-	70		
I_{CC2}	Standby Current (TTL) Power Supply Standby Current (RAS, CAS = V_{IH} , DOUT = High-Z)	-	2	mA		
I_{CC3}	RAS-Only Refresh Current Average Power Supply Current RAS-Only Refresh Mode (RAS Cycling, CAS = V_{IH} , $t_{RC} = t_{RC\ min}$)	60ns	-	90	mA	2
		70ns	-	80		
		80ns	-	60		
I_{CC4}	Fast Page Mode Current Average Power Supply Current Fast Page Mode (RAS = V_{IL} , CAS, Address Cycling: $t_{RC} = t_{RC\ min}$)	60ns	-	80	mA	1, 3
		70ns	-	70		
		80ns	-	50		
I_{CC5}	Standby Current (CMOS) Power Supply Standby Current (RAS, CAS $\geq V_{CC} - 0.2V$)	-	1	mA		
		-	200	μA	5	
I_{CC6}	CAS-before-RAS Refresh Current ($t_{RC} = t_{RC\ min}$)	60ns	-	80	mA	
		70ns	-	70		
		80ns	-	60		
I_{CC7}	Battery Back Up Current (Standby with CBR Refresh) ($t_{RC} = 125\mu s$, $t_{RAS} \leq 1\mu s$, $\overline{WE} = V_{IH}$, $\overline{CAS} = V_{IL}$, \overline{OE} , Address and $D_{IN} = V_{IH}$ or V_{IL} , DOUT = High-Z)	-	300	μA	4, 5	
I_{CC8}	Standby Current $\overline{RAS} = V_{IH}$ $CAS = V_{IL}$ DOUT = Enable	-	5	mA	1	
I_{IC}	Input Leakage Current Any Input ($0V \leq V_{IN} \leq 7V$)	-10	10	μA		
I_{OC}	Output Leakage Current (DOUT is Disabled, $0V \leq V_{OUT} \leq 7V$)	-10	10	μA		

- Note: 1. I_{CC} depends on output load condition when the device is selected. $I_{CC(max)}$ is specified at the output open condition.
 2. Address can be changed once or less while $\overline{RAS} = V_{IL}$.
 3. Address can be changed once or less while $\overline{CAS} = V_{IH}$.
 4. L Series.
 5. $t_{RAS(max)} = 1\mu s$ is applied to refresh of battery back up.

Capacitance ($V_{CC} = 5V \pm 10\%$, $T_A = 25^\circ C$)

Symbol	Parameter	Min	Max	Unit	Note
C_{II}	Input Capacitance (Address, D_{in})	-	5	pF	1
C_{I2}	Input Capacitance (Clocks)	-	7	pF	1
C_o	Output Capacitance (D_{out})	-	7	pF	1, 2

Note: 1. Capacitance measured with Boonton Meter or effective capacitance measuring method.
 2. CAS = V_{IH} to disable D_{out} .

AC Characteristics ($V_{CC} = 5V \pm 10\%$, $T_A = 0 \sim 70^\circ C$, Notes 1, 14)

Test Conditions

Input rise and fall times: 5 ns

Output load : 2 TTL gate + C_L (100pF)

Input, output timing reference levels: 0.8V, 2.4V

(Including scope and jig)

Read, Write, Read-Modify-Write and Refresh Cycles (Common Parameters)

Symbol	Parameter	GM71C1000 B/BL-60		GM71C1000 B/BL-70		GM71C1000 B/BL-80		Unit	Note
		Min	Max	Min	Max	Min	Max		
t_{RC}	Random Read or Write Cycle Time	120	-	130	-	160	-	ns	
t_{RP}	\overline{RAS} Precharge Time	50	-	50	-	70	-	ns	
t_{RAS}	\overline{RAS} Pulse Width	60	10,000	70	10,000	80	10,000	ns	
t_{CAS}	\overline{CAS} Pulse Width	20	10,000	20	10,000	25	10,000	ns	
t_{ASR}	Row Address Set-up Time	0	-	0	-	0	-	ns	
t_{RAH}	Row Address Hold Time	10	-	10	-	12	-	ns	
t_{ASC}	Column Address Set-up Time	0	-	0	-	0	-	ns	
t_{CAH}	Column Address Hold Time	15	-	15	-	20	-	ns	
t_{RCD}	\overline{RAS} to \overline{CAS} Delay Time	20	40	20	50	22	55	ns	8
t_{RAD}	\overline{RAS} to Column Address Delay Time	15	30	15	35	17	40	ns	9
t_{RSH}	\overline{RAS} Hold Time	20	-	20	-	25	-	ns	
t_{CSH}	\overline{CAS} Hold Time	60	-	70	-	80	-	ns	
t_{CRP}	\overline{CAS} to \overline{RAS} Precharge Time	10	-	10	-	10	-	ns	
t_T	Transition Time (Rise and Fall)	3	50	3	50	3	50	ns	7
t_{REF}	Refresh Period	-	8	-	8	-	8	ms	
	Refresh Period (L-Series)	-	64	-	64	-	64	ms	

Read Cycle

Symbol	Parameter	GM71C1000 B/BL-60		GM71C1000 B/BL-70		GM71C1000 B/BL-80		Unit	Note
		Min	Max	Min	Max	Min	Max		
t _{RAC}	Access Time from $\overline{\text{RAS}}$	-	60	-	70	-	80	ns	2, 3
t _{CAC}	Access Time from $\overline{\text{CAS}}$	-	20	-	20	-	25	ns	3, 4
t _{AA}	Access Time from Address	-	30	-	35	-	40	ns	3, 5
t _{RCS}	Read Command Setup Time	0	-	0	-	0	-	ns	
t _{RCH}	Read Command Hold Time to $\overline{\text{CAS}}$	0	-	0	-	0	-	ns	
t _{RRH}	Read Command Hold Time to $\overline{\text{RAS}}$	10	-	10	-	10	-	ns	
t _{RAL}	Column Address to $\overline{\text{RAS}}$ Lead Time	30	-	35	-	40	-	ns	
t _{OFF}	Output Buffer Turn-off Time	0	20	0	20	0	20	ns	6

Write Cycle

Symbol	Parameter	GM71C1000 B/BL-60		GM71C1000 B/BL-70		GM71C1000 B/BL-80		Unit	Note
		Min	Max	Min	Max	Min	Max		
t _{WCS}	Write Command Setup Time	0	-	0	-	0	-	ns	10
t _{WCH}	Write Command Hold Time	15	-	15	-	20	-	ns	
t _{WP}	Write Command Pulse Width	10	-	10	-	15	-	ns	
t _{RWL}	Write Command to $\overline{\text{RAS}}$ Lead Time	20	-	20	-	25	-	ns	
t _{CWL}	Write Command to $\overline{\text{CAS}}$ Lead Time	20	-	20	-	25	-	ns	
t _{DS}	Data-in Setup Time	0	-	0	-	0	-	ns	11
t _{DH}	Data-in Hold Time	15	-	15	-	20	-	ns	11

Read-Modify-Write Cycle

Symbol	Parameter	GM71C1000 B/BL-60		GM71C1000 B/BL-70		GM71C1000 B/BL-80		Unit	Note
		Min	Max	Min	Max	Min	Max		
t _{RWC}	Read-Modify-Write Cycle Time	145	-	155	-	190	-	ns	
t _{RWD}	$\overline{\text{RAS}}$ to $\overline{\text{WE}}$ Delay Time	60	-	70	-	80	-	ns	10
t _{CWD}	$\overline{\text{CAS}}$ to $\overline{\text{WE}}$ Delay Time	20	-	20	-	25	-	ns	10
t _{AWD}	Column Address to $\overline{\text{WE}}$ Delay Time	30	-	35	-	40	-	ns	10

Refresh Cycle

Symbol	Parameter	GM71C1000 B/BL-60		GM71C1000 B/BL-70		GM71C1000 B/BL-80		Unit	Note
		Min	Max	Min	Max	Min	Max		
t _{CSR}	$\overline{\text{CAS}}$ Set-up Time ($\overline{\text{CAS}}$ -before- $\overline{\text{RAS}}$ Refresh Cycle)	10	-	10	-	10	-	ns	
t _{CHR}	$\overline{\text{CAS}}$ Hold Time ($\overline{\text{CAS}}$ -before- $\overline{\text{RAS}}$ Refresh Cycle)	15	-	15	-	20	-	ns	
t _{RPC}	$\overline{\text{RAS}}$ Precharge to $\overline{\text{CAS}}$ Hold Time	10	-	10	-	10	-	ns	

Fast Page Mode Cycle

Symbol	Parameter	GM71C1000 B/BL-60		GM71C1000 B/BL-70		GM71C1000 B/BL-80		Unit	Note
		Min	Max	Min	Max	Min	Max		
t _{PC}	Fast Page Mode Cycle Time	45	-	50	-	55	-	ns	
t _{CP}	Fast Page Mode $\overline{\text{CAS}}$ Precharge Time	10	-	10	-	10	-	ns	
t _{RASC}	Fast Page Mode $\overline{\text{RAS}}$ Pulse Width	-	100,000	-	100,000	-	100,000	ns	12
t _{ACP}	Access Time from $\overline{\text{CAS}}$ Precharge	-	40	-	45	-	50	ns	13
t _{RHCP}	$\overline{\text{RAS}}$ Hold Time from $\overline{\text{CAS}}$ Precharge	40	-	45	-	50	-	ns	

Fast Page Mode Read-Modify-Write Cycle

Symbol	Parameter	GM71C1000 B/BL-60		GM71C1000 B/BL-70		GM71C1000 B/BL-80		Unit	Note
		Min	Max	Min	Max	Min	Max		
t _{PCM}	Fast Page Mode Read-Modify-Write Cycle Time	70	-	75	-	85	-	ns	

Notes:

1. AC Measurements assume $t_r = 5\text{ns}$.
2. Assumes that $t_{\text{rCD}} \leq t_{\text{rCD}}(\text{MAX})$ and $t_{\text{rAD}} \leq t_{\text{rAD}}(\text{MAX})$. If t_{rCD} OR t_{rAD} is greater than the maximum recommended value shown in this table, t_{rAC} exceeds the value shown.
3. Measured with a load circuit equivalent to 2TTL loads and 100pF .
4. Assumes that $t_{\text{rCD}} \geq t_{\text{rCD}}(\text{MAX})$ and $t_{\text{rAD}} \leq t_{\text{rAD}}(\text{MAX})$.
5. Assumes that $t_{\text{rCD}} \leq t_{\text{rCD}}(\text{MAX})$ and $t_{\text{rAD}} \geq t_{\text{rAD}}(\text{MAX})$.
6. $t_{\text{OFF}}(\text{MAX})$ defines the time at which the output achieves the open circuit condition and is not referenced to output voltage levels.
7. $V_{\text{IH}}(\text{MAX})$ and $V_{\text{IL}}(\text{MAX})$ are reference levels for measuring timing of input signals. Also, transition times are measured between V_{IH} and V_{IL} .
8. Operation with the $t_{\text{rCD}}(\text{MAX})$ limit insures that $t_{\text{rAC}}(\text{MAX})$ can be met, $t_{\text{rCD}}(\text{MAX})$ is specified as a reference point only; if t_{rCD} is greater than the specified $t_{\text{rCD}}(\text{MAX})$ limit, then access time is controlled exclusively by t_{CAC} .
9. Operation with the $t_{\text{rAD}}(\text{MAX})$ limit insures that $t_{\text{rAC}}(\text{MAX})$ can be met, $t_{\text{rAD}}(\text{MAX})$ is specified as a reference point only; if t_{rAD} is greater than the specified $t_{\text{rAD}}(\text{MAX})$ limit, then access time is controlled exclusively by t_{AA} .
10. t_{WCS} , t_{rWD} , t_{CWD} , t_{AWD} and t_{CPW} are not restrictive operating parameters. They are included in the data sheet as electrical characteristics only if $t_{\text{WCS}} \geq t_{\text{WCS}}(\text{MIN})$ the cycle is an early write cycle and the data out pin will remain open circuit (high impedance) throughout the entire cycle; if $t_{\text{rWD}} \geq t_{\text{rWD}}(\text{MIN})$, $t_{\text{CWD}} \geq t_{\text{CWD}}(\text{MIN})$, $t_{\text{AWD}} \geq t_{\text{AWD}}(\text{MIN})$ and $t_{\text{CPW}} \geq t_{\text{CPW}}(\text{MIN})$, the cycle is a read modify write and the data output will contain data read from the selected cell; if neither of the above sets of conditions is satisfied, the condition of the data out (at access time) is indeterminate.
11. These parameters are referenced to $\overline{\text{CAS}}$ leading edge in early write cycles and to $\overline{\text{WE}}$ leading edge in delayed write or a read modify write cycle.
12. t_{RASC} defines $\overline{\text{RAS}}$ pulse width in fast page mode cycles.
13. Access time is determined by the longer of t_{AA} OR t_{CAC} OR t_{ACP} .
14. An initial pause of $100\mu\text{s}$ is required after power up followed by a minimum of eight initialization cycles ($\overline{\text{RAS}}$ only refresh cycle or $\overline{\text{CAS}}$ -before- $\overline{\text{RAS}}$ refresh cycle). If the internal refresh counter is used, a minimum of eight $\overline{\text{CAS}}$ -before- $\overline{\text{RAS}}$ refresh cycles is required.

Timing Waveforms

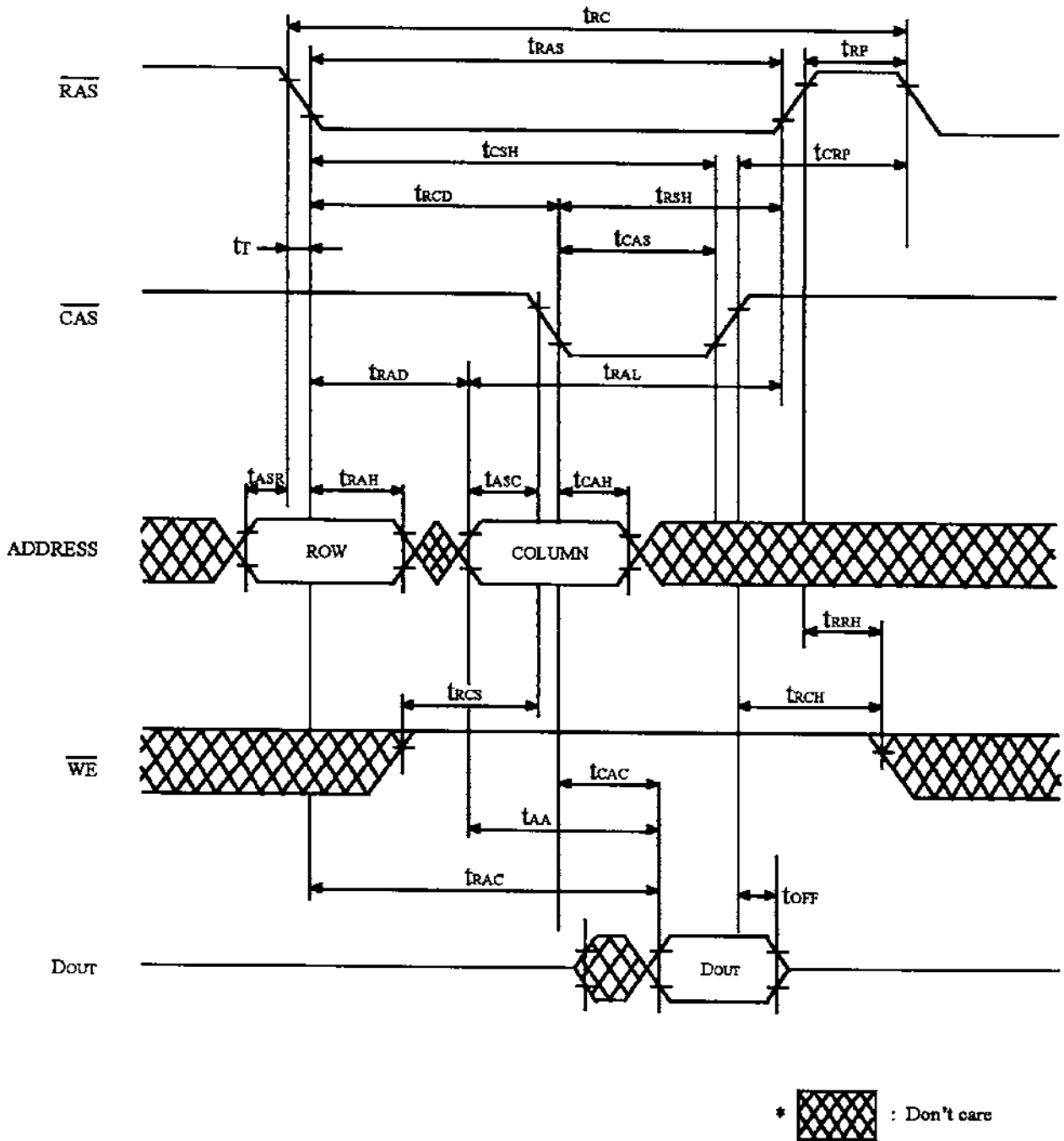
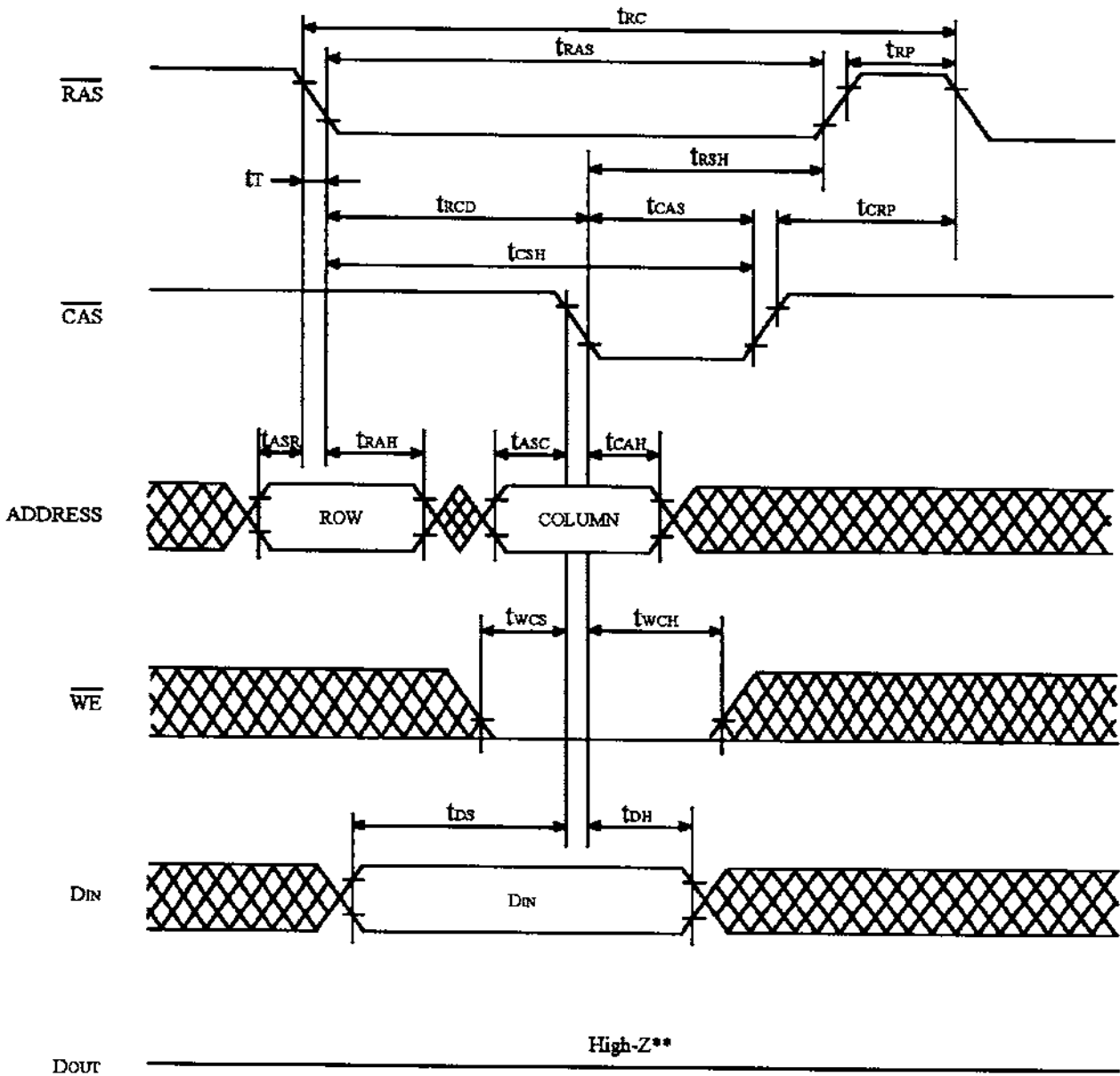



FIGURE 1. READ CYCLE



*  : Don't care

** $t_{WCS} \geq t_{WCS}(\text{min})$

FIGURE 2. EARLY WRITE CYCLE

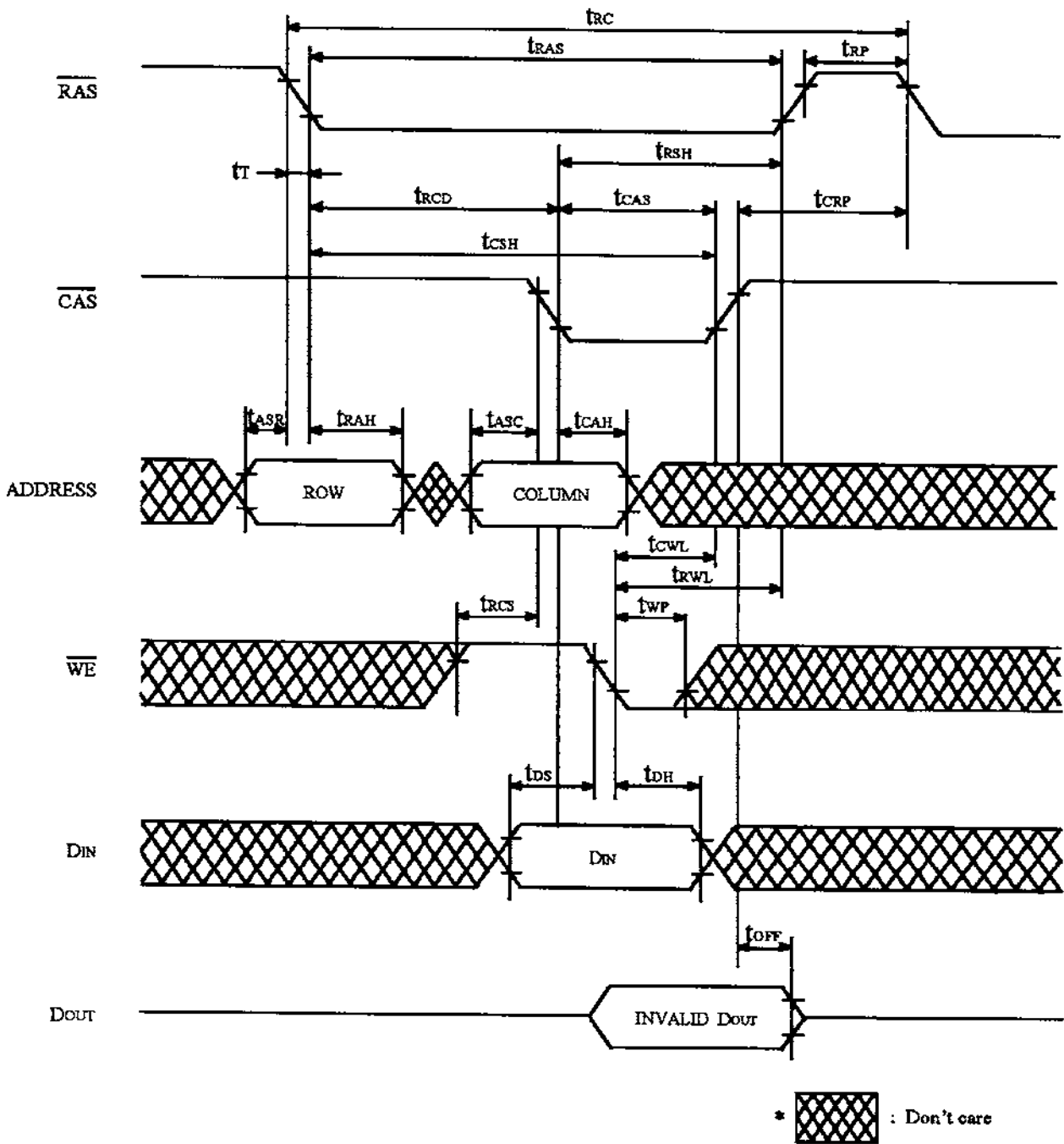

FIGURE 3. DELAYED WRITE CYCLE

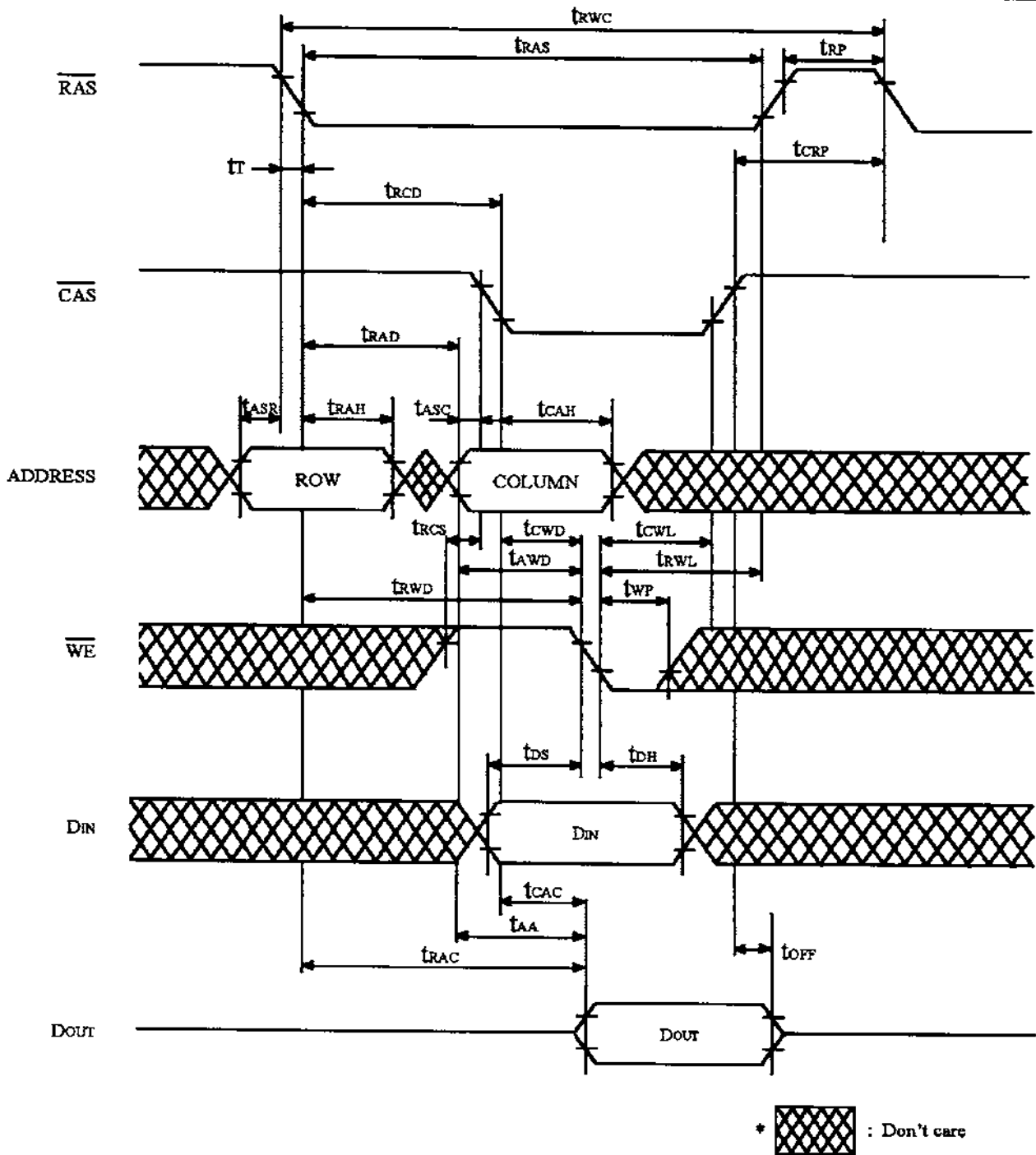

FIGURE 4. READ MODIFY WRITE CYCLE

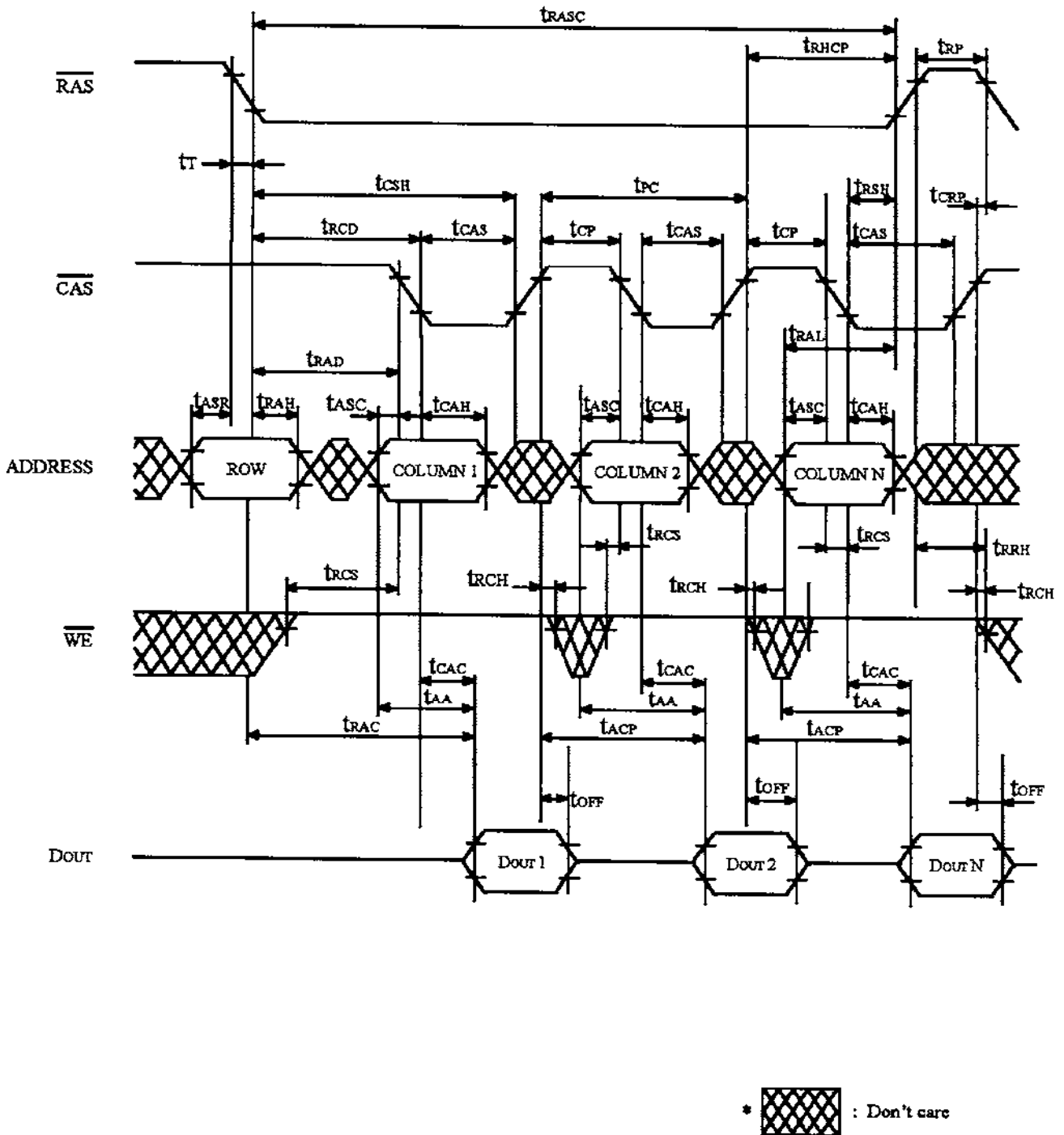
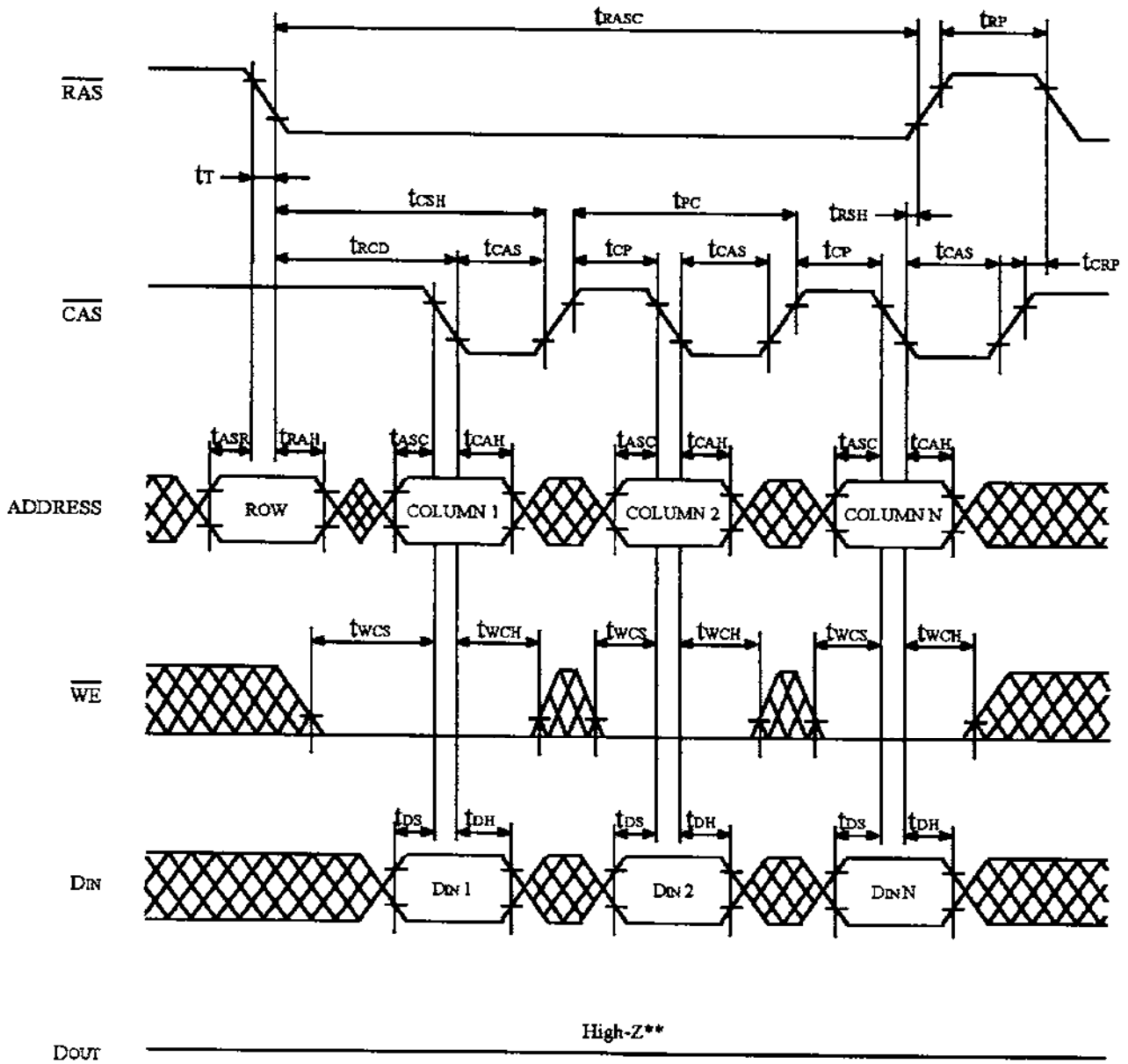



FIGURE 5. FAST PAGE MODE READ CYCLE



*  : Don't care

** $t_{\text{wcs}} \geq t_{\text{wcs}}(\text{min})$

FIGURE 6. FAST PAGE MODE EARLY WRITE CYCLE

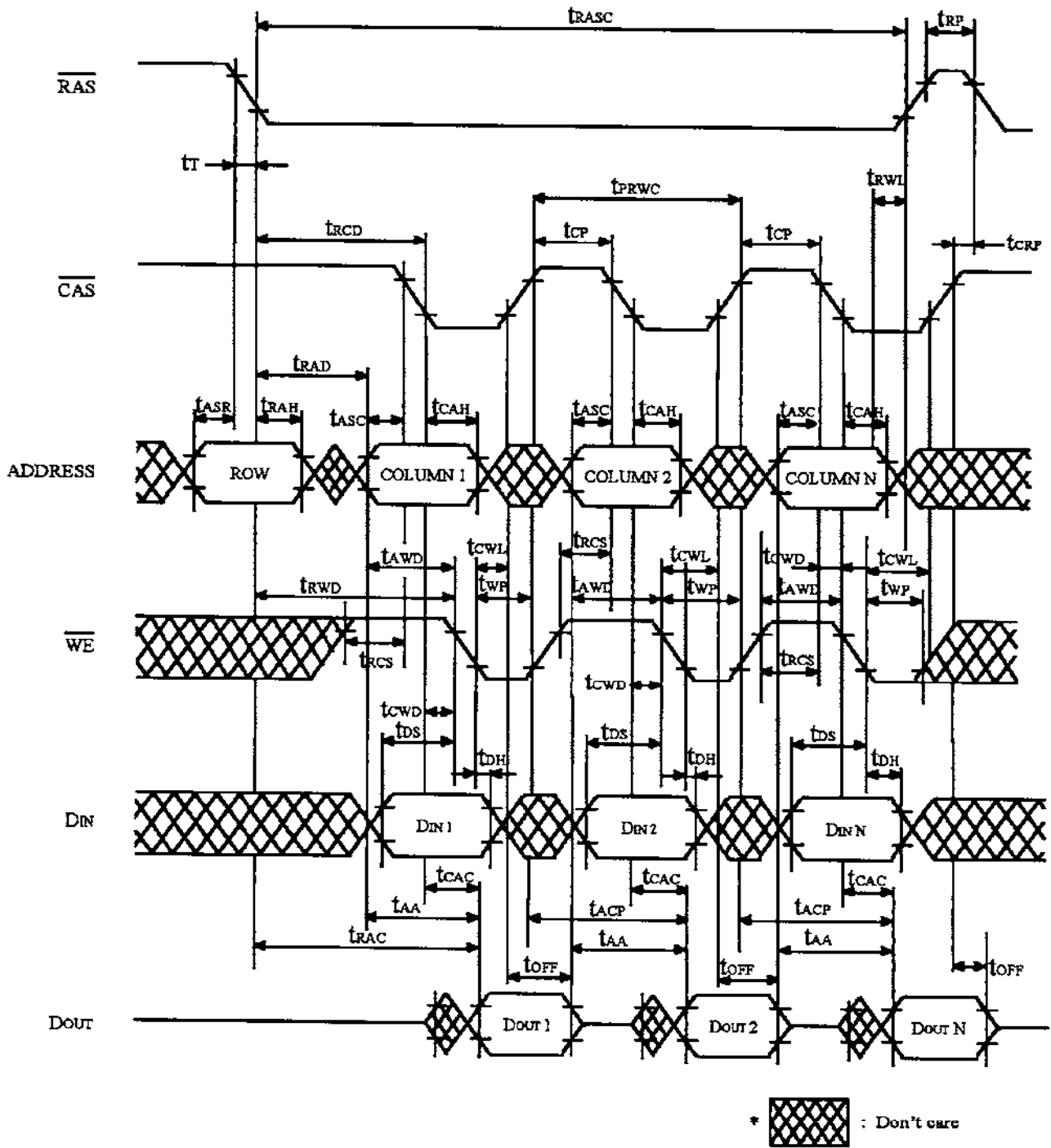

FIGURE 7. FAST PAGE MODE READ MODIFY WRITE CYCLE

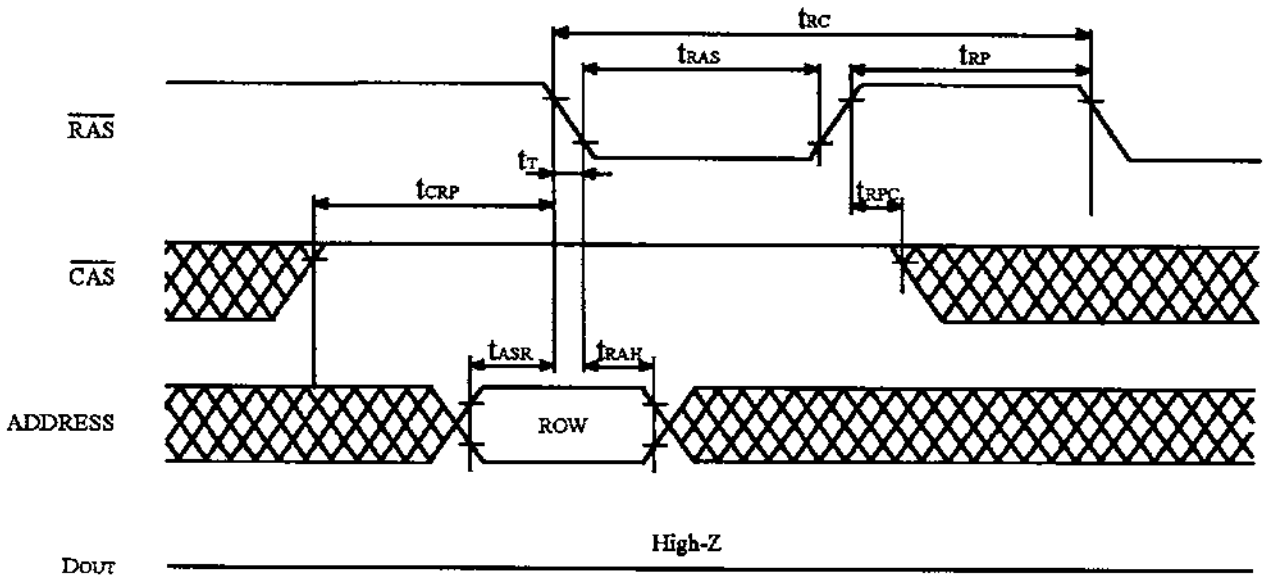

FIGURE 8. $\overline{\text{RAS}}$ ONLY REFRESH CYCLE

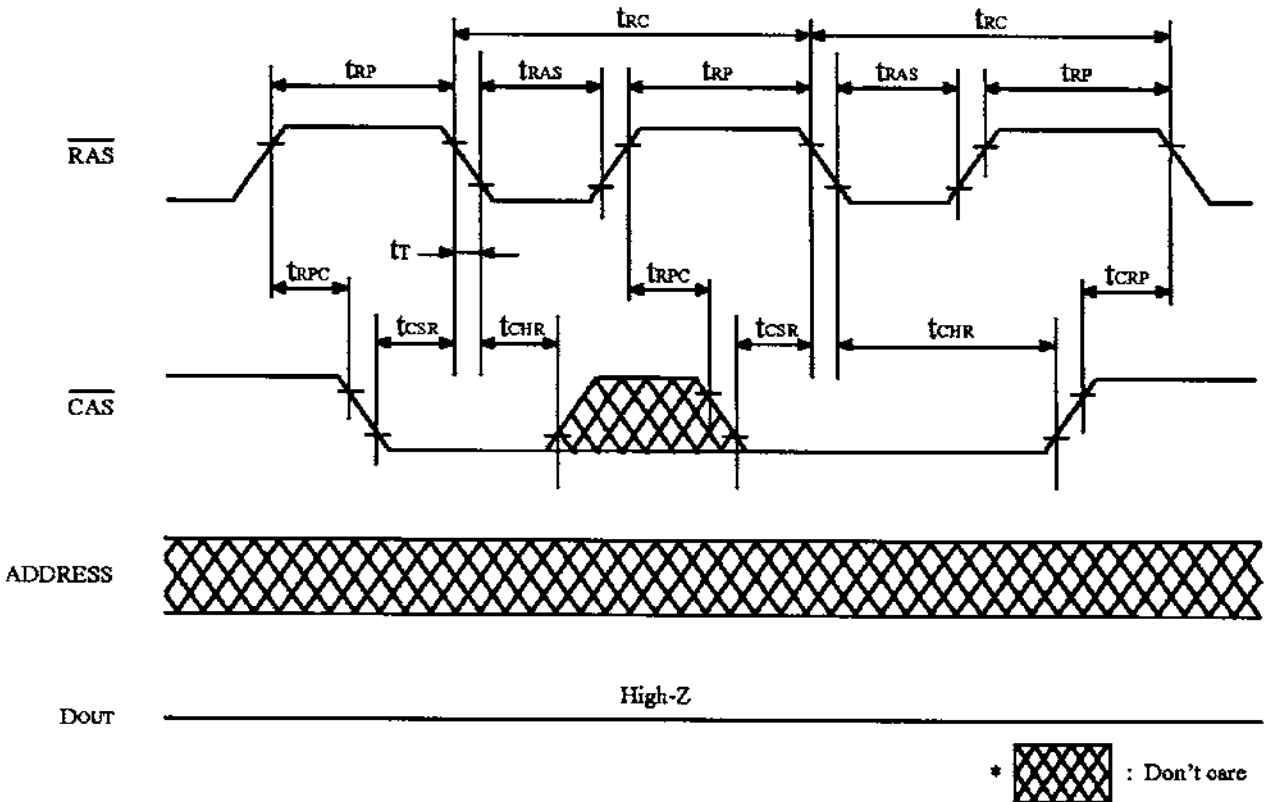
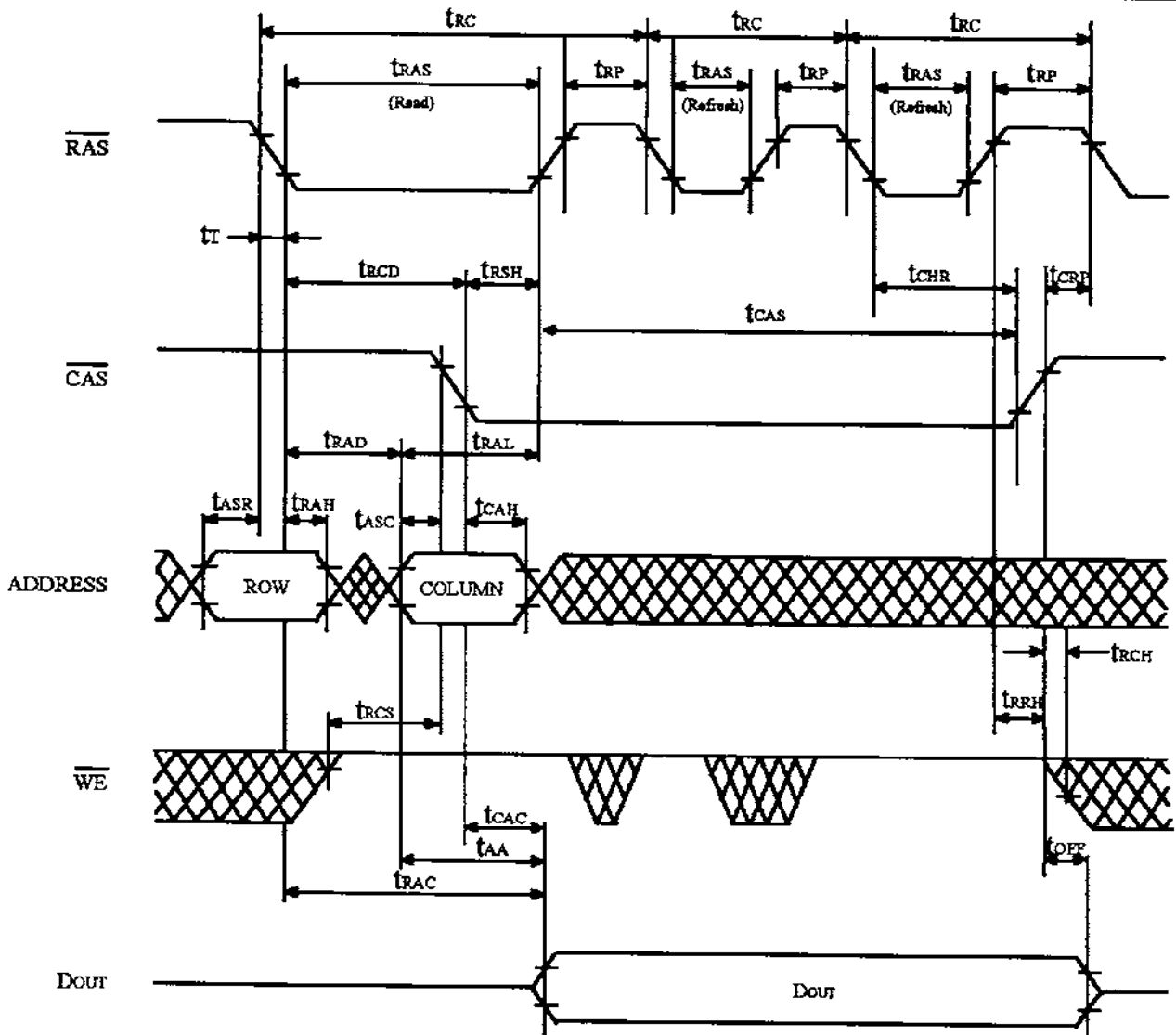

FIGURE 9. $\overline{\text{CAS}}$ BEFORE $\overline{\text{RAS}}$ REFRESH CYCLE



*  : Don't care

FIGURE 10. HIDDEN REFRESH CYCLE

Package Dimension

Unit: Inches (mm)

18 DIP

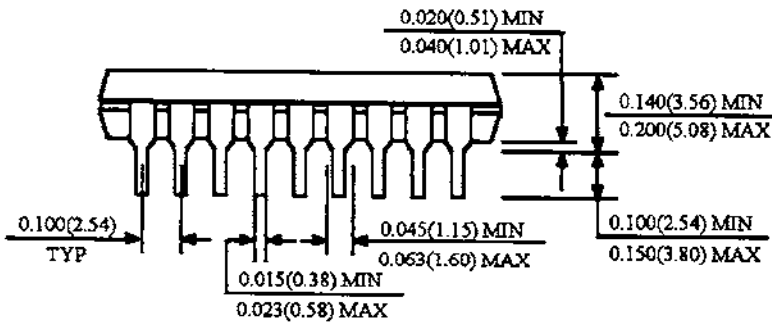
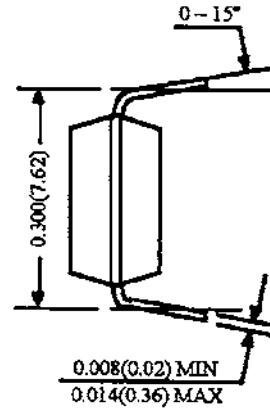
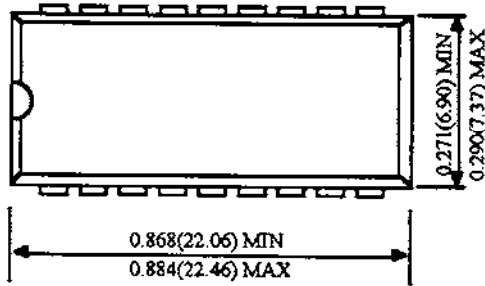

20 SOJ

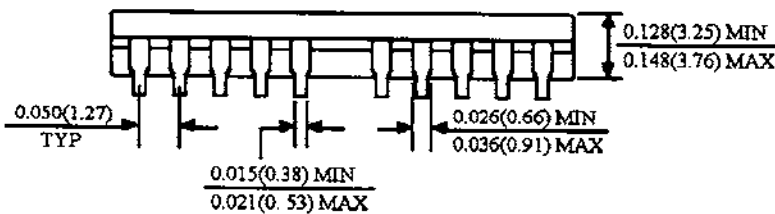
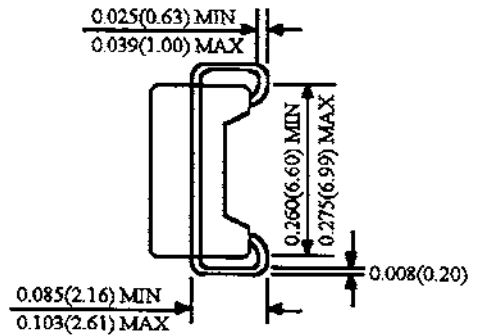
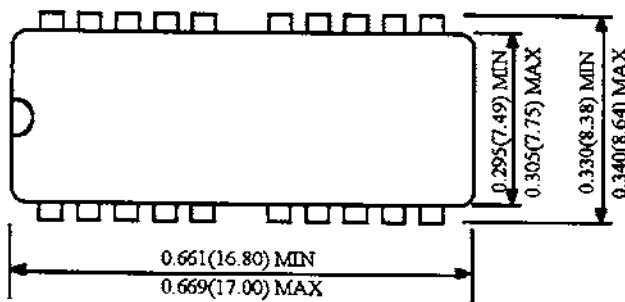

Package Dimension

Unit: Inches (mm)

20 ZIP

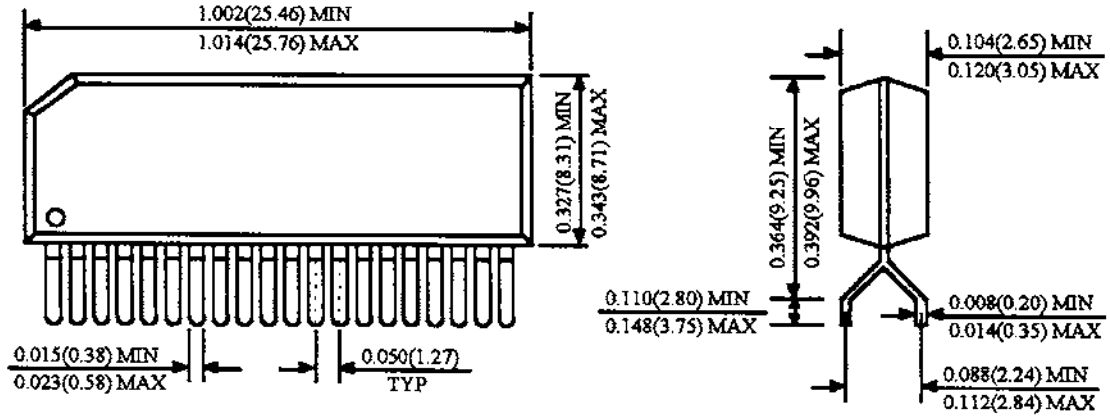

4