

Specific request can be addressed to RAKON-TEMEX marcomrakontemex@rakon.com

Features

- High selectivity
- Linear phase
- Fundamental mode or overtone 3 and 5
- Frequency Range: 3 to 150 MHz
- Relative Bandwidth: from 0.001 up to 1 %
- Insertion loss: 2 to 8 dB depending on frequency, number of poles and width
- 2 to 8 poles depending on the shape factor
- Max input power: up to + 5 dBm depending on the frequency
- Case types(s) : depending on number of poles
- Manufactured following the guidelines of MIL-PRF-55310 ... level S



Applications

- Receiver of satellite (Transponder)

Environmental conditions

Parameters	Unit	Minimum	Typical	Maximum
Operating temperature range	°C	- 20		+ 60
Storage temperature range	°C	- 40		+ 85
Shocks (half sine)		50g, 11ms all axis		
Sine vibration		20g as per MIL-STD-202, Method 204, Condition D		
Random vibration		50 Grms as per MIL-STD-202, Method 214, Condition A		
Thermal shock		MIL-STD-202, Method 107, Condition A1		
Radiation		Up to 100 kRad total dose		

Performance characteristics

Electrical Parameters	Unit	Minimum	Maximum
Frequency range (Fc)	MHz	5	150
Relative Bandwidth	%	0.0001	1
Insertion loss	dB	2	8
Ripple	dB		3
Shape factor (ratio of 60 to 3 dB bandwidth)		1.2	
Out of band rejection	dB	20	80
Impedance	Ω	50/50	

Mechanical characteristics

Example of package for 8 poles filter

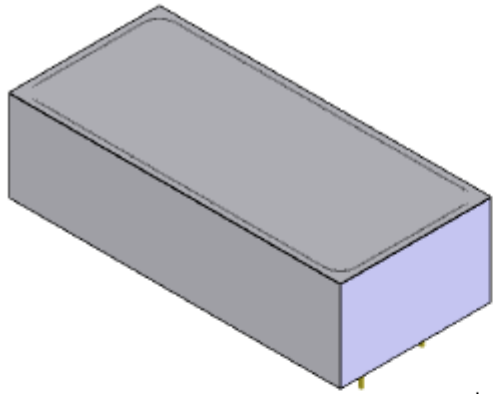

Pin Out	Designation
1	IN
2	OUT
3	GND

