

Chip Bead Cores

Type: **EXCCL**
EXCML
EXC3B



■ Features

- Effective noise suppression for power lines and high speed signal lines
- Easy pattern layout on PC Board
- For flow soldering and reflow soldering

Type: EXCCL, EXCML

- Low DC Resistance 3 to 8 mΩ typical: Rated current (3 and 4 Amperes) (type: EXCML)
- Low impedance

Type: EXC3B

- High impedance for high speed signal line noise
- Increased attenuation
- 60 Ω-1 A, 120 Ω-0.5 A are achieved by using 1608 size (type: EXC3BP)

■ Recommended Applications

- Digital equipment such as PCs, word processors, printers, HDD, PCC, CD-ROMs, DVD-ROMs.
- Digital audio and video equipment such as VCRs, DVC, CD Players, DVD Players.
- AC adapters, and switching power supplies.
- Electronic musical instruments, and other digital equipment.

■ Type: EXCCL

- Explanation of Part Numbers

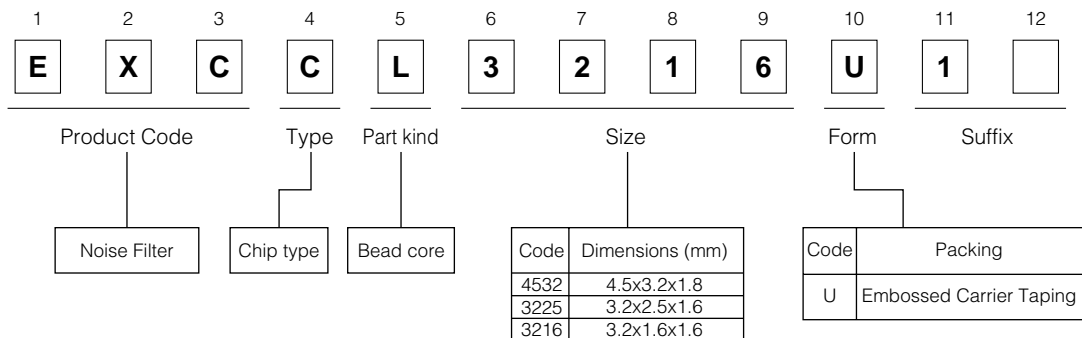

Construction

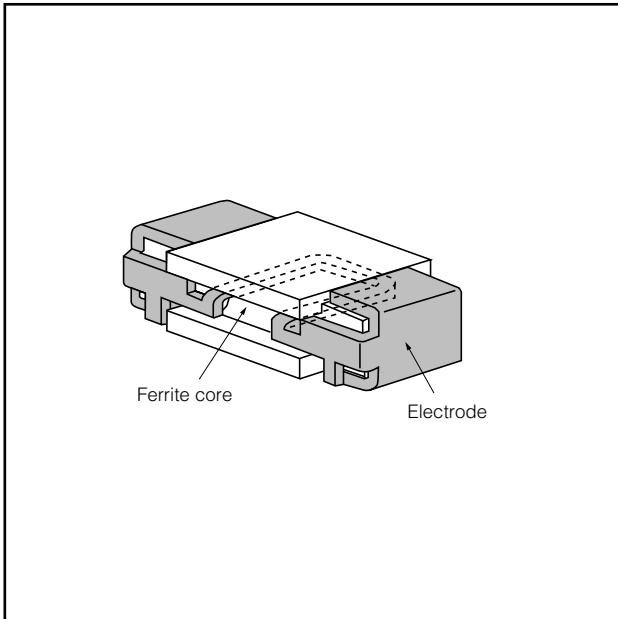

Dimensions in mm (not to scale)

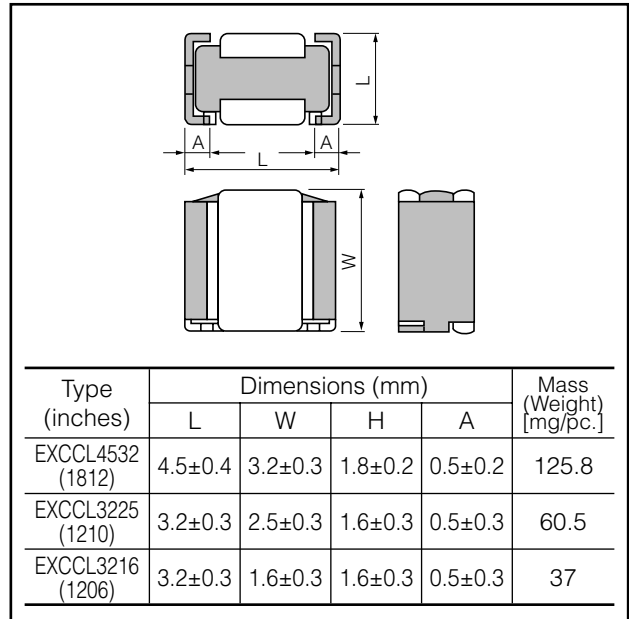

Type: EXCML

Explanation of Part Numbers

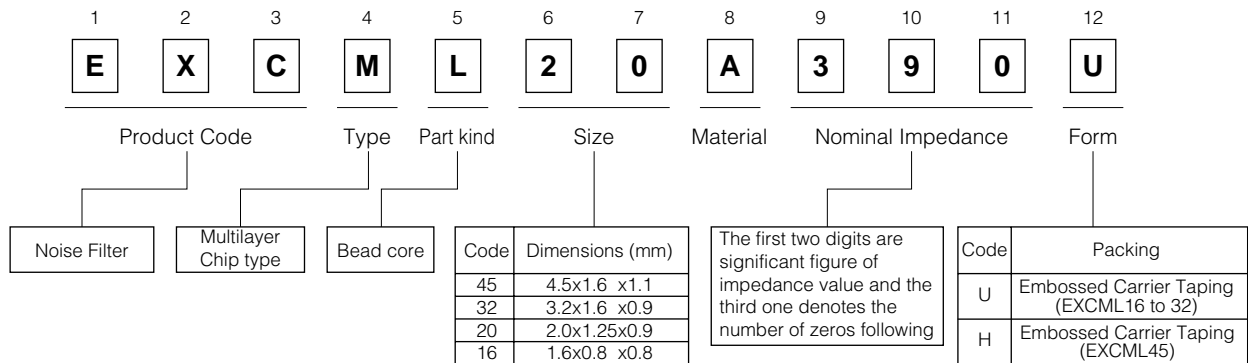

Construction

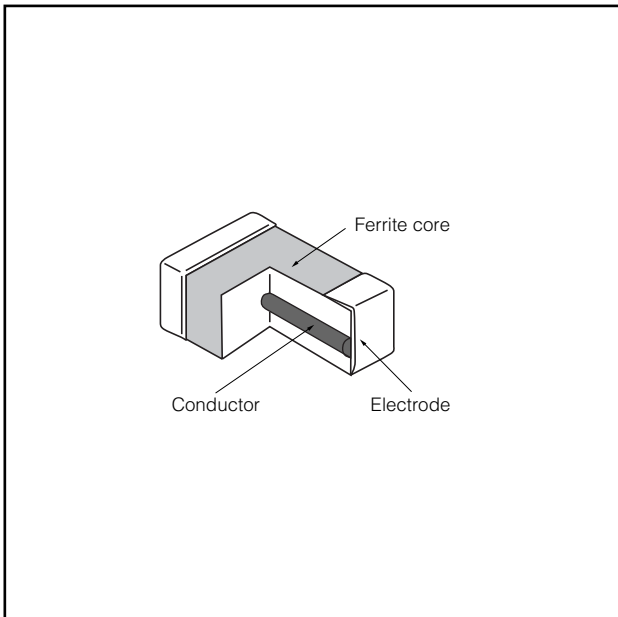

Dimensions in mm (not to scale)

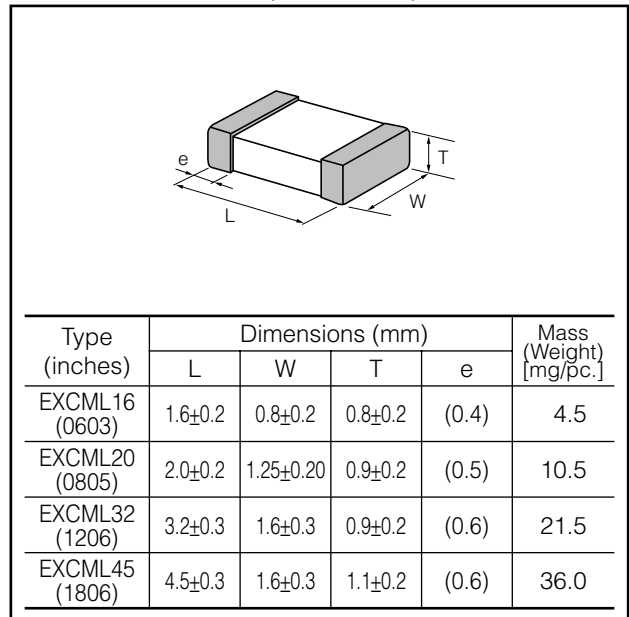

■ Type: EXC3B

● Explanation of Part Numbers

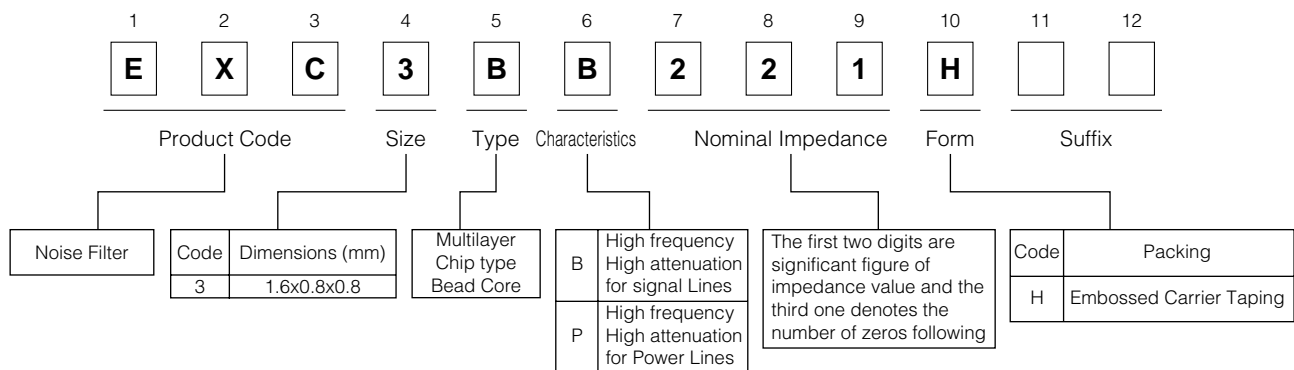

■ Construction

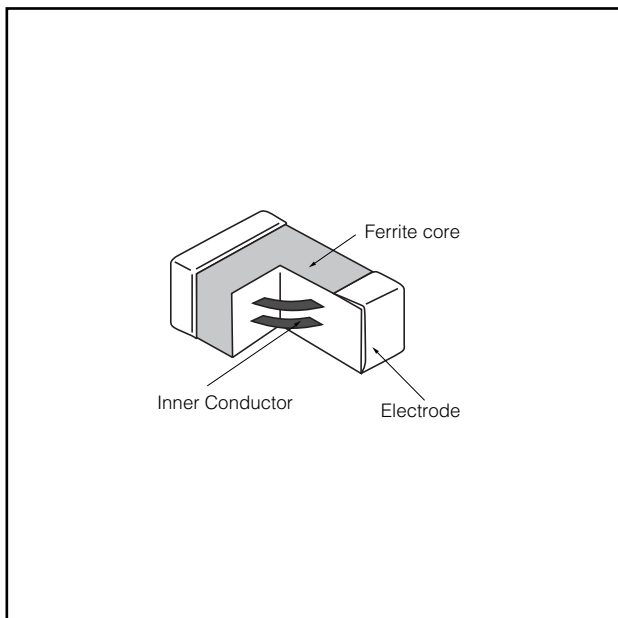

■ Dimensions in mm (not to scale)

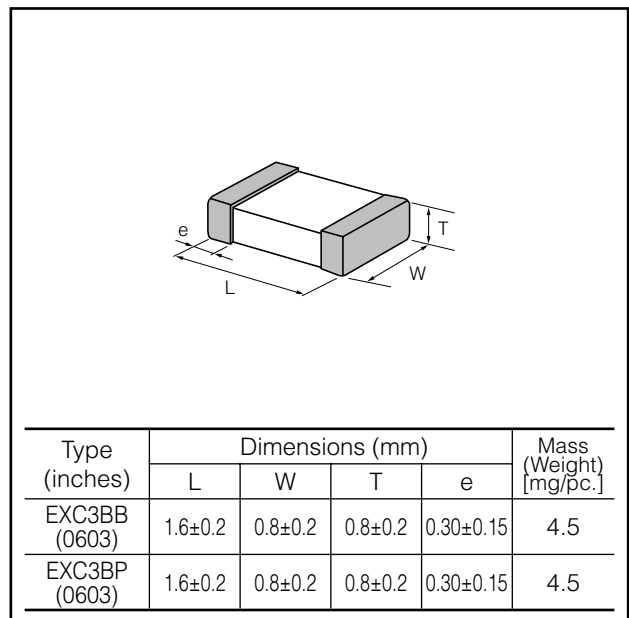

■ Ratings

| Type | Part Number | Impedance | | Rated Current (mA DC) | DC Resistance (Ω) max. |
|------|--------------|----------------|---------|-----------------------|------------------------|
| | | (Ω) at 100 MHz | tol.(%) | | |
| 4532 | EXCCL4532U1 | 115 | ±25 | 2000 | 0.1 |
| 3225 | EXCCL3225U1 | 45 | | 2000 | 0.05 |
| 3216 | EXCCL3216U1 | 25 | | 2000 | 0.05 |
| 4516 | EXCML45A910H | 91 | | 3000 | 0.016 |
| 3216 | EXCML32A680U | 68 | | 3000 | 0.012 |
| 2012 | EXCML20A390U | 39 | | 4000 | 0.008 |
| 1608 | EXCML16A270U | 27 | | 4000 | 0.006 |
| 1608 | EXC3BP600H | 60 | | 1000 | 0.07 |
| | EXC3BP121H | 120 | | 500 | 0.1 |
| | EXC3BB221H | 220 | | 200 | 0.3 |
| | EXC3BB601H | 600 | 100 | 0.8 | |
| | EXC3BB102H | 1000 | 50 | 1 | |

■ Impedance Characteristics (Reference Data)

Measured by HP4291A

|Z| : Impedance

R : Resistance

X : Reactance

●EXCCL4532U1 (4532)

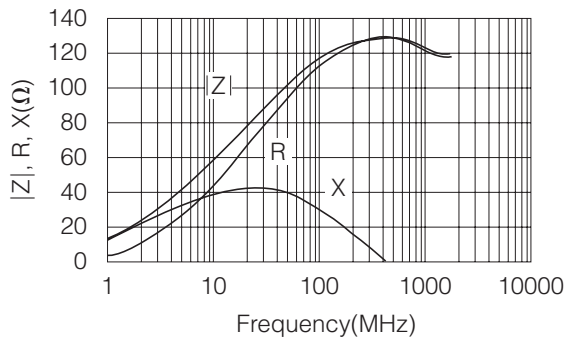

●EXCML16A270U (1608)

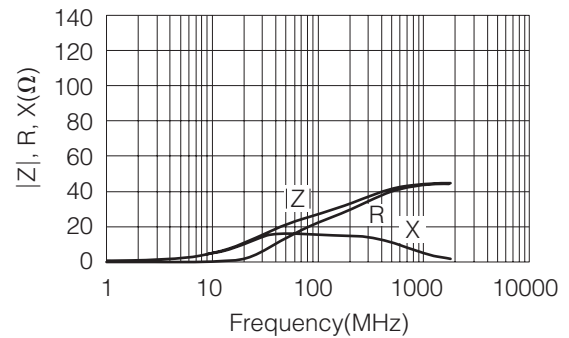

●EXCCL3225U1 (3225)

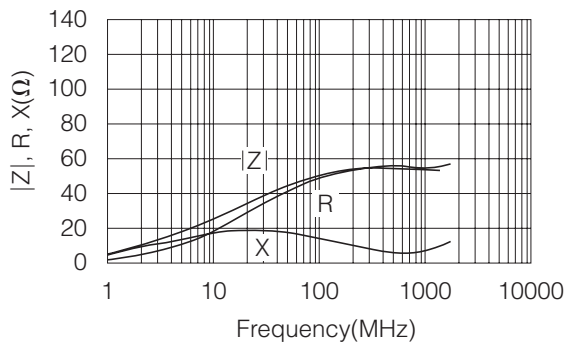

●EXCML20A390U (2012)

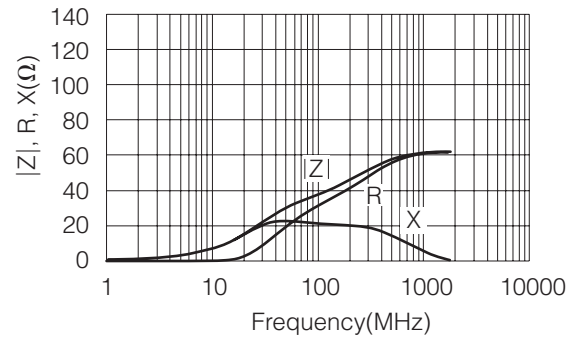

●EXCCL3216U1 (3216)

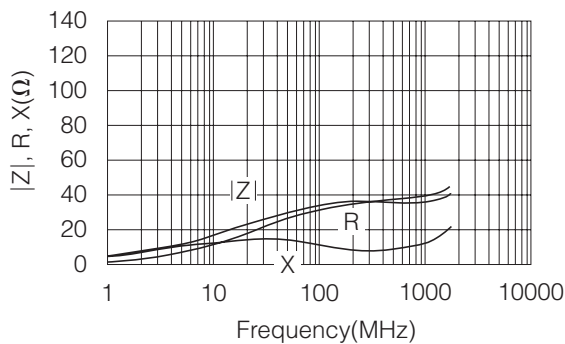

●EXCML32A680U (3216)

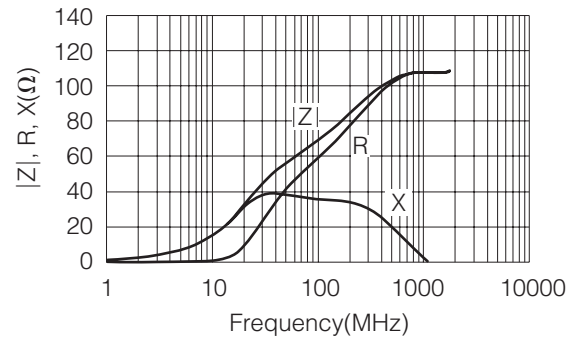

●EXCML45A910H (4516)

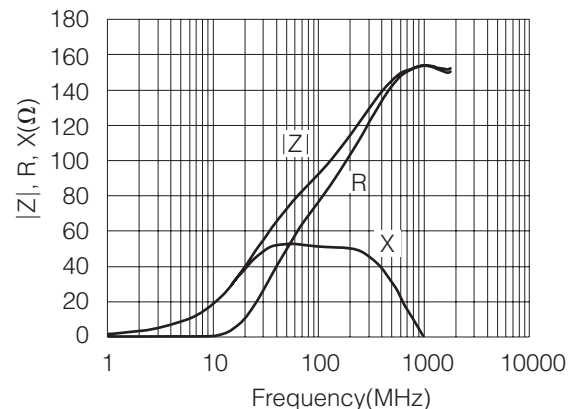

■ Impedance Characteristics (Reference Data)

Measured by HP4291A

|Z| : Impedance

R : Resistance

X : Reactance

●EXC3BB221H (1608)

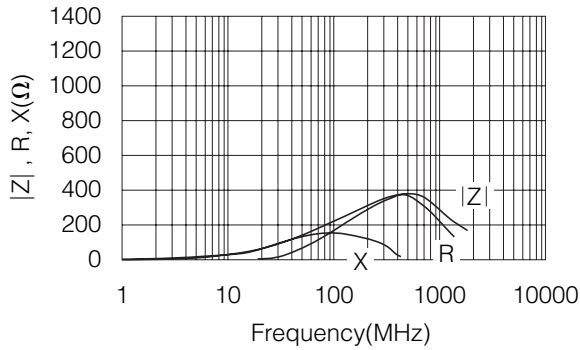

●EXC3BP121H (1608)

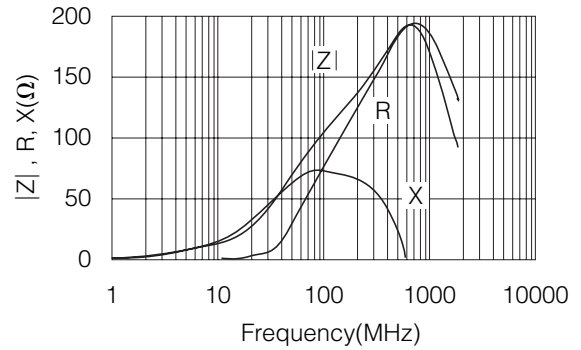

●EXC3BB601H (1608)

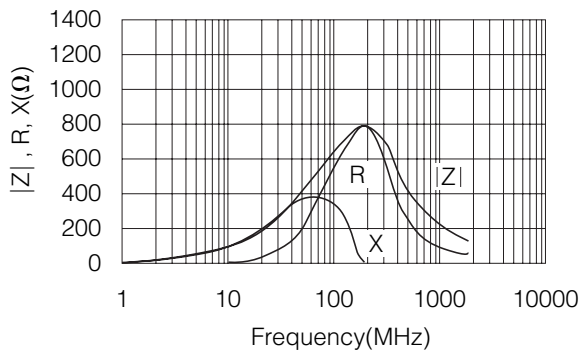

●EXC3BP600H (1608)

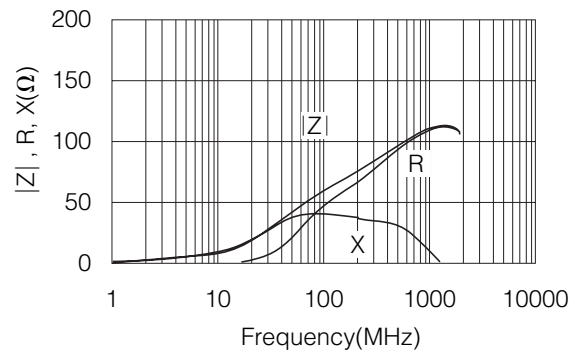

●EXC3BB102H (1608)

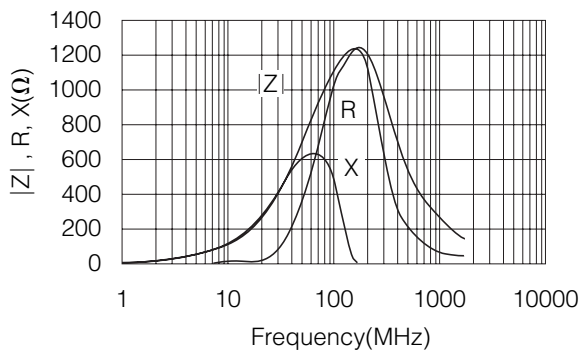

■ Packaging Methods (Taping)

● Standard Quantity

| Part Number | Kind of Taping | Pitch (P ₁) | Quantity |
|--------------|-------------------------|-------------------------|----------------|
| EXCCL4532U1 | Embossed Carrier Taping | 8 mm | 1000 pcs./reel |
| EXCCL3225U1 | | 4 mm | 2000 pcs./reel |
| EXCCL3216U1 | | | 3000 pcs./reel |
| EXCML45A910H | | | 3000 pcs./reel |
| EXCML32A680U | | | 3000 pcs./reel |
| EXCML20A390U | | 4000 pcs./reel | 4000 pcs./reel |
| EXCML16A270U | | | 4000 pcs./reel |
| EXC3B□□□□H | | | 4000 pcs./reel |

● Embossed Carrier Taping

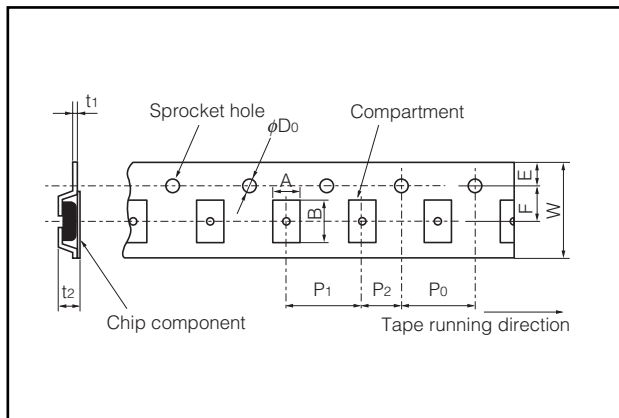

● Taping Reel

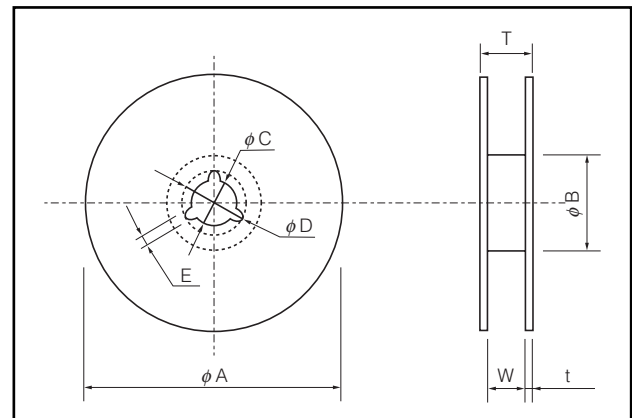

Embossed Carrier Dimensions (mm)

| Part Number | A | B | W | F | E | P ₁ | P ₂ | P ₀ | φD ₀ | t ₁ | t ₂ | | | | |
|--------------|---------|---------|----------|----------|-----------|----------------|----------------|----------------|-----------------|----------------|----------------|---------|---------|-----------|----------|
| EXCCL4532U1 | 3.6±0.2 | 4.9±0.2 | 12.0±0.2 | 5.5±0.1 | 1.75±0.10 | 8.0±0.1 | 2.0±0.1 | 4.0±0.1 | 1.5±0.1 | 0.20±0.05 | 2.4 max. | | | | |
| EXCCL3225U1 | 2.9±0.2 | 3.6±0.2 | 8.0±0.2 | 3.5±0.1 | | 2.1 max. | | | | | | | | | |
| EXCCL3216U1 | 2.0±0.2 | 3.6±0.2 | | 1.8 max. | | | | | | | | | | | |
| EXCML45A910H | 1.9±0.2 | 4.8±0.2 | 12.0±0.2 | 5.5±0.1 | | 4.0±0.1 | | | | | 2.0±0.1 | 4.0±0.1 | 1.5±0.1 | 0.20±0.05 | 1.8 max. |
| EXCML32A680U | 1.9±0.2 | 3.5±0.2 | 8.0±0.2 | 3.5±0.1 | | 1.6 max. | | | | | | | | | |
| EXCML20A390U | 1.5±0.2 | 2.3±0.2 | | | | | | | | | | | | | |
| EXCML16A270U | 1.1±0.2 | 2.1±0.2 | | | | | | | | | | | | | |
| EXC3B□□□□H | 1.0±0.1 | 1.8±0.1 | | | | | | | | | 0.25±0.05 | | | | |

Standard Reel Dimensions (mm)

| Part Number | φA | φB | φC | φD | E | W | T | t |
|--------------|------------------------------------|----------|----------|----------|---------|--------------------------------------|-----------|---------|
| EXCCL4532U1 | 180.0 ⁰ _{-3.0} | 60.0±1.0 | 13.0±0.5 | 21.0±0.8 | 2.0±0.5 | 13.0 ^{+0.5} _{-1.0} | 16.5 max. | 1.2±0.5 |
| EXCCL3225U1 | | | | | | 9.5 ^{+0.5} _{-1.0} | 13 max. | |
| EXCCL3216U1 | | | | | | 13.0 ^{+0.5} _{-1.0} | 16.5 max. | |
| EXCML45A910H | | | | | | 13.0 ^{+0.5} _{-1.0} | 16.5 max. | |
| EXCML32A680U | | | | | | 9.5 ^{+0.5} _{-1.0} | 13 max. | |
| EXCML20A390U | | | | | | | | |
| EXCML16A270U | | | | | | | | |
| EXC3B□□□□H | | | | | | | | |

Design and specifications are each subject to change without notice. Ask factory for the current technical specifications before purchase and/or use. Should a safety concern arise regarding this product, please be sure to contact us immediately.

Recommended Soldering Conditions

Recommendations and precautions are described below.

- Please contact us for additional information when used in conditions other than those specified.
- Please measure the temperature of the terminals and study every kind of solder and printed circuit board for solderability before actual use.

<Recommended reflow soldering temperature>

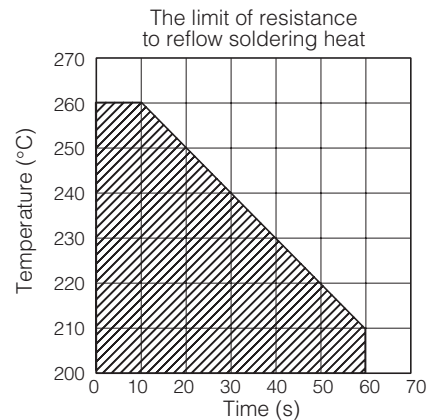
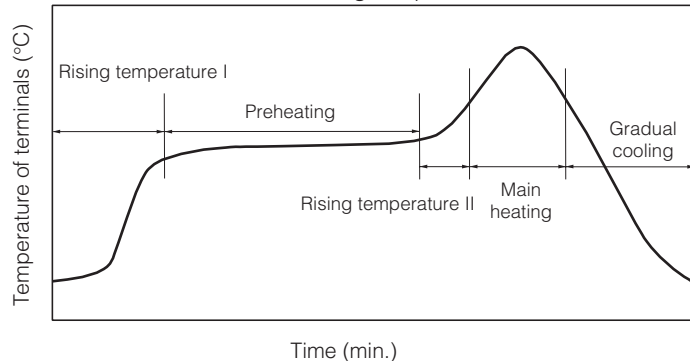

| Solder | Rising temperature I | Preheating | Rising temperature II | Main heating | Gradual cooling |
|--|--|-----------------------------------|--------------------------------------|---|------------------------------------|
| For soldering (Sn-37Pb) | The normal time for preheating 30 s to 60 s | 140 °C to 160 °C 60 s to 120 s | Preheating to 200 °C 20 s to 40 s | 235±10 °C Peak | 200 °C to 100 °C 1 °C to 4 °C/s |
| For lead-free soldering (Sn-3Ag-0.5Cu) | The normal time for preheating 30 s to 60 s | 150 °C to 170 °C 60 s to 120 s | Preheating to 210 °C 20 s to 40 s | 250 ⁺¹⁰ / ₋₅ °C Peak | 210 °C to 100 °C 1 °C to 4 °C/s |

* Reflow soldering shall be performed a maximum of two times.

<Repair with hand soldering>

- Preheat with a blast of hot air or similar method. Use a soldering iron with a tip temperature of 350 °C or less. Solder each electrode for 3 seconds or less.
- Never touch this product with the tip of a soldering iron.

Recommended Land Pattern Dimensions in mm (not to scale)

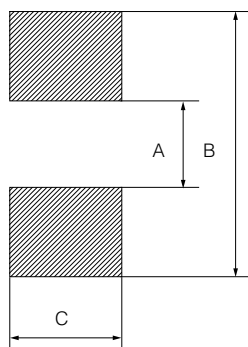

| Part Number | (mm) | | |
|--------------|------------|------------|------------|
| | A | B | C |
| EXCCL4532U1 | 3 | 5.4 | 2.8 |
| EXCCL3225U1 | 1.7 | 4.1 | 2.1 |
| EXCCL3216U1 | 1.7 | 4.1 | 1.2 |
| EXCML45A910H | 2.6 to 3 | 5.5 to 6.5 | 1.2 to 1.6 |
| EXCML32A680U | 1.6 to 2 | 4 to 5 | 1.2 to 1.6 |
| EXCML20A390U | 0.8 to 1.2 | 3 to 4 | 1 to 1.2 |
| EXCML16A270U | 0.6 to 1 | 2 to 3 | 0.8 to 1 |
| EXC3B□□□□H | 0.8 to 1 | 2 to 2.6 | 0.8 to 1 |

⚠ Safety Precautions

The following are precautions for individual products. Please also refer to the precautions common to EMI Filters, Fuses, and Sensors(MR Elements) shown on page EX2 of this catalog.

1. With regard to flow soldering, consult with our sales person in advance.
2. Use rosin-based flux or halogen-free flux.
3. For cleaning, use an alcohol-based cleaning agent. Before using any other type, consult with our sales person in advance.
4. Do not apply shock to Chip Bead Cores (hereafter called the bead cores) or pinch them with a hard tool (e.g. pliers and tweezers). Otherwise, their bodies may be chipped, affecting their performance.
Excessive mechanical stress may damage the bead cores. Handle with care.
5. Store the bead cores in a location with a temperature ranging from -5 °C to +40 °C and a relative humidity of 40 % to 60 %, where there are no rapid changes in temperature or humidity.
6. Use the bead cores within a year (EXC3B Type: within half a year) after the date of the outgoing inspection indicated on the packages.

⚠ Safety Precautions (Common precautions for EMI Filters, Fuses, and Sensors[MR Elements])

- When using our products, no matter what sort of equipment they might be used for, be sure to make a written agreement on the specifications with us in advance. The design and specifications in this catalog are subject to change without prior notice.
- Do not use the products beyond the specifications described in this catalog.
- This catalog explains the quality and performance of the products as individual components. Before use, check and evaluate their operations when installed in your products.
- Install the following systems for a failsafe design to ensure safety if these products are to be used in equipment where a defect in these products may cause the loss of human life or other significant damage, such as damage to vehicles (automobile, train, vessel), traffic lights, medical equipment, aerospace equipment, electric heating appliances, combustion/gas equipment, rotating equipment, and disaster/crime prevention equipment.
- * Systems equipped with a protection circuit and a protection device
- * Systems equipped with a redundant circuit or other system to prevent an unsafe status in the event of a single fault

(1) Precautions for use

- These products are designed and manufactured for general and standard use in general electronic equipment (e.g. AV equipment, home electric appliances, office equipment, information and communication equipment)
- These products are not intended for use in the following special conditions. Before using the products, carefully check the effects on their quality and performance, and determine whether or not they can be used.
 1. In liquid, such as water, oil, chemicals, or organic solvent
 2. In direct sunlight, outdoors, or in dust
 3. In salty air or air with a high concentration of corrosive gas, such as Cl₂, H₂S, NH₃, SO₂, or NO₂
 4. Electric Static Discharge (ESD) Environment
These components are sensitive to static electricity and can be damaged under static shock (ESD). Please take measures to avoid any of these environments.
Smaller components are more sensitive to ESD environment.
 5. Electromagnetic Environment
Avoid any environment where strong electromagnetic waves exist.
 6. In an environment where these products cause dew condensation
 7. Sealing or coating of these products or a printed circuit board on which these products are mounted, with resin or other materials
- These products generate Joule heat when energized. Carefully position these products so that their heat will not affect the other components.
- Carefully position these products so that their temperatures will not exceed the category temperature range due to the effects of neighboring heat-generating components. Do not mount or place heat-generating components or inflammables, such as vinyl-coated wires, near these products (except Thermal Cutoffs).
- Note that non-cleaning solder, halogen-based highly active flux, or water-soluble flux may deteriorate the performance or reliability of the products.
- Carefully select a flux cleaning agent for use after soldering. An unsuitable agent may deteriorate the performance or reliability. In particular, when using water or a water-soluble cleaning agent, be careful not to leave water residues. Otherwise, the insulation performance may be deteriorated.

(2) Precautions for storage

The performance of these products, including the solderability, is guaranteed for a year from the date of arrival at your company, provided that they remain packed as they were when delivered and stored at a temperature of 5 °C to 35 °C and a relative humidity of 45 % to 85 %. (Micro Chip Fuses: Guaranteed for 6 months from the date of arrival at your company)

The performance of EMI Filters is guaranteed for 6 months or a year from the outgoing inspection date indicated on the packages, provided that they are stored at a temperature of -5 °C to +40 °C and a relative humidity of 40 % to 60 %. Check the guarantee period in the specifications. The performance of Thermal Cutoffs is guaranteed for a year from the outgoing inspection date indicated on the packages, provided that they are stored at a temperature of -10 °C to +40 °C and a relative humidity of 30 % to 75 %.

Even within the above guarantee periods, do not store these products in the following conditions. Otherwise, their electrical performance and/or solderability may be deteriorated, and the packaging materials (e.g. taping materials) may be deformed or deteriorated, resulting in mounting failures.

1. In salty air or in air with a high concentration of corrosive gas, such as Cl₂, H₂S, NH₃, SO₂, or NO₂
2. In direct sunlight

<Package markings>

Package markings include the product number, quantity, and country of origin. In principle, the country of origin should be indicated in English.