

DS1630B/DS3630B Hex CMOS Compatible Buffer

General Description

The DS1630B/DS3630B is a high current buffer intended for use with CMOS circuits interfacing with peripherals requiring high drive currents. The DS1630B/DS3630B features low quiescent power consumption (typically $50 \mu\text{W}$) as well as high-speed driving of capacitive loads such as large MOS memories. The design of the DS1630B/DS3630B is such that V_{CC} current spikes commonly found in standard CMOS circuits cannot occur, thereby, reducing the total transient and average power when operating at high frequencies.

Features

- High-speed capacitive driver
- Wide supply voltage range
- Input/output may interface to TTL
- Input/output CMOS compatibility
- No internal transient V_{CC} current spikes
- $50 \mu\text{W}$ typical standby power

Equivalent Schematic and Connection Diagrams

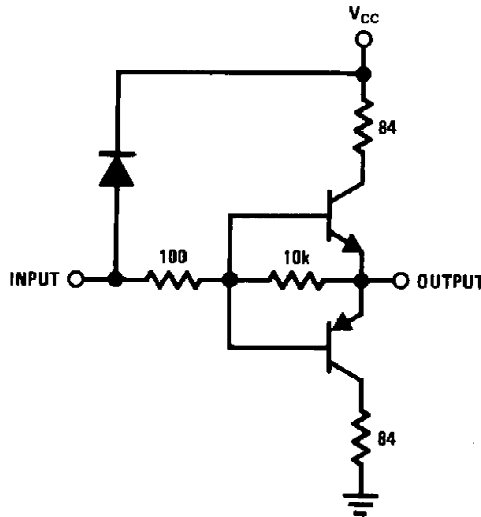

TL/F/5826-1

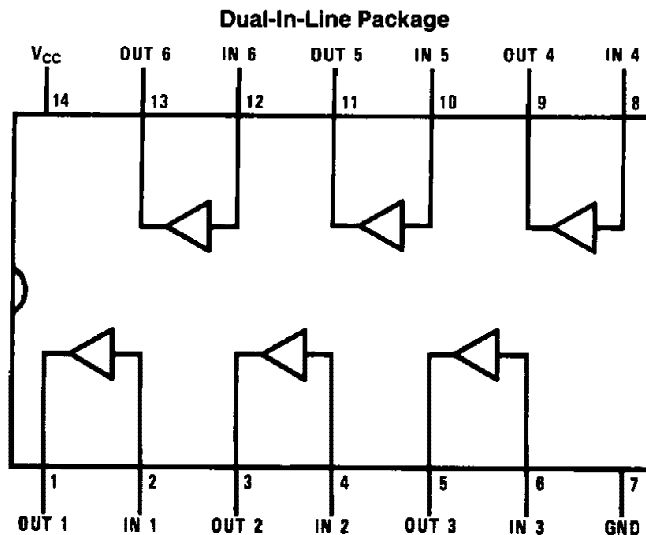

TL/F/5826-2

Top View

Order Number DS1630BJ, DS3630BJ or DS3630BN
 See NS Package Number J14A or N14A

Absolute Maximum Ratings

If Military/Aerospace specified devices are required, please contact the National Semiconductor Sales Office/Distributors for availability and specifications.

Supply Voltage	16V
Input Voltage	16V
Output Voltage	16V
Lead Temperature (Soldering, 4 seconds)	260°C

Operating Conditions

	Min	Max	Units
Supply Voltage (V_{CC})	3	15	V
Temperature (T_A)			
DS1630B	-55	+125	°C
DS3630B	0	+70	°C

Electrical Characteristics (Notes 2 and 3)

Symbol	Parameter	Conditions	Min	Typ	Max	Units	
I_{INH}	Logical "1" Input Current	$V_{IN} = V_{CC}, I_{OUT} = -400 \mu A$	DS1630B		90	200	μA
			DS3630B		90	200	μA
		$V_{IN} = V_{CC} - 2.0V, I_{OUT} = 16 mA$	DS1630B		0.5	6.4	mA
			DS3630B		0.5	4.0	mA
I_{INL}	Logical "0" Input Current	$V_{IN} = 0.4V, I_{OUT} = 16 mA$	DS1630B		-0.15	2.0	mA
			DS3630B		$V_{CC} - 150$	1.3	mA
V_{OH}	Logical "1" Output Voltage	$V_{IN} = V_{CC}, I_{OUT} = -400 \mu A$	DS1630B	$V_{CC} - 1$	$V_{CC} - 0.75$		V
			DS3630B	$V_{CC} - 0.9$	$V_{CC} - 0.75$		V
		$V_{IN} = V_{CC} - 0.4V, I_{OUT} = -16 mA$	DS1630B	$V_{CC} - 2.5$	$V_{CC} - 2.0$		V
			DS3630B	$V_{CC} - 2.5$	$V_{CC} - 2.0$		V
V_{OL}	Logical "0" Output Voltage	$V_{IN} = 0V, I_{OUT} = 400 \mu A$	DS1630B		0.75	1	V
			DS3630B		0.75	0.9	V
		$V_{IN} = 0V, I_{OUT} = 16 mA$	DS1630B		0.95	1.3	V
			DS3630B		0.95	1.3	V
		$V_{IN} = 0.4V, I_{OUT} = 16 mA$	DS1630B		1.2	1.6	V
			DS3630B		1.2	1.5	V

Switching Characteristics $V_{CC} = 5.0V, T_A = 25^\circ C$ unless otherwise specified

Symbol	Parameter	Conditions	Min	Typ	Max	Units
t_{pd0}	Propagation Delay to a Logical "0"	$C_L = 50 pF$		30	45	ns
		$C_L = 250 pF$		40	60	ns
		$C_L = 500 pF$		50	75	ns
t_{pd1}	Propagation Delay to a Logical "1"	$C_L = 50 pF$		15	25	ns
		$C_L = 250 pF$		35	50	ns
		$C_L = 500 pF$		50	75	ns

Note 1: "Absolute Maximum Ratings" are those values beyond which the safety of the device cannot be guaranteed. Except for "Operating Temperature Range" they are not meant to imply that the devices should be operating at these limits. The table of "Electrical Characteristics" provides conditions for actual device operation.

Note 2: Unless otherwise specified min/max limits apply across the $-55^\circ C$ to $+125^\circ C$ temperature range for the DS1630B and across the $0^\circ C$ to $+70^\circ C$ range for the DS3630B. All typicals are given for $V_{CC} = 5.0V$ and $T_A = 25^\circ C$.

Note 3: All currents into device pins shown as positive, out of device pins as negative, all voltages referenced to ground unless otherwise noted. All values shown as max or min on absolute value basis.

Typical Applications

CMOS to Transmission Line Interface

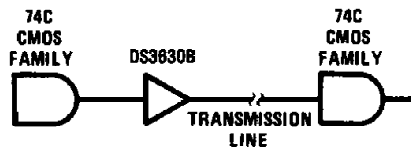

TL/F/5826-3

CMOS to CMOS Interface

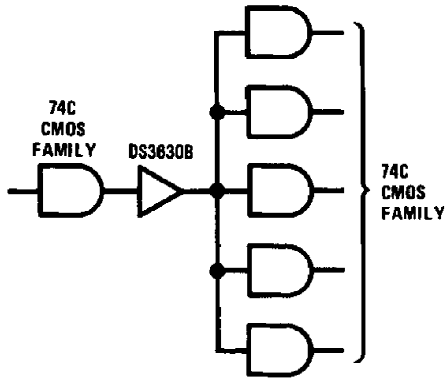

TL/F/5826-4

LED Driver

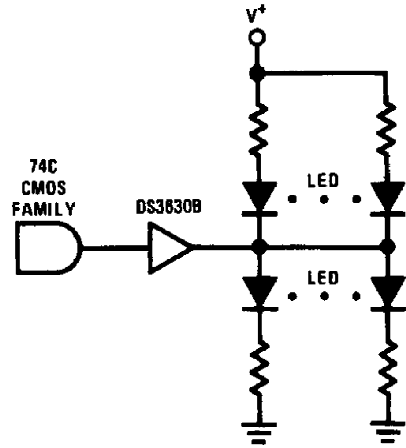

TL/F/5826-5

AC Test Circuit and Switching Time Waveforms

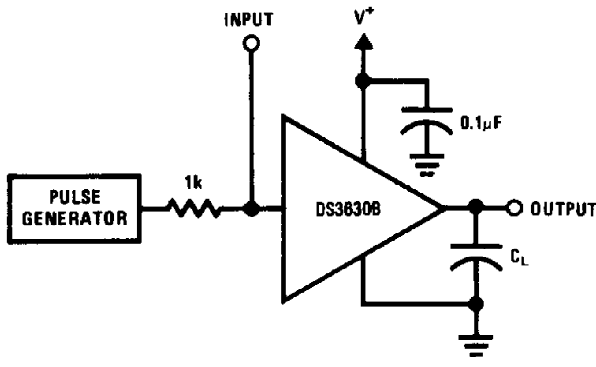

TL/F/5826-7

C_L includes probe and jig capacitance

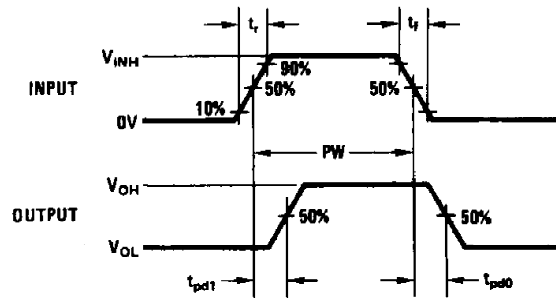

TL/F/5826-8

Pulse Generator characteristics: PRR = 1.0 MHz, PW = 500 ns,
 $t_r = t_f < 10$ ns, $V_{IN} = 0$ to V_{CC}

Typical Performance Characteristics

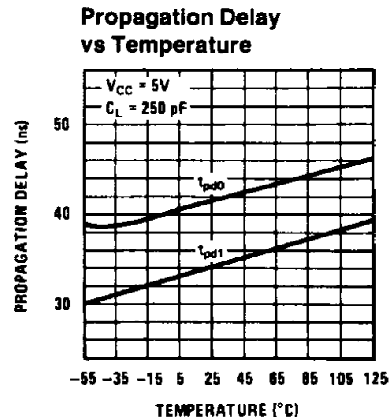
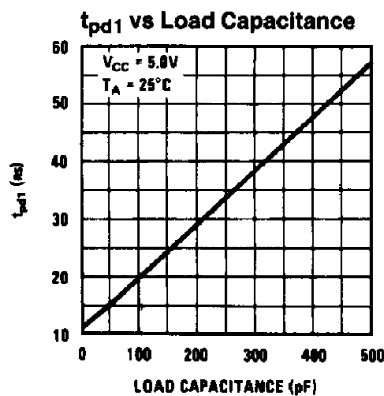
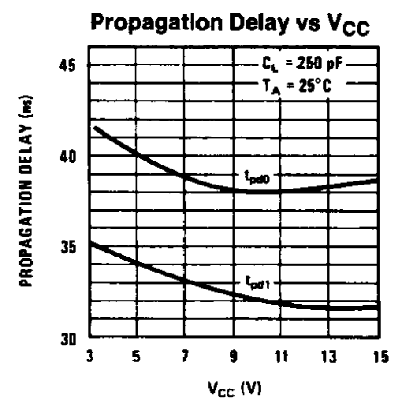
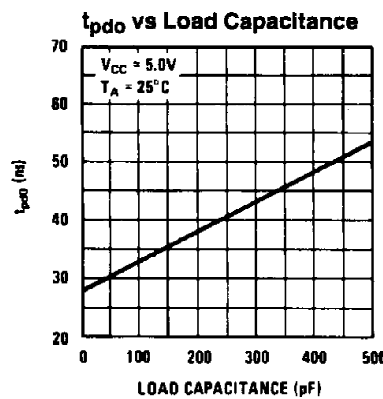
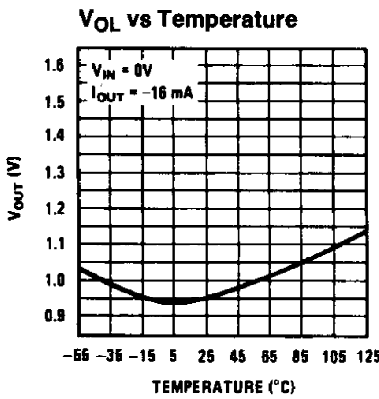
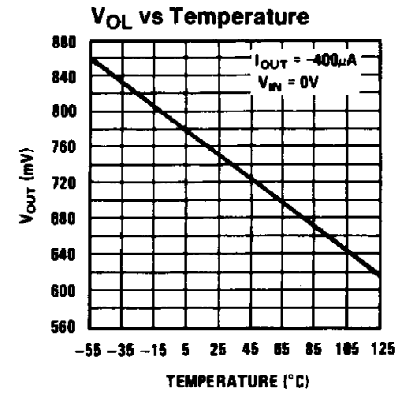
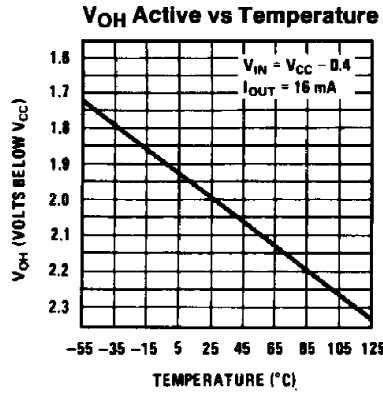
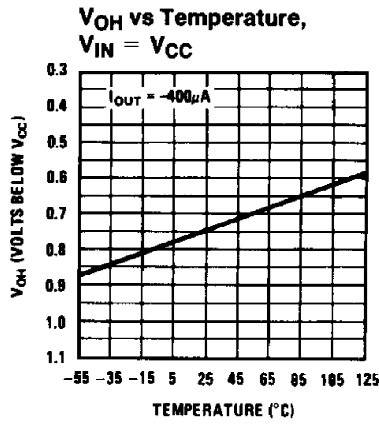

TL/F/5826-6