

Block Diagram

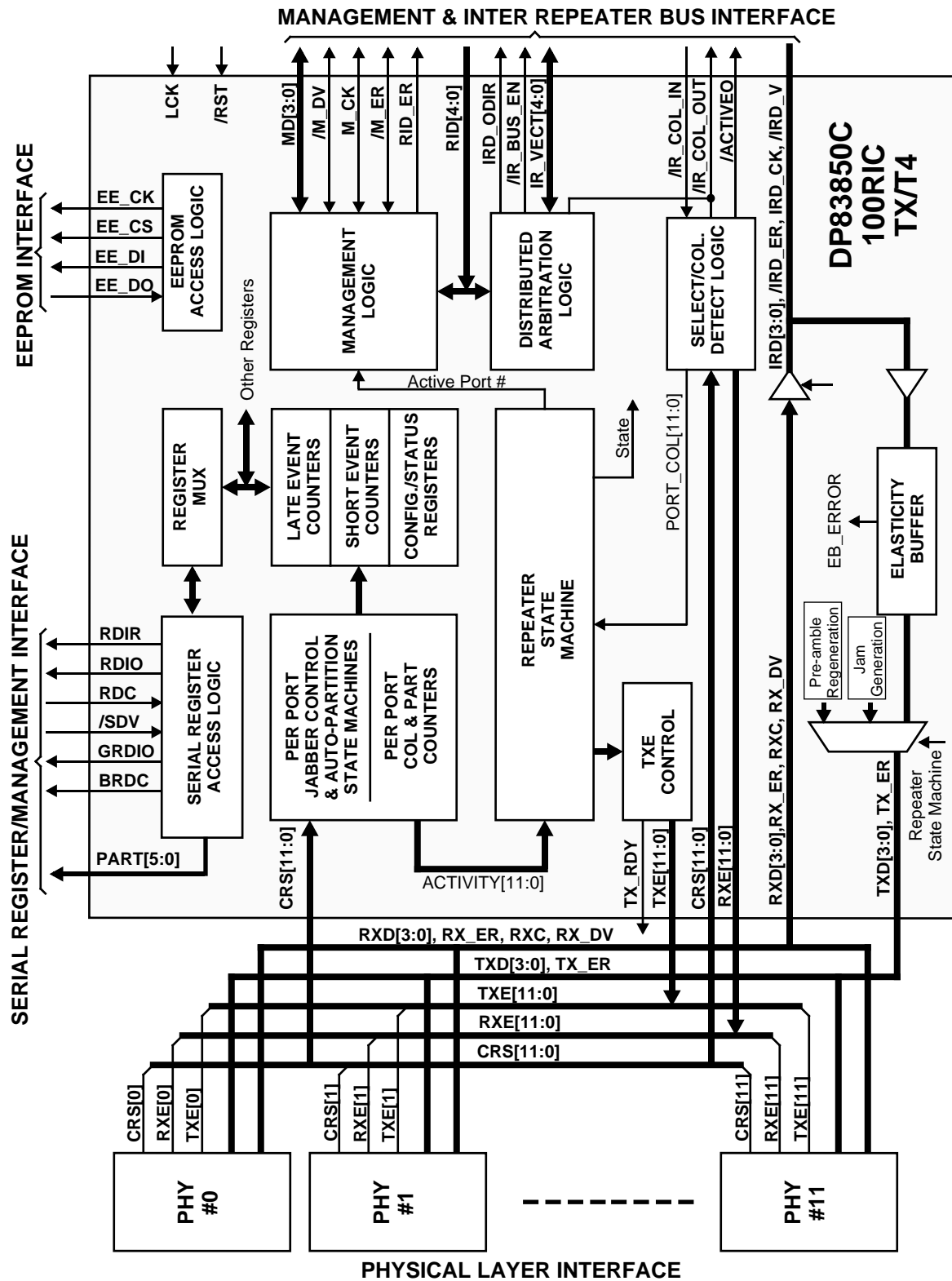
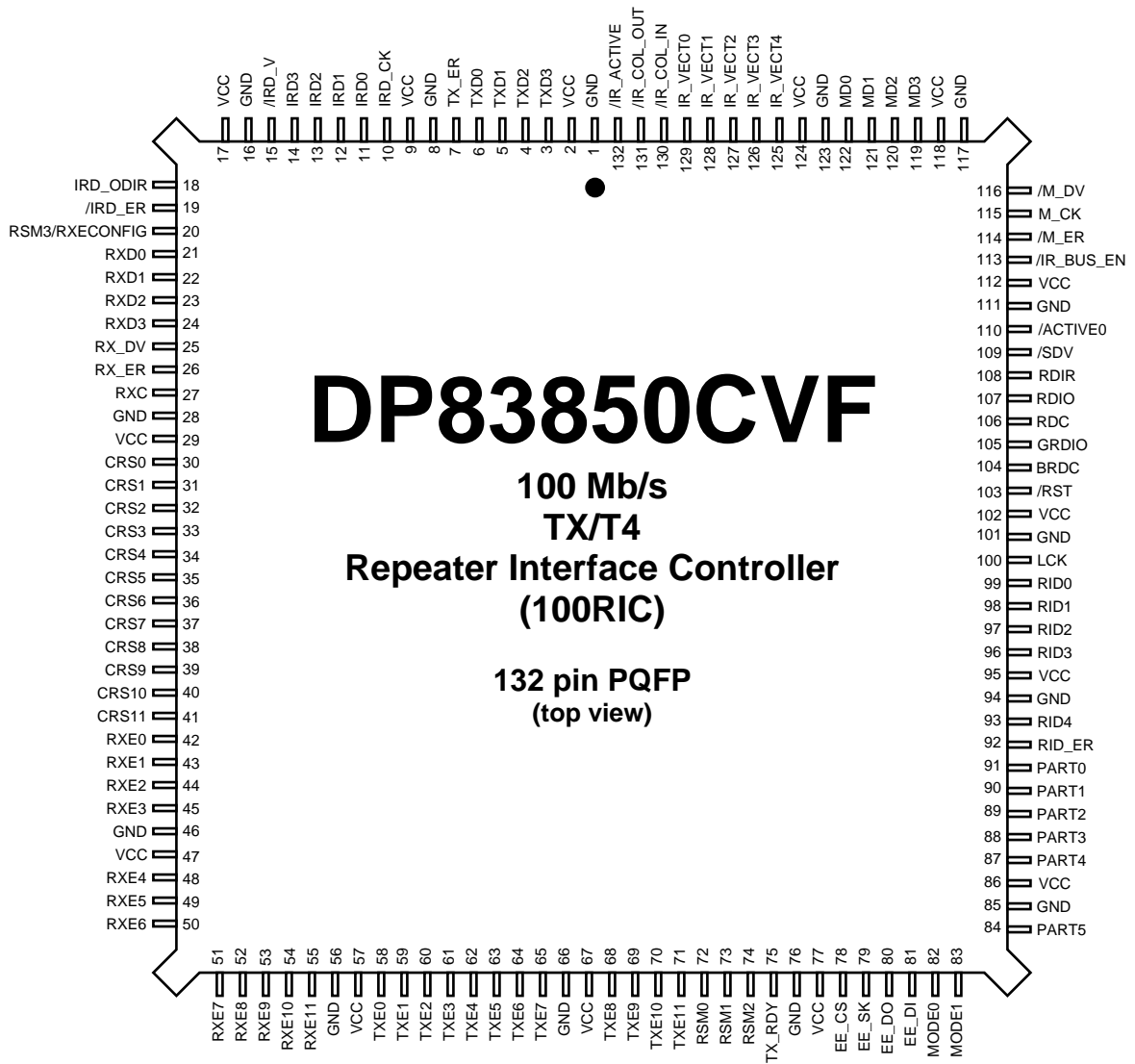

Table of Contents

1.0	Pin Connection Diagram	4	4.0	Registers	16
1.1	Pin Table	5	4.1	Page 0 Register Map	16
2.0	Pin Description	6	4.2	Page 1 Register Map	17
2.1	Physical Layer Interface	6	4.3	Configuration Register (CONFIG)	17
2.2	Inter Repeater and Management Bus Interface	7	4.4	Page Register (PAGE)	18
2.3	EEPROM Interface	8	4.5	Partition Status Register (PARTITION)	18
2.4	Miscellaneous	8	4.6	Jabber Status Register (JABBER)	18
2.5	Pin Type Designation	9	4.7	Administration Register (ADMIN)	19
3.0	Functional Description	10	4.8	Device ID Register (DEVICEID)	19
3.1	Repeater State Machine	10	4.9	Hub ID 0 Register (HUBID0)	19
3.2	RXE Control	10	4.10	Hub ID 1 Register (HUBID1)	20
3.3	TXE Control	10	4.11	Port Management Counter Registers	20
3.4	Data Path	10	4.12	Silicon Revision Register (SIREV)	20
3.5	Elasticity Buffer	10	5.0	DP83850C Applications	21
3.6	Jabber Protection State Machine	11	5.1	MII Interface Connections	21
3.7	Auto-Partition State Machine	11	5.2	Repeater ID Interface	21
3.8	Inter Repeater Bus Interface	11	5.3	Inter Repeater Bus Connections	21
3.9	Management Bus	12	5.4	DP83856 100RIB Connections	25
3.10	Management Event Flags and Counters	12	5.5	Port Partition and Jabber Status LEDs	26
3.11	Serial Register Interface	12	6.0	A.C. and D.C. Specifications	27
3.12	Jabber/Partition LED Driver Logic	15	6.1	D.C. Specifications	27
3.13	EEPROM Serial Read Access	15	6.2	A.C. Specifications	28
			7.0	Physical Dimensions	37

1.0 Pin Connection Diagram



Order Number DP83850CVF
NS Package Number VF132A

1.0 Pin Connection Diagram (Continued)

1.1 Pin Table

Pin Name	Pin No.	Section
/ACTIVE0	110	2.2
/IR_ACTIVE	132	2.2
/IR_BUS_EN	113	2.2
/IR_COL_IN	130	2.2
/IR_COL_OUT	131	2.2
/IRD_ER	19	2.2
/IRD_V	15	2.2
/M_DV	116	2.2
/M_ER	114	2.2
/RST	103	2.4
/SDV	109	2.2
BRDC	104	2.4
CRS[11:0]	41-30	2.1
EE_CK	79	2.3
EE_CS	78	2.3
EE_DI	81	2.3
EE_DO	80	2.3
GND	1, 8, 16, 28, 46, 56, 66,76, 85, 94, 101, 111, 117,123	N/A
GRDIO	105	2.4
IR_VECT[4:0]	125-129	2.2
IRD[3:0]	14-11	2.2
IRD_CK	10	2.2
IRD_ODIR	18	2.4
LCK	100	2.4
M_CK	115	2.2
MD[3:0]	119-122	2.2
MODE[1:0]	83-82	2.4
PART[5:0]	84, 87-91	2.4
RDC	106	2.2
RDIO	107	2.2
RDIR	108	2.4
RID[4:0]	93, 96-99	2.4
RID_ER	92	2.4
RSM[2:0]	74-72	2.4
RSM[3]/ RXECONFIG	20	2.4
RX_DV	25	2.1
RX_ER	26	2.1
RXC	27	2.1
RXD[3:0]	24-21	2.1
RXE[11:0]	55-48, 45-42	2.1
TX_ER	7	2.1
TX_RDY	75	2.1
TXD[3:0]	3-6	2.1
TXE[11:0]	71-68, 65-58	2.1
VCC	2, 9, 17, 29, 47, 57, 67, 77, 86, 95, 102, 112, 118, 124	N/A

2.0 Pin Descriptions

2.1 Physical Layer Interface

Signal Name	Type	Active	Description																					
RXD[3:0]	I	—	Receive Data: Nibble data inputs from each Physical layer chip. Up to 12 ports are supported. Note: Input buffer has a weak pull-up.																					
RXE[11:0]	O, L	high (low)	Receive Enable: Asserted to the respective Physical Layer chip to enable its Receive Data. These pins are either active high or active low depending on the polarity of RSM3 pin as shown below: RXE[11:0] RSM3 Active High Unconnected or pulled high Active Low Pulled down																					
RX_DV	I	high	Receive Data Valid: Asserted High when valid data is present on RXD[3:0]. Note: To ensure that during idle, when 100PHYs TRI-STATE®, this signal is NOT interpreted as “logic one” by the repeater, a 1kΩ pull down resistor must be placed on this pin. The location on this pull down should be between the repeater and the nearest tri-stateable component to the repeater.																					
RX_ER	I	high	Receive Error: The physical Layer asserts this signal high when it detects receive error. When this signal is asserted, the 100PHY (TX or T4) device indicates the type of error on RXD[3:0] as shown below. Note that this data is passed only to the Inter Repeater Bus, and not onto the TX Bus: <table border="1"> <thead> <tr> <th>RX_ER</th> <th>RXD[3:0]</th> <th>Receive Error Condition</th> </tr> </thead> <tbody> <tr> <td>0</td> <td>data</td> <td>Normal data reception</td> </tr> <tr> <td>1</td> <td>0h</td> <td>Symbol code violation</td> </tr> <tr> <td>1</td> <td>1h¹</td> <td>Elasticity Buffer Over/Under-run</td> </tr> <tr> <td>1</td> <td>2h</td> <td>Invalid Frame Termination</td> </tr> <tr> <td>1</td> <td>3h²</td> <td>Reserved</td> </tr> <tr> <td>1</td> <td>4h²</td> <td>10Mb Link Detected</td> </tr> </tbody> </table> ¹ The 100PHY must be configured with the Elasticity Buffer bypassed; hence this error code will never be generated. ² These error codes will only appear when CRS from the 100PHY is not asserted. Since the DP83850C only enables a 100PHY when its CRS is asserted, these error codes will never be passed through the chip. Note: Input buffer has a weak pull-down.	RX_ER	RXD[3:0]	Receive Error Condition	0	data	Normal data reception	1	0h	Symbol code violation	1	1h ¹	Elasticity Buffer Over/Under-run	1	2h	Invalid Frame Termination	1	3h ²	Reserved	1	4h ²	10Mb Link Detected
RX_ER	RXD[3:0]	Receive Error Condition																						
0	data	Normal data reception																						
1	0h	Symbol code violation																						
1	1h ¹	Elasticity Buffer Over/Under-run																						
1	2h	Invalid Frame Termination																						
1	3h ²	Reserved																						
1	4h ²	10Mb Link Detected																						
RXC	I	—	Receive Clock: Recovered clock from the Physical Layer device. RXD, RX_DV, and RX_ER are generated from the falling edge of this clock. Note: Input buffer has a weak pull-down.																					
CRS[11:0]	I	high	Carrier Sense: Asynchronous carrier indication from the Physical Layer device.																					
TXE[11:0]	O, L	high	Transmit Enable: Enables corresponding port for transmitting data.																					
TX_RDY	O, L	high	Transmit Ready: Indicates when a transmit is in progress. Essentially, this signal is the logical 'OR' of all TXEs.																					
TX_ER	O, M	high	Transmit Error: Asserted high when a code violation is requested to be transmitted.																					
TXD[3:0]	O, H	high	Transmit Data: Nibble data output to be transmitted by each Physical Layer device.																					

Note: A table showing pin type designation is given in section 2.5

2.0 Pin Descriptions (Continued)

2.2 Inter Repeater and Management Bus Interface

Signal Name	Type	Active	Description
IRD[3:0]	I/O/Z, M	—	Inter Repeater Data: Nibble data input/output. Transfers data from the “active” DP83850C to all other “inactive” DP83850Cs. The bus master of the IRD bus is determined by IR_VECT bus arbitration. Note: Input buffer has a weak pull-up.
/IRD_ER	I/O/Z, M	low	Inter Repeater Data Error: This signal carries the RX_ER state across the Inter Repeater bus. Used to track receive errors from the physical layer in real-time
/IRD_V	I/O/Z, M	low	Inter Repeater Data Valid: This signal carries the inverted RX_DV state across the Inter Repeater bus. It is used to frame good packets. Note: A recommended 1.5K pull-up prevents first repeated packet corruption .
IRD_CK	I/O/Z, M	—	Inter Repeater Data Clock: All Inter Repeater signals are synchronized to the rising edge of this clock. Note: Input buffer has a weak pull-up.
IRD_ODIR	O, L	high	Inter Repeater Data Outward Direction: This pin indicates the direction of data for an external transceiver. It is HIGH when IRD[3:0], /IRD_V, /IRD_CK, and /IRD_ER are driven out towards the Inter Repeater bus, and LOW when data is being received from the bus.
/IR_ACTIVE	I/O/OC, M	low	Inter Repeater Activity: This “open-collector” type output is asserted when the repeater senses network activity. Note: Input buffer has a weak pull-up.
/IR_COL_IN	I	low	Inter Repeater Collision In: Indication from another DP83850C that it senses two or more ports receiving or another DP83850C has detected a collision. Note: Input buffer has a weak pull-up.
/IR_COL_OUT	O/OC, M	low	Inter Repeater Collision Out: Asserted when the DP83850C senses two or more ports receiving or non-idle, either 1) within this DP83850C or 2) in another DP83850C, using the IR_VECT number to decide (the IR_VECT number read will differ from the number of this DP83850C if another device is active).
IR_VECT[4:0]	I/O/OC, M	high	Inter Repeater Vector: When the repeater senses at least one of its ports active, it drives its unique vector (from RID[4:0]) onto these pins. If the vector value read back differs from its own (because another vector is being asserted by another device), then this DP83850C will: 1) not drive IRD_ODIR signal and, 2) the IRD[3:0], /IRD_ER, /IRD_V, and IRD_CK signals will be placed in TRI-STATE mode. However, if the value read back is the same as its own RID number, this DP83850C will continue to drive the Inter Repeater bus signals. Note that these vectors are driven onto the bus for the duration of /ACTIVEO assertion. Note: Input buffer has a weak pull-up.
MD[3:0]	I/O/Z, M	high	Management Data: Outputs management information for the DP83856 management chip. During packet reception the DP83850C drives its RID number and the port number of the receiving port onto this bus. Note: Input buffer has a weak pull-up.
/M_DV	I/O/Z, M	low	Management Data Valid: Asserted when valid data is present on MD[3:0]. Note: Input buffer has a weak pull-up.
M_CK	I/O/Z, M	—	Management Clock: All data transfers on the management bus are synchronize to the rising edge of this clock. Note: Input buffer has a weak pull-up.
/M_ER	I/O/Z, M	low	Management Error: Asserted when an Elasticity Buffer overrun or under-run error has been detected. Note: Input buffer has a weak pull-up.

2.0 Pin Descriptions (Continued)

Signal Name	Type	Active	Description
/IR_BUS_EN	O,L	low	Inter-Repeater Bus Enable: This signal is asserted at all times (either when the 100RIC is driving the bus or receiving from the bus) and it is deasserted only when the 100RIC switches direction from an input (receiving) mode to an output (driving) mode. After this switch, this signal becomes asserted again.
RDIO	I/O/Z, L	—	Register Data I/O: Serial data input/output transfers data to/from the internal registers. Serial protocol conforms to the IEEE 802.3u MII (Media Independent Interface) specification. Note: Input buffer has a weak pull-up.
RDC	I	—	Register Data Clock: All data transfers on RDIO are synchronized to the rising edge of this clock. RDC is limited to a maximum frequency of 2.5 MHz. At least 3 cycles of RDC must be provided during assertion of /RST (pin 103) to ensure proper reset of all internal blocks.
/SDV	I	low	Serial Data Valid: Asserted when a valid read or write command is present. Used to detect disconnection of the management bus so that synchronization is not lost. If not used, tie this pin to GND. Note: Input buffer has a weak pull-up.
/ACTIVEO	O/OC, M	low	Active Out: Enable for the IR_VECT[4:0] and /IR_ACTIVE signals. Used in multi-DP83850C systems to enable the external buffers driving these Inter Repeater Bus signals. A pull up of 680 1/2 must be used with this signal.

Note: A table showing pin type designation is given in section 2.5

2.3 EEPROM Interface

Signal Name	Type	Active	Pin Description
EE_CS	O, L	high	EEPROM Chip Select: Asserted during reads to EEPROM.
EE_CK	O, L	-	EEPROM Serial Clock: Local Clock ÷ 32 = 0.78125MHz
EE_DO	I	-	EEPROM Serial Data Out: Connected to the serial data out of the EEPROM.
EE_DI	O, L	-	EEPROM Serial Data In: Connected to the serial data in of the EEPROM.

2.4 Miscellaneous

Signal Name	Type	Active	Pin Description
LCK	I	—	Local Clock: Must be 25 MHz ± 50ppm. Used for TX data transfer to Physical Layer devices, TX Bus data transfers and DP83850C internal state machines.
RID[4:0]	I	—	Repeater Identification Number: Provides the unique vector for the IR_VECT[4:0] signals used in Inter Repeater bus arbitration. These bit are also used to uniquely identify this chip for serial register accesses. The RID value is latched when reset is deasserted. Note: The arbiter cannot use the value 1Fh as its arbitration vector. This is the IR_VECT[4:0] bus idle state, therefore RID[4:0] must never be set to this value.
/RST	I	low	Reset: The chip is reset when this signal is asserted low.
GRDIO	I/O/Z, L	—	Gated Register Data Input/Output: This I/O is a gated version of RDIO. When the “phy_access” bit in the CONFIG register is set high, the RDIO signal is passed through to GRDIO for accessing the physical layer chips. Note: Input buffer has a weak pull-up.
BRDC	O, L	—	Buffered Register Data Clock: Buffered version of RDC. Allows more devices to be chained on the MII serial bus.
RDIR	O, L	high	Register Data Direction: Direction signal for an external bi-directional buffer on the RDIO signal. 0 = RDIO data flows into the DP83850C 1 = RDIO data flows out of the DP83850C Defaults to 0 when no register access is present.

2.0 Pin Descriptions (Continued)

Signal Name	Type	Active	Pin Description										
PART[5:0]	O, L	—	Partition: Used to indicate each port's Jabber and Partition status. PART[3:0] cycle through each port number (0-11) continuously. PART[4] indicates the Partition status for each port (1 = Port Partitioned). PART[5] indicates the Jabber status for each port (1 = Port Jabbering). These pins are intended to be decoded to drive LEDs.										
RID_ER	O, L	high	Repeater ID Error: This pin is asserted under the conditions which set the RID_error bit in the DEVICEID register.										
RSM[3] /RXECONFIG	I/O, L	—	Repeater State Machine Output/ RXE Polarity: This pin is an input during reset and it is used to latch the desired polarity of RXE[11:0] signals. When this pin is pulled high or it is unconnected, then the RXE signals become active high. However, if this signal is pulled low, then the RXE signals become active low. In all other non-reset times, this pin reflects the output of the Repeater State Machine.										
RSM[3] RSM[2:0]	I/O, L O, L	—	Test Outputs indicating the state of the Repeater State Machine. RSM[3:0] State <table style="margin-left: 20px;"> <tr><td>0</td><td>idle</td></tr> <tr><td>1</td><td>collision</td></tr> <tr><td>2</td><td>one port left</td></tr> <tr><td>3</td><td>repeat</td></tr> <tr><td>4</td><td>noise</td></tr> </table> Other states are undefined.	0	idle	1	collision	2	one port left	3	repeat	4	noise
0	idle												
1	collision												
2	one port left												
3	repeat												
4	noise												
MODE[1:0]	I	—	Mode Inputs: The 100RIC may be configured in the following modes: MODE[1:0] Operation <table style="margin-left: 20px;"> <tr><td>0,0</td><td>No special modes selected</td></tr> <tr><td>1,0</td><td>Test mode</td></tr> <tr><td>0,1</td><td>Test mode</td></tr> <tr><td>1,1</td><td>Preamble regeneration (T4) mode</td></tr> </table>	0,0	No special modes selected	1,0	Test mode	0,1	Test mode	1,1	Preamble regeneration (T4) mode		
0,0	No special modes selected												
1,0	Test mode												
0,1	Test mode												
1,1	Preamble regeneration (T4) mode												

Note: A table showing pin type designation is given in section 2.5

2.5 Pin Type Designation

Pin Type	Description
I	Input Buffer
O	Output Buffer, driven high or low at all times
I/O/Z	Bi-directional Buffer with high impedance output
O/Z	Output Buffer with high impedance capability
OC	Open Collector like signals. These buffers are either driven low or in a high-impedance state.
L	Output low drive: 4 mA
M	Output medium drive: 12 mA
H	Output high drive : 24 mA

3.0 Functional Description

The following sections describe the different functional blocks of the DP83850C 100 Mb/s Repeater Interface Controller. The IEEE 802.3u repeater specification details a number of functions a repeater system is required to perform. These functions are split between those tasks that are common to all data channels and those that are specific to each individual channel. The DP83850C follows this split task approach for implementing the required functions. Where necessary, the difference between the TX and T4 modes is discussed.

3.1 Repeater State Machine

The Repeater State Machine (RSM) is the main block that governs the overall operation of the repeater. At any one time, the RSM is in one of the following states: Idle, Repeat, Collision, One Port Left, or Noise.

3.1.1 Idle State

The RSM enters this state after reset or when there is no activity on the network and the carrier sense is not present. The RSM exits from this state if the above conditions are no longer true.

3.1.2 Repeat State

This state is entered when there is a reception on only one of the ports, port N. While in this state, the data is transmitted to all the ports except the receiving port (port N). The RSM either returns to Idle state when the reception ends, or transitions to Collision state if there is reception activity on more than one port.

3.1.3 Collision State

When there is receive activity on more than one port of the repeater, the RSM moves to Collision state. In this state, transmit data is replaced by Jam and sent out to all ports including the original port N.

There are two ways for the repeater to leave the Collision state. The first is when there is no receive activity on any of the ports. In this case, the repeater moves to Idle state. The second is when there is only one port experiencing collision in which case the repeater enters the One Port Left state.

3.1.4 One Port Left State

This state is entered only from the Collision state. It guarantees that repeaters connected hierarchically will not jam each other indefinitely. While in this state, Jam is sent out to all ports except the port that has the receive activity. If more receive activity occurs on any other port, then the repeater moves to Collision state.

Otherwise, the repeater will transition to Idle state when the receive activity ends.

3.1.5 Noise State

When there is an Elasticity Buffer overflow or underflow during packet reception, then the repeater enters the Noise state. During this state, the Jam pattern is sent to all transmitting ports. The repeater leaves this state by moving either to the Idle state, if there is no receive activity on any ports, or to the Collision state, if there is a collision on one of its segments.

3.2 RXE Control

When only one port has receive activity, the RXE signal (receive enable) is activated. If multiple ports are active (i.e. a collision scenario), then RXE will not be enabled for

any port. The Port Select Logic asserts the open-collector outputs /IR_COL_OUT and /IR_ACTIVE to indicate to other cascaded DP83850Cs that there is collision or receive activity present on this DP83850C.

The polarity of the RXE signal can be set through an external pull down resistor placed at the RSM[3] pin. That is, if the RSM[3] pin is unconnected or pulled high, then the RXE is active high and when the RSM[3] is pulled low, then the RXE is active low.

3.3 TXE Control

This control logic enables the appropriate ports for data transmission according to the four states of the RSM. For example, during Idle state, no ports are enabled; during Repeat state, all ports but port N are enabled; in Collision state, all ports including port N are enabled; during One Port Left state, all ports except the port experiencing the collision will be enabled.

3.4 Data Path

After the Port Selection logic has enabled the active port, receive data (RXD), receive clock (RXC), receive error (RX_ER) and receive data valid (RX_DV) will flow through the chip from that port out onto the Inter Repeater (IR) bus if no collisions are present. The signals on the IR bus flow either in to or out of the chip depending upon the Repeater's state.

If the DP83850C is currently receiving and no collisions are present, the IR signals flow out of the chip. The DP83850C's Arbitration Logic guarantees that only one DP83850C will gain ownership of the IR bus. In all other states, the IR signals are inputs.

When IR signals are inputs, the signals flow into the Elasticity Buffer (EB). Here, the data is re-timed and then sent out to the transmit ports. The Transmit Control logic determines which ports are enabled for data transmission.

If a collision occurs, a Jam pattern is sent out from the EB instead of the data. The Jam pattern (3,4,3,4,..... from the DP83850C, encoded by the Physical Layer device as 1,0,1,0,.....) is transmitted for the duration of the collision activity.

If the repeater is configured in the preamble regeneration mode (T4 mode), approximately 12 clock cycles after the assertion of /IR_ACTIVE (indicating a packet reception on a segment), the 100RIC begins to transmit the preamble pattern onto the other network segments. While the preamble is being transmitted, the EB monitors the received clock and data signals. When the start of the frame delimiter "SFD" is detected, the received data stream is written into the EB. After this point, data from the EB is sent out to the Transmit interface. The preamble is always generated in its entirety (i.e. fifteen 5's and one D) even if a collision occurs.

3.5 Elasticity Buffer

The elasticity buffer, or a logical FIFO buffer, is used to compensate for the variations and timing differences between the recovered Receive Clock and the local clock. This buffer supports maximum clock skews of 200ppm for the preamble regeneration (T4) mode, and 100ppm for the TX mode, within a maximum packet size of 1518 bytes.

3.0 Functional Description (Continued)

3.6 Jabber Protection State Machine

The jabber specification for 100BASE-T is functionally different than 10BASE-T.

In 10BASE-T, each port's Jabber Protect State machine ensures that Jabber transmissions are stopped after 5ms and followed by 96 to 116 bit times silence before the port is re-enabled.

In 100BASE-T, when a port jabbars, its receive and transmit ports are cutoff until the jabber activity ceases. All other ports remain unaffected and continue normal operation. The 100BASE-T Jabber Protect Limit (that is, the time for which a port can jabber until it is cutoff) for the DP83850C is reached if the CRS is active for more than 655 μ s.

A jabbering port that is cut off will be re-enabled when the jabber activity ceases and the IDLE line condition is sensed.

3.7 Auto-Partition State Machine

In order to protect the network from a port that is experiencing excessive consecutive collisions, each port must have its own auto-partition state machine.

A port with excessive consecutive collisions will be partitioned after a programmed number of consecutive collisions occur on that port. Transmitting ports will not be affected.

The DP83850C has a configuration bit that allows the user to choose how many consecutive collisions a port should experience before partitioning. This bit can be set for either 32 or 64 consecutive collisions. The IEEE802.3u 100BASE-T standard specifies the consecutive collisions limit as greater than 60. A partitioned port will be reconnected when a collision-free packet of length 512 bits or more (that is, at least a minimum sized packet) is transmitted out of that port.

The DP83850C also provides a configuration bit that disables the auto-partition function completely.

3.8 Inter Repeater Bus Interface

The Inter Repeater bus is used to connect multiple DP83850Cs together to form a logical repeater unit and also to allow a managed entity. The IR bus allows received data packets to be transferred from the receiving DP83850C to the other DP83850Cs in the system. These DP83850Cs then send the data stream to their transmit enabled ports.

Notification of collisions to other cascaded DP83850Cs is as important as data transfer across the network. The arbitration logic asynchronously determines if more than one 100RIC, cascaded together, are receiving simultaneously. The IR bus has a set of status lines capable of conveying collision information between DP83850Cs to ensure their main state machines operate in the appropriate manner.

The IR bus consists of the following signals:

- Inter Repeater Data. This is the transfer data, in nibble format, from the active DP83850C to all other cascaded DP83850Cs.
- Inter Repeater Data Error. This signal carries the receive error status from the physical layer in real-time.
- Inter Repeater Data Valid. This signal is used to frame good packets.
- Inter Repeater Data Clock. All IR data is synchronized to this clock.

- Inter Repeater Data Outward Direction. This pin indicates the direction of the data flow with respect to the DP83850C. When the DP83850C is driving the IR bus (i.e. it contains port N) this signal is HIGH and when the DP83850C is receiving data from other DP83850Cs over the IR bus this signal is LOW.
- Inter Repeater Bus Enable. This signal (connected to the /ENABLE pin of the external transceivers on the IR bus) is used in conjunction with the IRD_ODIR signal (connected to the DIR pin of the transceivers) to TRI-STATE these transceivers during the change of direction from input to output, or vice versa. This signal is always active allowing the IR bus signals to pass through the transceivers into or out of the 100RIC. However when the 100RIC switches from input mode (IRD_ODIR=0) to output mode (IRD_ODIR=1), the /IR_BUS_EN signal is deasserted allowing the transceivers to TRI-STATE during the direction change. After this turn-around, this signal is asserted back again. (IRD_ODIR assertion (high) to /IR_BUS_EN low timing is a minimum of 0.1 ns. and a maximum of 1.0. The time from /IR_BUS_EN (high) to the IRD_ODIR high is a minimum of 10 ns. and a maximum of 20 ns. In addition, /ACTIVEO assertion (low) to /IR_BUS_EN high timing is a maximum of 1.0 ns.)
- Inter Repeater Activity. When there is network activity the DP83850C asserts this output signal.
- Inter Repeater Collision Output. If there are multiple receptions on ports of a DP83850C or if the DP83850C senses concurrent activity on another DP83850C it asserts this output.
- Inter Repeater Collision Input. This input indicates that one of the cascaded DP83850Cs is experiencing a collision.
- Inter Repeater Vector. When there is reception on a port the DP83850C drives a unique vector onto these lines. The vector on the IR bus is compared with the Repeater ID (RID). The DP83850C will continue to drive the IR bus if both the vector and RID match.

The following figure shows the conditions that cause an open collector vector signal to be asserted on the backplane bus.

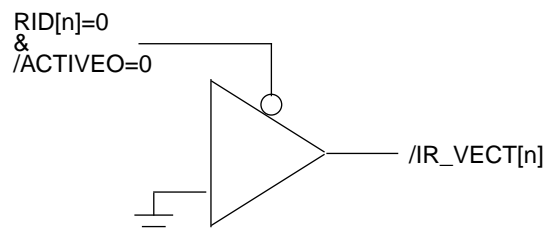

Figure 1. Open Collector /IR_VECT[n]

As seen, if the RID[n]=1, and the repeater is receiving on a port, then the /IR_VECT[n] value would be 1 due to the pull-up on this pin. In the case that RID[n]=0, then a zero is driven out on the /IR_VECT[n] signal.

As an example assume that two repeaters with RIDs equal to RID #1=00010 and RID #2=00011 are connected through the Inter-RIC bus. The following diagrams depict the values of /IR_VECT signals over the backplane.

- Active Output. This signal is asserted by a DP83850C when at least one of its ports is active. It is used to enable external bus transceivers.

3.0 Functional Description (Continued)

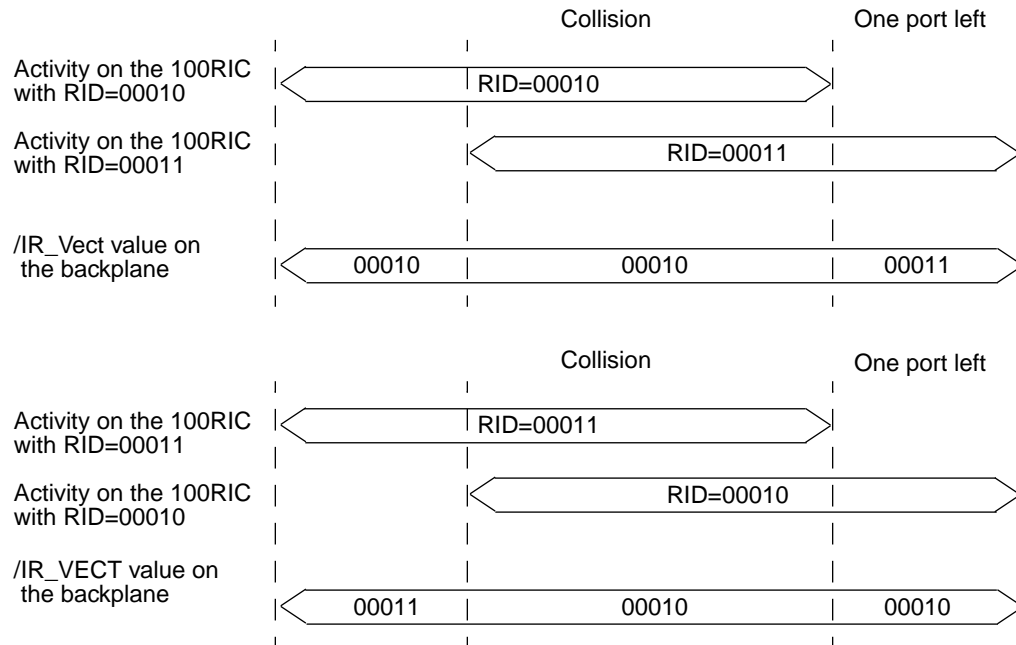

Figure 2. RID to /IR_VECT Mapping

3.9 Management Bus

The task of network statistics gathering in a repeater system is divided between the DP83850C and DP83856 devices. Together, these devices collect all the required management information (compliant to IEEE 802.3u clause 30) associated with a packet.

Each time a packet is received by a DP83850C, it drives the device and the port number onto the management bus in 3 contiguous nibbles of data.

During a single reception, only one DP83850C drives this information onto the management bus. During a collision, the management bus will TRI-STATE (because the information on this bus becomes invalid).

The first nibble of management data contains the least significant 4 bits of the RID number, the second contains the most significant bit of the RID number and the third contains the number of the receiving port.

When the 100RIC is not receiving a packet, it monitors the RID numbers from other 100RICs. If there is a match between any of these numbers and 100RIC's own RID, then a RID contention error signal (RID_ER) is asserted.

The management bus also indicates whether an elasticity buffer error (due to under-run or over-run) has occurred by asserting the /M_ER signal.

3.10 Management Event Flags and Counters

Repeater management statistics are supported either directly by using the DP83850C's on-chip event flags and counters, or indirectly, by the DP83850C providing the information to the DP83856 via the management and transmit bus.

Management information is maintained within the DP83850C in two ways: event flags and counters.

3.10.1 Event Flags

These are the events that provide a snapshot of the operation of the DP83850C. These events include:

- Auto-Partition State, indicating whether a port is currently partitioned.
- Jabber State, indicating whether a port is in jabber state.
- Administration State, indicating if a port is disabled.

3.10.2 Event Counters

The event counters maintain the statistics for events that occur too frequently for polled flags, or are collision oriented. Each port has its own set of event counters that keep track of the following events:

- Port Collisions. A 32-bit counter providing the number of collision occurrences on a port.
- Port Partitions. A 16-bit counter indicating the number of times that the port has partitioned.
- Late Events. A 32-bit counter indicating the number of times that a collision took place after 512 bit times (nominal). In the case of late events, both the late event and the collision counters will be incremented.
- Short Events. A 32-bits wide counter indicating the number of packets whose length is 76 bits (nominal) or less.

3.11 Serial Register Interface

The DP83850C has 64 registers held in two pages of 32 (Register Page 0 and Register Page 1). The registers are 16 bits wide. Only one page of registers can be accessed at a time.

After power-up and/or reset, the DP83850C defaults to Register Page 0. Register Page 1 can be accessed by writing 0001h to the PAGE register in Register Page 0, whereupon further accesses will be to Register Page 1.

3.0 Functional Description (Continued)

Subsequently writing 0000h to the PAGE register in Register Page 1 switches the registers back to Register Page 0.

All accesses to DP83850C registers and counters, and to the connected Physical Layer devices (via the DP83850C), are performed serially using the RDIO and RDC pins. The RDC clock is limited to a frequency no greater than 2.5MHz. This interface implements the serial management protocol defined by the MII specification, IEEE 802.3u clause 22. The protocol uses bit streams with the following format:

For Read operation: <start><opcode><device addr><reg addr> [turnaround] 0<data>.

For Write operation: <start><opcode><device addr><reg addr> <10><data>.

This protocol allows for up to 32 devices (DP83850Cs or other MII compliant devices) to be connected, each with a unique address and up to 32 16-bit registers. Devices are cascaded on the RDIO and RDC signals.

Since the RDIO pin is shared for both read and write operations, it must only be driven at the proper time. The serial protocol assumes that there is only one master (generally, the management entity's processor) and one or more slave devices (generally, the Physical Layer or DP83850C chips). The master drives RDIO at all times except when, during a slave read operation, the addressed slave places the serialized read data onto the RDIO line after the line turnaround field's first bit.

For unmanaged systems that do not use the DP83856 100RIB device for repeater management, it is important to provide the 100RIC with a minimum of 3 cycles of RDC during device reset. If the minimum number of cycles of RDC is not provided, the Serial Register Access Logic block may not be properly reset and as a result RDIO may not function properly. The 100RIB provides continuous RDC cycles, and eliminates this concern.

The fields of the protocol are defined in Table 3-1. In order for the protocol to work, all serial logic must first be "synchronized" to incoming data. A preamble of 32 consecutive 1's transmitted before the <start> field ensures "data lock".

3.0 Functional Description (Continued)

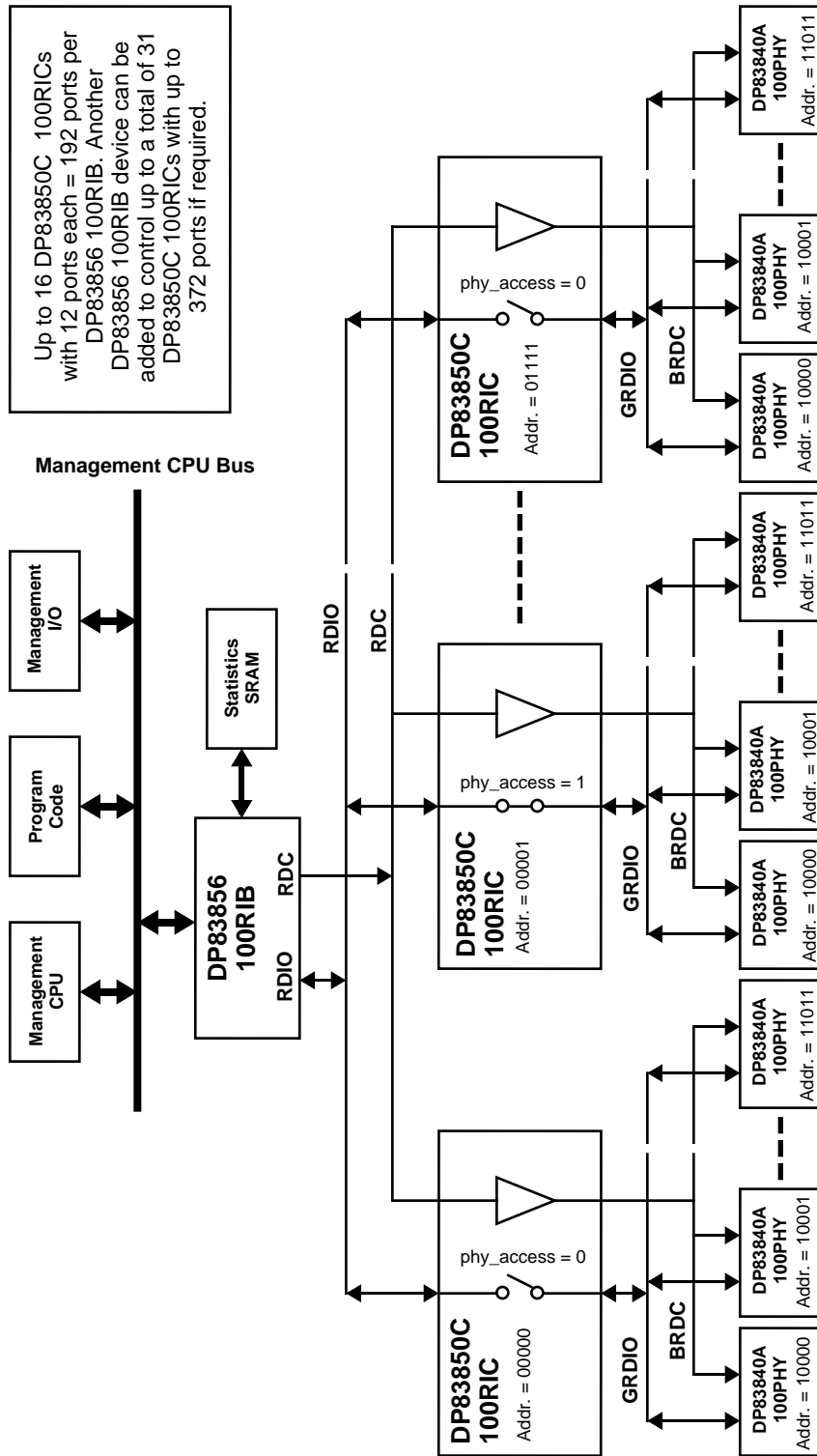

Figure 3. Serial Management Addressing Scheme

3.0 Functional Description (Continued)

This preamble only needs to be sent once (at reset). From then on, the <start> field lets the receive logic know where the beginning of the data frame occurs.

To access the Physical Layer devices via the serial bus, the DP83850C has a "phy_access" mode. When in this mode, the register data input/output (RDIO) is gated to the GRDIO pin. This signal is connected to the serial data pins of the Physical Layer devices.

In this mode the buffers which drive RDIO and GRDIO will turn on in the appropriate direction for each serial access. In order to avoid possible contention problems, the user must ensure that only one DP83850C at a time has the "phy_access" bit set. The CONFIG register contains the "phy_access" bit, which can be set or cleared at any time.

Figure 3 shows a possible system implementation of the RDIO/GRDIO connection scheme. In this example, the DP83850C with address 00001 has its "phy_access" bit set, allowing its twelve DP83840 PHY devices to be accessed by the DP83856 100RIB.

MII serial management contention problems can be avoided by keeping to the addressing convention shown in Figure 3.

3.12 Jabber/Partition LED Driver Logic

This logic encodes the current auto-partition status (from the PARTITION register) and the jabber status (from the JABBER register), and outputs this information to PART[5:0] pins. PART[3:0] cycles through each port number and PART[5:4] indicates the port's status. PART[5] indicates the Jabber status for each port (0 = LED OFF, 1 = LED ON - Port Jabbering). PART[4] indicates the Partition status for each port (0 = LED OFF, 1 = LED ON - Port Auto-Partitioned).

The port number on PART[3:0] is cycled with a 25MHz. External logic is required to decode the PART[5:0] outputs and drive the Partition and Jabber LEDs. Multi-color LEDs could be driven with the appropriate logic if required.

One possible implementation of a DP83850C Port Partition and Jabber Status LED scheme is given in section 5.5.

Table 1. Serial Register Interface Encoding

Field	Encoding	Description
<start>	01	Indicates the beginning of an opcode operation.
<opcode>	10	Read
	01	Write
	all others	Reserved
<reg addr>	00000 - 11111	Five bits are provided to address up to 32 16-bit registers.
<device addr>	00000 - 11111	Five bits are provided to address up to 32 devices.

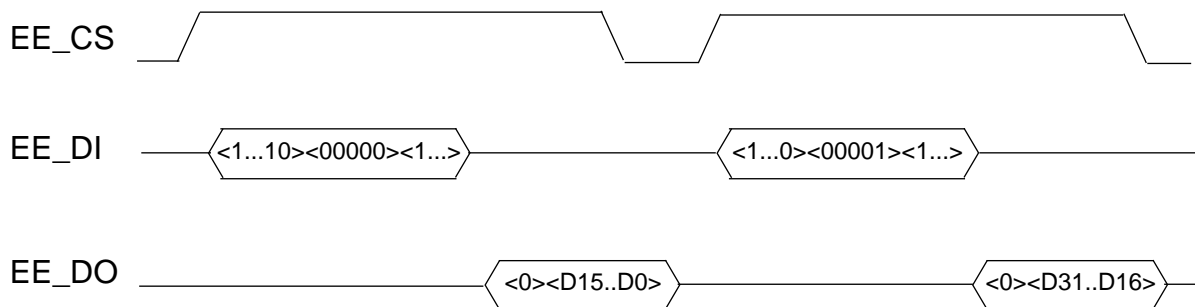

Figure 4. Serial EEPROM Access Protocol

3.13 EEPROM Serial Read Access

After reset is de-asserted, the DP83850C will serially read an NM93C06 EEPROM (or equivalent). Only the first 32-bits starting from address 0 will be read. Write access is not provided. The data is written to registers HUBID0 and HUBID1. The first bit read is written to HUBID0[0]; the last bit read will be written to HUBID1[15].

The DP83850C EEPROM interface implements the serial protocol as shown in Figure 3. The DP83850C will issue two read commands to obtain the 32-bit ID. The serial clock, EE_CK will be continuous. For more explicit timing diagrams please refer to the NM93C06 datasheet.

The NM93C06 EEPROM must be pre-programmed with the HUBID value prior to fitting the device to the circuit since the DP83850C does not support programming of this device in circuit.

4.0 Registers

The DP83850C has 64 registers in 2 pages of 32 16-bit registers. At power-on and/or reset, the DP83850C defaults to Page 0 registers. The register page can be changed by writing to the PAGE register in either register page. The register page maps are given in sections 4.1 and 4.2, followed by a detailed description of the registers in sections 4.3 to 4.12.

4.1 Page 0 Register Map

Address (hex)	Name	Access	Description
0	CONFIG	r/w	Sets the DP83850C configuration.
1	PAGE	r/w	Selects either register page 0 or 1.
2	PARTITION	read only	Indicates Auto-Partitioning status.
3	JABBER	read only	Indicates Jabber status.
4	ADMIN	r/w	Port enable/disable, administration control/status.
5	DEVICEID	r/w	Accesses a) the DP83850C ID number configured externally on the RID[4:0] pins and b) the last receiving port number. The DP83850C device number may be overwritten after it has been latched at the end of reset: be careful not to have duplicate ID's on the same IR bus interface.
6	HUBID0	read only	First 16 bits read from EEPROM.
7	HUBID1	read only	Second 16 bits read from EEPROM.
8	P0_SE	r/w	Port 0: 32-bit ShortEvent counter (See access rules section 4.11).
9	P0_LE	r/w	Port 0: 32-bit LateEvent counter (See access rules section 4.11).
A	P0_COL	r/w	Port 0: 32-bit Collision counter (See access rules section 4.11).
B	P0_PART	r/w	Port 0: 16-bit Auto-Partition counter.
C	P1_SE	r/w	Port 1: 32-bit ShortEvent counter (See access rules section 4.11).
D	P1_LE	r/w	Port 1: 32-bit LateEvent counter (See access rules section 4.11).
E	P1_COL	r/w	Port 1: 32-bit Collision counter (See access rules section 4.11).
F	P1_PART	r/w	Port 1: 16-bit Auto-Partition counter.
10 - 13	P2_SE ... P2_PART	r/w	Port 2 management counters (as per ports 0, 1 above).
14 - 17	P3_SE ... P3_PART	r/w	Port 3 management counters (as per ports 0, 1 above).
18 - 1B	P4_SE ... P4_PART	r/w	Port 4 management counters (as per ports 0, 1 above).
1C - 1F	P5_SE ... P5_PART	r/w	Port 5 management counters (as per ports 0, 1 above).

4.0 Registers (Continued)

4.2 Page 1 Register Map

Address (hex)	Name	Access	Description
0	CONFIG	r/w	Sets the DP83850C configuration (same as page 0 CONFIG register).
1	PAGE	r/w	Select either register page 0 or 1.
2	-	-	Reserved
3	-	-	Reserved
4	SIREV	read only	Silicon revision code.
5 - 7	-	-	Reserved
8 - B	P6_SE ... P6_PART	r/w	Port 6 management counters (as per ports 0, 1 above).
C - F	P7_SE ... P7_PART	r/w	Port 7 management counters (as per ports 0, 1 above).
10 - 13	P8_SE ... P8_PART	r/w	Port 8 management counters (as per ports 0, 1 above).
14 - 17	P9_SE ... P9_PART	r/w	Port 9 management counters (as per ports 0, 1 above).
18 - 1B	P10_SE ... P10_PART	r/w	Port 10 management counters (as per ports 0, 1 above).
1C - 1F	P11_SE ... P11_PART	r/w	Port 11 management counters (as per ports 0,1 above).

4.3 Configuration Register (CONFIG)

Page 0 Address 0h

Page 1 Address 0h

Bit	Bit Name	Access	Bit Description
D15 - D6	reserved	-	For compatibility with future enhanced versions these bits must be written as zero. They are undefined when read.
D5	REGEN_PRE	r/w	Regenerate Preamble: This bit may be used to overwrite/change the repeater mode (TX or T4) that is set by the MODE[1:0] pins at power-up. If MODE[1:0] is 1, 1 then this bit is set, otherwise this bit will be zero. The time when the preamble is regenerated depends upon the type of the PHY (either TX or T4 PHYs) attached to the repeater. For a TX PHY, preamble is regenerated approximately 4 clocks (RXC) after the /IR_ACTIVE assertion, and for a T4 PHY, preamble is regenerated approximately 12 clocks after the /IR_ACTIVE assertion.
D4	MGTEN	r/w	Management Enable: This bit enables all the management counters. 0: Management Counters disabled (default). 1: Management Counters enabled. Note: The management counters can only be reliably written to when they are disabled.
D3	COL_LIMIT32	r/w	This bit configures the collision limit for Auto-Partitioning algorithm: 0: Consecutive Collision Limit set to 64 consecutive collisions (default). A port will be partitioned on the 65th consecutive collision. 1: Consecutive Collision Limit set to 32 consecutive collisions. A port will be partitioned on the 33rd consecutive collision.
D2	DIS_PART	r/w	This bit disables the Auto-Partitioning algorithm: 0: Auto-Partitioning is not disabled (default). 1: Auto-Partitioning is disabled.

4.0 Registers (Continued)

Bit	Bit Name	Access	Bit Description
D1	PHY_ACCESS	r/w	This bit allows the management agent to access the DP83840A PHY chip's register via the MII serial protocol. 0: PHY access disabled (default). 1: PHY register access enabled. Note: When in PHY_access mode, RDIO will be driven by the DP83850C during the read phase for all read commands. This is to allow the DP83840A Physical Layer devices to pass their data through their local DP83850C. While in this mode, contention will result (on the RDIO line) if any device other than this DP83850C or the DP83840A Physical Layer devices are accessed.
D0	RST_RSM	r/w	Setting this bit holds the Repeater State Machines in reset. The management event flags and counters are unaffected by this bit. Setting this bit while a reception is in progress may truncate the packet. 0: DP83850C in normal operation (default). 1: DP83850C held in reset.

4.4 Page Register (PAGE)

Page 0 Address 1h

Page 1 Address 1h

Bit	Bit Name	Access	Bit Description
D15 - D2	reserved	-	These bits are undefined when read. Must be written as 0.
D1 - D0	PAGE[1:0]	r/w	These bits program the register page to be accessed. The page encoding is as follows: PAGE[1:0] Page 0h 0 (default) 1h 1 2h reserved 3h reserved

4.5 Partition Status Register (PARTITION)

Page 0 Address 2h

Bit	Bit Name	Access	Bit Description
D15 - D12	reserved	-	These bits are undefined when read.
D11 - D0	PART[11] ... PART[0]	read only	The respective port's PART bit is set to 1 when Partitioning is sensed on that port. After reset, these bits are cleared to zero.

4.6 Jabber Status Register (JABBER)

Page 0 Address 3h

Bit	Bit Name	Access	Bit Description
D15 - D12	reserved	-	These bits are undefined when read.
D11 - D0	JAB[11..0]	read only	The respective port's JAB bit is set to 1 when the Jabber condition is detected on that port. After reset, these bits are cleared to zero.

4.0 Registers (Continued)

4.7 Administration Register (ADMIN)

Page 0 Address 4h

Bit	Bit Name	Access	Bit Description
D15 - D13	reserved	-	For compatibility with future enhanced versions these bits must be written as zero. They are undefined when read.
D12	TST_PART_LED	r/w	Test Partition LED: When this bit is set, the corresponding Partition LED logic will be enabled if any of the ADMIN_DIS bits are set.
D11 - D0	ADMIN_DIS[11] ... ADMIN_DIS[0]	r/w	Setting these bits to 0 enables the respective port (TX and RX). Writing a 1 to any bit will disable that port. Note that port enable/disable actions will occur at the next network idle period. For example, if an ADMIN_DIS bit is cleared during an incoming packet, this port will only be enabled after the incoming packet has finished. After reset, these bits default to zero (all ports enabled).

4.8 Device ID Register (DEVICEID)

Page 0 Address 5h

Bit	Bit Name	Access	Bit Description
D15 - D13	reserved	-	For compatibility with future enhanced versions these bits must be written as zero. They are undefined when read.
D12	T4_PHY_DET	r/w	T4 PHY detected: This bit indicates that a T4 PHY is detected. The criteria for detection of T4 PHY is that /IRD_V must be asserted approximately 5 IRD_CLKs after the /IR_ACTIVE assertion and the SFD is also seen. This bit remains set until reset by a register write or a reset has been applied to the repeater.
D11 - D8	PORT_NUM	read only	Port Number: These bits indicate the last or current receiving port number.
D7	EE_DONE	read only	EEPROM Access Done: This bit is set when the DP83850C has completed its read of the EEPROM.
D6	reserved	-	For compatibility with future enhanced versions these bits must be written as zero. They are undefined when read.
D5	RID_ER	r/w	Repeater ID Error: This bit is set under two conditions: <ol style="list-style-type: none"> 1. When this DP83850C sees another DP83850C use the same RID number as its own on the management bus, or, 2. RID[4:0] has been programmed with a value of 1Fh. This bit sticks to 1 until it is cleared by a register write.
D4 - D0	RPTR_ID	r/w	Device ID: These bits are the source for the IR_VECT[4:0] pins. These bits also supply the register address for MII serial bus accesses. At the rising edge of /RST, the levels on RID[4:0] are latched in this register as D[4:0]. Note 1: While you can write to these bits at any time, caution must be used. First, when a new value is entered, all subsequent accesses must be performed at this new address. Second, if an RID number is chosen that is that is the same as another DP83850C device, both of these devices will be rendered unreadable (there will be contention). Recovery from this condition is only possible with a complete system reset, since it will not be possible to write new unique RID's to the contending DP83850Cs. Note 2: Since IR_VECT = 1Fh is an illegal value, D[4:0] must not be written to this value.

4.9 Hub ID 0 Register (HUBID0)

Page 0 Address 6h

Bit	Bit Name	Access	Bit Description
D15 - D0	HUB_ID0[15:0]	r/w	Hub ID 0: Contains the first 16 bits read from the EEPROM. The first bit read will be written to HUB_ID0[0]; the last bit read to HUB_ID0[15].

4.0 Registers (Continued)

4.10 Hub ID 1 Register (HUBID1)

Page 0

Address 7h

Bit	Bit Name	Access	Bit Description
D15 - D0	HUB_ID1[15:0]	r/w	Hub ID 1: Contains the second 16 bits read from the EEPROM. The first bit read will be written to HUB_ID1[0]; the last bit read to HUB_ID1[15].

4.11 Port Management Counter Registers

Each of the 12 ports of the DP83850C has a set of 4 event counters whose values can be read or pre-set (written) through the Port Management Counter Registers. Ports 0 through 5 have their registers in register page 0 and ports 6 through 11 in register page 1.

All counters will rollover to zero after reaching their maximum count: they are not "sticky". There is no interrupt on reaching maximum count, so the management software must ensure the registers are polled often enough so as not to rollover twice; management software can deduce a single rollover as long as the counter has not yet reached the previously read value (a simple compare). It is safest for the management software to guarantee to check all counters at least once per possible rollover time. All counters are cleared to zero at power-on and/or reset (/RST asserted).

The Short Event, Late Event and Collision Counters are 32-bits long. Since the corresponding Counter Registers are only 16-bits, the DP83850C has to internally multiplex the counter value into two 16-bit values that the management software must then concatenate to form the full 32-bit value. Some restrictions apply to the access of the counter registers:

1. A 32-bit counter must be read as two consecutive 16-bit accesses. Upon the first access, the DP83850 places the full 32-bit counter value in a holding register, from where it transfers the upper 16 bits first. The second access reads the lower 16 bits of the counter. If there is any access to another register in between the counter reads, the concatenated value of the counter will be invalid (the DP83850C's internal multiplexer will reset).
2. For the same reason, a 32-bit counter must be written as two consecutive 16-bit accesses.
3. All counters are cleared by writing 0000 0000h to them. The counter value is unaffected by read accesses.
4. The counters should only be written to when they are disabled. This is done by deasserting the MGTEN bit in the CONFIG register.

4.12 Silicon Revision Register (SIREV)

Page 1

Address 4h

Bit	Bit Name	Access	Bit Description
D15 - D0	SI_REV[15:0]	read only	Silicon revision - currently reads all 0's.

4.11.1 Short Event Counter Registers

Per port ('n' = port number) counters that indicate the number of Carrier Events that were active for less than the ShortEventMaxTime, which is defined as between 74 and 82 (76 nominal) bit times.

Bit	Access	Bit Description
D15 - D0	r/w	First access - most significant word of P'n'_SE Second access - least significant word of P'n'_SE

4.11.2 Late Event Counter Registers

Per port ('n' = port number) counters that indicate the number of collisions that occurred after the LateEventThreshold, which is defined to be 480 to 565 bit times (512 nominal). Both the Late Event and Collision Counters will be incremented when this event occurs.

Bit	Access	Bit Description
D15 - D0	r/w	First access - most significant word of P'n'_LE Second access - least significant word of P'n'_LE

4.11.3 Collision Counter Registers

Per port ('n' = port number) counters that indicate the number of collisions (COL asserted).

Bit	Access	Bit Description
D15 - D0	r/w	First access - most significant word of P'n'_COL Second access - least significant word of P'n'_COL

4.11.4 Auto-Partition Counter Registers

Per port ('n' = port number) counters that indicate the number of times the port was auto-partitioned.

Bit	Access	Bit Description
D15 - D0	r/w	P'n'_PART

5.0 DP83850C Applications

5.1 MII Interface Connections

The DP83850C's interface to DP83840A PHY devices is fully described in the Application Note – AN1069 "100BASE-TX Unmanaged Repeater Design Recommendations". Designers should be aware that there are significant issues involved in the signal timing, loading and layout of this interface and they should consult this Applica-

tion Note and/or their National Semiconductor representative prior to attempting a design. Further system timing analysis shows that the RXD[3:0], RX_DV and RX_ER signals should be latched into the DP83850C from the connected DP83840s. Figure 5 shows the recommended scheme. This ensures system timing can be met for hub stacks.

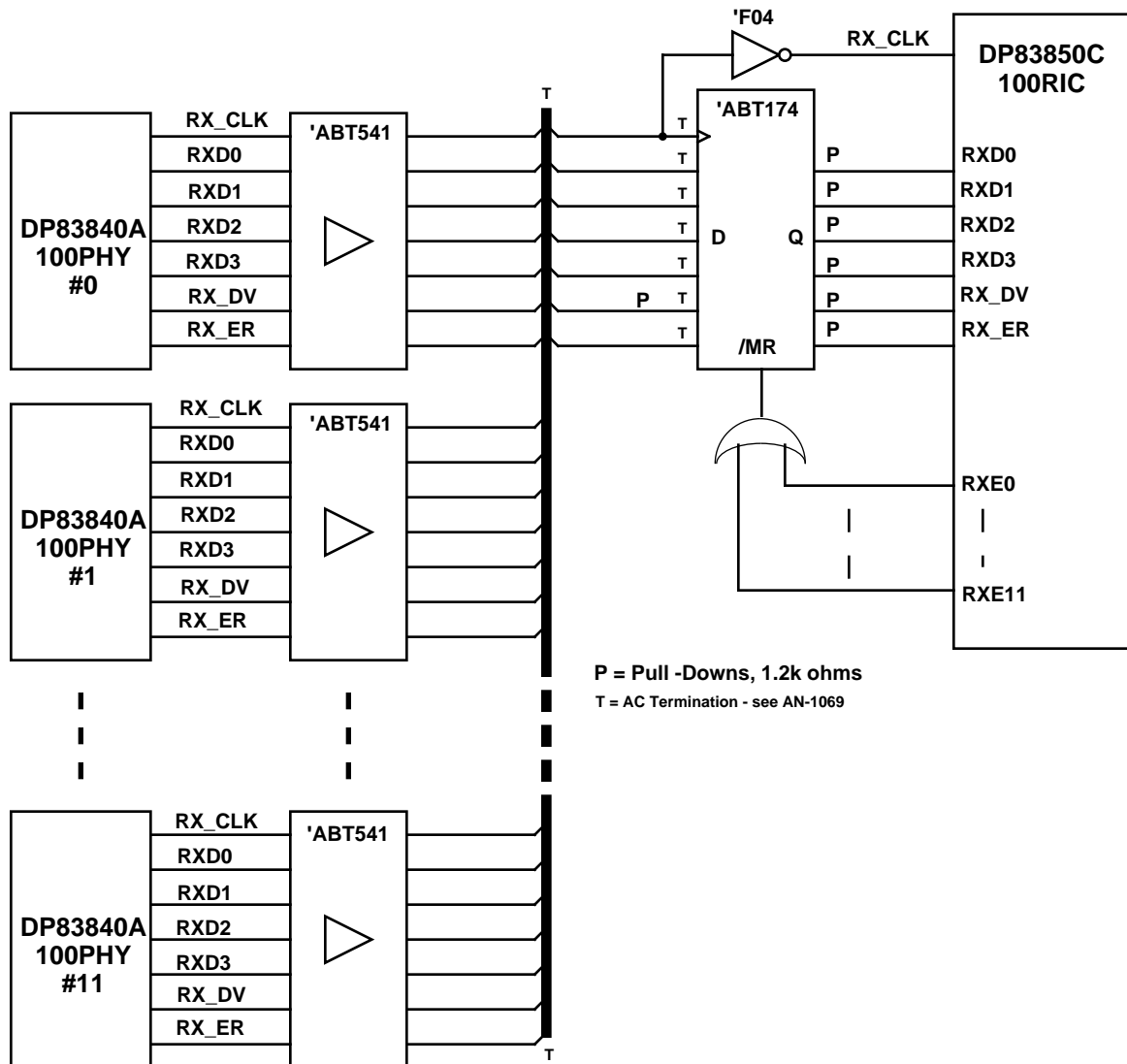

Figure 5. Recommended DP83840A to DP83850C Connections

5.2 Repeater ID Interface

The repeater ID interface is shown in Figure 6. It consists of a bank of DIP switches or links to set the RID number for the DP83850C to use as its IR_VECT[4:0] number.

5.3 Inter Repeater Bus Connections

For a simple stand-alone repeater that cannot be stacked, no inter repeater bus transceivers/drivers are required and the inter repeater bus interface is simple. An example of this is shown in Figure 7.

For a stackable hub design, the DP83850C's Inter Repeater Bus connections are complex and have many issues regarding signal timing, loading and layout. An example design for a TTL level inter repeater bus is given in Figure 8. It should be noted that this is a single example of possible connections to an inter repeater bus. There are many other possible ways to design this interface. Designers should be aware that timing, particularly skew between clock and data, is critical. For this reason, the use of LS, S, TTL, or CMOS logic drivers is not recommended. The ABT family of logic is recommended, as well as the FAST® family could possibly be made to work too. Also recommended

5.0 DP83850C Applications (Continued)

is the BTL logic transceiver family: this approach has the advantage of significantly lower noise and may assist in successful passing of FCC and other EMI tests.

Figure 8 shows the signal connections on the Inter-RIC bus. The pull up resistors on the DP83850C should be a minimum of 1.2 k Ω . Lower values may be required depending on layout/loading, especially on the /ACTIVE0 and /IR_ACTIVE signals where short deassertion time is

critical. The value of the pull up resistor terminations on the inter repeater bus backplane will depend upon the bus loading. The values should be chosen so that the signals on the bus have fast enough edges to meet the DP83850C inter repeater bus timings. The inter repeater bus will need to be terminated properly at each end to prevent signal reflections from causing problems

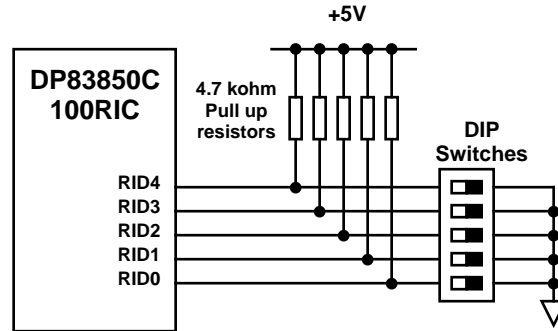

Figure 6. DP83850C Repeater ID Number Interface

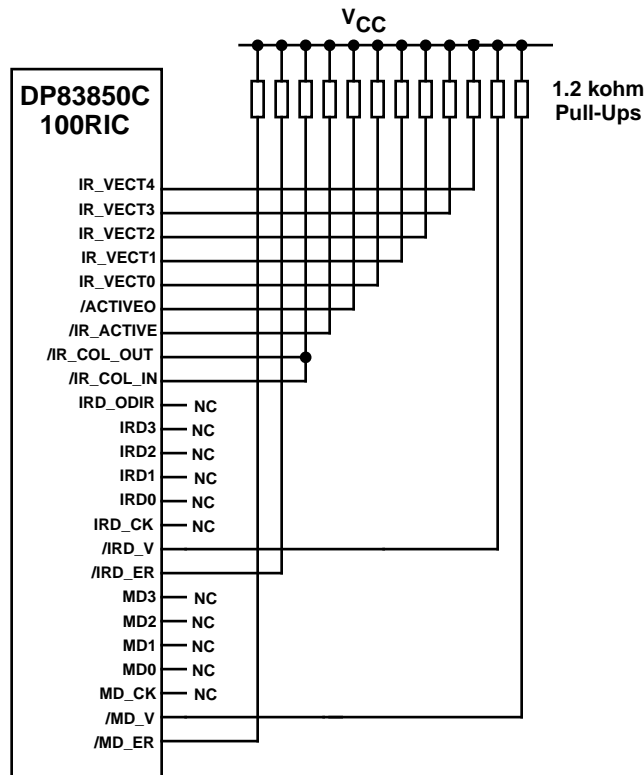

Figure 7. DP83850C Stand-alone Inter Repeater Bus Interface

5.0 DP83850C Applications (Continued)

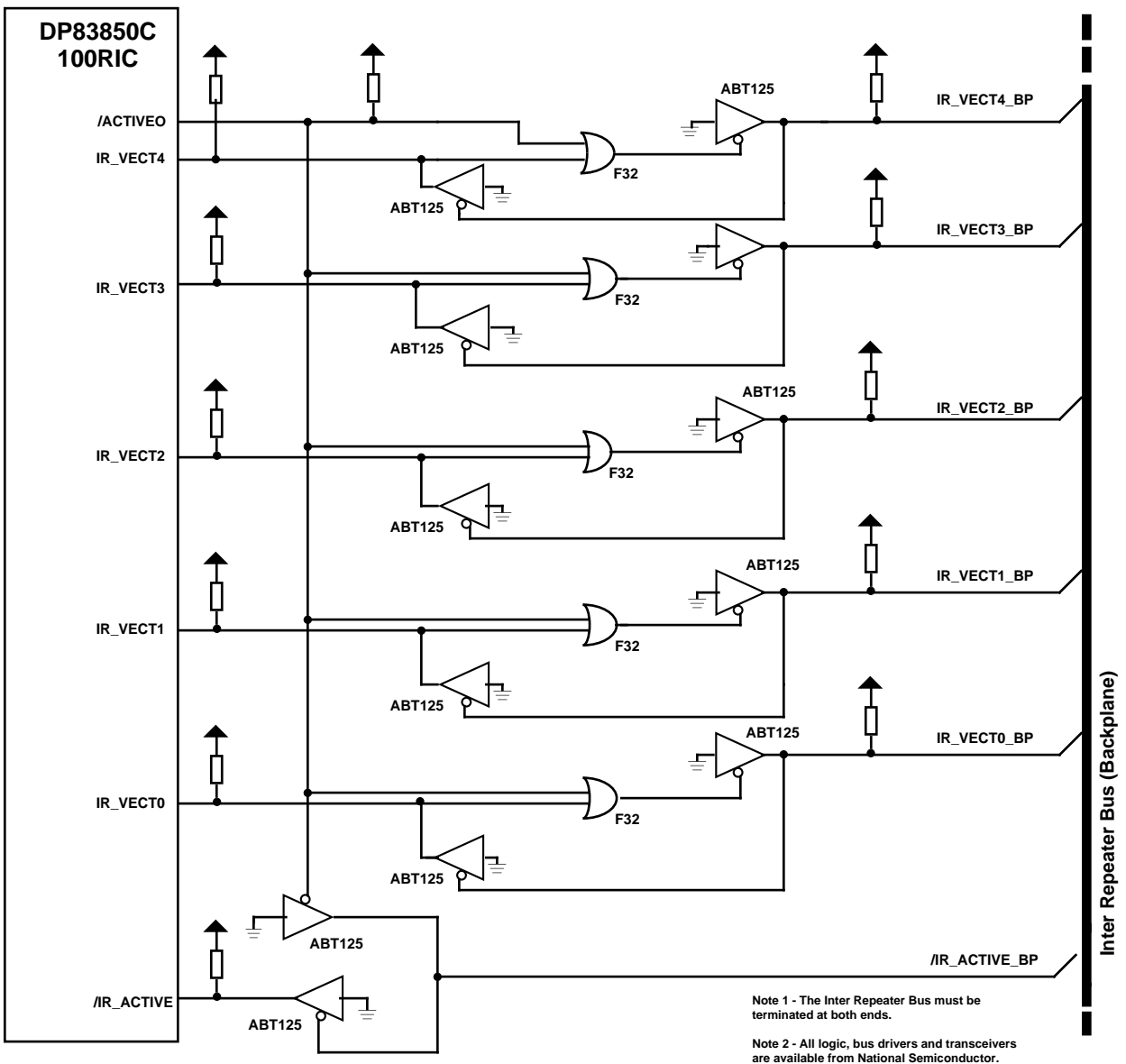
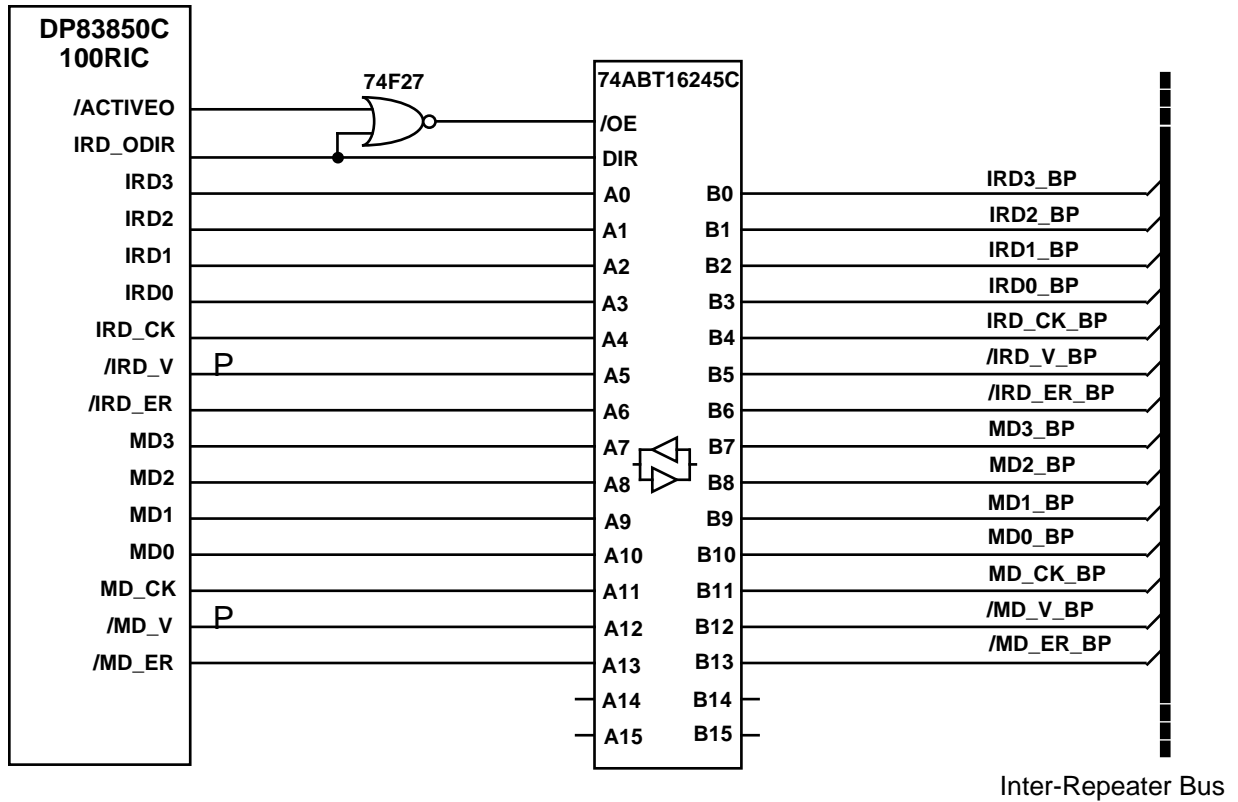

Figure 8. Inter Repeater Bus Connections

5.0 DP83850C Applications (Continued)



P = Pull-Ups, 1.2k ohms

Figure 9. Inter Repeater Bus Connections

5.0 DP83850C Applications (Continued)

5.4 DP83856 100RIB Connections

To achieve a practical managed 100Mb/s repeater design that keeps up with the fast flow of network information, a hardware statistics gathering engine is required. The DP83856 100Mb/s Repeater Information Base device (100RIB) is specifically designed to work with the DP83850C to provide such a design. In a multi-100RIC system, one of the 100RIC devices has to be chosen to source the transmit data bus to the 100RIB. This 100RIC is

known as the "Local 100RIC" since is likely to be the nearest one (physically) to the 100RIB on the circuit board. All the other signals that the 100RIB requires in order to keep statistics are common to all the other 100RICs. Figure 10 shows a typical connection between the 100RIC and the 100RIB. Note that, depending on board layout, track lengths and loading, buffers (not shown) may be required on some signals.

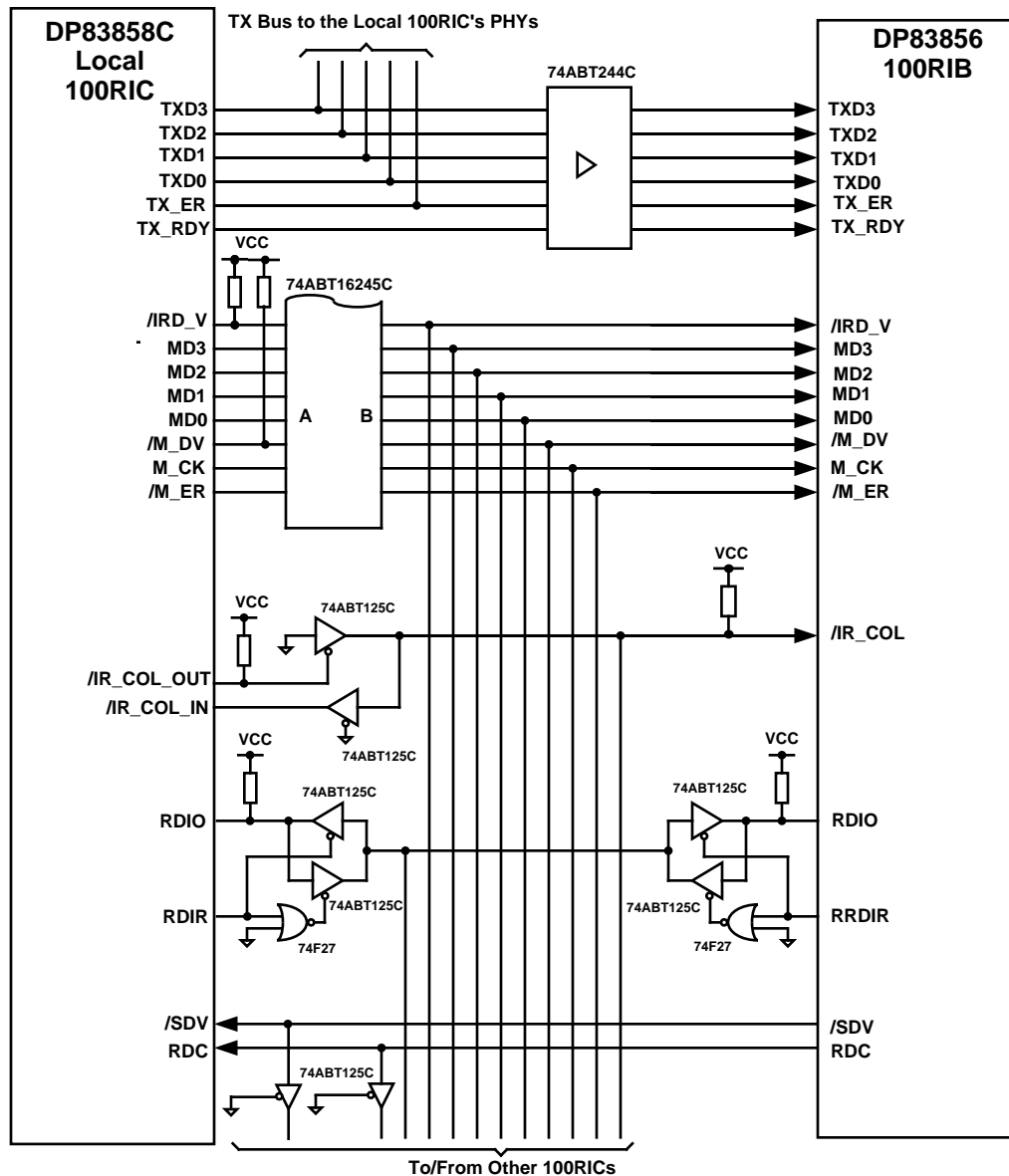

Figure 10. Typical DP83850C to DP83856 Connections

5.0 DP83850C Applications (Continued)

5.5 Port Partition and Jabber Status LEDs

Port Partition and Jabber Status must be decoded from the PART[5:0] outputs as described in section 3.11. One possible decoder implementation is shown in Figure 11. This uses 74LS259 addressable latches to hold the LED status for each port. The lowest significant 3 bits of the port address (PART[2:0]) are directly connected to each of the

74LS259 addressable latches. The most significant address bit (PART3) and its inverse are gated by the system clock to produce low going pulses to the 74LS259 enables at the correct time.

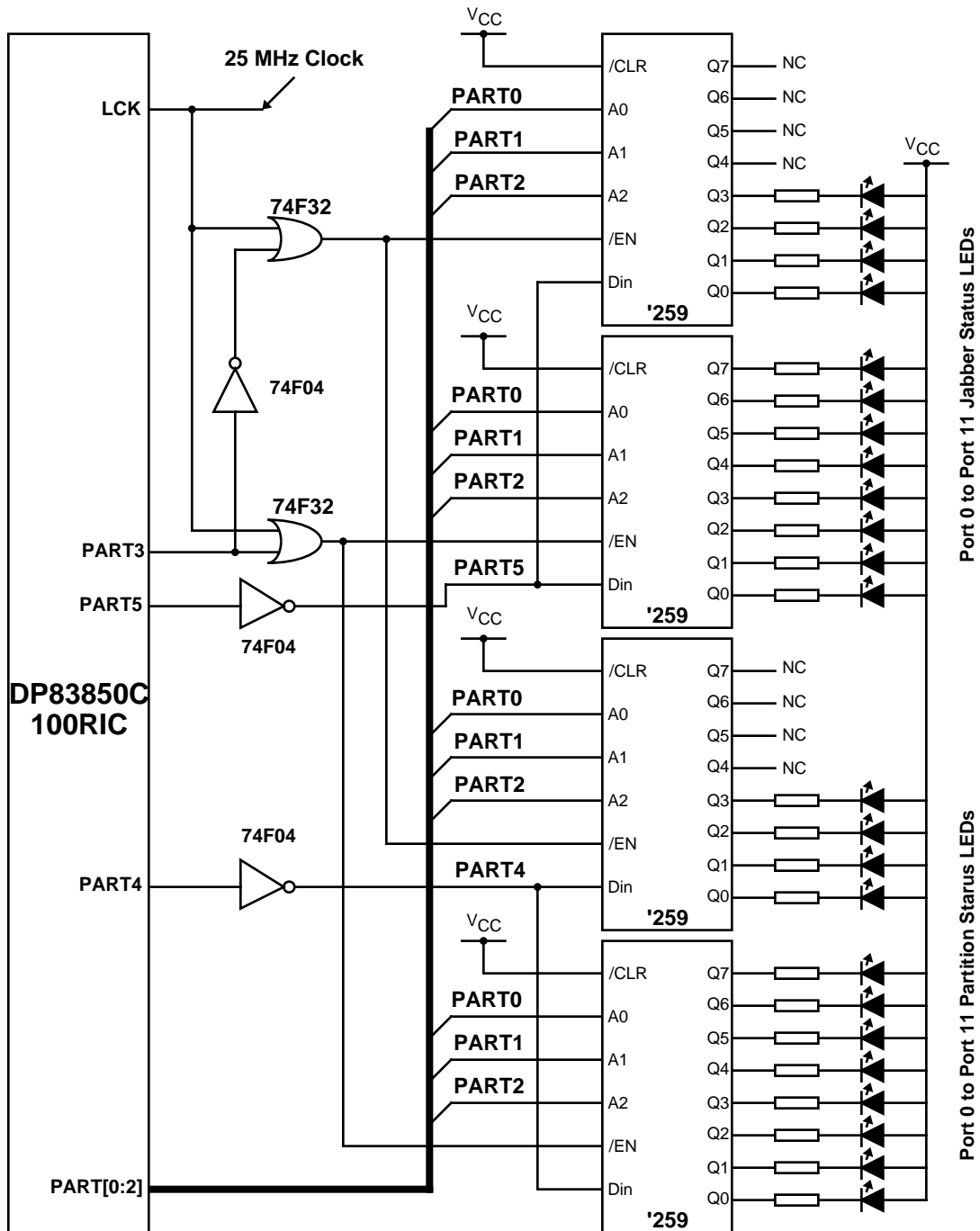

Figure 11. Implementation of a Jabber and Partition Status LED Scheme

6.0 A.C. and D.C. Specifications

Absolute Maximum Rating and Recommended Operating Conditions

Supply Voltage (Vdd)	-0.5 V to 7.0V	Storage Temperature Range (Tstg)	-65c to 150c
Supply voltage (Vdd)	5 volts + 5%	Power Dissipation (Pd)	1.575 W
DC Input Voltage (Vin)	-0.5 V to Vcc + 0.5 V	Lead Temp (TI) (soldering 10-sec)	260c
Ambient Temperature (Ta)	0 to 70c	ESD Rating 2.0KV (Rzap = 1.5k, Czap = 120pF)	
DC Output Voltage (Vout)	-0.5 V to Vcc + 0.5V		

Note: Absolute maximum ratings are those values beyond which the safety of the device cannot be guaranteed. They are not meant to imply that the device should be operated at these limits.

6.1 D.C. Specifications

Symbol	Parameter	Conditions	Min	Max	Units
V _{OH}	Minimum High Level Output Voltage		3.7		V
V _{OL}	Minimum Low Level Output Voltage	IOL = 4 mA		0.5	V
V _{IH}	Minimum High Level Input Voltage	TTL Input	2.0		V
V _{IL}	Maximum Low Level Input Voltage	TTL Input		0.8	V
I _{IN}	Input Current			±10	mA
I _{OL}	Maximum Low Level Output Current	TXD pins		24	mA
		TX_ER pins		12	
		IR Bus pins		12	
I _{OZ}	TRI-STATE Output Leakage Current			±10	µA
I _{CC}	TYPICAL Average Supply Current			295	mA

6.0 A.C. and D.C. Specifications (Continued)

6.2 A.C. Specifications

6.2.1 Receive Timing

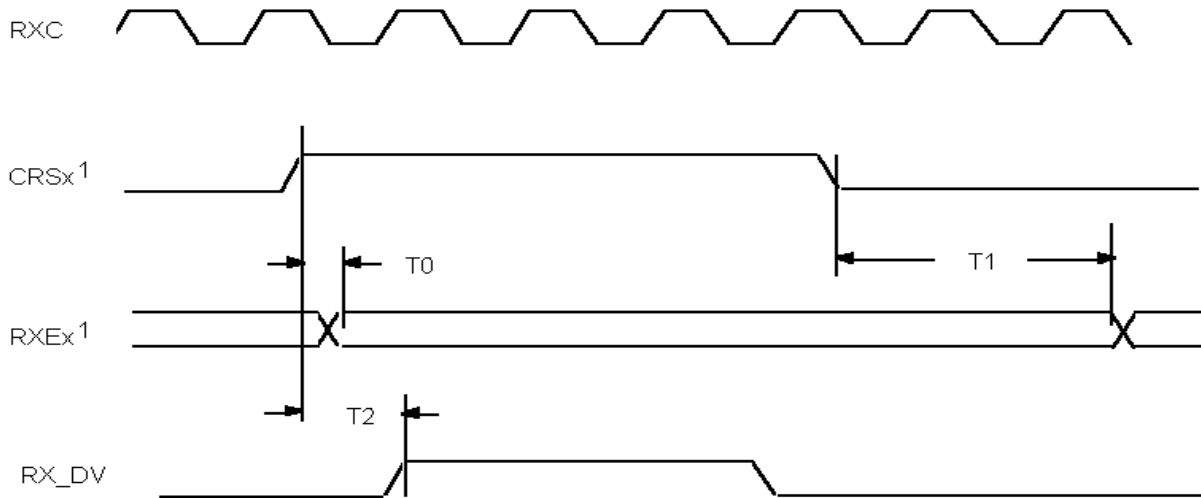

	Description	Min	Max	Units
T0	CRSx to RXEx assertion delay (Note 1)		18	ns
T1	CRSx to RXEx de-assertion delay with no collision	3	5	LCK
T2	CRSx to RX_DV delay requirement (Note 2)	40		ns

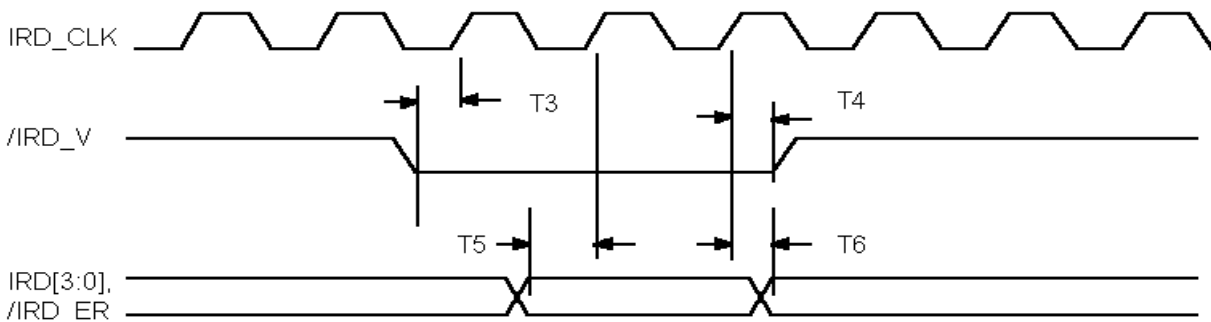

	Description	Min	Max	Units
T3	/IRD_V setup to IRD_CLK high	2		ns
T4	/IRD_V hold from IRD_CLK high	2		ns
T5	IRD[3:0] or /IRD_ER setup to IRD_CLK high	2		ns
T6	IRD[3:0] or /IRD_ER hold from IRD_CLK high	2		ns

Note 1: “CRSx” and “RXEx” refer to any of the CRS[11:0] signals. In the event of a collision (more than one CRS is active) none of the RXE signals will be asserted.

Note 2: If, after 4 RXC clocks from CRSx going high, no aligned data is received, the DP83850C 100RIC will repeat the JAM pattern.

6.0 A.C. and D.C. Specifications (Continued)

6.2.2 Transmit, Partition and RID_ER Timing

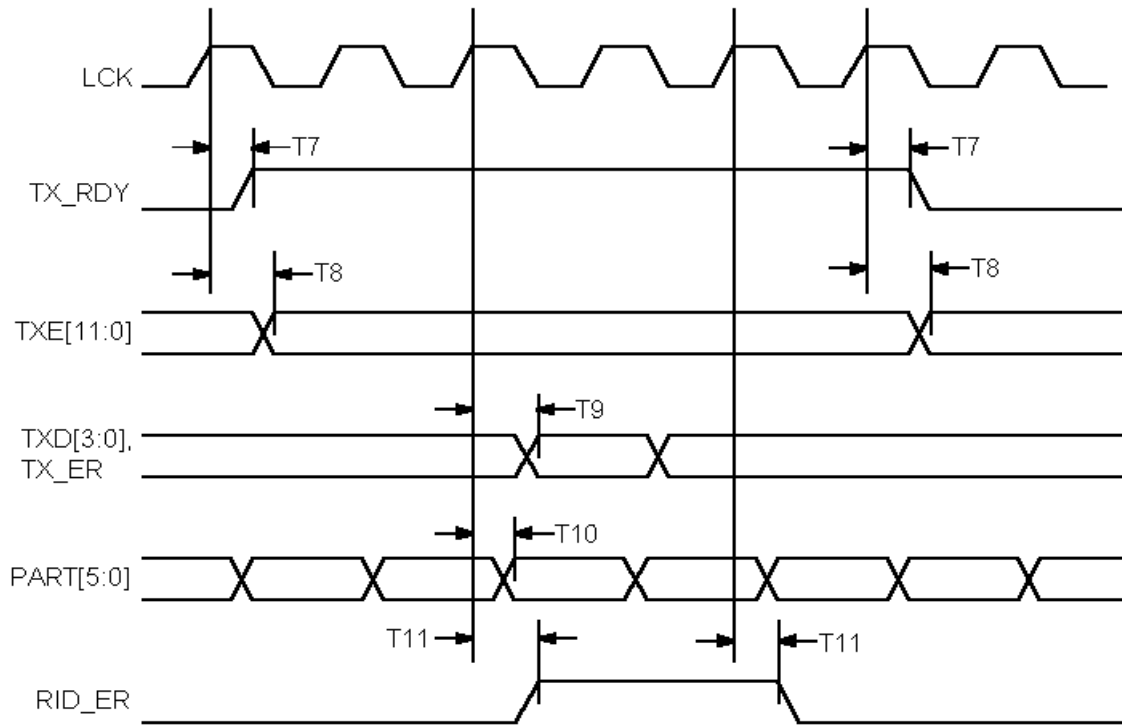

	Description	Min	Max	Units
T7	TX_RDY delay from LCK high	4	25	ns
T8	TXE[11:0] delay from LCK high	4	25	ns
T9	TXD[3:0] or TX_ER valid time from LCK high	4	21	ns
T10	PART[5:0] valid time from LCK high	4	25	ns
T11	RID_ER delay from LCK high	4	25	ns

6.0 A.C. and D.C. Specifications (Continued)

6.2.3 Inter Repeater Receive and Intra-Repeater Collision Timing

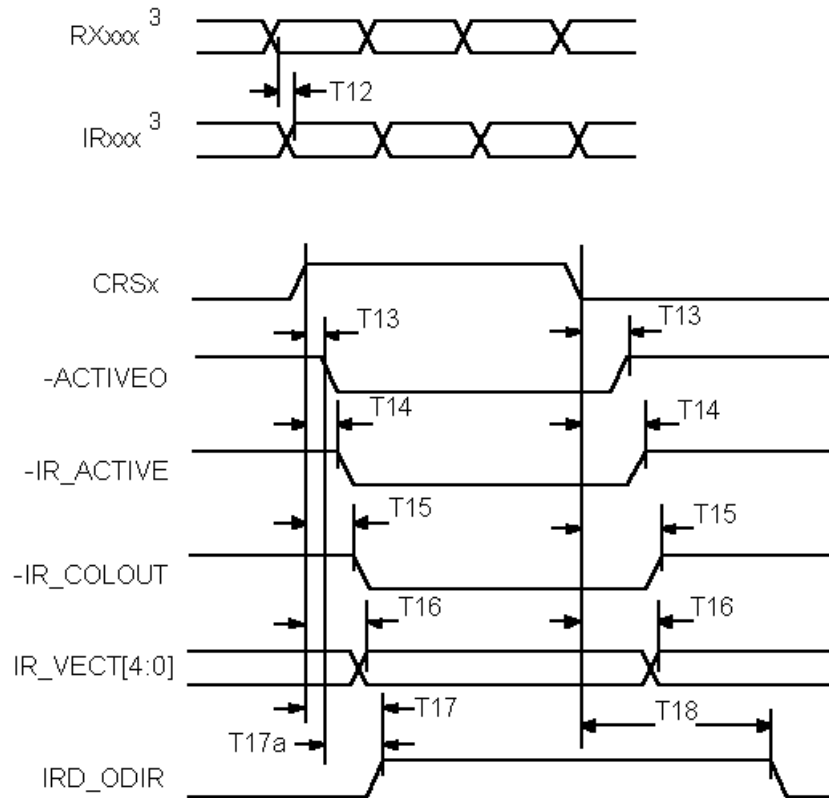

	Description	Min	Max	Units
T12	Receive to Inter Repeater Bus delay ³		10	ns
T12a	Receive to Inter Repeater Bus skew ⁴		2	ns
T13	CRSx assertion (de-assertion) to -ACTIVEO assertion (de-assertion) ⁵		20	ns
T14	CRSx assertion (de-assertion) to /IR_ACTIVE assertion (de-assertion) ⁵		20	ns
T15	CRSx assertion (de-assertion) to /IR_COL_OUT assertion (de-assertion) ^{5,6}		18	ns
T16	CRSx assertion (de-assertion) to IR_VECT[4:0] assertion (de-assertion) ⁵		20	ns
T17	CRSx assertion to IRD_ODIR assertion with no collision ^{5,8}		36	ns
T17a	/ACTIVEO to IRD_ODIR delay ⁸	6.5		ns
T18	CRSx de-assertion to IRD_ODIR de-assertion ^{5,7}	4	6	LCK

Note 3: "RXxxx" refers to any of the receive signals, i.e. RXC, RXD[3:0], RX_DV, or RX_ER. "IRxxx" refers to any of the Inter Repeater signals, i.e. IRD_CK, IRD[3:0], /IRD_V, or /IRD_ER.

Note 4: This parameter refers to the delta in delay between any of the Inter Repeater signals.

Note 5: "CRSx" refers to any of CRS[11:0] signals being asserted.

Note 6: This timing refers to the assertion of /IR_COL_OUT during an internal collision, that is when 2 or more CRSx signals are asserted in the same DP83850C.

Note 7: This timing refers only to the condition where only one CRSx is present. IRD_ODIR will be deasserted immediately if a collision occurs.

Note 8: The assertion of IRD_ODIR is also dependent upon an equality comparison on IR_VECT[4:0]. These timings reflect a direct feedback path at the IR_VECT I/O pins. If external buffers are used, then these timings are increased by the external delay of the buffers.

6.0 A.C. and D.C. Specifications (Continued)

6.2.4 Inter Repeater Collision Timing

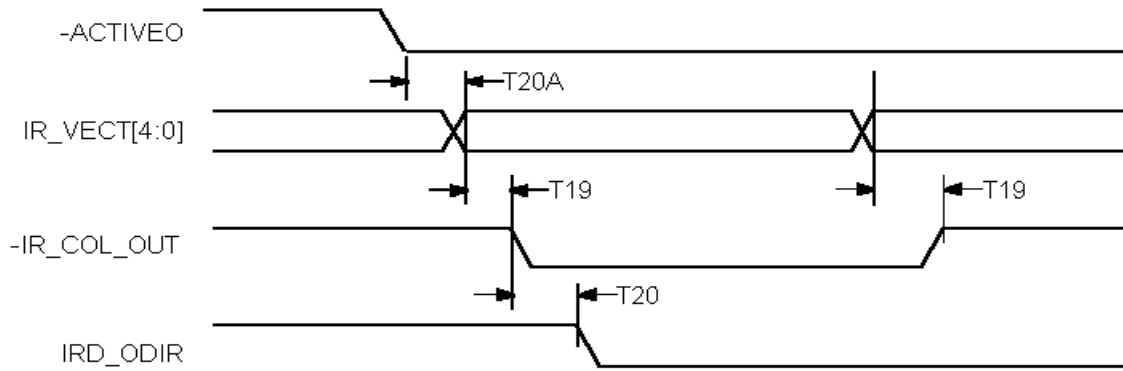

	Description	Min	Max	Units
T19	IR_VECT[4:0] change to /IR_COL_OUT assertion[de-assertion] ⁹		17	ns
T20	/IR_COL_OUT assertion to IRD_ODIR de-assertion		15	ns
T20A	/ACTIVEO low to IR_VECT[4:0] feedback ^{10,11}		20	ns

Note 9: This timing refers to the condition where the repeater has detected a change from its driven arbitration vector to what is seen on the IR_VECT[4:0] bus. In other words, an “Inter Repeater” collision is occurring.

Note 10: This timing refers to the condition where the DP83850C first drives its vector onto IR_VECT[4:0] at the beginning of a packet. The IR_VECT[4:0] feedback (possibly returning from an external bus) must be stable by this time.

Note 11: Guaranteed By Design.

6.2.5 Management Bus - Output Mode Timing

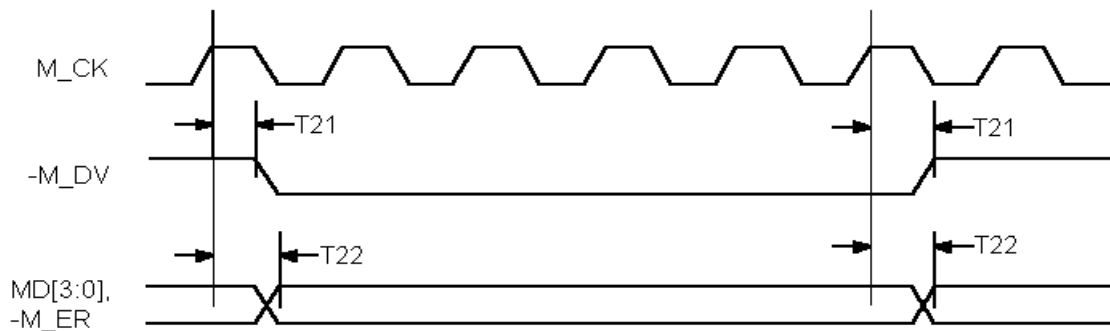

	Description	Min	Max	Units
T21	/M_DV assertion [de-assertion] from M_CK high	4	15	ns
T22	MD[3:0] or /M_ER valid from M_CK high	4	15	ns
T23	Removed			

6.0 A.C. and D.C. Specifications (Continued)

6.2.6 Management Bus - Input Mode Timing

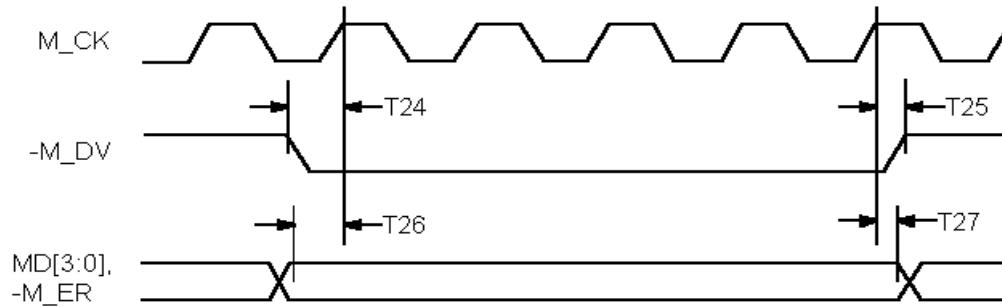

	Description	Min	Max	Units
T24	/M_DV setup to M_CK high	5		ns
T25	/M_DV hold from M_CK high	1		ns
T26	MD[3:0] or /M_ER setup to M_CK high	5		ns
T27	MD[3:0] or /M_ER hold from M_CK high	1		ns

6.0 A.C. and D.C. Specifications (Continued)

6.2.7 Serial Register Write Timing

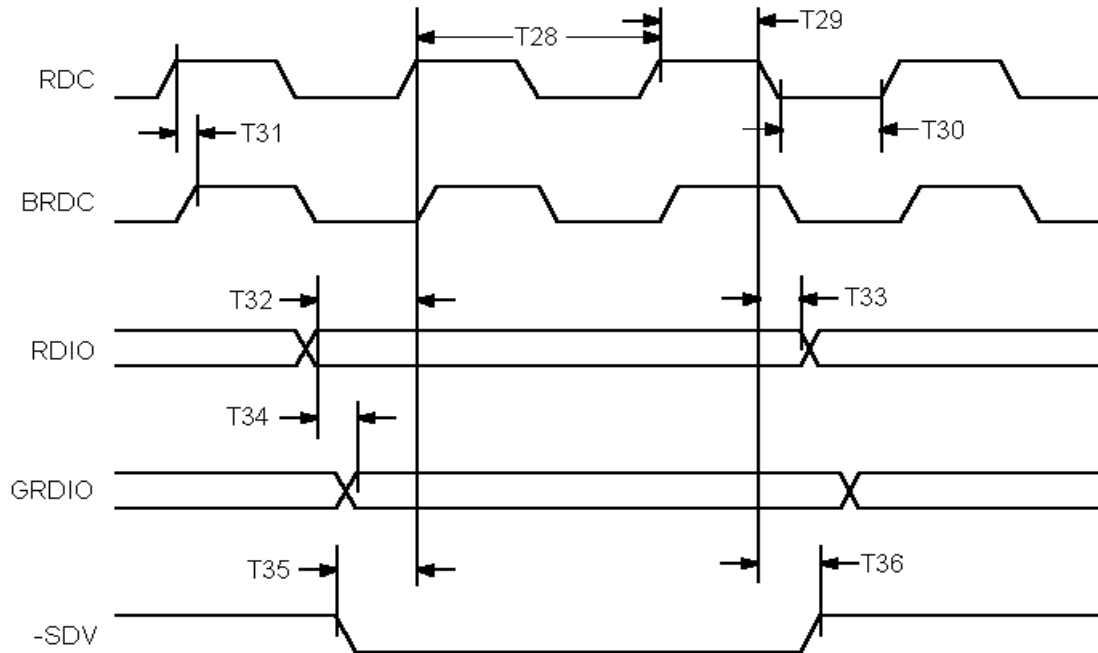

	Description	Min	Max	Units
T28	RDC period		400	ns
T29	RDC high time ¹²	40		ns
T30	RDC low time ¹²	40		ns
T31	RDC to BRDC delay		25	ns
T32	RDIO setup to RDC high	10		ns
T33	RDIO hold from RDC high	10		ns
T34	RDIO to GRDIO delay ¹³		25	ns
T35	/SDV setup to RDC high	10		ns
T36	/SDV hold from RDC high	10		ns

Note 12: Although the high or low time may be as small as 40ns, the RDC cycle time is limited to 2.5 MHz.

Note 13: Serial data will be gated from RDIO to GRDIO during write operation when the "phy_access" bit in the CONFIG register is set.

6.0 A.C. and D.C. Specifications (Continued)

6.2.8 Serial Register Read Timing

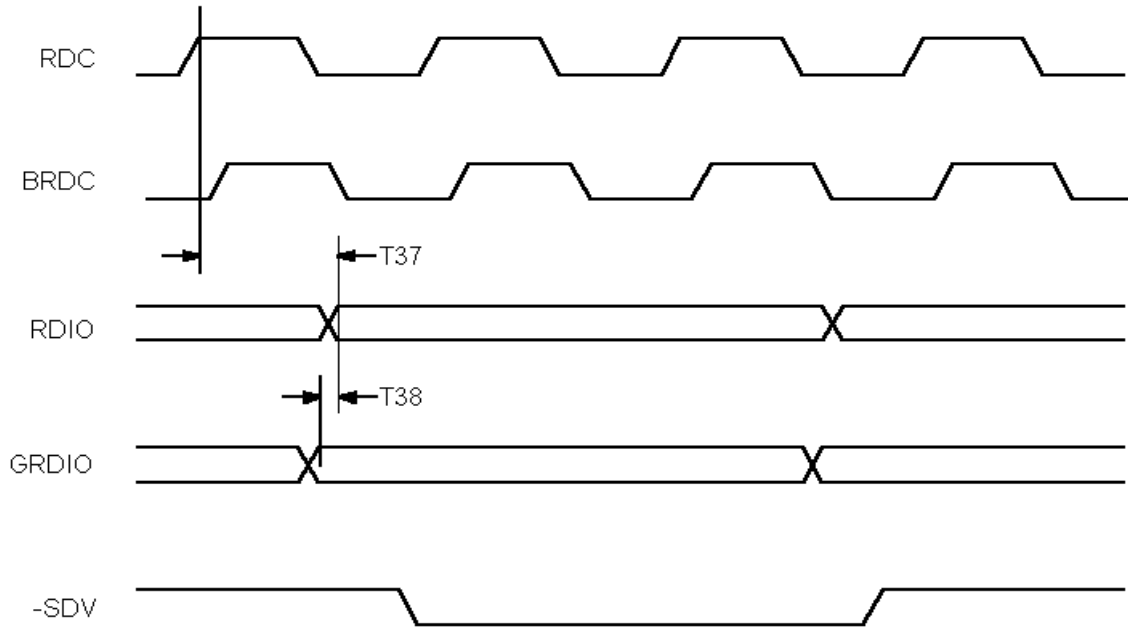

	Description	Min	Max	Units
T37	RDIO valid from RDC		25	ns
T38	GRDIO to RDIO delay ¹⁴		25	ns

Note 14: Serial data will be gated from GRDIO to RDIO during read operations when the “phy_access” bit in the CONFIG register is set.

6.0 A.C. and D.C. Specifications (Continued)

6.2.9 EEPROM Access Timing

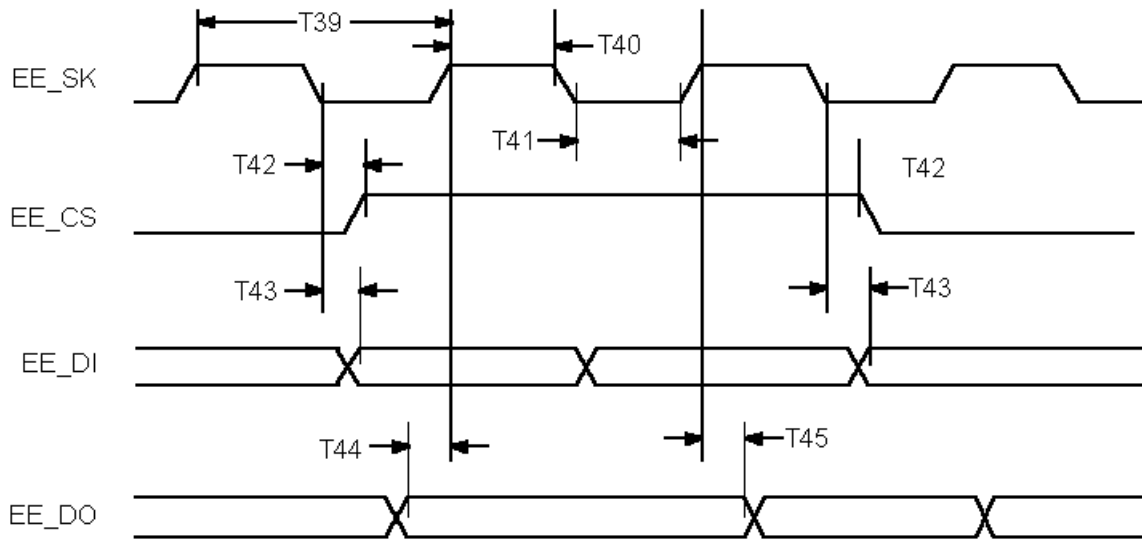

	Description	Min	Max	Units
T39	EE_SK period ¹⁵		1280 (nom)	ns
T40	EE_SK high time ¹⁵		640 (nom)	ns
T41	EE_SK low time ¹⁵		640 (nom)	ns
T42	EE_CS assertion [de-assertion] from EE_SK low	30	45	ns
T43	EE_DI assertion [de-assertion] from EE_SK low	30	45	ns
T44	EE_DO setup to EE_SK high		10	ns
T45	EE_DO hold from EE_SK high	40		ns

Note 15: These timings are nominal (untested) values.

6.0 A.C. and D.C. Specifications (Continued)

6.2.10 Clocks, Reset and RID Timing

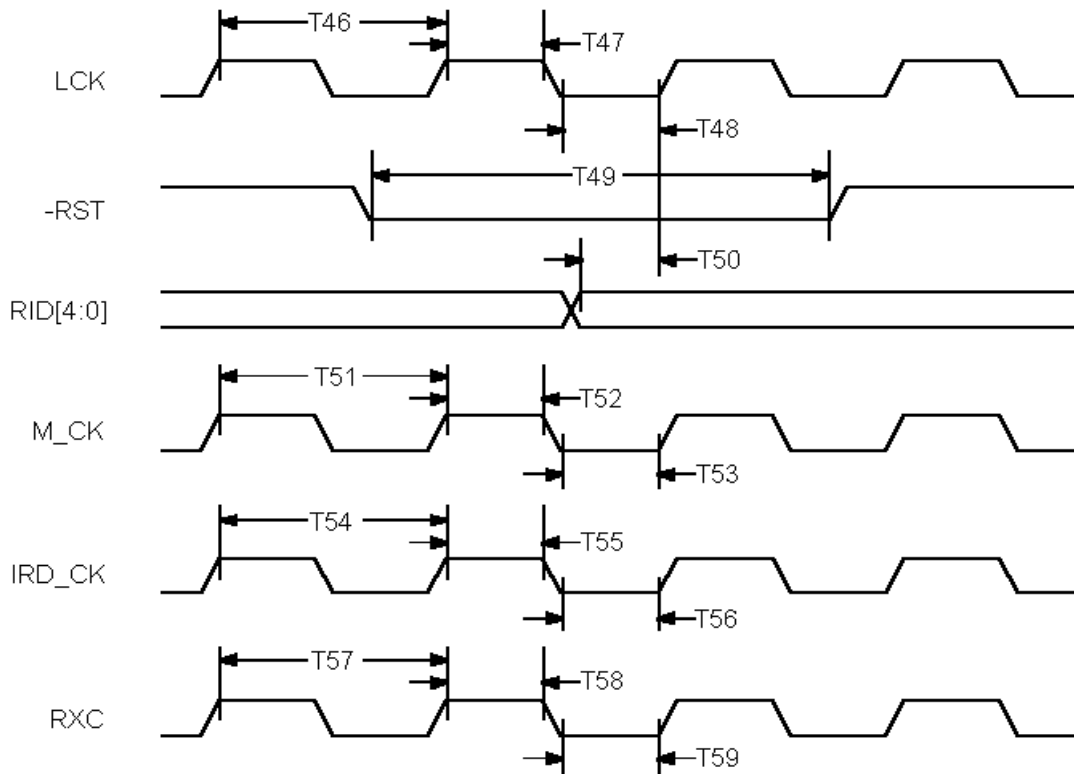

	Description	Min	Max	Units
T46	LCK period	40	40	ns
T47	LCK high time	16		ns
T48	LCK low time	16		ns
T48a	LCK frequency tolerance ¹⁶		50 or 100	ppm
T49	/RST assertion time	75		LCK
T50	RID[4:0] setup to LCK high	20		ns
T51	M_CK period (input mode)	40	40	ns
T52	M_CK high time (input mode)	16		ns
T53	M_CK low time (input mode)	16		ns
T54	IRD_CK period (input mode)	40	40	ns
T55	IRD_CK high time (input mode)	16		ns
T56	IRD_CK low time (input mode)	16		ns
T57	RXC period	40		ns
T58	RXC high time	14		ns
T59	RXC low time	14		ns
T60	RXC frequency tolerance ¹⁶		50 or 100	ppm

Note 16: In systems where preamble regeneration is not enabled, the clock tolerance is 50 ppm, otherwise it is 100 ppm.

7.0 Physical Dimensions inches (millimeters) unless otherwise noted

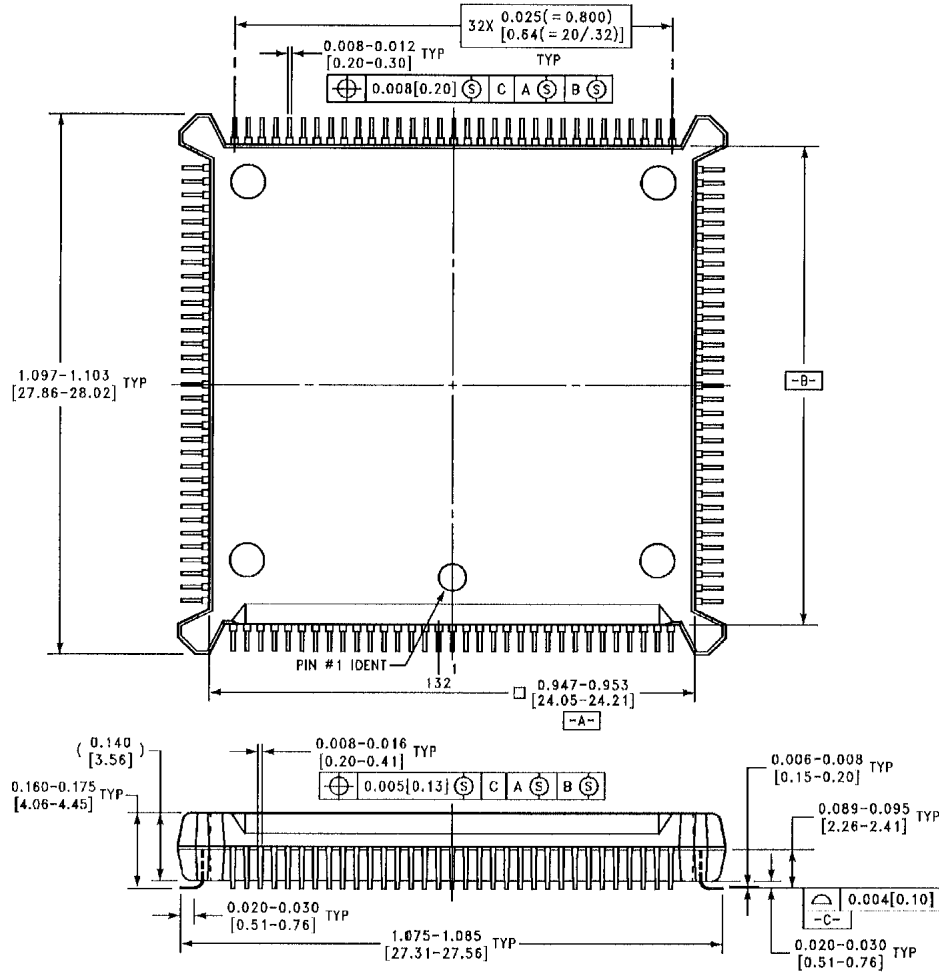

**132-Lead Molded Plastic Quad Flat Package, JEDEC
Order Number DP83850C
NS Package Number VF132A**

LIFE SUPPORT POLICY

NATIONAL'S PRODUCTS ARE NOT AUTHORIZED FOR USE AS CRITICAL COMPONENTS IN LIFE SUPPORT DEVICES OR SYSTEMS WITHOUT THE EXPRESS WRITTEN APPROVAL OF THE PRESIDENT OF NATIONAL SEMICONDUCTOR CORPORATION. As used herein:

1. Life support devices or systems are devices or systems which, (a) are intended for surgical implant into the body, or (b) support or sustain life, and whose failure to perform, when properly used in accordance with instructions for use provided in the labeling, can be reasonably expected to result in a significant injury to the user.
2. A critical component is any component of a life support device or system whose failure to perform can be reasonably expected to cause the failure of the life support device or system, or to affect its safety or effectiveness.



National Semiconductor Corporation
1111 West Bardin Road
Arlington, TX 76017
Tel: 1(800) 272-9959
Fax: 1(800) 737-7018

National Semiconductor Europe
Fax: (+49) 0-180-530 85 86
Email: europe.support@nsc.com
Deutsch Tel: (+49) 0-180-530 85 85
English Tel: (+49) 0-180-532 78 32

National Semiconductor Asia Pacific Customer Response Group
Tel: 65-254-4466
Fax: 65-250-4466
Email: sea.support@nsc.com

National Semiconductor Japan Ltd.
Tel: 81-043-299-2308
Fax: 81-043-299-2408

www.national.com