

## DM64ALS374A/DM74ALS374A Octal TRI-STATE® D-Type Edge-Triggered Flip-Flop

### General Description

These 8-bit registers feature totem-pole TRI-STATE outputs designed specifically for driving highly-capacitive or relatively low-impedance loads. The high-impedance state and increased high-logic-level drive provide these registers with the capability of being connected directly to and driving the bus lines in a bus-organized system without need for interface or pull-up components. They are particularly attractive for implementing buffer registers, I/O ports, bidirectional bus drivers, and working registers.

The eight flip-flops of the ALS374A are edge-triggered D-type flip-flops. On the positive transition of the clock, the Q outputs will be set to the logic states that were set up at the D inputs.

A buffered output control input can be used to place the eight outputs in either a normal logic state (high or low logic levels) or a high-impedance state. In the high-impedance state the outputs neither load nor drive the bus lines significantly.

The output control does not affect the internal operation of the flip-flops. That is, the old data can be retained or new data can be entered even while the outputs are off.

The DM64ALS374A version features the same performance as the standard version DM74ALS374A with a guarantee over an extended temperature range ( $-40^{\circ}\text{C}$  to  $+85^{\circ}\text{C}$ ).

### Features

- Switching specifications at 50 pF
- Switching specifications guaranteed over full temperature and  $V_{CC}$  range
- Advanced oxide-isolated, ion-implanted Schottky TTL process
- Functionally and pin-for-pin compatible with LS TTL counterpart
- Improved AC performance over LS374 at approximately half the power
- TRI-STATE buffer-type outputs drive bus lines directly
- DM64ALS374A guarantee over extended temperature  $-40^{\circ}\text{C}$  to  $+85^{\circ}\text{C}$

### Connection Diagram

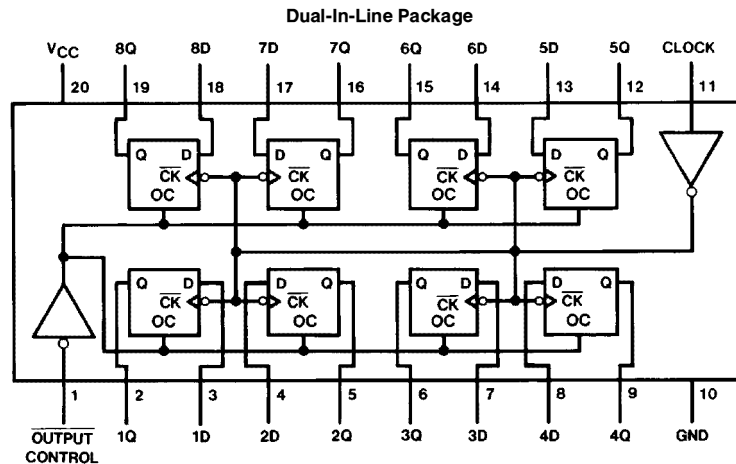

Order Number DM64ALS374AN, DM64ALS374AWM, DM74ALS374AWM, DM74ALS374AN or DM74ALS374ASJ  
See NS Package Number M20B, M20D or N20A

TL/F/6113-1

TRI-STATE® is a registered trademark of National Semiconductor Corporation.

## Absolute Maximum Ratings

Supply Voltage	7V
Input Voltage	7V
Voltage Applied to Disabled Output	5.5V
Operating Free Air Temperature Range	
DM64ALS	−40°C to +85°C
DM74ALS	0°C to +70°C
Storage Temperature Range	−65°C to +150°C
Typical $\theta_{JA}$	
N Package	60.0°C/W
M Package	79.0°C/W

Note: The "Absolute Maximum Ratings" are those values beyond which the safety of the device cannot be guaranteed. The device should not be operated at these limits. The parametric values defined in the "Electrical Characteristics" table are not guaranteed at the absolute maximum ratings. The "Recommended Operating Conditions" table will define the conditions for actual device operation.

Note: This product meets application requirements of 500 temperature cycles from −65°C to +150°C.

## Recommended Operating Conditions

Symbol	Parameter	DM64ALS374A			DM74ALS374A			Units
		Min	Nom	Max	Min	Nom	Max	
$V_{CC}$	Supply Voltage	4.5	5	5.5	4.5	5	5.5	V
$V_{IH}$	High Level Input Voltage	2			2			V
$V_{IL}$	Low Level Input Voltage			0.8			0.8	V
$I_{OH}$	High Level Output Current			−2.6			−2.6	mA
$I_{OL}$	Low Level Output Current			24			24	mA
$f_{CLOCK}$	Clock Frequency	0		35	0		35	MHz
$t_w$	Width of Clock Pulse	High	14		14			ns
		Low	14		14			ns
$t_{SU}$	Data Setup Time	10 ↑			10 ↑			ns
$t_H$	Data Hold Time	0 ↑			0 ↑			ns
$T_A$	Free Air Operating Temperature	−40		85	0		70	°C

The (↑) arrow indicates the positive edge of the Clock is used for reference.

## Electrical Characteristics

over recommended operating free air temperature range. All typical values are measured at  $V_{CC} = 5V$ ,  $T_A = 25^\circ C$ .

Symbol	Parameter	Conditions	Min	Typ	Max	Units	
$V_{IK}$	Input Clamp Voltage	$V_{CC} = 4.5V$ , $I_I = -18 mA$			−1.5	V	
$V_{OH}$	High Level Output Voltage	$V_{CC} = 4.5V$	$I_{OH} = Max$	2.4	3.2	V	
		$V_{CC} = 4.5V$ to $5.5V$	$I_{OH} = -400 \mu A$	$V_{CC} - 2$		V	
$V_{OL}$	Low Level Output Voltage	$V_{CC} = 4.5V$	$I_{OL} = 12 mA$		0.25	0.4	V
			$I_{OL} = 24 mA$		0.35	0.5	V
$I_I$	Input Current @ Max. Input Voltage	$V_{CC} = 5.5V$ , $V_{IH} = 7V$			0.1	mA	
$I_{IH}$	High Level Input Current	$V_{CC} = 5.5V$ , $V_{IH} = 2.7V$			20	$\mu A$	
$I_{IL}$	Low Level Input Current	$V_{CC} = 5.5V$ , $V_{IL} = 0.4V$			−0.2	mA	
$I_O$	Output Drive Current	$V_{CC} = 5.5V$ , $V_O = 2.25V$	−30		−112	mA	
$I_{OZH}$	Off-State Output Current, High Level Voltage Applied	$V_{CC} = 5.5V$ , $V_O = 2.7V$			20	$\mu A$	
$I_{OZL}$	Off-State Output Current, Low Level Voltage Applied	$V_{CC} = 5.5V$ , $V_O = 0.4V$			−20	$\mu A$	
$I_{CC}$	Supply Current	$V_{CC} = 5.5V$ Outputs Open	Outputs High		11	19	mA
			Outputs Low		19	28	mA
			Outputs Disabled		20	31	mA

## Switching Characteristics over recommended operating free air temperature range (Note 1)

Symbol	Parameter	Conditions	From	To	DM64ALS374A		DM74ALS374A		Units
					Min	Max	Min	Max	
f <sub>MAX</sub>	Maximum Clock Frequency	V <sub>CC</sub> = 4.5V to 5.5V R <sub>L</sub> = 500Ω C <sub>L</sub> = 50 pF			35		35		MHz
t <sub>PLH</sub>	Propagation Delay Time Low to High Level Output		Clock	Any Q	3	12	3	12	ns
t <sub>PHL</sub>	Propagation Delay Time High to Low Level Output		Clock	Any Q	5	16	5	16	ns
t <sub>PZH</sub>	Output Enable Time to High Level Output		Output Control	Any Q	3	17	3	17	ns
t <sub>PZL</sub>	Output Enable Time to Low Level Output		Output Control	Any Q	5	18	5	18	ns
t <sub>PHZ</sub>	Output Disable Time from High Level Output		Output Control	Any Q	1	10	1	10	ns
t <sub>PLZ</sub>	Output Disable Time from Low Level Output		Output Control	Any Q	2	18	2	18	ns

**Note 1:** See Section 5 for test waveforms and output load.

## Function Table

Output Control	Clock	D	Output Q
L	↑	H	H
L	↑	L	L
L	L	X	Q <sub>0</sub>
H	X	X	Z

L = Low State, H = High State, X = Don't Care

↑ = Positive Edge Transition

Z = High Impedance State

Q<sub>0</sub> = Previous Condition of Q

# Logic Diagram

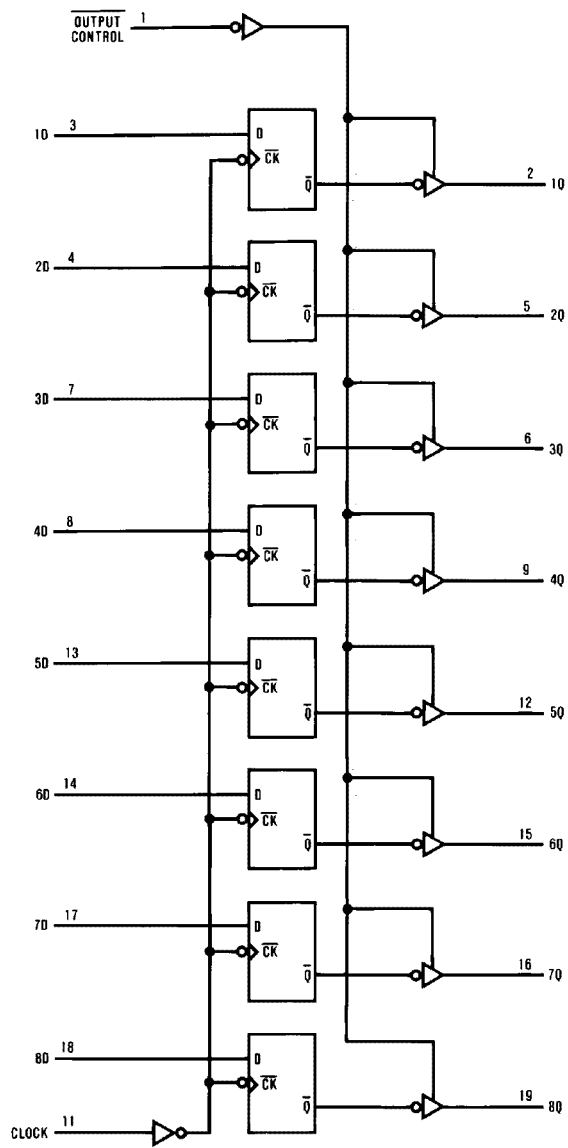

TL/F/6113-2

**Physical Dimensions** inches (millimeters)

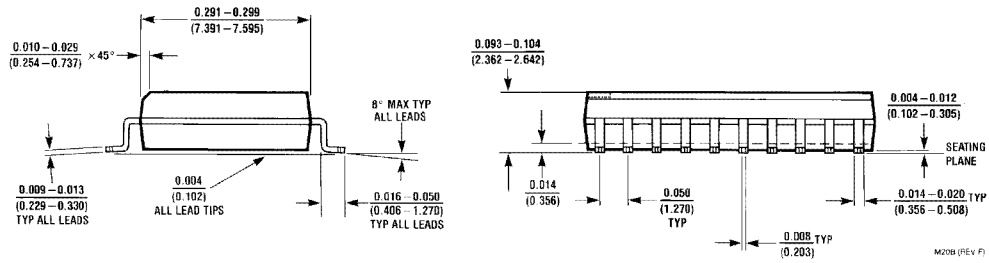
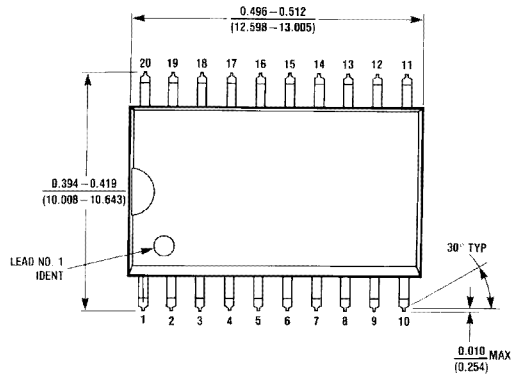

**S.O. Package (M)**  
**Order Number DM64ALS374AWM, DM74ALS374AWM**  
**NS Package Number M20B**

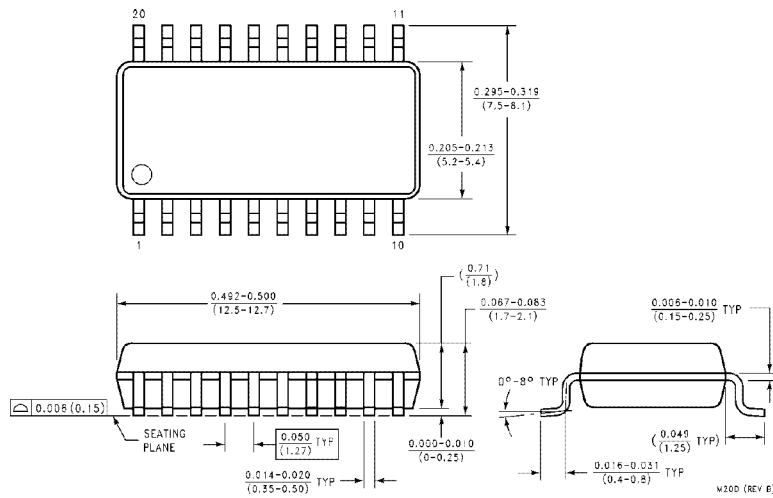

**Small Outline Package (SJ)**  
**Order Number DM74ALS374ASJ**  
**NS Package Number M20D**

**Physical Dimensions** inches (millimeters) (Continued)

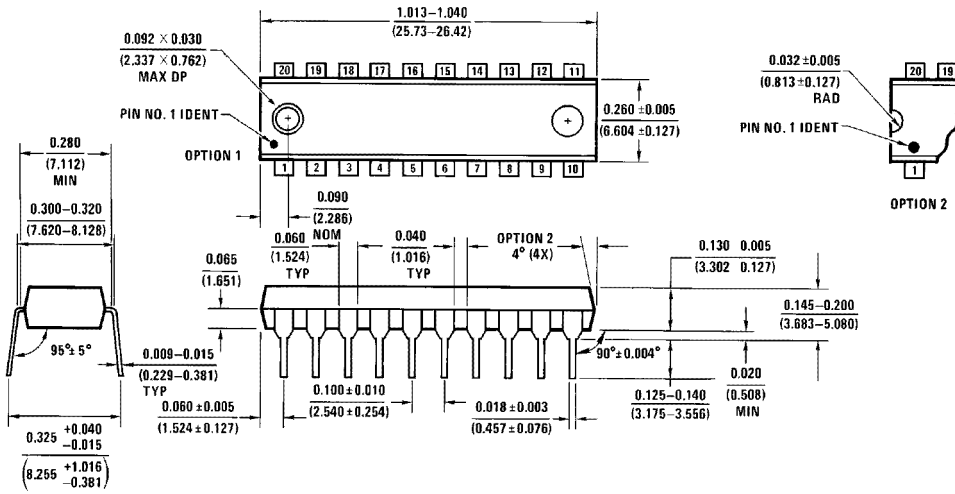

Molded Dual-In-Line Package (N)  
 Order Number DM64ALS374AN, DM74ALS374AN  
 NS Package Number N20A

N20A (REV G)

**LIFE SUPPORT POLICY**

NATIONAL'S PRODUCTS ARE NOT AUTHORIZED FOR USE AS CRITICAL COMPONENTS IN LIFE SUPPORT DEVICES OR SYSTEMS WITHOUT THE EXPRESS WRITTEN APPROVAL OF THE PRESIDENT OF NATIONAL SEMICONDUCTOR CORPORATION. As used herein:

1. Life support devices or systems are devices or systems which, (a) are intended for surgical implant into the body, or (b) support or sustain life, and whose failure to perform, when properly used in accordance with instructions for use provided in the labeling, can be reasonably expected to result in a significant injury to the user.
2. A critical component is any component of a life support device or system whose failure to perform can be reasonably expected to cause the failure of the life support device or system, or to affect its safety or effectiveness.



**National Semiconductor Corporation**  
 1111 West Bardin Road  
 Arlington, TX 76017  
 Tel: (800) 272-9959  
 Fax: (800) 737-7018

<http://www.national.com>

**National Semiconductor Europe**

Fax: +49 (0) 180-530 85 86  
 Email: [europe.support@nsc.com](mailto:europe.support@nsc.com)  
 Deutsch Tel: +49 (0) 180-530 85 85  
 English Tel: +49 (0) 180-532 78 32  
 Français Tel: +49 (0) 180-532 93 58  
 Italiano Tel: +49 (0) 180-534 16 80

**National Semiconductor Hong Kong Ltd.**

13th Floor, Straight Block,  
 Ocean Centre, 5 Canton Rd.  
 Tsimshatsui, Kowloon  
 Hong Kong  
 Tel: (852) 2737-1600  
 Fax: (852) 2736-9960

**National Semiconductor Japan Ltd.**

Tel: 81-043-299-2308  
 Fax: 81-043-299-2408