

MATING PLUG

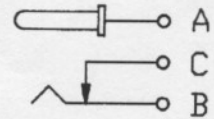

SCHEMATIC

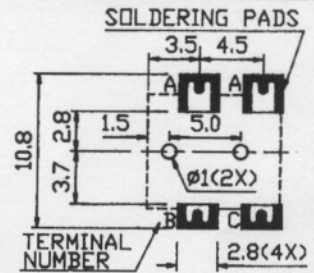

PCB LAYOUT

CENTER PIN DIAMETER  
 $\phi 1.0\text{MM}/\phi 1.3\text{MM}$

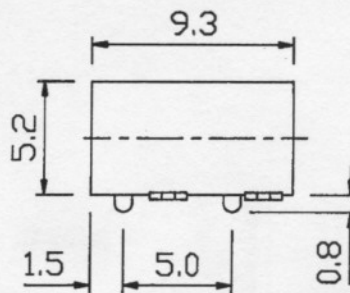
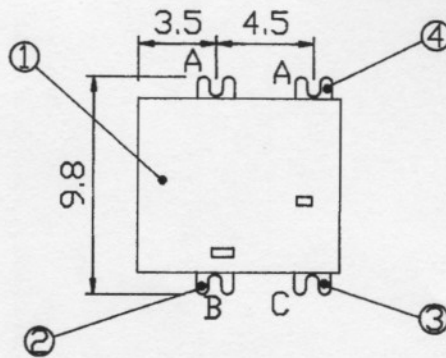
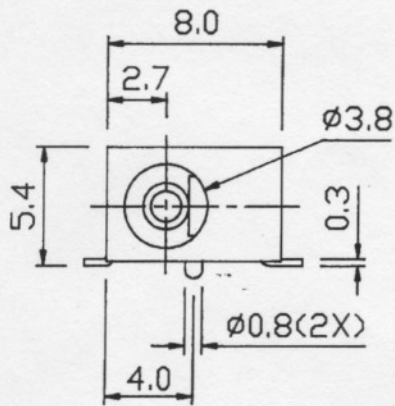

METAL TOL.:	$\pm 0.05$
PLASTIC TOL.:	$\pm 0.1$

5	CENTER PIN	BRASS	1	Ag PLATED					
3	CONTACT	BRASS	1	Ag PLATED	4	TERMINAL	BRASS	1	Ag PLATED
1	FRAME	NYLON 6T	1		2	SPRING	CuBe	1	Ag PLATED
NO	PART	MATERIAL	QTY	REMARKS	NO	PART	MATERIAL	QTY	REMARKS

ISSUED

SPECIFICATION

TITLE: DC POWER JACKS SMD

RATING: DC 30V 0.3A

MODEL NO: DCM-918

CONTACT RESISTANCE: 50m  $\Omega$  max.

INSULATION RESISTANCE: 100M  $\Omega$  AT 500V DC

UNIT: MM

DWN

WITHSTAND VOLTAGE: AC 500V for 1 minute

SCALE: 3:1

CHK'D

OPERATION FORCE: REFER ATTACH SPECIFICATION

TOLERANCE:  $\pm 0.2$

APP'D

SWITCHING LIFE: 5,000 cycles min.

DRWG NO:

BY:

SEE-PLUS INDUSTRIAL LTD



*Tia*  
*Sung*