



# 8-Bit, High-Speed, Multiplying D/A Converter (Universal Digital Logic Interface)

## DAC08

### FEATURES

- Fast Settling Output Current: 85 ns
- Full-Scale Current Prematched to  $\pm 1$  LSB
- Direct Interface to TTL, CMOS, ECL, HTL, PMOS
- Nonlinearity to 0.1% Maximum over Temperature Range
- High Output Impedance and Compliance: -10 V to +18 V
- Complementary Current Outputs
- Wide Range Multiplying Capability: 1 MHz Bandwidth
- Low FS Current Drift:  $\pm 10$  ppm/ $^{\circ}\text{C}$
- Wide Power Supply Range:  $\pm 4.5$  V to  $\pm 18$  V
- Low Power Consumption: 33 mW @  $\pm 5$  V
- Low Cost
- Available in Die Form

### GENERAL DESCRIPTION

The DAC08 series of 8-bit monolithic digital-to-analog converters provide very high-speed performance coupled with low cost and outstanding applications flexibility.

Advanced circuit design achieves 85 ns settling times with very low "glitch" energy and at low power consumption. Monotonic multiplying performance is attained over a wide 20-to-1 reference current range. Matching to within 1 LSB between reference and

full-scale currents eliminates the need for full-scale trimming in most applications. Direct interface to all popular logic families with full noise immunity is provided by the high swing, adjustable threshold logic input.

High voltage compliance complementary current outputs are provided, increasing versatility and enabling differential operation to effectively double the peak-to-peak output swing. In many applications, the outputs can be directly converted to voltage without the need for an external op amp.

All DAC08 series models guarantee full 8-bit monotonicity, and nonlinearities as tight as  $\pm 0.1\%$  over the entire operating temperature range are available. Device performance is essentially unchanged over the  $\pm 4.5$  V to  $\pm 18$  V power supply range, with 33 mW power consumption attainable at  $\pm 5$  V supplies.

The compact size and low power consumption make the DAC08 attractive for portable and military/aerospace applications; devices processed to MIL-STD-883, Level B are available.

DAC08 applications include 8-bit, 1  $\mu\text{s}$  A/D converters, servo motor and pen drivers, waveform generators, audio encoders and attenuators, analog meter drivers, programmable power supplies, CRT display drivers, high-speed modems and other applications where low cost, high speed and complete input/output versatility are required.

### FUNCTIONAL BLOCK DIAGRAM

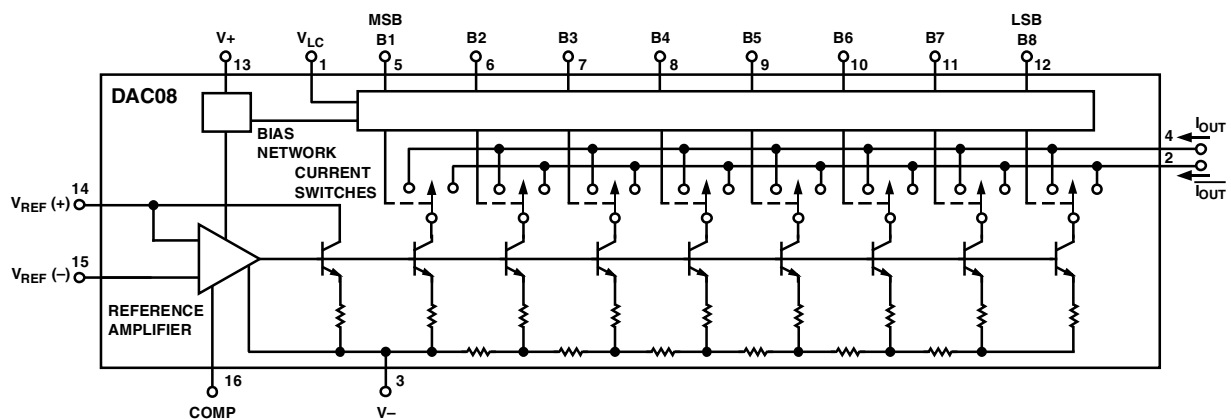

### REV. B

Information furnished by Analog Devices is believed to be accurate and reliable. However, no responsibility is assumed by Analog Devices for its use, nor for any infringements of patents or other rights of third parties that may result from its use. No license is granted by implication or otherwise under any patent or patent rights of Analog Devices.

One Technology Way, P.O. Box 9106, Norwood, MA 02062-9106, U.S.A.  
Tel: 781/329-4700  
Fax: 781/326-8703

www.analog.com

© Analog Devices, Inc., 2002

# DAC08—SPECIFICATIONS

## ELECTRICAL CHARACTERISTICS (@ $V_S = \pm 15\text{ V}$ , $I_{REF} = 2.0\text{ mA}$ , $-55^\circ\text{C} \leq T_A \leq +125^\circ\text{C}$ for DAC08/08A, $0^\circ\text{C} \leq T_A \leq +70^\circ\text{C}$ for DAC08E and DAC08H, $-40^\circ\text{C}$ to $+85^\circ\text{C}$ for DAC08C, unless otherwise noted. Output characteristics refer to both $I_{OUT}$ and $\overline{I_{OUT}}$ .)

Parameter	Symbol	Conditions	DAC08A/H			DAC08E			DAC08C			Unit
			Min	Typ	Max	Min	Typ	Max	Min	Typ	Max	
Resolution			8			8			8			Bits
Monotonicity			8			8			8			Bits
Nonlinearity	NL				$\pm 0.1$			$\pm 0.19$			$\pm 0.39$	% FS
Settling Time	$t_s$	$T_O \pm 1/2\text{ LSB}$ , All Bits Switched ON or OFF, $T_A = 25^\circ\text{C}^1$		85	135		85	150		85	150	ns
Propagation Delay												
Each Bit	$t_{PLH}$	$T_A = 25^\circ\text{C}^1$		35	60		35	60		35	60	ns
All Bits Switched	$t_{PHL}$			35	60		35	60		35	60	ns
Full-Scale Tempco <sup>1</sup>	$TCI_{FS}$	DAC08E		$\pm 10$	$\pm 50$		$\pm 10$	$\pm 80$ $\pm 50$		$\pm 10$	$\pm 80$	ppm/ $^\circ\text{C}$
Output Voltage Compliance (True Compliance)	$V_{OC}$	Full-Scale Current Change $< 1/2\text{ LSB}$ , $R_{OUT} > 20\text{ M}\Omega$ typ	-10		+18	-10		+18	-10		+18	V
Full Range Current	$I_{FR4}$	$V_{REF} = 10.000\text{ V}$ $R_{14}, R_{15} = 5.000\text{ k}\Omega$ $T_A = 25^\circ\text{C}$	1.984	1.992	2.000	1.94	1.99	2.04	1.94	1.99	2.04	mA
Full Range Symmetry	$I_{FRS}$	$I_{FR4} - I_{FR2}$		$\pm 0.5$	$\pm 4$		$\pm 1$	$\pm 8$		$\pm 2$	$\pm 16$	$\mu\text{A}$
Zero-Scale Current	$I_{ZS}$			0.1	1		0.2	2		0.2	4	$\mu\text{A}$
Output Current Range	$I_{OR1}$ $I_{OR2}$	$R_{14}, R_{15} = 5.000\text{ k}\Omega$ $V_{REF} = +15.0\text{ V}$ , $V_- = -10\text{ V}$ $V_{REF} = +25.0\text{ V}$ , $V_- = -12\text{ V}$ $I_{REF} = 2\text{ mA}$	2.1			2.1			2.1			mA
Output Current Noise				25			25			25		nA
Logic Input Levels					0.8			0.8			0.8	V
Logic Input "0"	$V_{IL}$	$V_{LC} = 0\text{ V}$										V
Logic Input "1"	$V_{IH}$		2			2			2			V
Logic Input Current												
Logic Input "0"	$I_{IL}$	$V_{IN} = -10\text{ V}$ to $+0.8\text{ V}$		-2	-10		-2	-10		-2	-10	$\mu\text{A}$
Logic Input "1"	$I_{IH}$	$V_{IN} = 2.0\text{ V}$ to $18\text{ V}$		0.002	10		0.002	10		0.002	10	$\mu\text{A}$
Logic Input Swing	$V_{IS}$	$V_- = -15\text{ V}$	-10		+18	-10		+18	-10		+18	V
Logic Threshold Range	$V_{THR}$	$V_S = \pm 15\text{ V}^1$	-10		+13.5	-10		+13.5	-10		+13.5	V
Reference Bias Current	$I_{15}$			-1	-3		-1	-3		-1	-3	$\mu\text{A}$
Reference Input Slew Rate	$dI/dt$	$R_{EQ} = 200\ \Omega$ $R_L = 100\ \Omega$ $C_C = 0\text{ pF}$ See Fast Pulsed Ref. Info Following. <sup>1</sup>	4	8		4	8		4	8		mA/ $\mu\text{s}$
Power Supply Sensitivity	$PSSI_{FS+}$ $PSSI_{FS-}$	$V_+ = 4.5\text{ V}$ to $18\text{ V}$ $V_- = -4.5\text{ V}$ to $-18\text{ V}$ $I_{REF} = 1.0\text{ mA}$		$\pm 0.0003$	$\pm 0.01$		$\pm 0.0003$	$\pm 0.01$		$\pm 0.0003$	$\pm 0.01$	$\% \Delta I_O / \% \Delta V_+$ $\% \Delta I_O / \% \Delta V_-$
Power Supply Current	$I_+$ $I_-$ $I_+$ $I_-$ $I_+$ $I_-$	$V_S = \pm 5\text{ V}$ , $I_{REF} = 1.0\text{ mA}$ $V_S = +5\text{ V}$ , $-15\text{ V}$ , $I_{REF} = 2.0\text{ mA}$ $V_S = \pm 15\text{ V}$ , $I_{REF} = 2.0\text{ mA}$	2.3	3.8		2.3	3.8		2.3	3.8		mA
				-4.3	-5.8		-4.3	-5.8		-4.3	-5.8	mA
				2.4	3.8		2.4	3.8		2.4	3.8	mA
				-6.4	-7.8		-6.4	-7.8		-6.4	-7.8	mA
				2.5	3.8		2.5	3.8		2.5	3.8	mA
				-6.5	-7.8		-6.5	-7.8		-6.5	-7.8	mA
Power Dissipation	$P_D$	$\pm 5\text{ V}$ , $I_{REF} = 1.0\text{ mA}$ $+5\text{ V}$ , $-15\text{ V}$ , $I_{REF} = 2.0\text{ mA}$ $\pm 15\text{ V}$ , $I_{REF} = 2.0\text{ mA}$	33	48		33	48		33	48		mW
				108	136		103	136		108	136	mW
				135	174		135	174		135	174	mW

### NOTES

<sup>1</sup>Guaranteed by design.

Specifications subject to change without notice.

**TYPICAL ELECTRICAL CHARACTERISTICS** (@  $V_S = \pm 15\text{ V}$ , and  $I_{REF} = 2.0\text{ mA}$ , unless otherwise noted. Output characteristics apply to both  $I_{OUT}$  and  $I_{OUT-}$ .)

Parameter	Symbol	Conditions	All Grades Typical	Unit
Reference Input Slew Rate	dI/dt		8	mA/ $\mu$ s
Propagation Delay	$t_{PLH}$ , $t_{PHL}$	$T_A = 25^\circ\text{C}$ , Any Bit	35	ns
Settling Time	$t_S$	To $\pm 1/2$ LSB, All Bits Switched ON or OFF, $T_A = 25^\circ\text{C}$	85	ns

Specifications subject to change without notice.

**ABSOLUTE MAXIMUM RATINGS<sup>1</sup>**

Operating Temperature	
DAC08AQ, Q	-55°C to +125°C
DAC08HQ, EQ, CQ, HP, EP	0°C to +70°C
DAC08CP, CS	-40°C to +85°C
Junction Temperature ( $T_J$ )	-65°C to +150°C
Storage Temperature Q Package	-65°C to +150°C
Storage Temperature P Package	-65°C to +125°C
Lead Temperature (Soldering, 60 sec)	300°C
V+ Supply to V- Supply	36 V
Logic Inputs	V- to V- plus 36 V
$V_{LC}$	V- to V+
Analog Current Outputs (at $V_S = 15\text{ V}$ )	4.25 mA
Reference Input ( $V_{14}$ to $V_{15}$ )	V- to V+
Reference Input Differential Voltage ( $V_{14}$ to $V_{15}$ )	$\pm 18\text{ V}$
Reference Input Current ( $I_{14}$ )	5.0 mA

Package Type	$\theta_{JA}$ <sup>2</sup>	$\theta_{JC}$	Unit
16-Lead Cerdip (Q)	100	16	°C/W
16-Lead Plastic DIP (P)	82	39	°C/W
20-Terminal LCC (RC)	76	36	°C/W
16-Lead SO (S)	111	35	°C/W

NOTES

<sup>1</sup>Absolute maximum ratings apply to both DICE and packaged parts, unless otherwise noted.  
<sup>2</sup> $\theta_{JA}$  is specified for worst-case mounting conditions, i.e.,  $\theta_{JA}$  is specified for device in socket for cerdip, Plastic DIP, and LCC packages;  $\theta_{JA}$  is specified for device soldered to printed circuit board for SO package.

**ORDERING GUIDE<sup>1</sup>**

Model	NL	Temperature Range	Package Description	Package Option	# Parts Per Container
DAC08AQ	$\pm 0.10\%$	-55°C to +125°C	Cerdip-16	Q-16	25
DAC08AQ <sup>2</sup> /883C	$\pm 0.10\%$	-55°C to +125°C	Cerdip-16	Q-16	25
DAC08HP	$\pm 0.10\%$	0°C to 70°C	P-DIP-16	N-16	25
DAC08HQ	$\pm 0.10\%$	0°C to 70°C	Cerdip-16	Q-16	25
DAC08Q	$\pm 0.19\%$	-55°C to +125°C	Cerdip-16	Q-16	25
DAC08Q <sup>2</sup> /883C	$\pm 0.19\%$	-55°C to +125°C	Cerdip-16	Q-16	25
DAC08RC/883C	$\pm 0.19\%$	-55°C to +125°C	LCC-20	E-20	55
DAC08EP	$\pm 0.19\%$	0°C to 70°C	P-DIP-16	N-16	25
DAC08EQ	$\pm 0.19\%$	0°C to 70°C	Cerdip-16	Q-16	25
DAC08ES	$\pm 0.19\%$	0°C to 70°C	SO-16	R-16A (Narrow Body)	47
DAC08ES-REEL	$\pm 0.19\%$	0°C to 70°C	SO-16	R-16A (Narrow Body)	2500
DAC08CP	$\pm 0.39\%$	-40°C to +85°C	P-DIP-16	N-16	25
DAC08CQ	$\pm 0.39\%$	0°C to 70°C	Cerdip-16	Q-16	25
DAC08CS	$\pm 0.39\%$	-40°C to +85°C	SO-16	R-16A (Narrow Body)	47
DAC08CS-REEL	$\pm 0.39\%$	-40°C to +85°C	SO-16	R-16A (Narrow Body)	2500
DAC08NBC	$\pm 0.10\%$	25°C	DICE		
DAC08GBC	$\pm 0.19\%$	25°C	DICE		
DAC08GRBC	$\pm 0.39\%$	25°C	DICE		

NOTES

<sup>1</sup>Devices processed in total compliance to MIL-STD-883. Consult factory for 883 data sheet.  
<sup>2</sup>For availability and burn-in information on SO and PLCC packages, contact your local sales office.  
 The DAC08 contains 84 transistors. Die size 63 mil x 87 mil = 5,481 square mils.

**CAUTION**

ESD (electrostatic discharge) sensitive device. Electrostatic charges as high as 4000 V readily accumulate on the human body and test equipment and can discharge without detection. Although the DAC08 features proprietary ESD protection circuitry, permanent damage may occur on devices subjected to high-energy electrostatic discharges. Therefore, proper ESD precautions are recommended to avoid performance degradation or loss of functionality.



# DAC08

## PIN CONNECTIONS

16-Lead Dual-In-Line Package  
(Q and P Suffix)

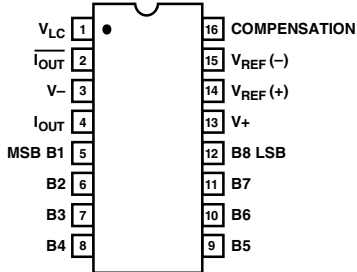

16-Lead SO  
(S Suffix)

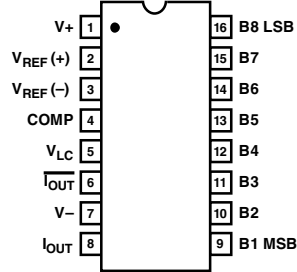

DAC08RC/883 20-Lead LCC  
(RC Suffix)

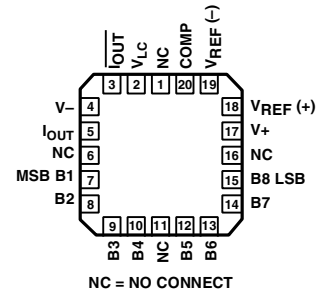

## DICE CHARACTERISTICS

(125°C Tested Dice Available)

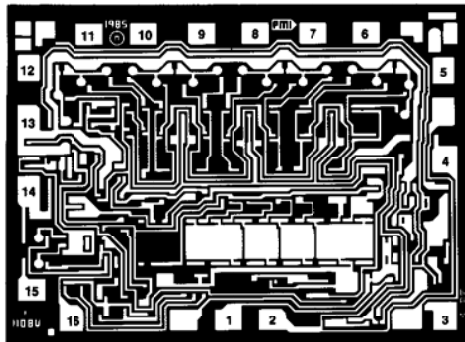

1. V<sub>LC</sub>
2. I<sub>OUT</sub>
3. V<sub>-</sub>
4. I<sub>OUT</sub>
5. BIT 1 (MSB)
6. BIT 2
7. BIT 3
8. BIT 4
9. BIT 5
10. BIT 6
11. BIT 7
12. BIT 8 (LSB)
13. V<sub>+</sub>
14. V<sub>REF</sub> (+)
15. V<sub>REF</sub> (-)
16. COMP

DIE SIZE 0.087 × 0.063 inch, 5,270 sq. mils  
(2.209 × 1.60 mm, 3.54 sq. mm)

**WAFER TEST LIMITS** (@  $V_S = \pm 15$  V,  $I_{REF} = 2.0$  mA;  $T_A = 25^\circ\text{C}$ , unless otherwise noted. Output characteristics apply to both  $I_{OUT}$  and  $I_{OUT-}$ )

Parameter	Symbol	Conditions	DAC08N Limit	DAC08G Limit	DAC08GR Limit	Unit
Resolution			8	8	8	Bits min
Monotonicity			8	8	8	Bits min
Nonlinearity	NL		$\pm 0.1$	$\pm 0.19$	$\pm 0.39$	% FS max
Output Voltage Compliance	$V_{OC}$	Full-Scale Current Change < 1/2 LSB	+18	+18	+18	V max
Full-Scale Current	$I_{FS4}$ or $I_{FS2}$	$V_{REF} = 10.000$ V $R_{14}, R_{15} = 5.000$ k $\Omega$	2.04	2.04	2.04	mA max
Full-Scale Symmetry	$I_{FSS}$		$\pm 8$	$\pm 8$	$\pm 16$	$\mu\text{A}$ max
Zero-Scale Current	$I_{ZS}$		2	4	4	$\mu\text{A}$ max
Output Current Range	$I_{FS1}$ or $I_{FS2}$	$V_- = -10$ V, $V_{REF} = +15$ V $V_- = -12$ V, $V_{REF} = +25$ V $R_{14}, R_{15} = 5.000$ k $\Omega$	2.1	2.1	2.1	mA min
Logic Input "0"	$V_{IL}$		0.8	0.8	0.8	V max
Logic Input "1"	$V_{IH}$		2	2	2	V min
Logic Input Current		$V_{LC} = 0$ V				
Logic "0"	$I_{IL}$	$V_{IN} = -10$ V to +0.8 V	$\pm 10$	$\pm 10$	$\pm 10$	$\mu\text{A}$ max
Logic "1"	$I_{IH}$	$V_{IN} = +2.0$ V to +18 V	$\pm 10$	$\pm 10$	$\pm 10$	$\mu\text{A}$ max
Logic Input Swing	$V_{IS}$	$V_- = -15$ V	+18	+18	+18	V max
Reference Bias Current	$I_{15}$		-10	-10	-10	V min
Power Supply Sensitivity	$PSSI_{FS+}$ $PSSI_{FS-}$	$V_+ = +4.5$ V to +18 V $V_- = -4.5$ V to -18 V $I_{REF} = 1.0$ mA	-3	-3	-3	$\mu\text{A}$ max
Power Supply Current	$I_+$	$V_S = \pm 15$ V $I_{REF} \leq 2.0$ mA	0.01	0.01	0.01	% FS/% V max
Power Dissipation	$P_D$	$V_S = \pm 15$ V $I_{REF} \leq 2.0$ mA	3.8	3.8	3.8	mA max
			-7.8	-7.8	-7.8	$\mu\text{A}$ max
			174	174	174	mW max

NOTE

Electrical tests are performed at wafer probe to the limits shown. Due to variations in assembly methods and normal yield loss, yield after packaging is not guaranteed for standard product dice. Consult factory to negotiate specifications based on dice lot qualification through sample lot assembly and testing.

# DAC08

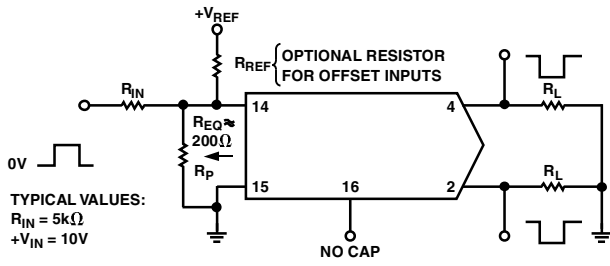

Figure 1. Pulsed Reference Operation

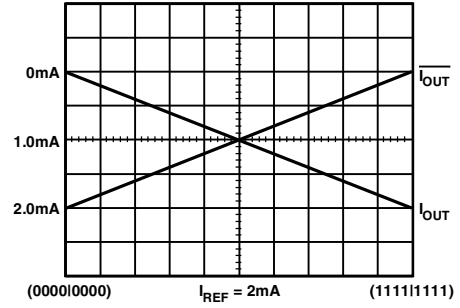

Figure 4. True and Complementary Output Operation

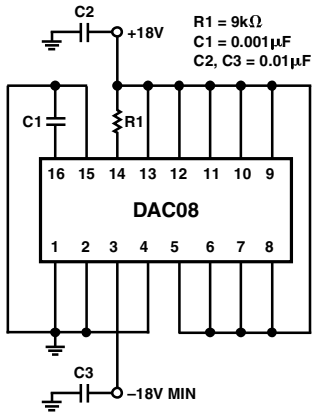

Figure 2. Burn-in Circuit

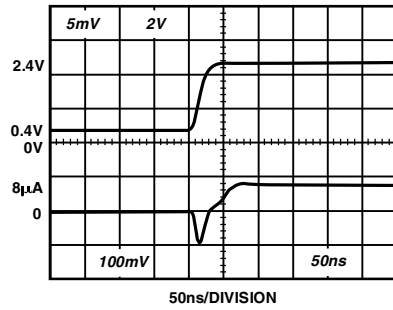

Figure 5. LSB Switching

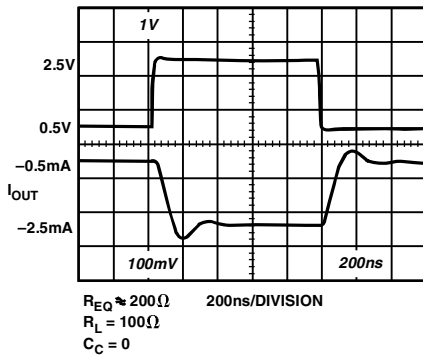

Figure 3. Fast Pulsed Reference Operation

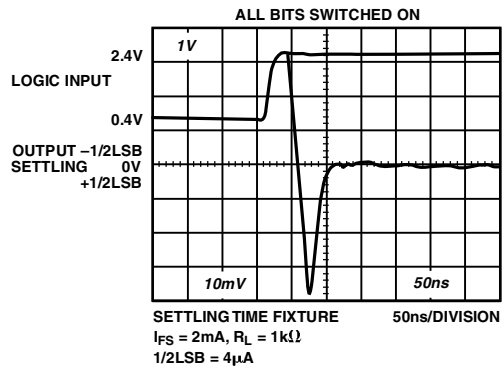
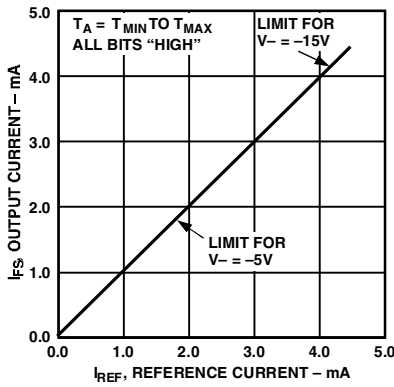
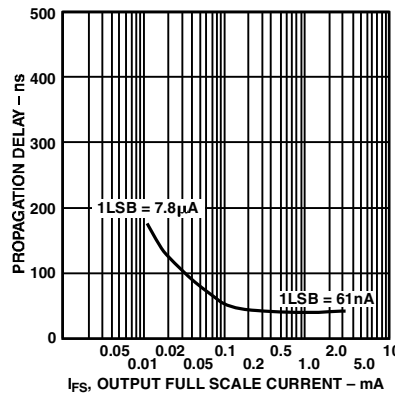

Figure 6. Full-Scale Settling Time

# Typical Performance Characteristics—DAC08



TPC 1. Full-Scale Current vs. Reference Current



TPC 2. LSB Propagation Delay vs.  $I_{FS}$

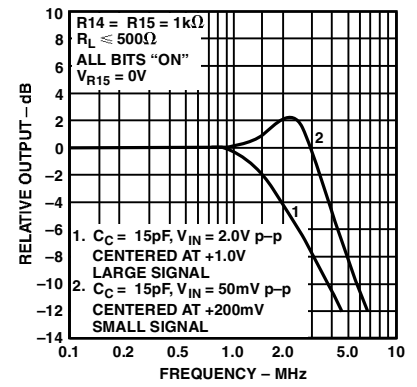

TPC 3. Reference Input Frequency Response

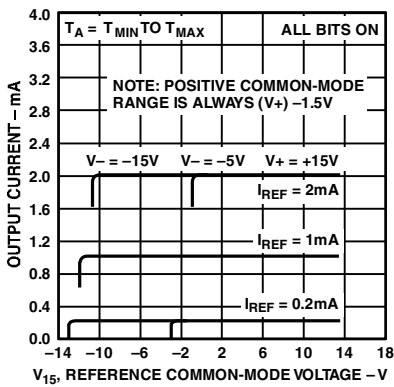

TPC 4. Reference Amp Common-Mode Range

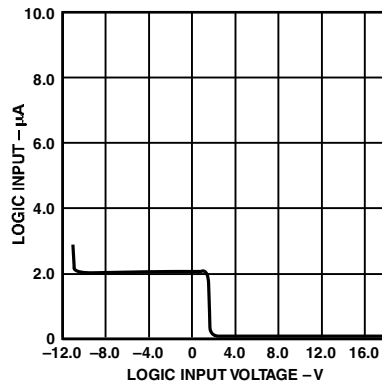

TPC 5. Logic Input Current vs. Input Voltage

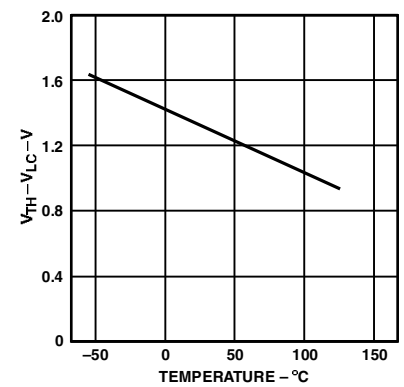

TPC 6.  $V_{TH} - V_{LC}$  vs. Temperature

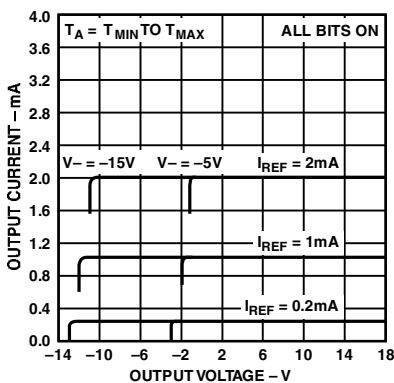

TPC 7. Output Current vs. Output Voltage (Output Voltage Compliance)

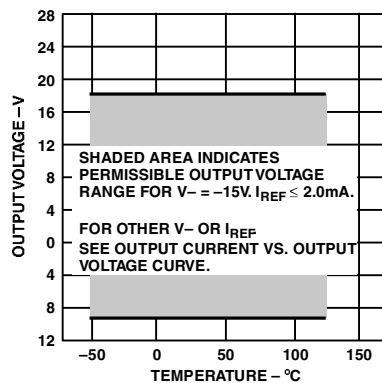

TPC 8. Output Voltage Compliance vs. Temperature

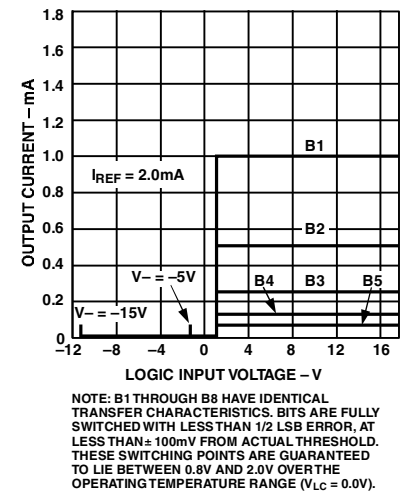

TPC 9. Bit Transfer Characteristics

# DAC08

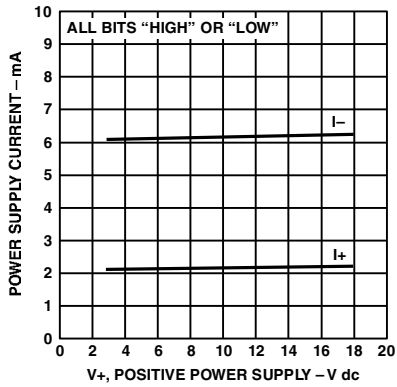

TPC 10. Power Supply Current vs.  $V_+$

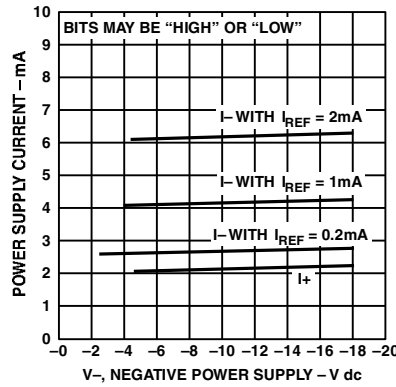

TPC 11. Power Supply Current vs.  $V_-$

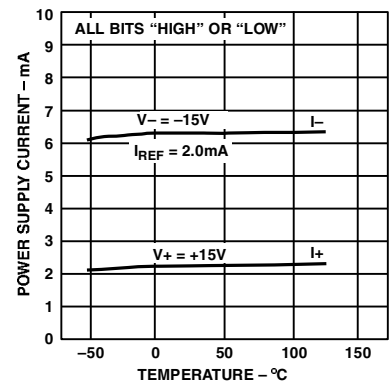

TPC 12. Power Supply Current vs. Temperature

## BASIC CONNECTIONS

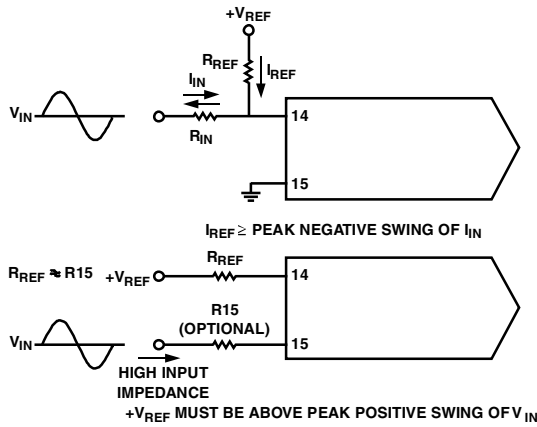

Figure 7. Accommodating Bipolar References

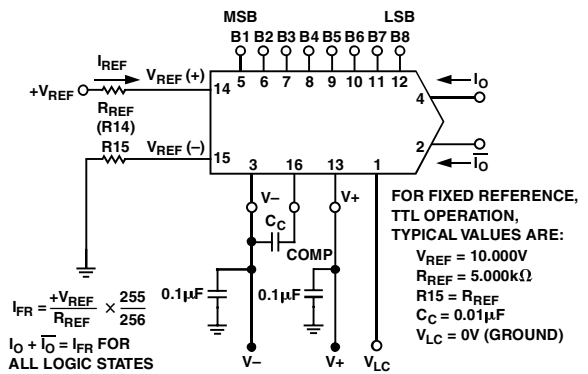

Figure 8. Basic Positive Reference Operation

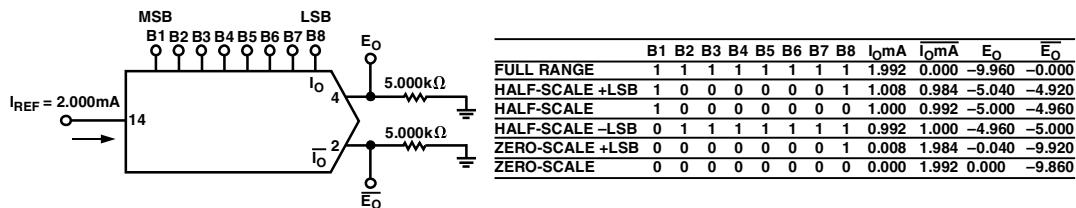

Figure 9. Basic Unipolar Negative Operation



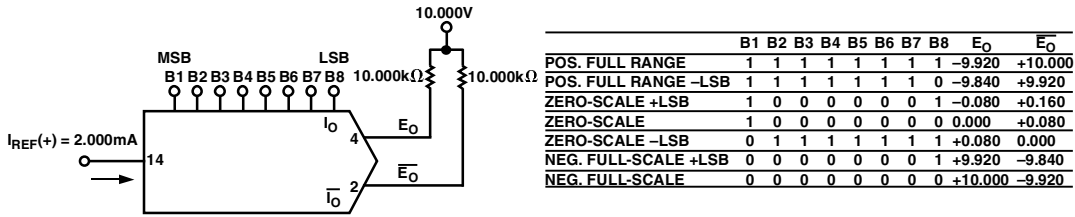

Figure 10. Basic Bipolar Output Operation

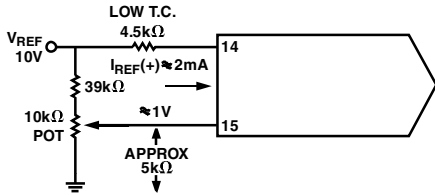

Figure 11. Recommended Full-Scale Adjustment Circuit

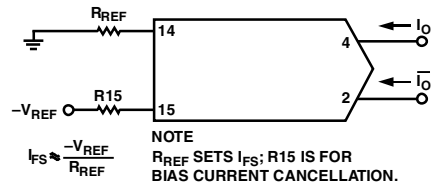
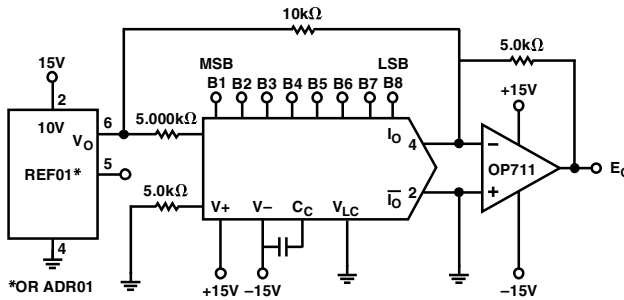
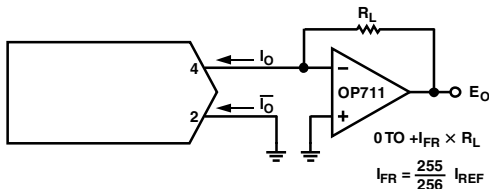

Figure 12. Basic Negative Reference Operation



	B1	B2	B3	B4	B5	B6	B7	B8	E <sub>o</sub>
POS. FULL RANGE	1	1	1	1	1	1	1	1	+4.960
ZERO-SCALE	1	0	0	0	0	0	0	0	0.000
NEG. FULL-SCALE +1 LSB	0	0	0	0	0	0	0	1	-4.960
NEG. FULL-SCALE	0	0	0	0	0	0	0	0	-5.000

Figure 13. Offset Binary Operation



FOR COMPLEMENTARY OUTPUT (OPERATION AS A NEGATIVE LOGIC DAC), CONNECT INVERTING INPUT OF OP AMP TO I<sub>o</sub> (PIN 2); CONNECT I<sub>o</sub> (PIN 4) TO GROUND.

Figure 14. Positive Low Impedance Output Operation

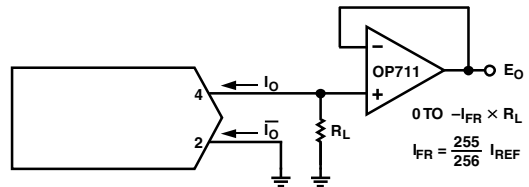

FOR COMPLEMENTARY OUTPUT (OPERATION AS A NEGATIVE LOGIC DAC), CONNECT NONINVERTING INPUT OF OP AMP TO I<sub>o</sub> (PIN 2); CONNECT I<sub>o</sub> (PIN 4) TO GROUND.

Figure 15. Negative Low Impedance Output Operation

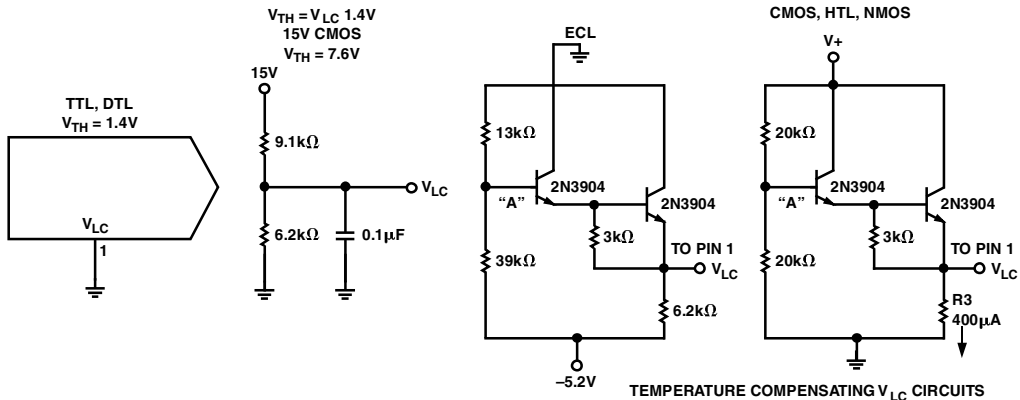

Figure 16. Interfacing with Various Logic Families

# DAC08

## APPLICATION INFORMATION REFERENCE AMPLIFIER SETUP

The DAC08 is a multiplying D/A converter in which the output current is the product of a digital number and the input reference current. The reference current may be fixed or may vary from nearly zero to 4.0 mA. The full-scale output current is a linear function of the reference current and is given by:

$$I_{FR} = \frac{255}{256} \times I_{REF}, \text{ where } I_{REF} = I_{14}$$

In positive reference applications, an external positive reference voltage forces current through R14 into the  $V_{REF(+)}$  terminal (Pin 14) of the reference amplifier. Alternatively, a negative reference may be applied to  $V_{REF(-)}$  at Pin 15; reference current flows from ground through R14 into  $V_{REF(+)}$  as in the positive reference case. This negative reference connection has the advantage of a very high impedance presented at Pin 15. The voltage at Pin 14 is equal to and tracks the voltage at Pin 15 due to the high gain of the internal reference amplifier. R15 (nominally equal to R14) is used to cancel bias current errors; R15 may be eliminated with only a minor increase in error.

Bipolar references may be accommodated by offsetting  $V_{REF}$  or Pin 15. The negative common-mode range of the reference amplifier is given by:  $V_{CM-} = V_-$  plus  $(I_{REF} \times 1 \text{ k}\Omega)$  plus 2.5 V. The positive common-mode range is  $V_+$  less 1.5 V.

When a dc reference is used, a reference bypass capacitor is recommended. A 5.0 V TTL logic supply is not recommended as a reference. If a regulated power supply is used as a reference, R14 should be split into two resistors with the junction bypassed to ground with a 0.1  $\mu\text{F}$  capacitor.

For most applications the tight relationship between  $I_{REF}$  and  $I_{FS}$  will eliminate the need for trimming  $I_{REF}$ . If required, full-scale trimming may be accomplished by adjusting the value of R14, or by using a potentiometer for R14. An improved method of full-scale trimming which eliminates potentiometer T.C. effects is shown in the recommended full-scale adjustment circuit.

Using lower values of reference current reduces negative power supply current and increases reference amplifier negative common-mode range. The recommended range for operation with a dc reference current is 0.2 mA to 4.0 mA.

## REFERENCE AMPLIFIER COMPENSATION FOR MULTIPLYING APPLICATIONS

AC reference applications will require the reference amplifier to be compensated using a capacitor from Pin 16 to  $V_-$ . The value of this capacitor depends on the impedance presented to Pin 14: for R14 values of 1.0, 2.5 and 5.0  $\text{k}\Omega$ , minimum values of  $C_C$  are 15, 37 and 75 pF. Larger values of R14 require proportionately increased values of  $C_C$  for proper phase margin, so the ratio of  $C_C$  (pF) to R14 ( $\text{k}\Omega$ ) = 15.

For fastest response to a pulse, low values of R14 enabling small  $C_C$  values should be used. If Pin 14 is driven by a high impedance such as a transistor current source, none of the above values will suffice and the amplifier must be heavily compensated which will decrease overall bandwidth and slew rate. For R14 = 1  $\text{k}\Omega$  and  $C_C$  = 15 pF, the reference amplifier slews at 4  $\text{mA}/\mu\text{s}$  enabling a transition from  $I_{REF} = 0$  to  $I_{REF} = 2 \text{ mA}$  in 500 ns.

Operation with pulse inputs to the reference amplifier may be accommodated by an alternate compensation scheme. This

technique provides lowest full-scale transition times. An internal clamp allows quick recovery of the reference amplifier from a cutoff ( $I_{REF} = 0$ ) condition. Full-scale transition (0 mA to 2 mA) occurs in 120 ns when the equivalent impedance at Pin 14 is 200  $\Omega$  and  $C_C = 0$ . This yields a reference slew rate of 16  $\text{mA}/\mu\text{s}$ , which is relatively independent of  $R_{IN}$  and  $V_{IN}$  values.

## LOGIC INPUTS

The DAC08 design incorporates a unique logic input circuit that enables direct interface to all popular logic families and provides maximum noise immunity. This feature is made possible by the large input swing capability, 2  $\mu\text{A}$  logic input current and completely adjustable logic threshold voltage. For  $V_- = -15 \text{ V}$ , the logic inputs may swing between  $-10 \text{ V}$  and  $+18 \text{ V}$ . This enables direct interface with 15 V CMOS logic, even when the DAC08 is powered from a 5 V supply. Minimum input logic swing and minimum logic threshold voltage are given by:  $V_-$  plus  $(I_{REF} \times 1 \text{ k}\Omega)$  plus 2.5 V. The logic threshold may be adjusted over a wide range by placing an appropriate voltage at the logic threshold control pin (Pin 1,  $V_{LC}$ ). The appropriate graph shows the relationship between  $V_{LC}$  and  $V_{TH}$  over the temperature range, with  $V_{TH}$  nominally 1.4 above  $V_{LC}$ . For TTL and DTL interface, simply ground pin 1. When interfacing ECL, an  $I_{REF} = 1 \text{ mA}$  is recommended. For interfacing other logic families, see preceding page. For general set-up of the logic control circuit, it should be noted that Pin 1 will source 100  $\mu\text{A}$  typical; external circuitry should be designed to accommodate this current.

Fastest settling times are obtained when Pin 1 sees a low impedance. If Pin 1 is connected to a 1  $\text{k}\Omega$  divider, for example, it should be bypassed to ground by a 0.01  $\mu\text{F}$  capacitor.

## ANALOG OUTPUT CURRENTS

Both true and complemented output sink currents are provided where  $I_O + I_{\bar{O}} = I_{FS}$ . Current appears at the "true" ( $I_O$ ) output when a "1" (logic high) is applied to each logic input. As the binary count increases, the sink current at pin 4 increases proportionally, in the fashion of a "positive logic" D/A converter. When a "0" is applied to any input bit, that current is turned off at Pin 4 and turned on at Pin 2. A decreasing logic count increases  $I_{\bar{O}}$  as in a negative or inverted logic D/A converter. Both outputs may be used simultaneously. If one of the outputs is not required, it must be connected to ground or to a point capable of sourcing  $I_{FS}$ ; do not leave an unused output pin open.

Both outputs have an extremely wide voltage compliance enabling fast direct current-to-voltage conversion through a resistor tied to ground or other voltage source. Positive compliance is 36 V above  $V_-$  and is independent of the positive supply. Negative compliance is given by  $V_-$  plus  $(I_{REF} \times 1 \text{ k}\Omega)$  plus 2.5 V.

The dual outputs enable double the usual peak-to-peak load swing when driving loads in quasi-differential fashion. This feature is especially useful in cable driving, CRT deflection and in other balanced applications such as driving center-tapped coils and transformers.

## POWER SUPPLIES

The DAC08 operates over a wide range of power supply voltages from a total supply of 9 V to 36 V. When operating at supplies of  $\pm 5 \text{ V}$  or less,  $I_{REF} \leq 1 \text{ mA}$  is recommended. Low reference current operation decreases power consumption and increases negative compliance, reference amplifier negative common-mode

range, negative logic input range and negative logic threshold range; consult the various figures for guidance. For example, operation at  $-4.5\text{ V}$  with  $I_{REF} = 2\text{ mA}$  is not recommended because negative output compliance would be reduced to near zero. Operation from lower supplies is possible; however, at least  $8\text{ V}$  total must be applied to ensure turn-on of the internal bias network.

Symmetrical supplies are not required, as the DAC08 is quite insensitive to variations in supply voltage. Battery operation is feasible as no ground connection is required; however, an artificial ground may be used to ensure logic swings, etc., remain between acceptable limits.

Power consumption may be calculated as follows:

$$P_D = (I_+) (V_+) + (I_-) (V_-)$$

A useful feature of the DAC08 design is that supply current is constant and independent of input logic states; this is useful in cryptographic applications and further serves to reduce the size of the power supply bypass capacitors.

### TEMPERATURE PERFORMANCE

The nonlinearity and monotonicity specifications of the DAC08 are guaranteed to apply over the entire rated operating temperature range. Full-scale output current drift is low, typically  $\pm 10\text{ ppm}/^\circ\text{C}$ , with zero-scale output current and drift essentially negligible compared to  $1/2\text{ LSB}$ .

The temperature coefficient of the reference resistor R14 should match and track that of the output resistor for minimum overall full-scale drift. Settling times of the DAC08 decrease approximately  $10\%$  at  $-55^\circ\text{C}$ ; at  $+125^\circ\text{C}$  an increase of about  $15\%$  is typical.

The reference amplifier must be compensated by using a capacitor from pin 16 to  $V_-$ . For fixed reference operation, a  $0.01\text{ }\mu\text{F}$  capacitor is recommended. For variable reference applications, see “Reference Amplifier Compensation for Multiplying Applications” section.

### MULTIPLYING OPERATION

The DAC08 provides excellent multiplying performance with an extremely linear relationship between  $I_{FS}$  and  $I_{REF}$  over a range of  $4\text{ }\mu\text{A}$  to  $4\text{ mA}$ . Monotonic operation is maintained over a typical range of  $I_{REF}$  from  $100\text{ }\mu\text{A}$  to  $4.0\text{ mA}$ .

### SETTLING TIME

The DAC08 is capable of extremely fast settling times, typically  $85\text{ ns}$  at  $I_{REF} = 2.0\text{ mA}$ . Judicious circuit design and careful board layout must be employed to obtain full performance potential during testing and application. The logic switch design enables propagation delays of only  $35\text{ ns}$  for each of the 8 bits. Settling time to within  $1/2\text{ LSB}$  of the LSB is therefore  $35\text{ ns}$ , with each progressively larger bit taking successively longer. The MSB settles in  $85\text{ ns}$ , thus determining the overall settling time of  $85\text{ ns}$ . Settling to 6-bit accuracy requires about  $65\text{ ns}$  to  $70\text{ ns}$ . The output capacitance of the DAC08 including the package is approximately  $15\text{ pF}$ , therefore the output RC time constant dominates settling time if  $R_L > 500\text{ }\Omega$ .

Settling time and propagation delay are relatively insensitive to logic input amplitude and rise and fall times, due to the high gain of the logic switches. Settling time also remains essentially constant for  $I_{REF}$  values. The principal advantage of higher  $I_{REF}$  values lies in the ability to attain a given output level with lower load resistors, thus reducing the output RC time constant.

Measurement of settling time requires the ability to accurately resolve  $\pm 4\text{ }\mu\text{A}$ , therefore a  $1\text{ k}\Omega$  load is needed to provide adequate drive for most oscilloscopes. The settling time fixture shown in schematic labelled “Settling Time Measurement” uses a cascade design to permit driving a  $1\text{ k}\Omega$  load with less than  $5\text{ pF}$  of parasitic capacitance at the measurement node. At  $I_{REF}$  values of less than  $1.0\text{ mA}$ , excessive RC damping of the output is difficult to prevent while maintaining adequate sensitivity. However, the major carry from  $01111111$  to  $10000000$  provides an accurate indicator of settling time. This code change does not require the normal 6.2 time constants to settle to within  $\pm 0.2\%$  of the final value, and thus settling times may be observed at lower values of  $I_{REF}$ .

DAC08 switching transients or “glitches” are very low and may be further reduced by small capacitive loads at the output at a minor sacrifice in settling time.

Fastest operation can be obtained by using short leads, minimizing output capacitance and load resistor values, and by adequate bypassing at the supply, reference, and  $V_{LC}$  terminals. Supplies do not require large electrolytic bypass capacitors as the supply current drain is independent of input logic states;  $0.1\text{ }\mu\text{F}$  capacitors at the supply pins provide full transient protection.

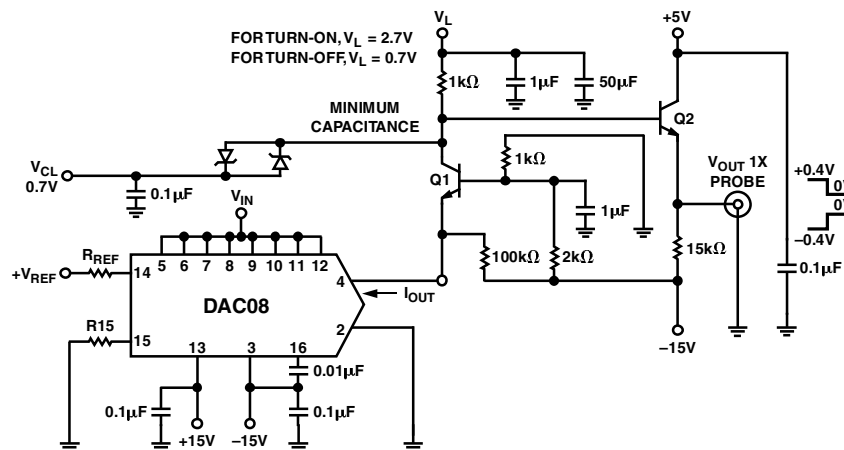

Figure 17. Settling Time Measurement

# DAC08

## OUTLINE DIMENSIONS

Dimensions shown in inches and (mm).

16-Lead Plastic DIP (N-16)

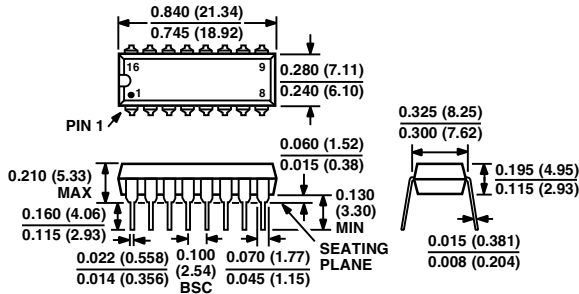

16-Lead Cerdip (Q-16)

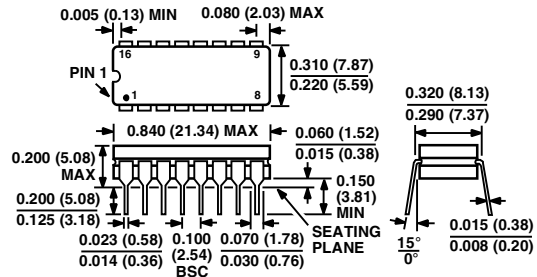

16-Lead SO (R-16A)

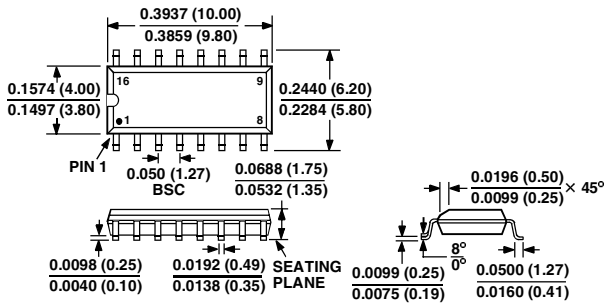

20-Terminal Leadless Chip Carrier (E-20)

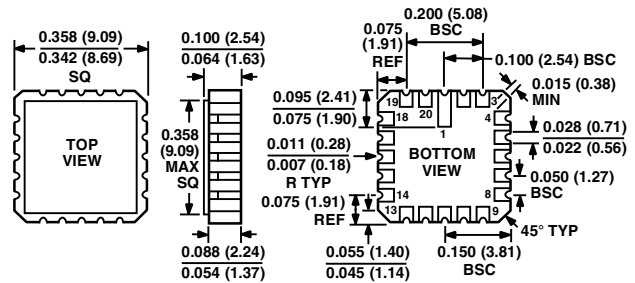

## Revision History

Location	Page
Data Sheet changed from REV. A to REV. B.	
Edits to SPECIFICATIONS .....	2
Edits to ABSOLUTE MAXIMUM RATINGS .....	3
Edits to ORDERING GUIDE .....	3
Edits to WAFER TEST LIMITS .....	5
Edit to Figure 13 .....	8
Edits to Figures 14 and 15 .....	9
Replacement of SO-16 with R-16A Package Outline .....	12