



D8748H/D8749H HMOS-E SINGLE-COMPONENT 8-BIT MICROCONTROLLER

- High Performance HMOS-E
- Interval Timer/Event Counter
- Two Single Level Interrupts
- Single 5-Volt Supply
- Over 96 Instructions; 90% Single Byte
- Compatible with 8080/8085 Peripherals
- Easily Expandable Memory and I/O
- Up to 1.35 μ s Instruction Cycle; All Instructions 1 or 2 Cycles

The Intel D8749H/D8748H are totally self-sufficient, 8-bit parallel computers fabricated on single silicon chips using Intel's advanced N-channel silicon gate HMOS-E process.

The family contains 27 I/O lines, an 8-bit timer/counter, on-chip RAM and on-board oscillator/clock circuits. For systems that require extra capability, the family can be expanded using MCS[®]-80/MCS[®]-85 peripherals.

These microcomputers are designed to be efficient controllers as well as arithmetic processors. They have extensive bit handling capability as well as facilities for both binary and BCD arithmetic. Efficient use of program memory results from an instruction set consisting mostly of single byte instructions and no instructions over 2 bytes in length.

Device	Internal Memory	
D8749H	2K x 8 EPROM	128 x 8 RAM
D8748H	1K x 8 EPROM	64 x 8 RAM

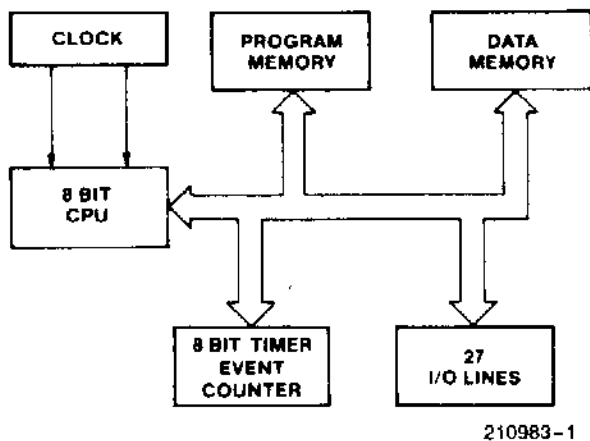

Figure 1.
Block Diagram

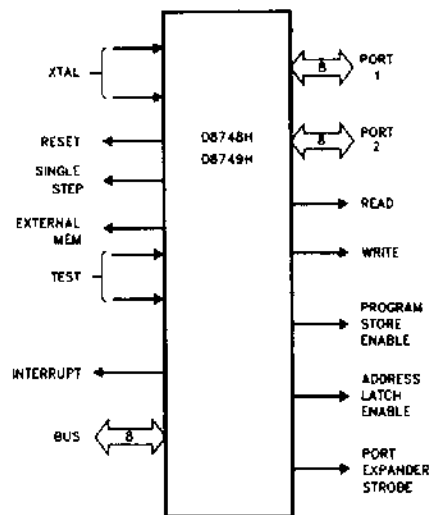

Figure 2.
Logic Symbol

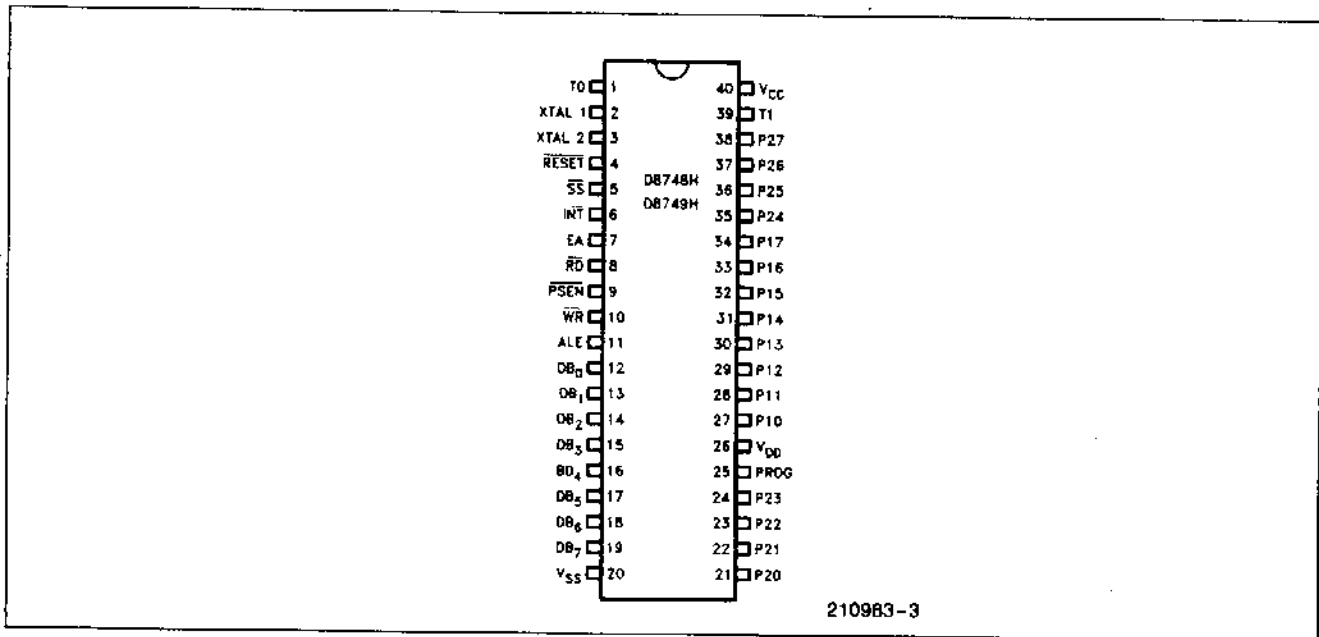

Figure 3. Pin Configuration

Table 1. Pin Description (40-Pin DIP)

Symbol	Pin No.	Function
V _{SS}	20	Circuit GND potential.
V _{DD}	26	+ 5V during normal operation.
		Programming power supply (+ 21V).
V _{CC}	40	Main power supply; + 5V during operation and programming.
PROG	25	Output strobe for 8243 I/O expander.
		Program pulse (+ 18V) input pin during programming.
P10-P17 Port 1	27-34	8-bit quasi-bidirectional port.
P20-P23	21-24	8-bit quasi-bidirectional port. P20-P23 contain the four high order program counter bits during an external program memory fetch and serve as a 4-bit I/O expander bus for 8243.
P24-P27 Port 2	35-38	
DB0-DB7 BUS	12-19	True bidirectional port which can be written or read synchronously using the RD, WR strobes. The port can also be statically latched. Contains the 8 low order program counter bits during an external program memory fetch, and receives the addressed instruction under the control of PSEN. Also contains the address and data during an external RAM data store instruction, under control of ALE, RD, and WR.
T0	1	Input pin testable using the conditional transfer instructions JT0 and JNT0. T0 can be designated as a clock output using ENT0 CKL instruction. Used during programming.
T1	39	Input pin testable using the JT1, and JNT1 instructions. Can be designated the timer/counter input using the STRT CNT instruction.
INT	6	Interrupt input. Initiates an interrupt if interrupt is enabled. Interrupt is disabled after a reset. Also testable with conditional jump instruction. (Active low) interrupt must remain low for at least 3 machine cycles for proper operation.
RD	8	Output strobe activated during a BUS read. Can be used to enable data onto the bus from an external device. Used as a read strobe to external data memory. (Active low)

1

Table 1. Pin Description (40-Pin DIP) (Continued)

Symbol	Pin No.	Function
RESET	4	Input which is used to initialize the processor. (Active low) (Non TTL V_{IH}) Used during programming.
\overline{WR}	10	Output strobe during a bus write. (Active low) Used as write strobe to external data memory.
ALE	11	Address latch enable. This signal occurs once during each cycle and is useful as a clock output. The negative edge of ALE strobes address into external data and program memory.
\overline{PSEN}	9	Program store enable. This output occurs only during a fetch to external program memory. (Active low.)
\overline{SS}	5	Single step input can be used in conjunction with ALE to "single step" the processor through each instruction.
EA	7	External access input which forces all program memory fetches to reference external memory. Useful for emulation and debug. (Active high.) Used during (18V) programming.
XTAL1	2	One side of crystal input for internal oscillator. Also input for external source. (Non TTL V_{IH} .)
XTAL2	3	Other side of crystal input.

Table 2. Instruction Set

Mnemonic	Description	Bytes	Cycles	Mnemonic	Description	Bytes	Cycles
ACCUMULATOR				ACCUMULATOR (Continued)			
ADD A, R	Add register to A	1	1	INC A	Increment A	1	1
ADD A, @R	Add data memory to A	1	1	DEC A	Decrement A	1	1
ADD A, # data	Add immediate to A	2	2	CLR A	Clear A	1	1
ADDC A, R	Add register with carry	1	1	CPL A	Complement A	1	1
ADDC A, @R	Add data memory with carry	1	1	DA A	Decimal adjust A	1	1
ADDC A, # data	Add immediate with carry	2	2	SWAP A	Swap nibbles of A	1	1
ANL A, R	And register to A	1	1	RL A	Rotate A left	1	1
ANL A, @R	And data memory to A	1	1	RLC A	Rotate A left through carry	1	1
ANL A, # data	And immediate to A	2	2	RR A	Rotate A right	1	1
ORL A, R	Or register to A	1	1	RRC A	Rotate A right through carry	1	1
ORL A, @R	Or data memory to A	1	1	INPUT/OUTPUT			
ORL A, # data	Or immediate to A	2	2	IN A, P	Input port to A	1	2
XRL A, R	Exclusive or register to A	1	1	OUTL P, A	Output A to port	1	2
XRL A, @R	Exclusive or data memory to A	1	1	ANL P, # data	And immediate to port	2	2
XRL A, # data	Exclusive or immediate to A	2	2	ORL P, # data	Or immediate to port	2	2
				INS A, BUS	Input BUS to A	1	2
				OUTL BUS, A	Output A to BUS	1	2
				ANL BUS, # data	And immediate to BUS	2	2
				ORL BUS, # data	Or immediate to BUS	2	2
				MOVD A, P	Input expander port to A	1	2

Table 2. Instruction Set (Continued)

Mnemonic	Description	Bytes	Cycles	Mnemonic	Description	Bytes	Cycles
INPUT/OUTPUT (Continued)				DATA MOVES (Continued)			
MOVD P, A	Output A to expander port	1	2	MOV R, A	Move A to register	1	1
ANLD P, A	And A to expander port	1	2	MOV @R, A	Move A to data memory	1	1
ORLD P, A	Or A to expander port	1	2	MOV R, #data	Move immediate to register	2	2
REGISTERS				MOV @R, #data	Move immediate to data memory	2	2
INCR	Increment register	1	1	MOV A, PSW	Move PSW to A	1	1
INC @R	Increment data memory	1	1	MOV PSW, A	Move A to PSW	1	1
DEC R	Decrement register	1	1	XCH A, R	Exchange A and register	1	1
BRANCH				XCH A, @R	Exchange A and data memory	1	1
JMP addr	Jump unconditional	2	2	XCHD A, @R	Exchange nibble of A and register	1	1
JMPP @A	Jump indirect	1	2	MOVX A, @R	Move external data memory to A	1	2
DJNZ R, addr	Decrement register and skip	2	2	MOVX @R, A	Move A to external data memory	1	2
JC addr	Jump on carry = 1	2	2	MOVP A, @A	Move to A from current page	1	2
JNC addr	Jump on carry = 0	2	2	MOVPS A, @A	Move to A from page 3	1	2
JZ addr	Jump on A zero	2	2	TIMER/COUNTER			
JNZ addr	Jump on A not zero	2	2	MOV A, T	Read timer/counter	1	1
JT0 addr	Jump on T0 = 1	2	2	MOV T, A	Load timer/counter	1	1
JNT0 addr	Jump on T0 = 0	2	2	STRT T	Start timer	1	1
JT1 addr	Jump on T1 = 1	2	2	STRT CNT	Start counter	1	1
JNT1 addr	Jump on T1 = 0	2	2	STOP TCNT	Stop timer/counter	1	1
JF0 addr	Jump on F0 = 1	2	2	EN TCNTI	Enable timer/counter interrupt	1	1
JF1 addr	Jump on F1 = 1	2	2	DIS TCNTI	Disable timer/counter interrupt	1	1
JTF addr	Jump on timer flag	2	2	CONTROL			
JNI addr	Jump on INT = 0	2	2	EN I	Enable external interrupt	1	1
JBb addr	Jump on accumulator bit	2	2	DIS I	Disable external interrupt	1	1
SUBROUTINE				SEL RB0	Select register bank 0	1	1
CALL addr	Jump to subroutine	2	2	SEL RB1	Select register bank 1	1	1
RET	Return	1	2	SEL MB0	Select memory bank 0	1	1
RETR	Return and restore status	1	2	SEL MB1	Select memory bank 1	1	1
FLAGS				ENT0 CLK	Enable clock output on T0	1	1
CLR C	Clear carry	1	1	NOP	No operation	1	1
CPL C	Complement carry	1	1				
CLR F0	Clear flag 0	1	1				
CPL F0	Complement flag 0	1	1				
CLR F1	Clear flag 1	1	1				
CPL F1	Complement flag 1	1	1				
DATA MOVES							
MOV A, R	Move register to A	1	1				
MOV A, @R	Move data memory to A	1	1				
MOV A, #data	Move immediate to A	2	2				

1

ABSOLUTE MAXIMUM RATINGS*

Ambient Temperature Under Bias 0°C to +70°C
 Storage Temperature -65°C to +150°C
 Voltage On Any Pin With Respect
 to Ground -0.5V to +7V
 Power Dissipation 1.0 Watt

NOTICE: This is a production data sheet. The specifications are subject to change without notice.

*WARNING: Stressing the device beyond the "Absolute Maximum Ratings" may cause permanent damage. These are stress ratings only. Operation beyond the "Operating Conditions" is not recommended and extended exposure beyond the "Operating Conditions" may affect device reliability.

DC CHARACTERISTICS $T_A = 0^\circ\text{C to } +70^\circ\text{C}; V_{CC} = V_{DD} = 5V \pm 10\%; V_{SS} = 0V$

Symbol	Parameter	Limits			Unit	Test Conditions	Device
		Min	Typ	Max			
V_{IL}	Input Low Voltage (All Except RESET, X1, X2)	-0.5		0.8	V		All
V_{IL1}	Input Low Voltage (RESET, X1, X2)	-0.5		0.6	V		All
V_{IH}	Input High Voltage (All Except XTAL1, XTAL2, RESET)	2.0		V_{CC}	V		All
V_{IH1}	Input High Voltage (X1, X2, RESET)	3.8		V_{CC}	V		All
V_{OL}	Output Low Voltage (BUS)			0.45	V	$I_{OL} = 2.0 \text{ mA}$	All
V_{OL1}	Output Low Voltage (RD, WR, PSEN, ALE)			0.45	V	$I_{OL} = 1.8 \text{ mA}$	All
V_{OL2}	Output Low Voltage (PROG)			0.45	V	$I_{OL} = 1.0 \text{ mA}$	All
V_{OL3}	Output Low Voltage (All Other Outputs)			0.45	V	$I_{OL} = 1.6 \text{ mA}$	All
V_{OH}	Output High Voltage (BUS)	2.4			V	$I_{OH} = -400 \mu\text{A}$	All
V_{OH1}	Output High Voltage (RD, WR, PSEN, ALE)	2.4			V	$I_{OH} = -100 \mu\text{A}$	All
V_{OH2}	Output High Voltage (All Other Outputs)	2.4			V	$I_{OH} = -40 \mu\text{A}$	All
I_{L1}	Leakage Current (T1, INT)			± 10	μA	$V_{SS} \leq V_{IN} \leq V_{CC}$	All
I_{L11}	Input Leakage Current (P10-P17, P20-P27, EA, SS)			-500	μA	$V_{SS} + 0.45 \leq V_{IN} \leq V_{CC}$	All
I_{L12}	Input Leakage Current RESET	-10		-300	μA	$V_{SS} \leq V_{IN} \leq 3.8V$	All
I_{L0}	Leakage Current (BUS, T0) (High Impedance State)			± 10	μA	$V_{SS} \leq V_{IN} \leq V_{CC}$	All
$I_{DD} + I_{CC}$	Total Supply Current*		80	100	mA		8748H
			95	110	mA		8749H

NOTE:

* $I_{CC} + I_{DD}$ is measured with all outputs disconnected; \overline{SS} , \overline{RESET} , and \overline{INT} equal to V_{CC} ; EA equal to V_{SS} .

AC CHARACTERISTICS $T_A = 0^\circ\text{C to } +70^\circ\text{C}; V_{CC} = V_{DD} = 5V \pm 10\%; V_{SS} = 0V$

Symbol	Parameter	f(t) (Note 3)	11 MHz		Unit	Conditions (Note 1)
			Min	Max		
t	Clock Period	1/xtal freq	90.9	1000	ns	(Note 3)
t _{LL}	ALE Pulse Width	3.5t - 170	150		ns	
t _{AL}	Addr Setup to ALE	2t - 110	70		ns	(Note 2)
t _{LA}	Addr Hold from ALE	t - 40	50		ns	
t _{CC1}	Control Pulse Width (\overline{RD} , \overline{WR})	7.5t - 200	480		ns	
t _{CC2}	Control Pulse Width (\overline{PSEN})	6t - 200	350		ns	
t _{DW}	Data Setup before \overline{WR}	6.5t - 200	390		ns	
t _{WD}	Data Hold after \overline{WR}	t - 50	40		ns	
t _{DR}	Data Hold (\overline{RD} , \overline{PSEN})	1.5t - 30	0	110	ns	
t _{RD1}	\overline{RD} to Data In	6t - 170		375	ns	
t _{RD2}	\overline{PSEN} to Data In	4.5t - 170		240	ns	
t _{AW}	Addr Setup to \overline{WR}	5t - 150	300		ns	
t _{AD1}	Addr Setup to Data (\overline{RD})	10.5t - 220		730	ns	
t _{AD2}	Addr Setup to Data (\overline{PSEN})	7.5t - 200		460	ns	
t _{AFC1}	Addr Float to \overline{RD} , \overline{WR}	2t - 40	140		ns	(Note 2)
t _{AFC2}	Addr Float to \overline{PSEN}	0.5t - 40	10		ns	(Note 2)
t _{LAFC1}	ALE to Control (\overline{RD} , \overline{WR})	3t - 75	200		ns	
t _{LAFC2}	ALE to Control (\overline{PSEN})	1.5t - 75	60		ns	
t _{CA1}	Control to ALE (\overline{RD} , \overline{WR} , PROG)	t - 65	25		ns	
t _{CA2}	Control to ALE (\overline{PSEN})	4t - 70	290		ns	
t _{CP}	Port Control Setup to PROG	1.5t - 80	50		ns	
t _{PC}	Port Control Hold to PROG	4t - 260	100		ns	
t _{PR}	PROG to P2 Input Valid	8.5t - 120		650	ns	
t _{PF}	Input Data Hold from PROG	1.5t	0	140	ns	
t _{DP}	Output Data Setup	6t - 290	250		ns	
t _{PD}	Output Data Hold	1.5t - 90	40		ns	
t _{PP}	PROG Pulse Width	10.5t - 250	700		ns	
t _{PL}	Port 2 I/O Setup to ALE	4t - 200	160		ns	
t _{LP}	Port 2 I/O Hold to ALE	0.5t - 30	15		ns	
t _{PV}	Port Output from ALE	4.5t + 100		510	ns	
t _{OPRR}	T0 Rep Rate	3t	270		ns	
t _{CY}	Cycle Time	15t	1.36	15.0	μs	

NOTES:

- Control outputs CL = 80 pF; BUS outputs CL = 150 pF.
- BUS High Impedance Load 20 pF.
- f(t) assumes 50% duty cycle on X1, X2. Max clock period is for a 1 MHz crystal input.

WAVEFORMS

INSTRUCTION FETCH FROM PROGRAM MEMORY

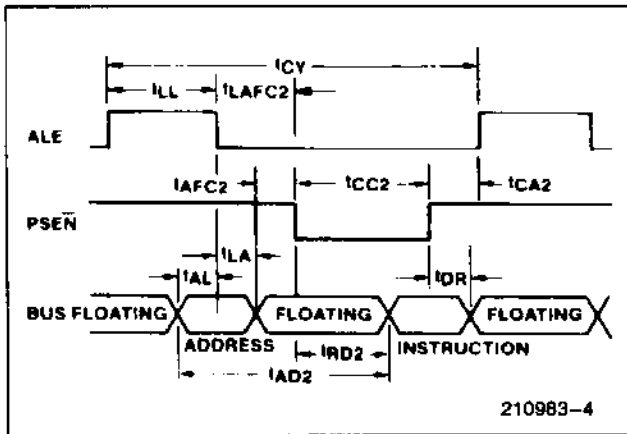

WRITE TO EXTERNAL DATA MEMORY

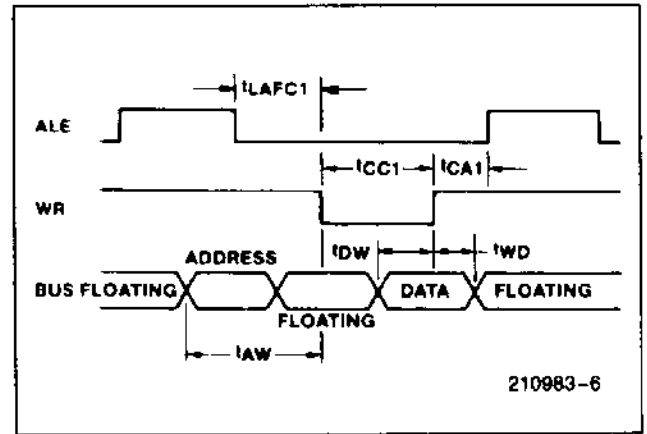

READ FROM EXTERNAL DATA MEMORY

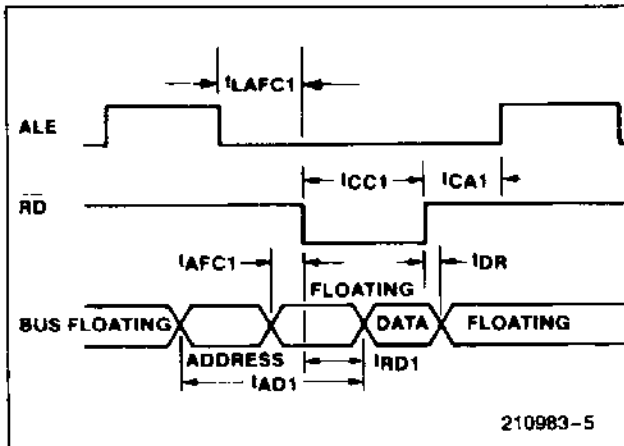

INPUT AND OUTPUT FOR AC TESTS

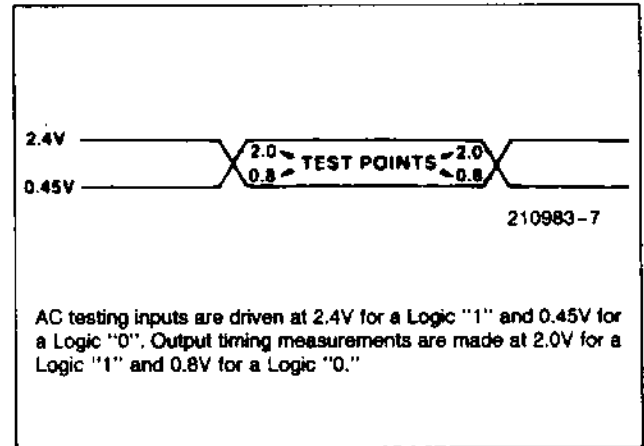

PORT 1/PORT 2 TIMING

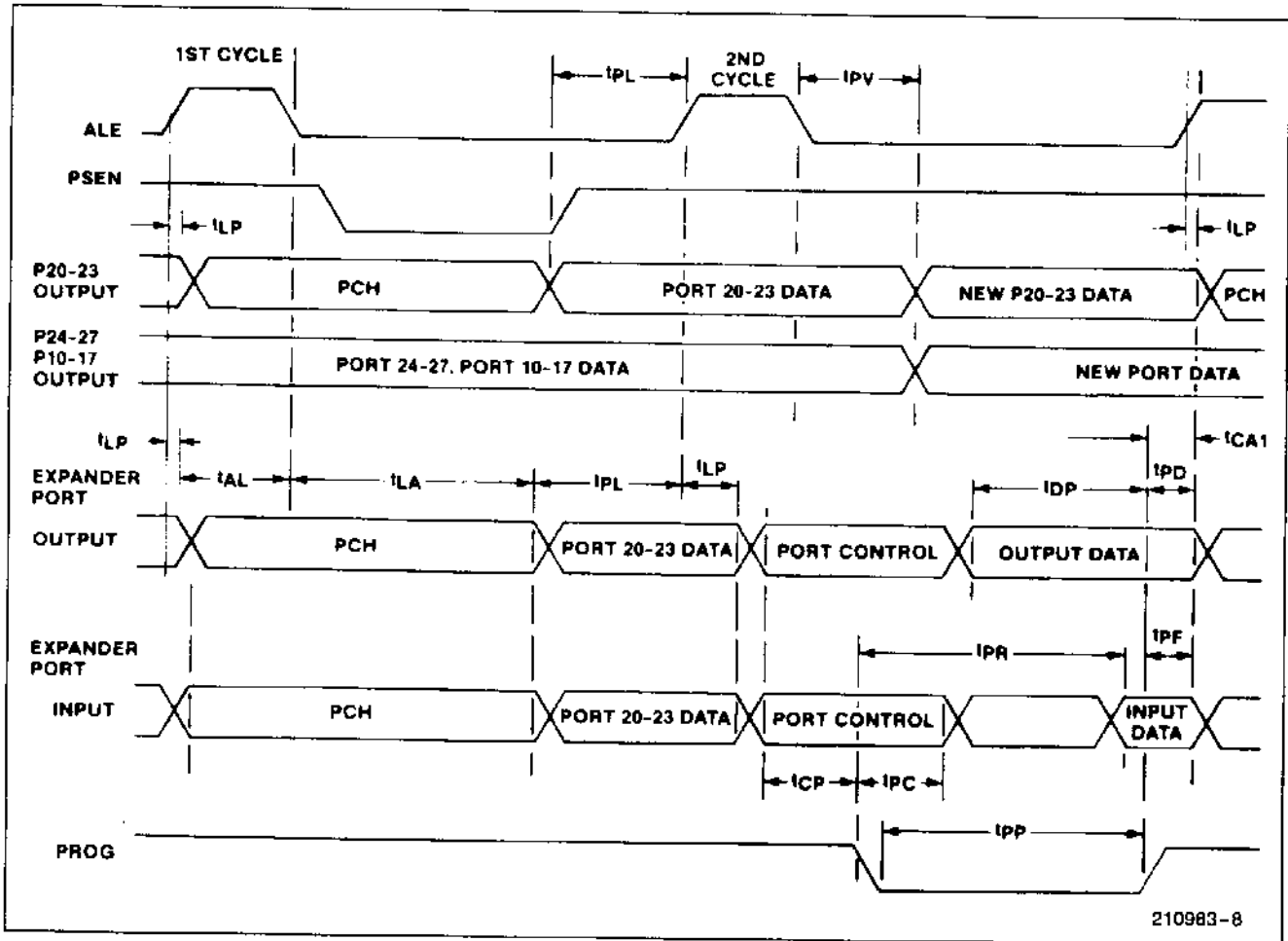

1

CRYSTAL OSCILLATOR MODE

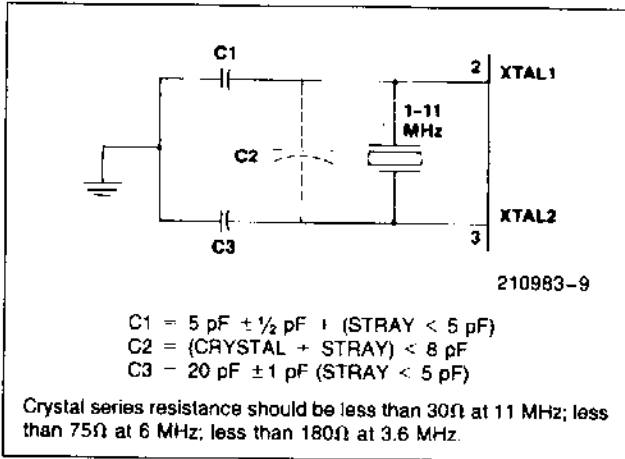

CERAMIC RESONATOR MODE

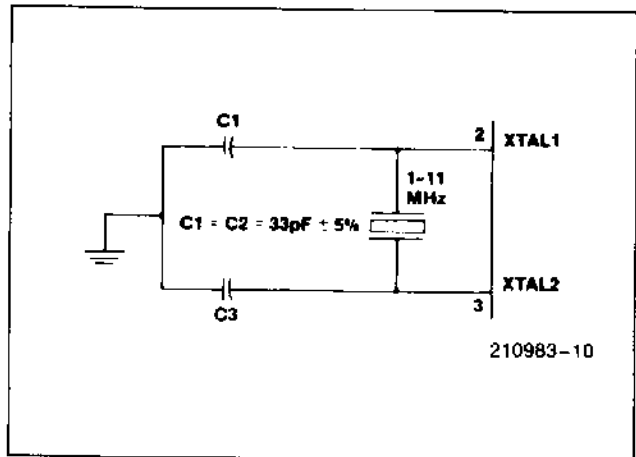

DRIVING FROM EXTERNAL SOURCE

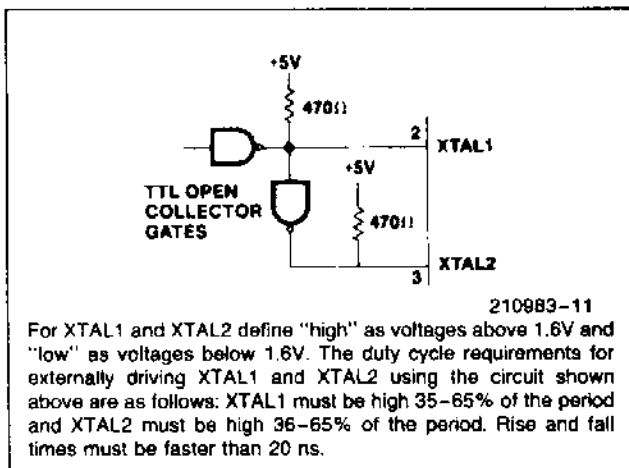

PROGRAMMING, VERIFYING AND ERASING THE 8749H (8748H) EPROM

Programming Verification

In brief, the programming process consists of: activating the program mode, applying an address, latching the address, applying data, and applying a programming pulse. Each word is programmed completely before moving on to the next and is followed by a verification step. The following is a list of the pins used for programming and a description of their functions:

Pin	Function
XTAL 1	Clock Input (3 to 4.0 MHz)
XTAL 2	
RESET	Initialization and Address Latching
TEST 0	Selection of Program or Verify Mode
EA	Activation of Program/Verify Modes
BUS	Address and Data Input
	Data Output During Verify
P20-P22	Address Input
V _{DD}	Programming Power Supply
PROG	Program Pulse Input

WARNING

An attempt to program a missocketed 8749H (8748H) will result in severe damage to the part. An indication of a properly socketed part is the appearance of the ALE clock output. The lack of this clock may be used to disable the programmer.

The Program/Verify sequence is:

- 1) V_{DD} = 5V, Clock applied or internal oscillator operating. RESET = 0V, TEST 0 = 5V, EA = 5V, BUS and PROG floating. P10 and P11 must be tied to ground.
- 2) Insert 8749H (8748H) in programming socket.
- 3) TEST 0 = 0V (select program mode)
- 4) EA = 18V (activate program mode)
- 5) Address applied to BUS and P20-22
- 6) RESET = 5V (latch address)
- 7) Data applied to BUS
- 8) V_{DD} = 21V (programming power)
- 9) PROG = V_{CC} or float followed by one 50 ms pulse to 18V
- 10) V_{DD} = 5V
- 11) TEST 0 = 5V (verify mode)
- 12) Read and verify data on BUS
- 13) TEST 0 = 0V
- 14) RESET = 0V and repeat from step 5
- 15) Programmer should be at conditions of step 1 when 8749H (8748H) is removed from socket.

AC TIMING SPECIFICATION FOR PROGRAMMING 8748H/8749H
 $T_A = 25^\circ\text{C} \pm 5^\circ\text{C}; V_{CC} = 5\text{V} \pm 5\%; V_{DD} = 21\text{V} \pm 0.5\text{V}$

Symbol	Parameter	Min	Max	Unit	Test Conditions
t_{AW}	Address Setup Time to $\overline{\text{RESET}} \uparrow$	$4t_{CY}$			
t_{WA}	Address Hold Time after $\overline{\text{RESET}} \uparrow$	$4t_{CY}$			
t_{DW}	Data in Setup Time to PROG \uparrow	$4t_{CY}$			
t_{WD}	Data in Hold Time after PROG \downarrow	$4t_{CY}$			
t_{PH}	$\overline{\text{RESET}}$ Hold Time to Verify	$4t_{CY}$			
t_{VDDW}	V_{DD} Hold Time before PROG \uparrow	0	1.0	ms	
t_{VDDH}	V_{DD} Hold Time after PROG \downarrow	0	1.0	ms	
t_{PW}	Program Pulse Width	50	60	ms	
t_{TW}	TEST 0 Setup Time for Program Mode	$4t_{CY}$			
t_{WT}	TEST 0 Hold Time after Program Mode	$4t_{CY}$			
t_{DO}	TEST 0 to Data Out Delay		$4t_{CY}$		
t_{WW}	$\overline{\text{RESET}}$ Pulse Width to Latch Address	$4t_{CY}$			
t_r, t_f	V_{DD} and PROG Rise and Fall Times	0.5	100	μs	
t_{CY}	CPU Operation Cycle Time	3.75	5	μs	
t_{RE}	$\overline{\text{RESET}}$ Setup Time before EA \uparrow	$4t_{CY}$			

NOTE:

 If TEST 0 is high, t_{DO} can be triggered by $\overline{\text{RESET}} \uparrow$.

DC SPECIFICATION FOR PROGRAMMING 8748H/8749H
 $T_A = 25^\circ\text{C} \pm 5^\circ\text{C}; V_{CC} = 5\text{V} \pm 5\%; V_{DD} = 21\text{V} \pm 0.5\text{V}$

Symbol	Parameter	Min	Max	Unit	Test Conditions
V_{DDH}	V_{DD} Program Voltage High Level	20.5	21.5	V	
V_{DDL}	V_{DD} Voltage Low Level	4.75	5.25	V	
V_{PH}	PROG Program Voltage High Level	17.5	18.5	V	
V_{PL}	PROG Voltage Low Level	4.0	V_{CC}	V	
V_{EAH}	EA Program or Verify Voltage High Level	17.5	18.5	V	
I_{DD}	V_{DD} High Voltage Supply Current		20.0	mA	
I_{PROG}	PROG High Voltage Supply Current		1.0	mA	
I_{EA}	EA High Voltage Supply Current		1.0	mA	

1

WAVEFORMS

COMBINATION PROGRAM/VERIFY MODE (EPROMs ONLY)

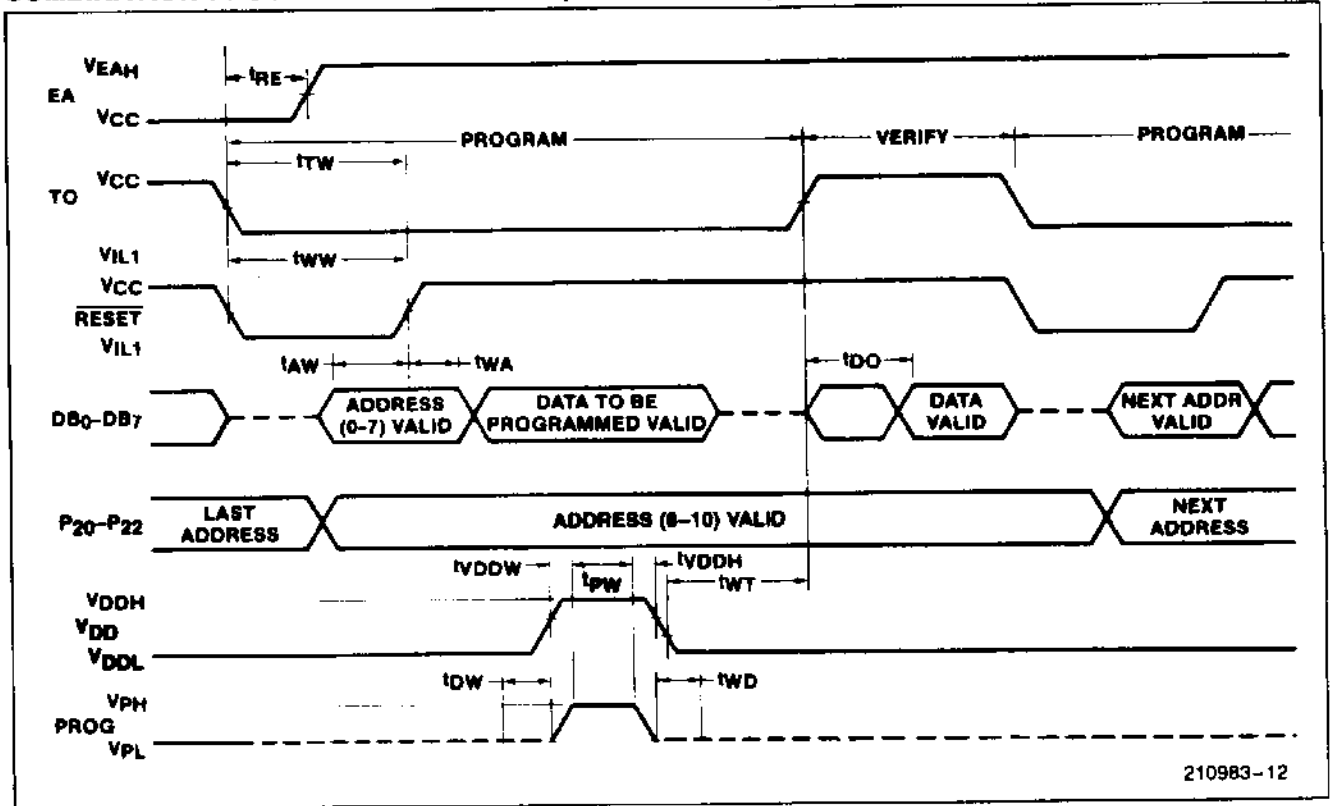

VERIFY MODE

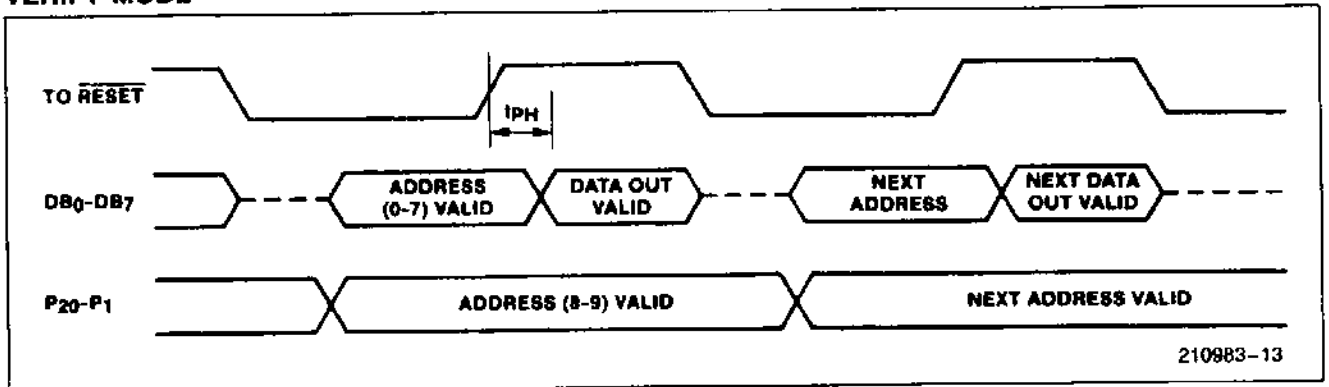

SUGGESTED EPROM VERIFICATION ALGORITHM FOR HMOS-E DEVICE ONLY

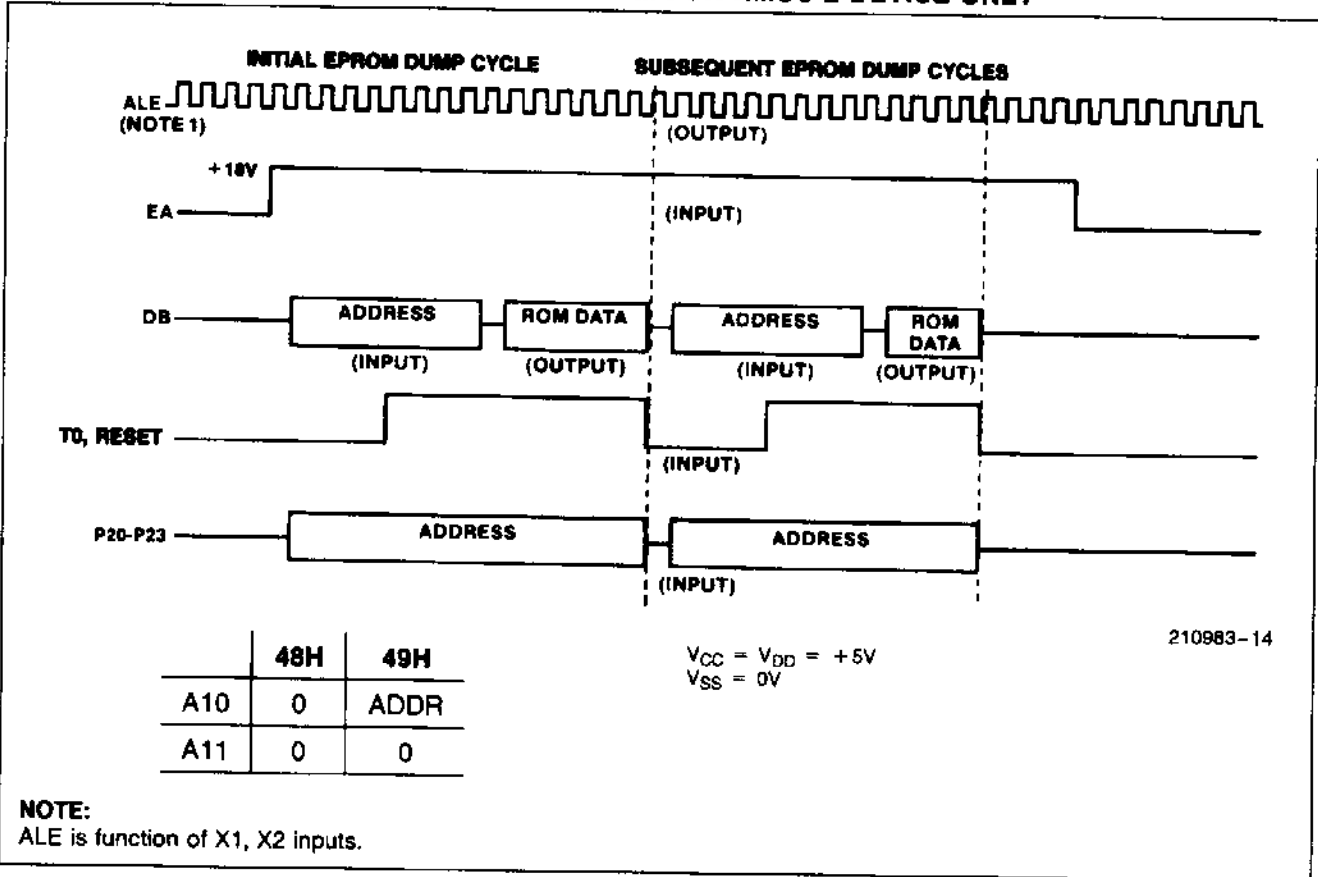

1

	48H	49H
A10	0	ADDR
A11	0	0

V_{CC} = V_{DD} = +5V
V_{SS} = 0V

210983-14

NOTE:
ALE is function of X1, X2 inputs.