

## DS26LS31C/DS26LS31M Quad High Speed Differential Line Driver

### General Description

The DS26LS31 is a quad differential line driver designed for digital data transmission over balanced lines. The DS26LS31 meets all the requirements of EIA Standard RS-422 and Federal Standard 1020. It is designed to provide unipolar differential drive to twisted-pair or parallel-wire transmission lines.

The circuit provides an enable and disable function common to all four drivers. The DS26LS31 features TRI-STATE® outputs and logically ANDed complementary outputs. The inputs are all LS compatible and are all one unit load.

### Features

- Output skew—2.0 ns typical
- Input to output delay—10 ns typical
- Operation from single 5V supply
- Outputs won't load line when  $V_{CC} = 0V$
- Four line drivers in one package for maximum package density
- Output short-circuit protection
- Complementary outputs
- Meets the requirements of EIA Standard RS-422
- Pin compatible with AM26LS31
- Available in military and commercial temperature range

### Logic and Connection Diagrams

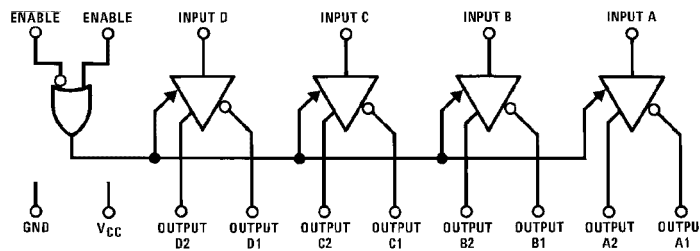

DS005778-1

Dual-In-Line Package

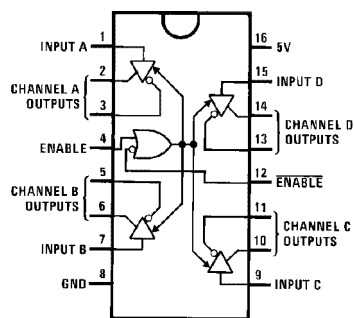

DS005778-2

Top View  
 Order Number DS26LS31CJ, DS26LS31CM,  
 DS26LS31CN or DS26LS31MJ  
 See NS Package Number J16A, M16A or N16A  
 For Complete Military 883 Specifications, see RETS Data Sheet.  
 Order Number DS26LS31MJ/883 or DS26LS31MW/883  
 See NS Package J16A or W16A

TRI-STATE® is a registered trademark of National Semiconductor Corporation.

## Absolute Maximum Ratings (Note 2)

If Military/Aerospace specified devices are required, please contact the National Semiconductor Sales Office/Distributors for availability and specifications.

Supply Voltage	7V
Input Voltage	7V
Output Voltage	5.5V
Output Voltage (Power OFF)	-0.25 to 6V
Maximum Power Dissipation (Note 1) at 25°C	
Cavity Package	1509 mW
Molded DIP Package	1476 mW
SO Package	1051 mW

## Operating Conditions

	Min	Max	Units
Supply Voltage, $V_{CC}$			
DS26LS31M	4.5	5.5	V
DS26LS31	4.75	5.25	V
Temperature, $T_A$			
DS26LS31M	-55	+125	°C
DS26LS31	0	+70	°C

**Note 1:** Derate cavity package 10.1 mW/°C above 25°C; derate molded DIP package 11.9 mW/°C above 25°C; derate SO package 8.41 mW/°C above 25°C.

## Electrical Characteristics (Notes 3, 4, 5)

Symbol	Parameter	Conditions	Min	Typ	Max	Units
$V_{OH}$	Output High Voltage	$I_{OH} = -20$ mA	2.5			V
$V_{OL}$	Output Low Voltage	$I_{OL} = 20$ mA			0.5	V
$V_{IH}$	Input High Voltage		2.0			V
$V_{IL}$	Input Low Voltage				0.8	V
$I_{IL}$	Input Low Current	$V_{IN} = 0.4$ V		-40	-200	μA
$I_{IH}$	Input High Current	$V_{IN} = 2.7$ V			20	μA
$I_I$	Input Reverse Current	$V_{IN} = 7$ V			0.1	mA
$I_O$	TRI-STATE Output Current	$V_O = 2.5$ V			20	μA
		$V_O = 0.5$ V			-20	μA
$V_{CL}$	Input Clamp Voltage	$I_{IN} = -18$ mA			-1.5	V
$I_{SC}$	Output Short-Circuit Current		-30		-150	mA
$I_{CC}$	Power Supply Current	All Outputs Disabled or Active		35	60	mA

## Switching Characteristics

$V_{CC} = 5$  V,  $T_A = 25$  °C

Symbol	Parameter	Conditions	Min	Typ	Max	Units
$t_{PLH}$	Input to Output	$C_L = 30$ pF		10	15	ns
$t_{PHL}$	Input to Output	$C_L = 30$ pF		10	15	ns
Skew	Output to Output	$C_L = 30$ pF		2.0	6.0	ns
$t_{LZ}$	Enable to Output	$C_L = 10$ pF, S2 Open		15	35	ns
$t_{HZ}$	Enable to Output	$C_L = 10$ pF, S1 Open		15	25	ns
$t_{ZL}$	Enable to Output	$C_L = 30$ pF, S2 Open		20	30	ns
$t_{ZH}$	Enable to Output	$C_L = 30$ pF, S1 Open		20	30	ns

**Note 2:** "Absolute Maximum Ratings" are those values beyond which the safety of the device cannot be guaranteed. They are not meant to imply that the devices should be operated at these limits. The tables of "Electrical Characteristics" provide conditions for actual device operation.

**Note 3:** Unless otherwise specified min/max limits apply across the -55°C to +125°C temperature range for the DS726LS31M and across the 0°C to +70°C range for the DS26LS31. All typicals are given for  $V_{CC} = 5$  V and  $T_A = 25$  °C.

**Note 4:** All currents into device pins are positive; all currents out of device pins are negative. All voltages are referenced to ground unless otherwise specified.

**Note 5:** Only one output at a time should be shorted.

## AC Test Circuit and Switching Time Waveforms

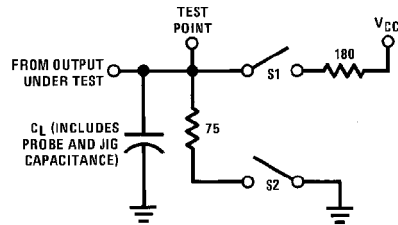

DS005778-3

S1 and S2 of load circuit are closed except where shown.

FIGURE 1. AC Test Circuit

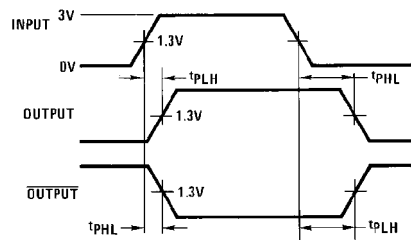

DS005778-4

$f = 1 \text{ MHz}$ ,  $t_r \leq 15 \text{ ns}$ ,  $t_f \leq 6 \text{ ns}$

FIGURE 2. Propagation Delays

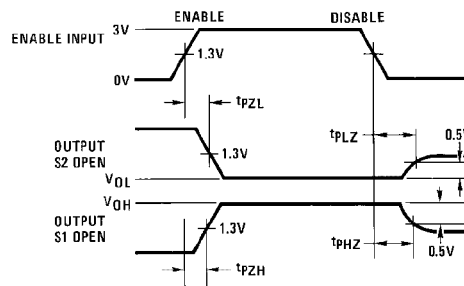

DS005778-5

$f = 1 \text{ MHz}$ ,  $t_r \leq 15 \text{ ns}$ ,  $t_f \leq 6 \text{ ns}$

FIGURE 3. Enable and Disable Times

## Typical Applications

### Two-Wire Balanced System, RS-422

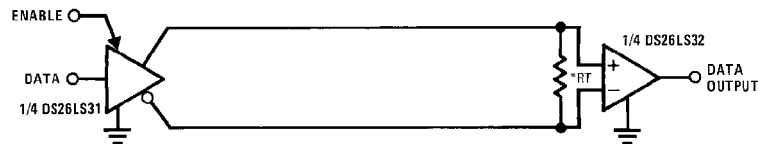

DS005778-6

Note 6:  $R_T$  is optional although highly recommended to reduce reflection.

## Typical Performance Characteristics

**DS26LS31CN Unloaded  $I_C$  vs Frequency vs  $T_A$**

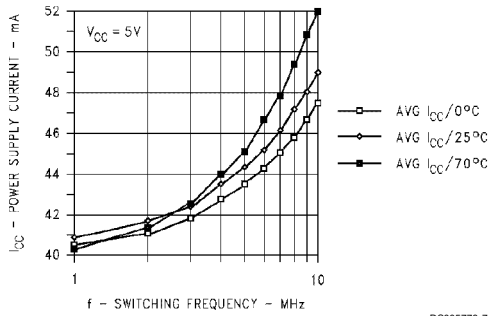

**DS26LS31  $I_{CC}$  vs  $V_{CC}$  vs  $T_A$**

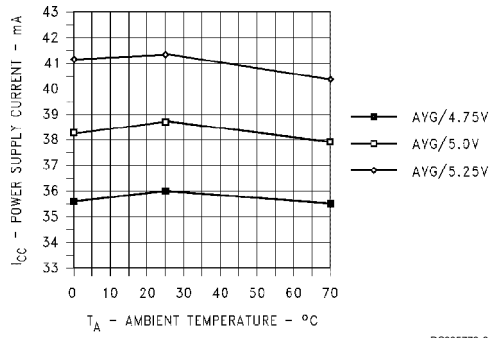

**DS26LS31CN  $V_{OH}$  vs  $I_{OH}$  vs  $T_A$**

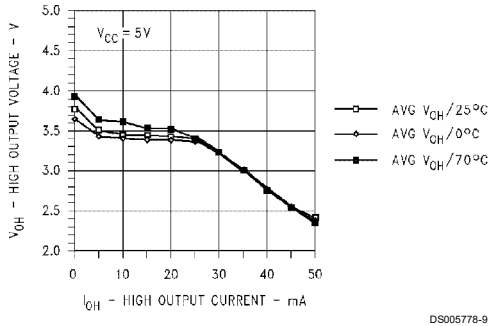

**DS26LS31CN  $V_{OL}$  vs  $I_{OL}$  vs  $T_A$**

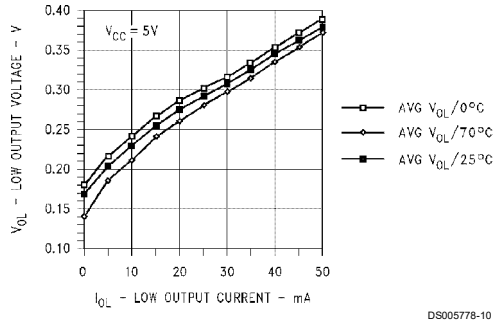

**DS26LS31CN  $V_{OD}$  vs  $I_O$  vs  $T_A$**

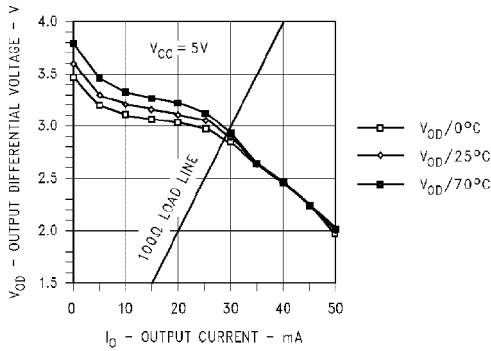

THIS PAGE IS IGNORED IN THE DATABOOK

+

|

+

+

**Physical Dimensions** inches (millimeters)

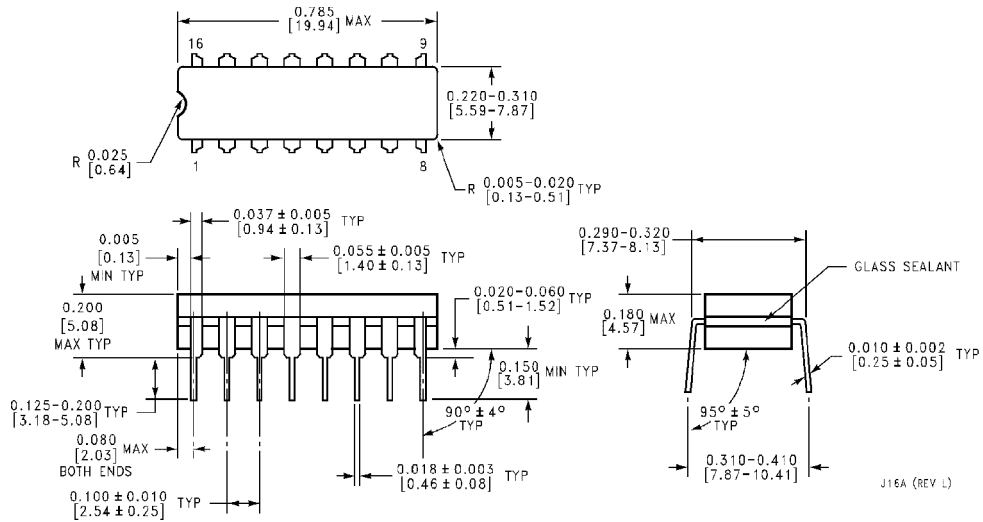

**Ceramic Dual-In-Line Package (J)**  
**Order Number DS26LS31CJ or DS26LS31MJ**  
**NS Package Number J16A**

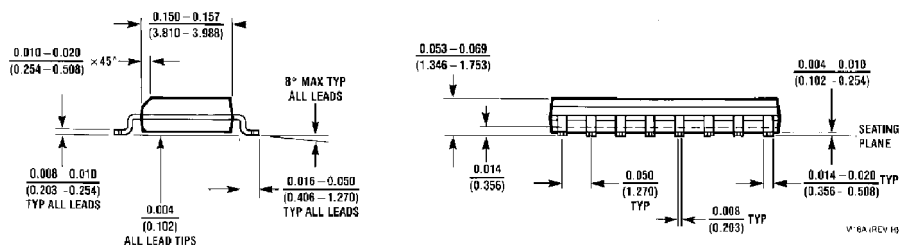
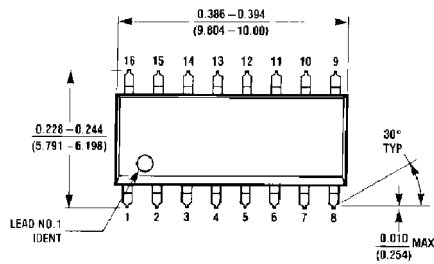

**Small Outline Package (M)**  
**Order Number DS26LS31CM**  
**NS Package Number M16A**

**Physical Dimensions** inches (millimeters) (Continued)

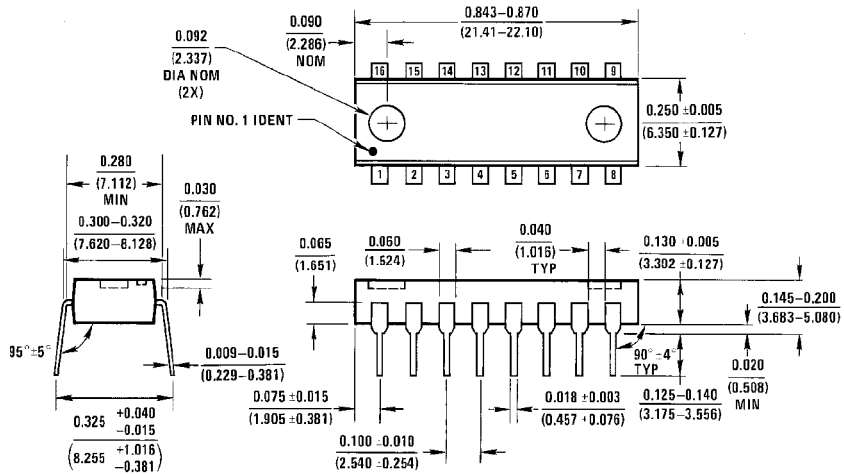

N16A (REV E)

**Molded Dual-In-Line Package (N)**  
Order Number DS26LS31CN  
NS Package Number N16A

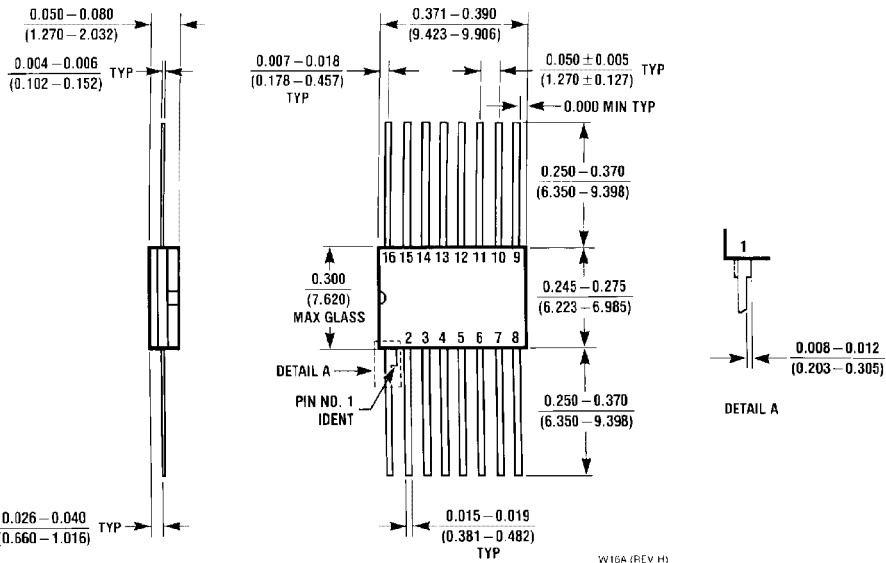

W16A (REV H)

**16 Lead Ceramic Flatpak (F)**  
NS Package Number W16A

**LIFE SUPPORT POLICY**

NATIONAL'S PRODUCTS ARE NOT AUTHORIZED FOR USE AS CRITICAL COMPONENTS IN LIFE SUPPORT DEVICES OR SYSTEMS WITHOUT THE EXPRESS WRITTEN APPROVAL OF THE PRESIDENT OF NATIONAL SEMICONDUCTOR CORPORATION. As used herein:

1. Life support devices or systems are devices or systems which, (a) are intended for surgical implant into the body, or (b) support or sustain life, and whose failure to perform when properly used in accordance with instructions for use provided in the labeling, can be reasonably expected to result in a significant injury to the user.
2. A critical component in any component of a life support device or system whose failure to perform can be reasonably expected to cause the failure of the life support device or system, or to affect its safety or effectiveness.



**National Semiconductor Corporation**  
 1111 West Bardin Road  
 Arlington, TX 76017  
 Tel: 1(800) 272-9959  
 Fax: 1(800) 737-7018

[www.national.com](http://www.national.com)

**National Semiconductor Europe**

Fax: (+49) 0-180-530 85 86  
 Email: [cnjwge@tevm2.nsc.com](mailto:cnjwge@tevm2.nsc.com)  
 Deutsch Tel: (+49) 0-180-530 85 85  
 English Tel: (+49) 0-180-532 78 32  
 Français Tel: (+49) 0-180-532 93 58  
 Italiano Tel: (+49) 0-180-534 16 80

**National Semiconductor Hong Kong Ltd.**

13th Floor, Straight Block,  
 Ocean Centre, 5 Canton Rd.  
 Tsimshatsui, Kowloon  
 Hong Kong  
 Tel: (852) 2737-1600  
 Fax: (852) 2736-9960

**National Semiconductor Japan Ltd.**

Tel: 81-043-299-2308  
 Fax: 81-043-299-2408

National does not assume any responsibility for use of any circuitry described, no circuit patent licenses are implied and National reserves the right at any time without notice to change said circuitry and specifications.