

# DP83223A TWISTER™ High Speed Networking Transceiver Device

## General Description

The DP83223A Twisted Pair Transceiver is an integrated circuit capable of driving and receiving either binary or MLT-3 encoded datastreams. The DP83223A Transceiver is designed to interface directly with standards compliant FDDI, 100BASE-TX or STS-3C ATM chip sets allowing low cost data links over copper based media. The DP83223A allows links of up to 100 meters over both Shielded Twisted Pair (STP) and datagrade Unshielded Twisted Pair (UTP) or equivalent. The electrical performance of the DP83223A meets or exceeds all performance parameters specified in the ANSI X3T9.5 TP-PMD draft standard, the IEEE 802.3 100BASE-TX Fast Ethernet Specification and the ATM Forum 155 Mbps Twisted Pair PMD Interface Specification. The DP83223A also provides important features such as baseline restoration, TRI-STATE® capable transmit outputs, and controlled transmit output edge rates (to reduce EMI radiation) for both binary and MLT-3 modes of operation.

## Features

- Compliant with ANSI X3T9.5 TP-PMD draft standard
- Compliant with IEEE 802.3 100BASE-TX Ethernet draft standard
- Compliant with ATM Forum 155 Mbps Twisted Pair Specification
- Integrated baseline restoration circuit
- Integrated transmitter and receiver with adaptive equalization circuit
- Programmable binary or MLT-3 operation
- Isolated TX and RX power supplies for minimum noise coupling
- Controlled transmit output edge rates for reduced EMI
- Tri-State capable current transmit outputs
- Loopback feature for board diagnostics
- Programmable transmit voltage amplitude

## Block Diagram

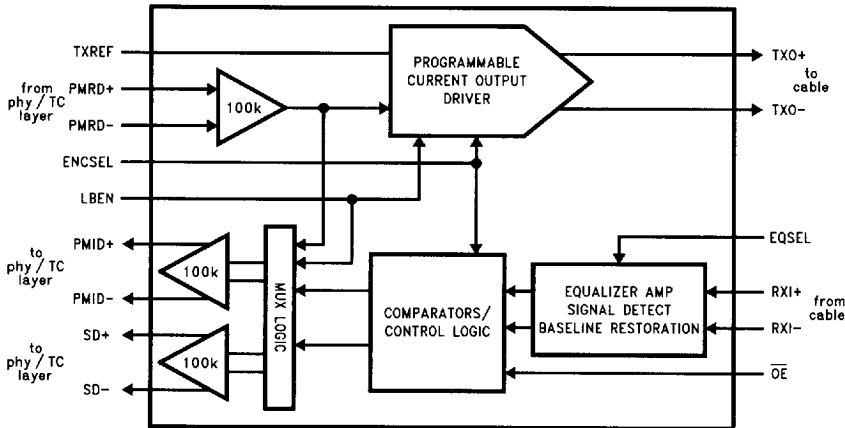

FIGURE 1. DP83223A Transceiver Block Diagram

TL/F/11886-1

TWISTER™ is a trademark of National Semiconductor Corporation.  
TRI-STATE® is a registered trademark of National Semiconductor Corporation.

# 1.0 Functional Description

## OVERVIEW

The DP83223A TWISTER is an enhanced version of the DP83223 transceiver device. The new DP83223A device has been designed to be backward compatible with the existing DP82223 device such that current PMD designs based on the DP83223 will accept, without modification, the new DP83223A device.

The DP83223A consists of seven major functional blocks as shown in *Figure 1*. The Transmit section consists of a 100K ECL input buffer for PMRD± and the Programmable Current Output Driver. The Programmable Current Output Driver can be configured to convert the incoming binary (NRZ or NRZI) datastream to a current sourced MLT-3 encoded datastream or current sourced binary datastream depending on the state of the ENCSEL input pin.

The Receive section consists of the following functional blocks: a differential input Equalization Amplifier with Signal Detect and baseline restoration circuitry, signal Comparators with Control Logic, Loopback Multiplexer Logic, and differential 100K ECL output drivers for PMID and Signal Detect.

In adaptive or full equalization mode, as selected by the EQSEL input pin, the receive data is first equalized and then amplified for signal detection. If the receive equalizer is turned off, the data is then only amplified for signal detection. In either case, the average baseline of the incoming signal is continuously monitored and restored given any baseline wander that may occur.

The Comparator/Control Logic block performs several functions. Primarily, the comparators either quantize and decode incoming MLT-3 into binary or simply quantize the incoming binary signal depending on the state of the ENCSEL input. The control logic receives input from OE and ENCSEL enabling final signal detect indication and control of data regeneration.

The Loopback Multiplexer logic performs the function of routing the transmit data at the PMRD± inputs to either the PMID± pins (loopback enabled) or to the TXO± current outputs (normal operation).

Finally, 100K ECL output drivers are used to drive both PMID± receive data and SD± Signal Detect data to the appropriate clock recovery circuit.

### 1.1 ENCODE/DECODE

The PMRD± inputs of the DP83223A TWISTER will accept either NRZ or NRZI PECL binary up to 155 Mbps. With the ENCSEL (Encode Select) input pin forced low, binary data is asynchronously encoded to a current sourced MLT-3 data stream for transmission. For twisted pair FDDI or 100BASE-TX implementations, NRZI data (as provided by the Physical Layer) is required.

With ENCSEL forced high, incoming binary data is not encoded but is directly converted to a current sourced binary datastream. For 155 Mbps twisted pair ATM, the data presented to the PMID± inputs is NRZ formatted. Therefore, the TXO± outputs source NRZ data for transmission.

The receiver function of the DP83223A TWISTER is also determined by the state of the ENCSEL pin. With ENCSEL forced low, the receiver will decode the incoming MLT-3

data stream to the original binary version. This decoded binary signal is converted to PECL levels and then routed to the PMID± outputs. With ENCSEL forced high, the incoming binary data is regenerated, converted to PECL levels and routed to the PMID± outputs.

The process of encoding binary to MLT-3 and decoding MLT-3 back to binary is illustrated in the simplified logic circuits and associated bit patterns given in *Figures 2* and *3*.

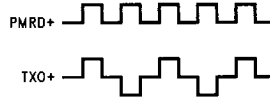
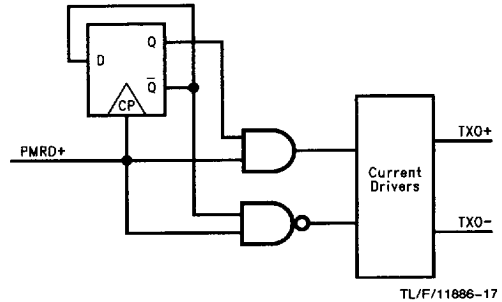

**FIGURE 2. Binary to MLT-3 Encoding**

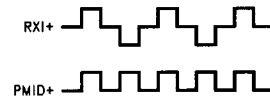
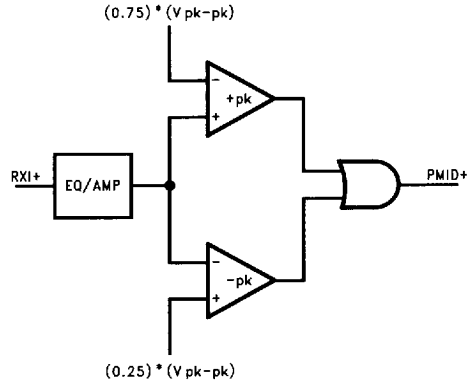

**FIGURE 3. MLT-3 to Binary Decoding**

## 1.0 Functional Description (Continued)

### 1.2 BASELINE RESTORATION

The DP83223A TWISTER has been designed to correct for baseline wander as defined in the ANSI FDDI TP-PMD specification. Baseline wander can generally be defined as the change in the average DC content, over time, of an AC coupled digital transmission over a given transmission medium. (i.e., copper wire)

Baseline wander results from the interaction between the low frequency components of a bit stream being transmitted and the frequency response of the AC coupling component(s) within the transmission system. If the low frequency content of the digital bit stream goes below the low frequency pole of the AC coupling transformers then the droop characteristics of the transformers will dominate resulting in potentially serious baseline wander.

The digital oscilloscope plot provided in *Figure 4* illustrates the severity of the baseline wander event generated by the frame specified in the ANSI FDDI TP-PMD standard. This event consists of a DC offset of approximately 750 mV with a period of approximately 360  $\mu$ s. Left uncompensated, this event would cause many bit errors which could potentially isolate the receiving node from the FDDI network.

It is interesting to note that the probability of a baseline wander event serious enough to corrupt data is very low. In fact, it is reasonable to virtually bound the occurrence of a baseline wander event serious enough to cause bit errors to a legal but premeditated, artificially constructed bit sequence loaded into the original MAC frame. Several studies have been conducted to evaluate the probability of various baseline wander events for FDDI transmission over copper. Contact the X3T9 ANSI group for further information.

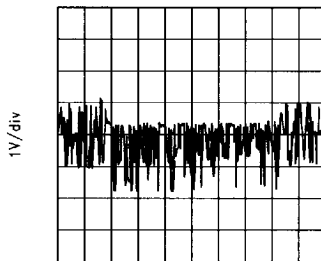

FIGURE 4. Baseline Wander Event

TL/F/11886-21

### 1.3 TRANSMIT AMPLITUDE CONTROL

The transmit amplitude of the signal presented at the TXO output pins can be controlled by varying the value of resistance between TXREF and TXGND. This TXREF resistor,  $R_{REF}$ , sets up a reference current which determines the final output current at TXO  $\pm$ . The DP83223A TWISTER will also automatically set the TXREF scaling factor to provide the correct transmit amplitude based on the selected mode of operation (MLT-3 or binary) without having to change the value of the TXREF resistor.

For 100 $\Omega$  Category-5 UTP cable implementations, the value of the TXREF resistor ( $R_{REF}$ ) is currently set at 510 $\Omega$ . This will yield either a 2  $V_{pk-pk}$  differential transmit amplitude for MLT-3 or a 1  $V_{pk-pk}$  differential transmit amplitude for binary. The following equations are useful for calculating  $R_{REF}$ :

$$R_{REF} = \frac{10.24 * Z_{CABLE}}{V_{OUT} (MLT-3)} \quad \text{or} \quad R_{REF} = \frac{5.12 * Z_{CABLE}}{V_{OUT} (binary)}$$

where:

- $R_{REF}$  is the TX amplitude reference resistor in Ohms ( $\Omega$ )
- $Z_{CABLE}$  is the characteristic differential impedance of the desired twisted pair cable ( $\Omega$ )
- $V_{OUT}$  is the differential peak-peak output voltage in Volts (V)
- 10.24 and 5.12 are related to the reference scaling factors

# 1.0 Functional Description (Continued)

## 1.4 TRANSITION TIME CONTROL

The transition times of the TXO± output signals are digitally synthesized resulting in closely matched and controlled rise and fall times. As with the previous TWISTER, the new DP83223A TWISTER incorporates this unique feature which significantly reduces the need for external filtering of the transmitted signal. The combination of these controlled edge rates and inexpensive magnetics (without additional filtering) generates clean rise and fall times compliant with the ANSI X3T9.5 TP-PMD draft standard, the IEEE 802.3 100BASE-TX Fast Ethernet Specification and the ATM Forum 155 Mbps Twisted Pair PMD Interface Specification. In addition, control of the transmitter transition times reduces the EMI related board layout sensitivities. This offers a distinct advantage over transceivers dependent on external filtering for transition time control.

Figure 5 compares the power spectrum of two transmitters each driving a 1V binary scrambled HALT bitstream into a 100Ω load through a typical 350 μH 1:1 transformer. The power spectrum curve exhibiting lower relative power is from the DP83223A TWISTER transmitter with controlled output transition times. The curve exhibiting the higher relative power is from a transmitter which does not control the output transition time and therefore, would require additional external filtering to limit bandwidth and radiated emissions. The curves in Figure 6 make the same comparison for 2V MLT-3 transmission where the DP83223A TWISTER again exhibits lower relative power, eliminating the need for additional external transmit filtering.

## 1.5 ADAPTIVE EQUALIZATION

When transmitting data at high speeds over copper twisted pair cable, frequency dependent attenuation becomes a concern. In high speed twisted pair signalling the frequency content of the transmitted signal can vary greatly during normal operation based primarily on the randomness of the scrambled data stream. This variation in signal attenuation caused by frequency variations must be compensated for to ensure the integrity of the transmission.

In order to ensure quality transmission when employing MLT-3 encoding, (and to a lesser extent, binary) the compensation must be able to adapt to various cable lengths and cable types depending on the installed environment. The selection of long cable lengths for a given implementation, requires significant compensation which will over-compensate for shorter, less attenuating lengths. Conversely, the selection of short or intermediate cable lengths requiring less compensation will cause serious under-compensation for longer length cables. Therefore, the compensation or equalization must be adaptive to ensure proper conditioning of the received signal regardless of the of the installed media.

In order to implement receiver adaptive equalization, a known relationship between transmit output amplitude and a receive input reference must be specified and controlled. Given these two parameters, the adaptive equalizer can determine the approximate cable length via signal attenuation at certain frequencies and actively compensate for cable variations.

The curves given in Figure 7 provide insight to the actual attenuation at certain frequencies for given cable lengths. This is derived from the worst case frequency vs. attenuation figures as specified in the EIA/TIA Bulletin TSB-36. These curves indicate the significant variations in signal attenuation that must be compensated for by the receive adaptive equalization circuit.

As a measure of operation, Figures 8 through 13 indicate the performance and function of the adaptive equalizer in terms of jitter for a 2 V<sub>pk-pk</sub> differential MLT-3 signal.

Figure 8 represents a scrambled HALT, transmitted over 0 Meters of Category-5 cable as measured at the All (Active Input Interface) of the receiver. Figure 9 represents the jitter of the recovered PECL data as measured differentially at the PMID± outputs. Figures 10 and 11 represent the performance over 50 Meters of Category-5 Cable and Figures 12 and 13 represent performance over 100 Meters of Category-5 cable.

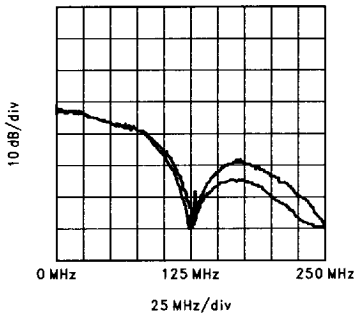

FIGURE 5. 1V Binary Power Spectrum with and without Edge Rate Control

TL/F/11886-22

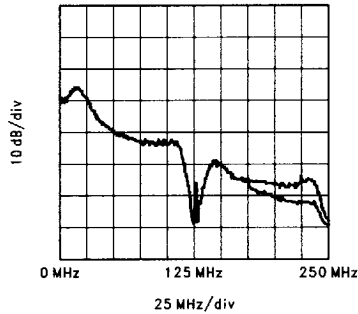
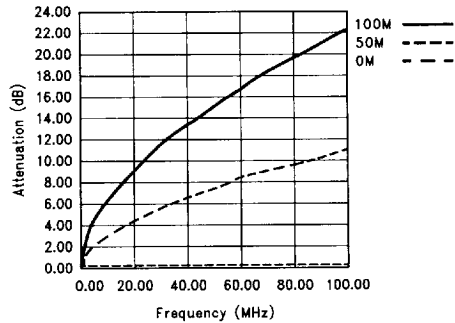

FIGURE 6. 2V MLT-3 Power Spectrum with and without Edge Rate Control

TL/F/11886-23

# 1.0 Functional Description (Continued)



**FIGURE 7. EIA/TIA Attenuation vs Frequency for 0, 50 and 100 Meters of CAT-5 Cable**

TL/F/11886-24

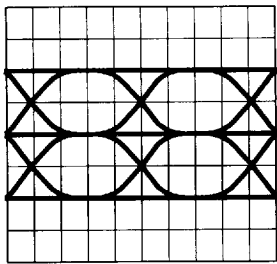

2 ns/div

TL/F/11886-25

**FIGURE 8. MLT-3 Signal Measured at All after 0M of CAT-5 Cable**

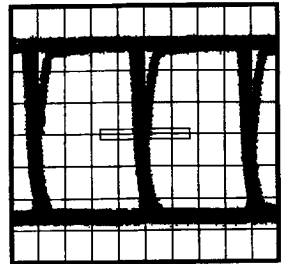

2ns/div

TL/F/11886-26

**FIGURE 9. Recovered ECL Peak Total Jitter for 0M of CAT-5 Cable (MLT-3) 660 ps**

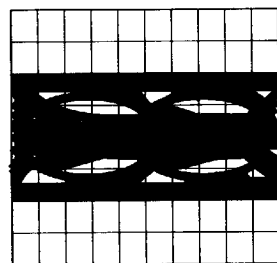

2 ns/div

TL/F/11886-27

**FIGURE 10. MLT-3 Signal Measured at All after 50M of CAT-5 Cable**

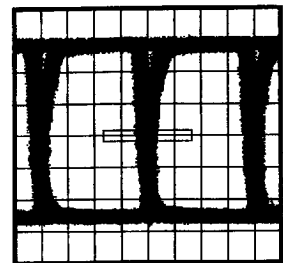

2ns/div

TL/F/11886-28

**FIGURE 11. Recovered ECL Peak Total Jitter for 50M of CAT-5 Cable (MLT-3) 1.0 ns**

# 1.0 Functional Description (Continued)

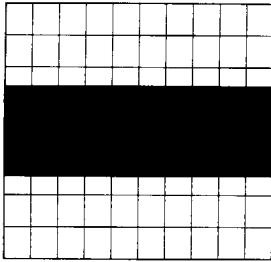

2 ns/div

TL/F/11886-29

**FIGURE 12. MLT-3 Signal Measured at All after 100M of CAT-5 Cable**

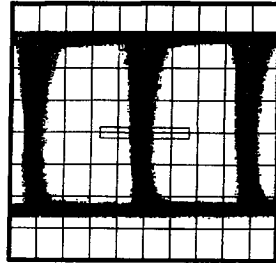

2 ns/div

TL/F/11886-30

**FIGURE 13. Recovered ECL Peak Total Jitter for 100M of CAT-5 Cable (MLT-3) 1.08 ns**

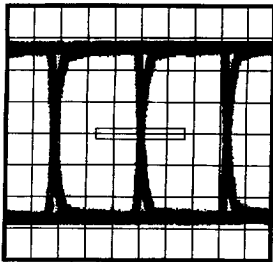

2 ns/div

TL/F/11886-31

**FIGURE 14. Recovered ECL Peak Total Jitter for 0M of CAT-5 Cable (binary) 340 ps**

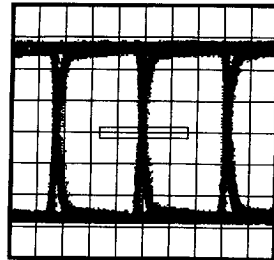

2 ns/div

TL/F/11886-32

**FIGURE 15. Recovered ECL Peak Total Jitter for 50M of CAT-5 Cable (binary) 480 ps**

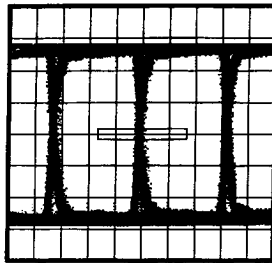

2 ns/div

TL/F/11886-33

**FIGURE 16. Recovered ECL Peak Total Jitter for 100M of CAT-5 Cable (binary) 520 ps**

# 1.0 Functional Description (Continued)

## 1.6 JITTER PERFORMANCE

This section provides additional jitter performance measured using the DP83223A TWISTER transceiver. The TWISTER was configured to transmit a scrambled HALT data stream over various lengths of cable in both MLT-3 and binary modes of operation. The 0, 50 and 100 Meter plots provided in *Figures 9, 11 and 13* represent the MLT-3 mode total jitter performance.

*Figures 14, 15 and 16* indicate the jitter performance in the binary mode of operation also over 0, 50 and 100 Meter Category-5 cable lengths. All of these jitter results are given as the peak total jitter resulting from the combination of the transmitter, cable, and receiver.

## 1.7 SIGNAL DETECT

The signal detect function of the DP83223A TWISTER is incorporated to meet the specifications mandated by the ANSI FDDI TP-PMD Standard as well as the IEEE 802.3 100BASE-TX Standard. Although there is no requirement for the signal detect function currently specified within the 155 Mbps TP-ATM specification, the TWISTER offers this function for the binary mode of operation.

The signal detect turn-on and turn-off thresholds for the TWISTER for both binary and MLT-3 modes of operation are illustrated in *Figure 17*. It is important to note that the signal detect function occurs after adaptive equalization and amplification of the received signal.

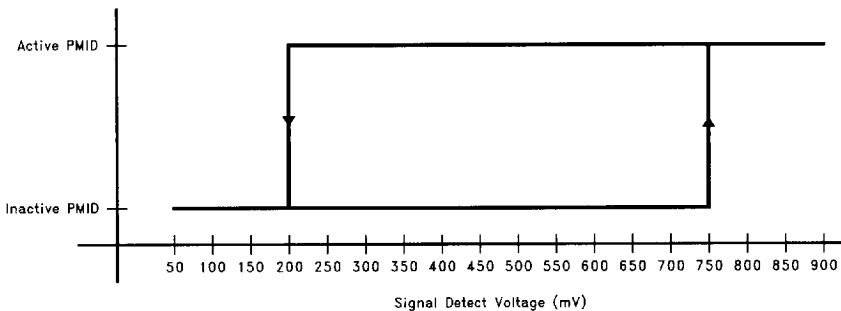

FIGURE 17. Signal Detect

TL/F/11886-34

## 1.8 OUTPUT ENABLE

The DP83223A TWISTER provides an output enable/disable function which is pin selectable via the Output Enable bar pin ( $\overline{OE}$ ). This pin was formerly labeled Cable Detect bar ( $\overline{CDET}$ ) on the previous DP83223 TWISTER. With  $\overline{OE}$  set to a logic high level, the  $TXO \pm$  current outputs are both turned off. This causes the  $TXO$  outputs to effectively TRI-STATE regardless of the selected mode of operation (MLT-3 or Binary). Additionally, the  $PMID \pm$  PECL outputs are forced to a steady state and the Signal Detect ( $SD+$ ) output is forced to a logic low ( $SD+ = 0$  and  $SD- = 1$ ). With  $\overline{OE}$  set to a logic low level, the TWISTER functions normally.

## 1.9 EQUALIZATION SELECT

The DP83223A TWISTER provides the added flexibility of controlling the type of receive equalization required for a given implementation. While adaptive equalization is the preferred method of cable compensation for TP-PMD FDDI, 100BASE-TX and 155 Mbps TP-ATM, the ability to switch the equalizer completely off or to a fixed maximum is provided.

# 1.0 Functional Description (Continued)

## 1.10 LOOPBACK OPERATION

As with the previous TWISTER, the Loopback function of the DP83223A TWISTER (LBEN = 1) routes the signal at the PMRD inputs directly to the PMID outputs and forces SD+ high. However, the new TWISTER also forces the TXO± outputs to a true Quiet line state. This is accomplished by forcing the TXO± outputs to a balanced state

where each output sources  $\frac{1}{2}$  the peak current required for the selected mode of operation (MLT-3 or Binary).

Figure 18 illustrates the normal and true Quiet line signalling for normal and loopback functions while in the MLT-3 mode of operation. Figure 19 illustrates normal and loopback signalling for binary operation. Both figures are based on implementations using 100Ω Cat-5 UTP cable.

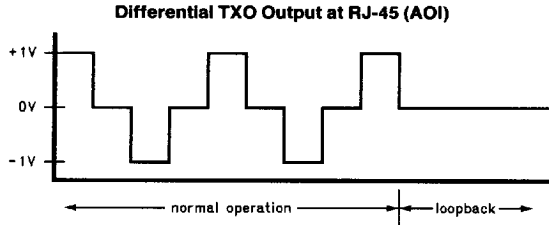

**FIGURE 18. TXO True Quiet during Loopback (MLT-3 Mode)**

TL/F/11886-35

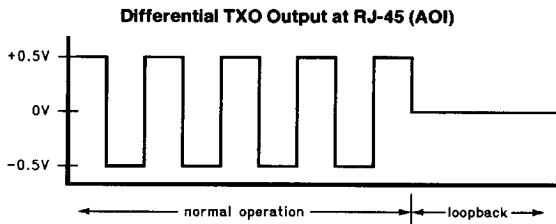

**FIGURE 19. TXO True Quiet during Loopback (Binary Mode)**

TL/F/11886-36

## 2.0 System Connection Diagrams

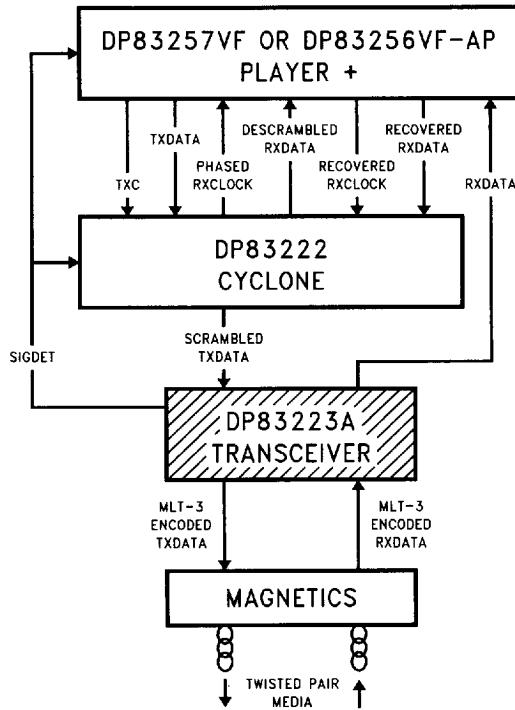

FIGURE 20. Typical TP-FDDI System Connection

TL/F/11886-37

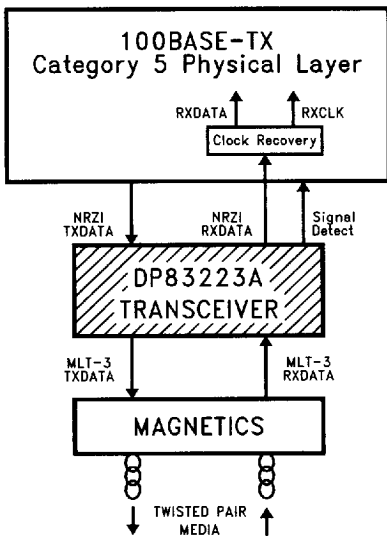

FIGURE 21. Typical 100BASE-TX System Connection

TL/F/11886-38

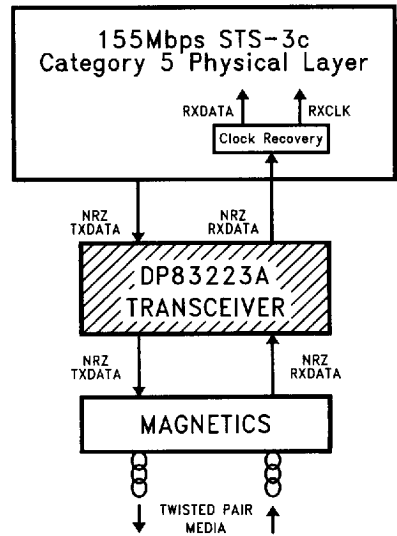
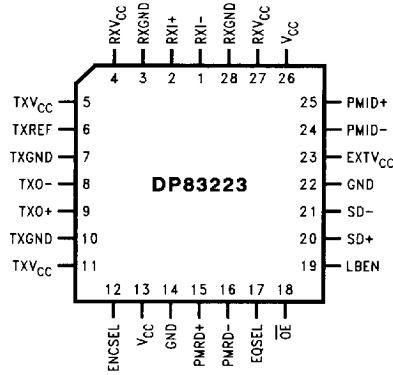

FIGURE 22. Typical STS-3c TP-ATM System Connection

TL/F/11886-39

### 3.0 Pinout Information



TL/F/11886-8

**28-Pin PLCC**  
**FIGURE 23. Pin Configuration**

#### 3.1 PINOUT SUMMARY

Signal	Pin No.	Description	Type
V <sub>CC</sub>	13, 26	V <sub>CC</sub>	Supply
GND	14, 22	GND	Supply
RXV <sub>CC</sub>	4, 27	Receive V <sub>CC</sub>	Supply
RXGND	3, 28	Receive GND	Supply
TXV <sub>CC</sub>	5, 11	Transmit V <sub>CC</sub>	Supply
TXGND	7, 10	Transmit GND	Supply
EXTV <sub>CC</sub>	23	External V <sub>CC</sub>	Supply
RXI $\pm$	2, 1	Receive Data Inputs	Differential Voltage In
PMID $\pm$	25, 24	Physical Media Indicate Data	ECL Out
PMRD $\pm$	15, 16	Physical Media Request Data	ECL In
TXO $\pm$	9, 8	Transmit Data Outputs	Differential Current Out
SD $\pm$	20, 21	Signal Detect Outputs	ECL Out
TXREF	6	Transmit Amplitude Reference	Current Out
ENCSEL	12	Encode Select Input	CMOS In
LBEN	19	Loopback Enable	CMOS In
EQSEL	17	Equalization Select	3-Level Select
OE	18	Output Enable Bar	CMOS Schmitt Trig In

## 3.0 Pinout Information (Continued)

### 3.2 PIN DEFINITIONS

**V<sub>CC</sub> (13, 26):** Positive power supply for the 100K ECL compatible circuitry. The Transceiver operates from a single +5 VDC power supply.

**GND (14, 22):** Return path for the 100K ECL compatible circuitry power supply.

**RXV<sub>CC</sub> (4, 27):** Positive power supply for the small signal receive circuitry. This power supply is intentionally separated from others to eliminate receive errors due to coupled supply noise.

**RXGND (3, 28):** Return path for the receive power supply circuitry. This power supply return is intentionally separated from others to eliminate receive errors due to coupled supply noise.

**TXV<sub>CC</sub> (5, 11):** Positive power supply required by the analog portion of the transmit circuitry. This power supply is intentionally separated from the others to prevent supply noise from coupling to the transmit outputs.

**TXGND (7, 10):** Return path for the analog transmit power supply circuitry. This supply return is intentionally separated from others to prevent supply noise from being coupled to the transmit outputs.

**EXTV<sub>CC</sub> (23):** Positive power supply for 100K ECL output circuitry.

**RXI $\pm$  (2, 1):** Balanced differential line receiver inputs. These inputs are capable of receiving either binary or MLT-3 encoded data.

**PMID $\pm$  (25, 24):** Differential 100K ECL compatible outputs which source the recovered receive-data to the appropriate clock recovery circuit.

**PMRD $\pm$  (15, 16):** Differential 100K ECL compatible inputs which accept transmit-data from the appropriate Physical Layer device

**TXO $\pm$  (9, 8):** Differential current driver outputs which drive either binary or MLT-3 encoded data over either 100 $\Omega$  or 150 $\Omega$  twisted pair cable. These outputs provide controlled rise and fall times designed to filter the transmitters output, reducing any associated EMI.

**SD $\pm$  (20, 21):** Differential 100K ECL compatible Signal Detect outputs which indicate that either a valid signal is present at the RXI $\pm$  inputs or that Loopback mode has been selected.

**TXREF (6):** Reference current pin allowing adjustment of TXO $\pm$  transmit amplitude. By placing a resistor between this pin and TXGND, a reference current is setup which results in a given transmit amplitude for a given application. Refer to section 1.3 of the Functional Description for reference current equations.

**ENCSSEL (12):** The TTL compatible CMOS Encode Select input controls the encoded state of the signal at the TXO $\pm$  outputs. A logic high level at this input causes the TXO $\pm$  pins to output binary code and configures the receiver to receive binary. A logic low level causes the TXO outputs to source MLT-3 encoded data and configures the receiver to accept MLT-3 encoded data.

**LBEN (19):** TTL compatible CMOS Loopback Enable input pin selects the internal loopback path which routes the PMRD $\pm$  data to the PMID $\pm$  differential outputs and forces Signal Detect true. During loopback operation (LBEN = 1) the TXO $\pm$  outputs source a true QUITE onto the cable. Normal operation occurs when LBEN forced low.

**EQSEL (17):** This three level Equalization Select input controls the mode of receiver equalization. Forcing a median voltage level, accomplished by allowing EQSEL to float, selects the adaptive equalization mode which automatically regulates the equalization effects based on signal degradation caused by the media. Forcing a voltage less than  $\frac{1}{3}$  of V<sub>CC</sub>, selects full equalization which provides fixed equalization for a maximum length of cable. Forcing a voltage greater than  $\frac{2}{3}$  of V<sub>CC</sub> turns the receive equalizer off.

**OE (18):** The Schmitt Trigger Output Enable bar input is provided to support the option of true transmit disable. With OE high, the signal detect output is forced low (SD+ = 0) which inhibits data reception by the PHY and the PMID outputs are forced to 100K ECL static levels (PMID+ = 0, PMID- = 1). The exception is in the case of Loopback when the Signal Detect output is forced high (SD+ = 1) regardless of all other conditions. With OE low, the transceiver functions normally.

## 4.0 Functional Truth Tables

### 4.1 OUTPUT ENABLE

Output Enable

OE	TXO Outputs	PMID + /PMID -	SD + /SD -
0	Normal Function	Normal Function	Normal Function
1	TRI-STATE	0/1	0/1

### 4.2 EQUALIZATION SELECT

Equalization Select

EQSEL	Mode
< 1.5V	Full EQ
Float	Adaptive EQ
> 3.0V	EQ Off

### 4.3 ENCODE SELECT

Encode Select

ENCSEL	Mode
0	MLT-3 (TP-FDDI/100BASE-TX)
1	Binary (155 Mbps ATM)

### 4.4 LOOPBACK SELECT

Loopback Select

LBEN	TXO Outputs	PMID Outputs	SD + /SD -
0	Normal Function	Normal Function	Normal Function
1	True Quiet	follow PMRD	1/0

The Loopback Function is intended for board diagnostics. In Loopback mode, the ECL signal applied to the PMRD inputs will appear at the PMID outputs regardless of the signal present at the RXI inputs.

## 5.0 Electrical Characteristics

### ABSOLUTE MAXIMUM RATINGS

Symbol	Parameter	Conditions	Min	Typ	Max	Units
V <sub>CC</sub>	Logic Power	Referenced to GND	-0.5		7.0	V
RXV <sub>CC</sub>	Received Power	Referenced to RXGND	-0.5		7.0	V
TXV <sub>CC</sub>	Transmit Power	Referenced to TXGND	-0.5		7.0	V
EXTV <sub>CC</sub>	ECL Output Power	Referenced to GND	-0.5		7.0	V
I <sub>ECL</sub>	DC Output Current (High)				-50	mA
ESD					2	KV
T <sub>storage</sub>	Storage Temperature		-65		+150	°C

### 5.1 RECOMMENDED OPERATING CONDITIONS

Symbol	Parameter	Conditions	Min	Typ	Max	Units
V <sub>CC</sub>	Supply Voltage		4.50	5.0	5.50	V
T <sub>A</sub>	Operating Temperature		0	25	70	°C
PD	Device Power Dissipation			700		mW

### 5.2 DC ELECTRICAL CHARACTERISTICS T<sub>A</sub> = 25°C, V<sub>CC</sub> = 5.0V

Symbol	Parameter	Conditions	Min	Typ	Max	Units
I <sub>IHt</sub>	TTL High Level Input				10	μA
I <sub>ILt</sub>	TTL Low Level Input				-10	μA
I <sub>IHSchmitt</sub>	Schmitt High Level Input				10	μA
I <sub>ILSchmitt</sub>	Schmitt Low Level Input				-10	μA
I <sub>IHeqsel</sub>	EQSEL High Level Input	Figure 24a			1000	μA
I <sub>ILeqsel</sub>	EQSEL Low Level Input	Figure 24a			-1000	μA
I <sub>IHe</sub>	ECL High Level Input				50	μA
I <sub>ILe</sub>	ECL Low Level Input				1.0	μA
V <sub>IHt</sub>	TTL High Level Input		2.0			V
V <sub>ILt</sub>	TTL Low Level Input				0.8	V
V <sub>IHSchmitt</sub>	Schmitt High Level Input			3*V <sub>CC</sub> /4		V
V <sub>ILSchmitt</sub>	Schmitt Low Level Input			V <sub>CC</sub> /4		V
V <sub>IHeqsel</sub>	EQSEL High Level Input			2*V <sub>CC</sub> /3		V
V <sub>ILeqsel</sub>	EQSEL Low Level Input			V <sub>CC</sub> /3		V
V <sub>IMeqsel</sub>	EQSEL Mid Level Input			V <sub>CC</sub> /2		V
V <sub>IHe</sub>	ECL High Level Input		V <sub>CC</sub> - 1165		V <sub>CC</sub> - 880	mV
V <sub>ILe</sub>	ECL Low Level Input		V <sub>CC</sub> - 1810		V <sub>CC</sub> - 1475	mV
V <sub>OHe</sub>	ECL High Level Output	Figure 24c	V <sub>CC</sub> - 1025		V <sub>CC</sub> - 880	mV
V <sub>OLe</sub>	ECL Low Level Output	Figure 24c	V <sub>CC</sub> - 1810		V <sub>CC</sub> - 1620	mV
I <sub>CCext</sub>	External Supply Current	Figure 24c		55		mA
I <sub>CCint1</sub>	Internal Supply Current	ENCSEL = 1, $\overline{OE}$ = 0, Figure 24c		115		mA
I <sub>CCint2</sub>	Internal Supply Current	ENCSEL = 0, $\overline{OE}$ = 0, Figure 24c		135		mA
I <sub>CCtotal1</sub>	Total Supply Current	ENCSEL = 1, $\overline{OE}$ = 0, Figure 24c		170		mA
I <sub>CCtotal2</sub>	Total Supply Current	ENCSEL = 0, $\overline{OE}$ = 0, Figure 24c		190		mA

## 5.0 Electrical Characteristics (Continued)

### 5.2 DC ELECTRICAL CHARACTERISTICS $T_A = 25^\circ\text{C}$ , $V_{CC} = 5.0\text{V}$ (Continued)

Symbol	Parameter	Conditions	Min	Typ	Max	Units
$I_{TXO\text{match}1}$	Transmit Current Matching 1	$\text{LBEN} = 1, R_{\text{REF}} = 510\Omega$ , (Note 1)		2.5		%
$I_{TXO\text{match}2}$	Transmit Current Matching 2	$\text{ENCSEL} = 0, \text{LBEN} = 0, R_{\text{REF}} = 510\Omega$ $\text{PMRD}^+ = 0, \text{PMRD}^- = 1$ (Note 1)		2.5		%
$I_{TXO\text{leak\_tri}}$	TXO TRI-STATE Leakage Current	$\text{OE} = 1, R_{\text{REF}} = 510\Omega, V_{\text{TXO}^-} = 0\text{V}$ , $V_{\text{TXO}^+} = 0\text{V}$ (Note 2)			10	$\mu\text{A}$
$\text{TX}_{\text{ref\_mult}1}$	TXREF Multiplier for Binary	$\text{ENCSEL} = 1, R_{\text{REF}} = 510\Omega$ , <i>Figure 24b</i> , (Note 3)		5.12		
$\text{TX}_{\text{ref\_mult}2}$	TXREF Multiplier for MLT-3	$\text{ENCSEL} = 0, R_{\text{REF}} = 510\Omega$ , <i>Figure 24b</i> (Note 3)		10.24		
$\text{TX}_{\text{ref\_tol}}$	TXREF Multiplier Tolerance	$\text{ENCSEL} = 1, R_{\text{REF}} = 510\Omega$		2.5		%
$\text{SD}_{\text{THon}1}$	Sig Det Turn-on Threshold 1	$\text{ENCSEL} = 1$ , <i>Figure 10</i> (Note 4)		750		mV
$\text{SD}_{\text{THon}2}$	Sig Det Turn-on Threshold 2	$\text{ENCSEL} = 0$ , <i>Figure 10</i> (Note 4)		750		mV
$\text{SD}_{\text{THoff}1}$	Sig Det Turn-off Threshold 1	$\text{ENCSEL} = 1$ , <i>Figure 10</i> (Note 4)		200		mV
$\text{SD}_{\text{THoff}2}$	Sig Det Turn-off Threshold 2	$\text{ENCSEL} = 0$ , <i>Figure 10</i> (Note 4)		200		mV
$R_{\text{InDiff}}$	RXI Differential Input Resistance			8		$\text{K}\Omega$

**Note 1:**  $I_{TXO\text{match}}$  refers to the percentage of mismatch in current between  $\text{TXO}^+$  and  $\text{TXO}^-$  referenced to the total output current as defined by:

$$I_{TXO\text{match}} = \frac{I_{\text{TXO}^+} - I_{\text{TXO}^-}}{I_{\text{TXO}^+} + I_{\text{TXO}^-}} \times 100$$

**Note 2:**  $V_{\text{TXO}^+}$  and  $V_{\text{TXO}^-}$  refer to the voltage present at the  $\text{TXO}^+$  and  $\text{TXO}^-$  output pins respectively.

**Note 3:** Refer to Section 1.3 for further description of the TXREF Multiplier (scaling factor).

**Note 4:** Signal Detect turn on and turn off thresholds are measured differentially directly across the RXI $\pm$  inputs.

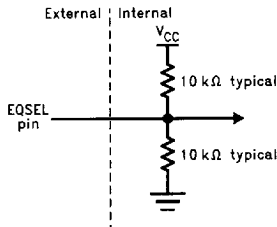

FIGURE 24a. EQSEL 3 Level Input

TL/F/11886-40

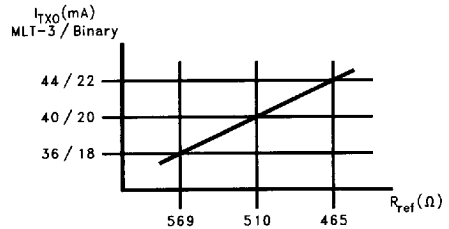

FIGURE 24b. Typical TXO Current vs  $R_{\text{REF}}$

TL/F/11886-41

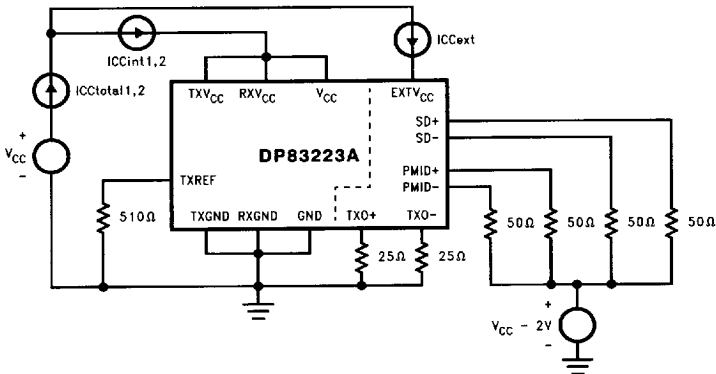

FIGURE 24c. ICc Diagram

TL/F/11886-11

## 5.0 Electrical Characteristics (Continued)

### 5.3 AC ELECTRICAL CHARACTERISTICS $T_A = 25^\circ\text{C}$ , $V_{CC} = 5.0\text{V}$

Symbol	Parameter	Conditions	Min	Typ	Max	Units
$t_{TXr/f1}$	TXO Rise/Fall (10%–90%)	ENCSEL = 1, <i>Figure 25</i>		2.2		ns
$t_{TXr/f2}$	TXO Rise/Fall (10%–90%)	ENCSEL = 0, <i>Figure 26</i>		2.2		ns
$t_{TLH}$	PMID Rise (20%–80%)	LBEN = 1, <i>Figure 27</i>		1.0		ns
$t_{THL}$	PMID Fall (20%–80%)	LBEN = 1, <i>Figure 27</i>		1.0		ns
$t_{TXpd1}$	PMRD/TXO Prop Delay	ENCSEL = 1, <i>Figure 25</i>		TBD		ns
$t_{TXpd2}$	PMRD/TXO Prop Delay	ENCSEL = 0, <i>Figure 26</i>		TBD		ns
$t_{RXpd1}$	RXI/PMID Prop Delay	ENCSEL = 1 (Note 1) <i>Figure 27</i>		TBD		ns
$t_{RXpd2}$	RXI/PMID Prop Delay	ENCSEL = 0 (Note 2) <i>Figure 28</i>		TBD		ns
$t_{LBpd}$	PMRD/PMID Prop Delay	LBEN = 1, <i>Figure 31</i>		TBD		ns
$t_{LBon\_pmid}$	LBEN On to PMID	LBEN = 1, RXI Not Switching, <i>Figure 29</i>		TBD		ns
$t_{LBoff\_pmid}$	LBEN Off to PMID	LBEN = 0, RXI Not Switching, <i>Figure 29</i>		TBD		ns
$t_{LBon\_txo}$	LBEN On to TXO Balance	LBEN = 1, <i>Figure 29</i>		TBD		ns
$t_{LBoff\_txo}$	LBEN Off to TXO Balance	LBEN = 0, <i>Figure 29</i>		TBD		ns
$t_{LBon\_sd}$	LBEN On to SD+ High	LBEN = 1, <i>Figure 29</i>		TBD		ns
$t_{LBon\_sd}$	LBEN On to SD+ Normal	LBEN = 0, <i>Figure 29</i>		TBD		ns
$t_{OEon\_pmid}$	$\overline{OE}$ On to PMID Active	<i>Figure 30</i>		TBD		ns
$t_{OEoff\_pmid}$	$\overline{OE}$ Off to PMID Inactive	<i>Figure 30</i>		TBD		ns
$t_{OEon\_txo}$	$\overline{OE}$ On to TXO Active	<i>Figure 30</i>		TBD		ns
$t_{OEoff\_txo}$	$\overline{OE}$ Off to TXO TRI-STATE	<i>Figure 30</i>		TBD		ns
$t_{OEon\_sd}$	$\overline{OE}$ On to SD Active	<i>Figure 30</i>		TBD		ns
$t_{OEoff\_sd}$	$\overline{OE}$ Off to SD+ Forced High	<i>Figure 30</i>		TBD		ns
$t_{SDon1}$	RXI Data to SD High	ENCSEL = 1 (Note 3) <i>Figure 32</i>		TBD		ns
$t_{SDon2}$	RXI Data to SD High	ENCSEL = 0 (Note 4) <i>Figure 33</i>		TBD		ns
$t_{SDoff1}$	RXI Quiet to SD Low	ENCSEL = 1 (Note 3) <i>Figure 32</i>		TBD		ns
$t_{SDoff2}$	RXI Quiet to SD Low	ENCSEL = 0 (Note 4) <i>Figure 33</i>		TBD		ns
$t_{jTX1}$	TX pk Total Jitter	ENCSEL = 1 (Note 5)		TBD		ps
$t_{jTX2}$	TX pk Total Jitter	ENCSEL = 0 (Note 5)		TBD		ps
$t_{jRX1}$	RX pk Total Jitter	ENCSEL = 1 (Note 6)		TBD		ps
$t_{jRX2}$	RX pk Total Jitter	ENCSEL = 0 (Note 6)		TBD		ps
Mbps <sub>Max1</sub>	Maximum Binary Data Rate	ENCSEL = 1		155		Mbps
Mbps <sub>Max2</sub>	Maximum MLT-3 Data Rate	ENCSEL = 0		125		Mbps

**Note 1:**  $t_{RXpd1}$  RXI to PMID timing is measured by applying a 1 Vp-p 62.5 MHz square wave to the RXI $\pm$  inputs with EQSEL floating.

**Note 2:**  $t_{RXpd2}$  RXI to PMID timing is measured by applying a 1.5 Vp-p 62.5 MHz MLT-3 IDLE to the RXI $\pm$  input with EQSEL floating.

**Note 3:** Signal Detect turn on and turn off times are measured using an MTL-3 2 Vp-p scrambled halt bit stream over a length of Category 5 UTP cable  $\leq$  100 Meters with adaptive equalization enabled.

**Note 4:** Signal Detect turn on and turn off times are measured using a binary 1 Vp-p  $2^{23}$  pseudo random bit stream over a length of Category 5 UTP cable  $\leq$  100 Meters with adaptive equalization enabled.

**Note 5:** TX Jitter measurements are made differentially at the TXO $\pm$  current outputs using a scrambled HALT bit stream for MLT-3 mode and PRBS  $2^{23}$  for binary mode. All measurements are referenced to the original transmit clock.

**Note 6:** RX Jitter measurements are made differentially at the PMID $\pm$  PECL outputs using a scrambled HALT bit stream for MTL-3 mode and PRBS  $2^{23}$  for binary mode. This test includes data transmission over a 100M Cat-5 cable plant comprised of 90M of horizontal wiring, two 5M lengths of vertical wiring, two 110 punchdown blocks and 2 RJ45-8 wall jacks. All measurements are referenced to the original transmit clock.

## 5.0 Electrical Characteristics (Continued)

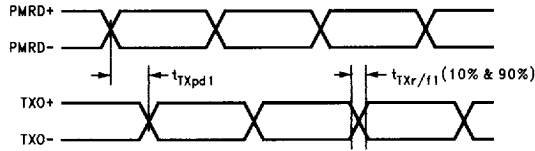

FIGURE 25. TXO Timing (binary)

TL/F/11886-42

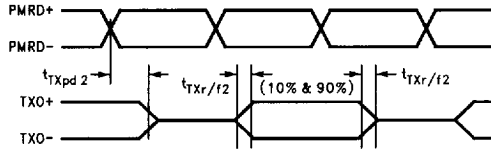

FIGURE 26. TXO Timing (MLT-3)

TL/F/11886-43

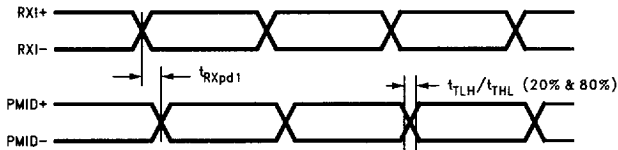

FIGURE 27. PMID Timing (Binary RXI to PMID)

TL/F/11886-15

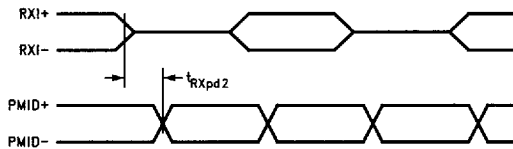
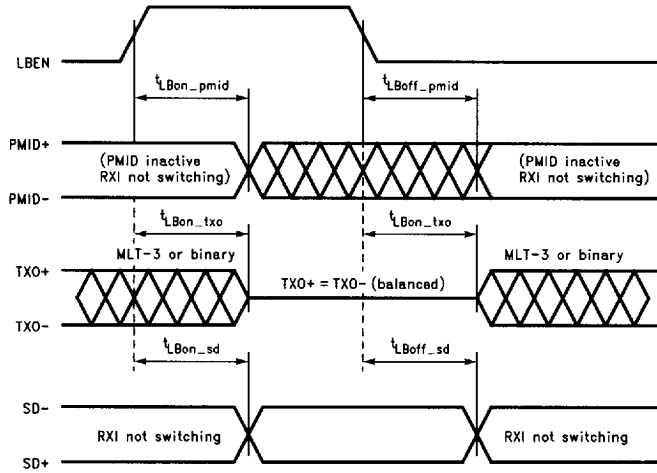

FIGURE 28. PMID Timing (MLT-3 RXI to PMID)

TL/F/11886-44

## 5.0 Electrical Characteristics (Continued)



**FIGURE 29. Loopback Timing**

TL/F/11886-45

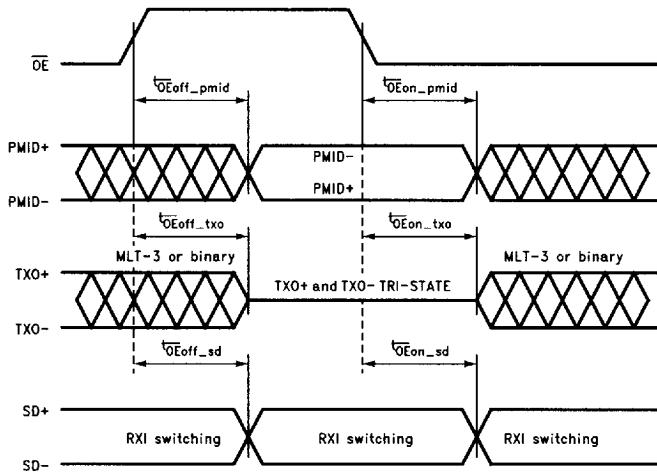

**FIGURE 30. Output Enable Timing**

TL/F/11886-46

## 5.0 Electrical Characteristics (Continued)

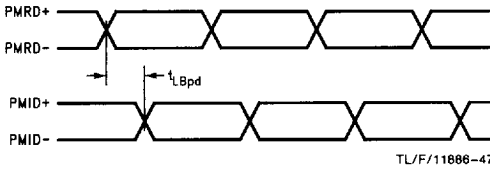

FIGURE 31. PMID Timing (Loopback)

TL/F/11886-47

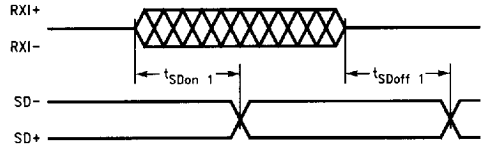

FIGURE 32. Signal Detect Timing (Binary RXI to SD)

TL/F/11886-48

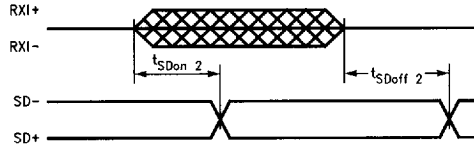
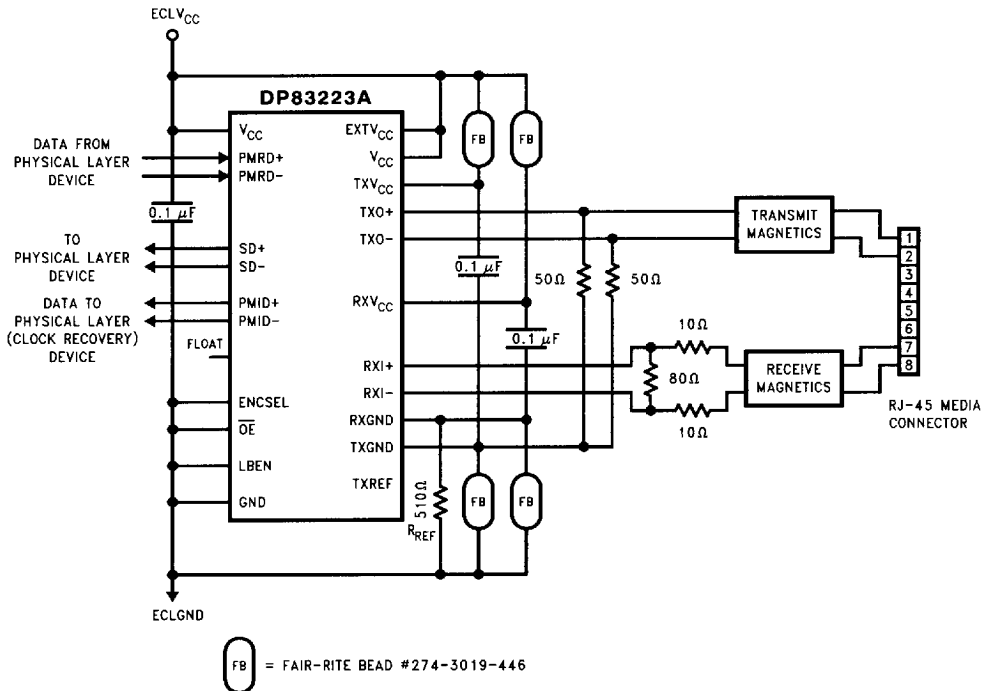

FIGURE 33. Signal Detect Timing (MLT-3 RXI to SD)

TL/F/11886-49



The PMRD, SD and PMID 100K ECL differential signal must be terminated into a standard ECL load of  $50\Omega$  to  $V_{CC}$  minus 2.0V or equivalent; i.e., Thevenin of  $130\Omega$  to GND accompanied by  $82\Omega$  to  $V_{CC}$ .

TL/F/11886-16

FIGURE 34. Typical Schematic for MTL-3 Signalling over Cat-5 UTP Cable

**Physical Dimensions** inches (millimeters)

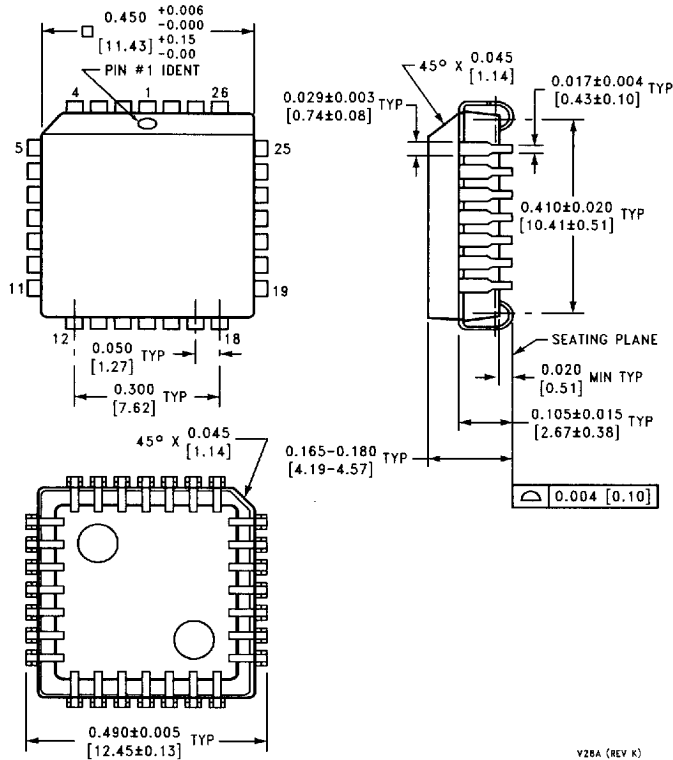

V28A (REV K)

**Plastic Lead Chip Carrier (V)  
Order Number DP83223AV  
NS Package Number V28A**

**LIFE SUPPORT POLICY**

NATIONAL'S PRODUCTS ARE NOT AUTHORIZED FOR USE AS CRITICAL COMPONENTS IN LIFE SUPPORT DEVICES OR SYSTEMS WITHOUT THE EXPRESS WRITTEN APPROVAL OF THE PRESIDENT OF NATIONAL SEMICONDUCTOR CORPORATION. As used herein:

1. Life support devices or systems are devices or systems which, (a) are intended for surgical implant into the body, or (b) support or sustain life, and whose failure to perform, when properly used in accordance with instructions for use provided in the labeling, can be reasonably expected to result in a significant injury to the user.
2. A critical component is any component of a life support device or system whose failure to perform can be reasonably expected to cause the failure of the life support device or system, or to affect its safety or effectiveness.



**National Semiconductor Corporation**  
2900 Semiconductor Drive  
P.O. Box 58080  
Santa Clara, CA 95052-8080  
Tel: (800) 272-9959  
TWX: (910) 338-9240

**National Semiconductor GmbH**  
Industriestrasse 10  
D-82256 Furstenfeldbruck  
Germany  
Tel: (0-81-41) 103-0  
Telex: 527849  
Fax: (0-81-41) 10-35-06

**National Semiconductor Japan Ltd.**  
Sumitomo Chemical Engineering Center  
Bldg. 7F  
1-7-1, Nakase, Mihama-Ku  
Chiba-City,  
Chiba Prefecture 261  
Tel: (043) 299-2300  
Fax: (043) 299-2500

**National Semiconductor Hong Kong Ltd.**  
13th Floor, Straight Block  
Ocean Centre, 5 Canton Rd.  
Tsimshatsui, Kowloon  
Hong Kong  
Tel: (852) 737-1600  
Telex: 51282 NSHKL  
Fax: (852) 736-8960

**National Semiconductores Do Brazil Ltda.**  
Rua Deputado Lacerda Franco  
120-3A  
Sao Paulo-SP  
Brazil 05418-000  
Tel: (55-11) 212-5066  
Telex: 391-1131931 NSBR BR  
Fax: (55-11) 212-1181

**National Semiconductor (Australia) Pty, Ltd.**  
16 Business Park Dr.  
Notting Hill, VIC 3168  
Australia  
Tel: (3) 558-9999  
Fax: (3) 558-9998

National does not assume any responsibility for use of any circuitry described, no circuit patent licenses are implied and National reserves the right at any time without notice.

46319

19