

DM54S138/DM74S138, DM54S139/DM74S139 Decoders/Demultiplexers

General Description

These Schottky-clamped circuits are designed to be used in high-performance memory-decoding or data-routing applications, requiring very short propagation delay times. In high-performance memory systems these decoders can be used to minimize the effects of system decoding. When used with high-speed memories, the delay times of these decoders are usually less than the typical access time of the memory. This means that the effective system delay introduced by the decoder is negligible.

The S138 decodes one-of-eight lines, based upon the conditions at the three binary select inputs and the three enable inputs. Two active-low and one active-high enable inputs reduce the need for external gates or inverters when expanding. A 24-line decoder can be implemented with no external inverters, and a 32-line decoder requires only one inverter. An enable input can be used as a data input for demultiplexing applications.

The S139 comprises two separate two-line-to-four-line decoders in a single package. The active-low enable input can be used as a data line in demultiplexing applications.

All of these decoders/demultiplexers feature fully buffered inputs, presenting only one normalized load to its driving circuit. All inputs are clamped with high-performance Schottky diodes to suppress line-ringing and simplify system design.

Features

- Designed specifically for high speed:
 - Memory decoders
 - Data transmission systems
- S138 3-to-8-line decoders incorporates 3 enable inputs to simplify cascading and/or data reception
- S139 contains two fully independent 2-to-4-line decoders/demultiplexers
- Schottky clamped for high performance
- Typical propagation delay time (3 levels of logic)
 - S138 8 ns
 - S139 7.5 ns
- Typical power dissipation
 - S138 245 mW
 - S139 300 mW

Connection Diagrams

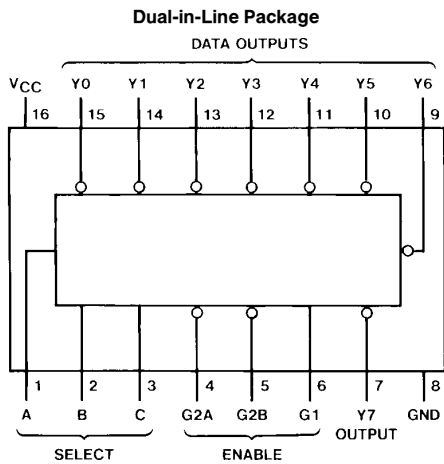

TL/F/6466-1

Order Number DM54S138J, DM54S139J, DM54S138W, DM54139W, DM74S138N or DM74S139N
See NS Package Number J16A, N16E or W16A

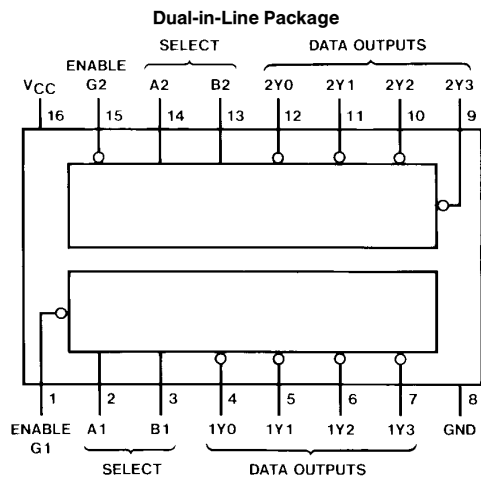

TL/F/6466-2

Absolute Maximum Ratings (Note)

If Military/Aerospace specified devices are required, please contact the National Semiconductor Sales Office/Distributors for availability and specifications.

Supply Voltage	7V
Input Voltage	5.5V
Operating Free Air Temperature Range	
DM54S	−55° C to +125° C
DM74S	0° C to +70° C
Storage Temperature Range	−65° C to +150° C

Note: The "Absolute Maximum Ratings" are those values beyond which the safety of the device cannot be guaranteed. The device should not be operated at these limits. The parametric values defined in the "Electrical Characteristics" table are not guaranteed at the absolute maximum ratings. The "Recommended Operating Conditions" table will define the conditions for actual device operation.

Recommended Operating Conditions

Symbol	Parameter	DM54S138,S139			DM74S138,S139			Units
		Min	Nom	Max	Min	Nom	Max	
V _{CC}	Supply Voltage	4.5	5	5.5	4.75	5	5.25	V
V _{IH}	High Level Input Voltage	2			2			V
V _{IL}	Low Level Input Voltage			0.8			0.8	V
I _{OH}	High Level Output Current			−1			−1	mA
I _{OL}	Low Level Output Current			20			20	mA
T _A	Free Air Operating Temperature	−55		125	0		70	°C

Electrical Characteristics over recommended operating free air temperature (unless otherwise noted)

Symbol	Parameter	Conditions	Min	Typ (Note 1)	Max	Units
V _I	Input Clamp Voltage	V _{CC} = Min, I _I = −18 mA			−1.2	V
V _{OH}	High Level Output Voltage	V _{CC} = Min, I _{OH} = Max V _{IL} = Max, V _{IH} = Min	DM54	2.5	3.4	V
			DM74	2.7	3.4	
V _{OL}	Low Level Output Voltage	V _{CC} = Min, I _{OL} = Max V _{IH} = Min, V _{IL} = Max			0.5	V
I _I	Input Current @ Max Input Voltage	V _{CC} = Max, V _I = 5.5V			1	mA
I _{IH}	High Level Input Current	V _{CC} = Max, V _I = 2.7V			50	μA
I _{IL}	Low Level Input Current	V _{CC} = Max, V _I = 0.5V			−2	mA
I _{OS}	Short Circuit Output Current	V _{CC} = Max (Note 2)	DM54	−40	−100	mA
			DM74	−40	−100	
I _{CC}	Supply Current (S138)	V _{CC} = Max (Note 3)		49	74	mA
	Supply Current (S139)	V _{CC} = Max (Note 3)		60	90	mA

Note 1: All typicals are at V_{CC} = 5V, T_A = 25°C.

Note 2: Not more than one output should be shorted at a time, and the duration should not exceed one second.

Note 3: I_{CC} is measured with all outputs enabled and open.

'S138 Switching Characteristics

at $V_{CC} = 5V$ and $T_A = 25^\circ C$ (See Section 1 for Test Waveforms and Output Load)

Symbol	Parameter	From (Input) to (Output)	Levels of Delay	$R_L = 280\Omega$				Units
				$C_L = 15\text{ pF}$		$C_L = 50\text{ pF}$		
				Min	Max	Min	Max	
t_{PLH}	Propagation Delay Time Low to High Level Output	Select to Output	2		7		9	ns
t_{PHL}	Propagation Delay Time High to Low Level Output	Select to Output	2		10.5		14	ns
t_{PLH}	Propagation Delay Time Low to High Level Output	Select to Output	3		12		14	ns
t_{PHL}	Propagation Delay Time High to Low Level Output	Select to Output	3		12		15	ns
t_{PLH}	Propagation Delay Time Low to High Level Output	Enable to Output	2		8		10	ns
t_{PHL}	Propagation Delay Time High to Low Level Output	Enable to Output	2		11		14	ns
t_{PLH}	Propagation Delay Time Low to High Level Output	Enable to Output	3		11		13	ns
t_{PHL}	Propagation Delay Time High to Low Level Output	Enable to Output	3		11		14	ns

'S139 Switching Characteristics

at $V_{CC} = 5V$ and $T_A = 25^\circ C$ (See Section 1 for Test Waveforms and Output Load)

Symbol	Parameter	From (Input) to (Output)	Levels of Delay	$R_L = 280\Omega$				Units
				$C_L = 15\text{ pF}$		$C_L = 50\text{ pF}$		
				Min	Max	Min	Max	
t_{PLH}	Propagation Delay Time Low to High Level Output	Select to Output	2		7.5		10	ns
t_{PHL}	Propagation Delay Time High to Low Level Output	Select to Output	2		10		13	ns
t_{PLH}	Propagation Delay Time Low to High Level Output	Select to Output	3		12		13	ns
t_{PHL}	Propagation Delay Time High to Low Level Output	Select to Output	3		12		15	ns
t_{PLH}	Propagation Delay Time Low to High Level Output	Enable to Output	2		8		10	ns
t_{PHL}	Propagation Delay Time High to Low Level Output	Enable to Output	2		10		13	ns

Function Tables

S138

Inputs					Outputs							
Enable		Select			Y0	Y1	Y2	Y3	Y4	Y5	Y6	Y7
G1	G2*	C	B	A								
X	H	X	X	X	H	H	H	H	H	H	H	H
L	X	X	X	X	H	H	H	H	H	H	H	H
H	L	L	L	L	H	H	H	H	H	H	H	H
H	L	L	L	H	H	L	H	H	H	H	H	H
H	L	L	H	L	H	H	L	H	H	H	H	H
H	L	L	H	H	H	H	L	H	H	H	H	H
H	L	H	L	L	H	H	H	L	H	H	H	H
H	L	H	L	H	H	H	H	L	H	H	H	H
H	L	H	H	L	H	H	H	H	L	H	H	H
H	L	H	H	H	H	H	H	H	H	L	H	H
H	L	H	H	H	H	H	H	H	H	H	L	H

* G2 = G2A + G2B

H = high level, L = low level, X = don't care (either low or high logic level)

S139

Inputs			Outputs			
Enable	Select		Y0	Y1	Y2	Y3
G	B	A				
H	X	X	H	H	H	H
L	L	L	L	H	H	H
L	L	H	H	L	H	H
L	H	L	H	H	L	H
L	H	H	H	H	H	L

H = high level, L = low level, X = don't care (either low or high logic level)

Logic Diagrams

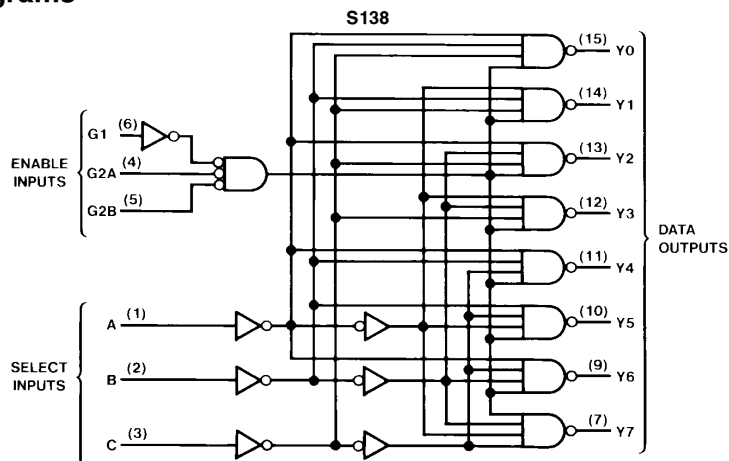

TL/F/6466-3

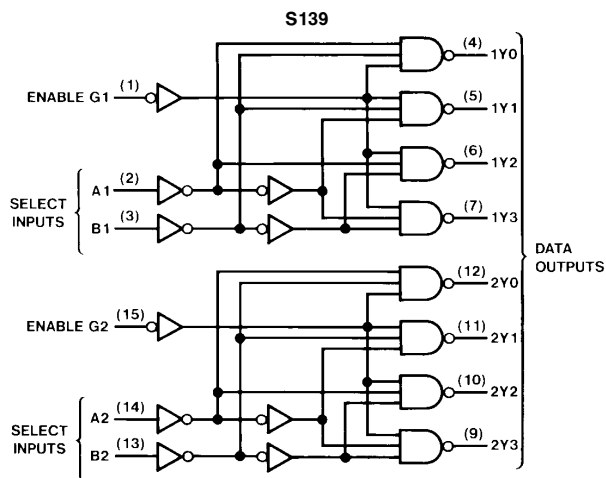

TL/F/6466-4

Physical Dimensions inches (millimeters)

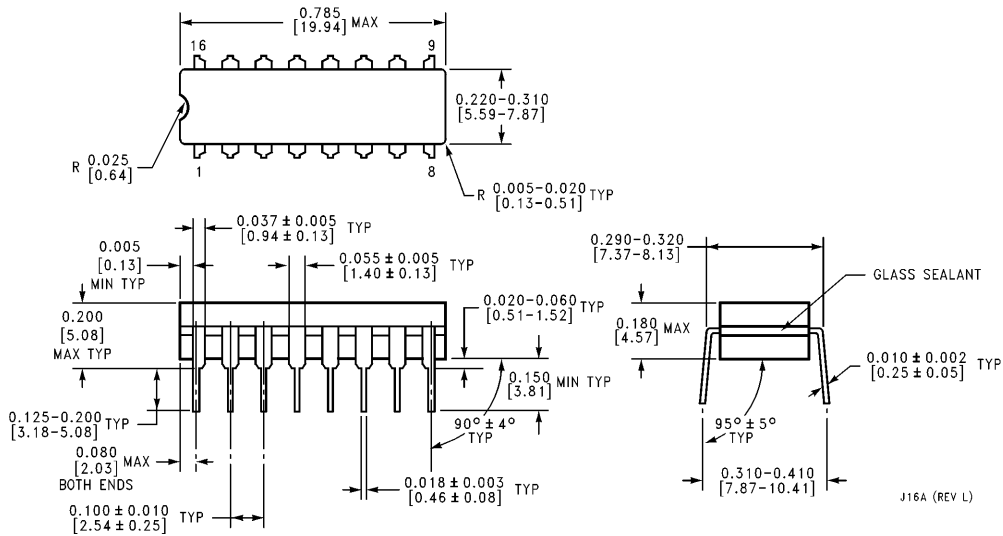

16-Lead Ceramic Dual-In-Line Package (J)
Order Number DM54S138J or DM54S139J
NS Package Number J16A

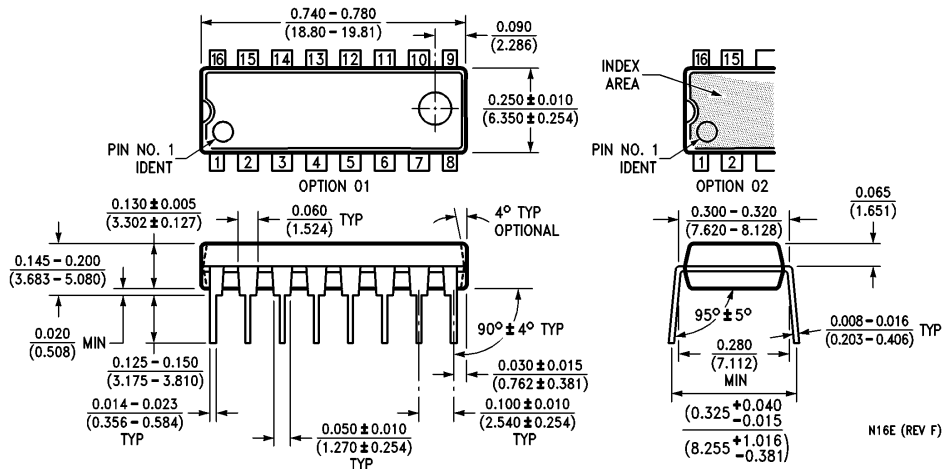

16-Lead Molded Dual-In-Line Package (N)
Order Number DM74S138N or DM74S139N
NS Package Number N16E

Physical Dimensions inches (millimeters) (Continued)

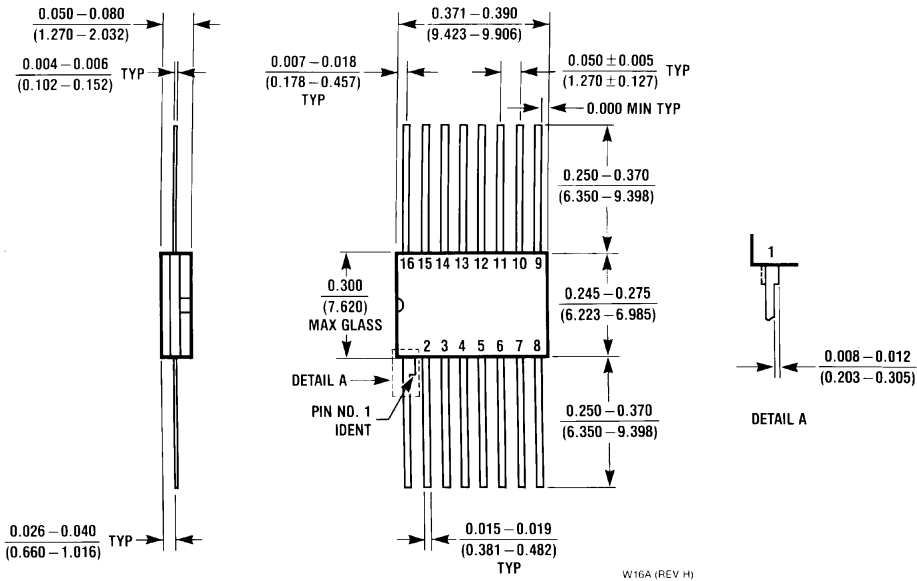

16-Lead Ceramic Flat Package (W)
Order Number DM54S138W or DM54S139W
NS Package Number W16A

W16A (REV. H)

LIFE SUPPORT POLICY

NATIONAL'S PRODUCTS ARE NOT AUTHORIZED FOR USE AS CRITICAL COMPONENTS IN LIFE SUPPORT DEVICES OR SYSTEMS WITHOUT THE EXPRESS WRITTEN APPROVAL OF THE PRESIDENT OF NATIONAL SEMICONDUCTOR CORPORATION. As used herein:

1. Life support devices or systems are devices or systems which, (a) are intended for surgical implant into the body, or (b) support or sustain life, and whose failure to perform, when properly used in accordance with instructions for use provided in the labeling, can be reasonably expected to result in a significant injury to the user.
2. A critical component is any component of a life support device or system whose failure to perform can be reasonably expected to cause the failure of the life support device or system, or to affect its safety or effectiveness.



National Semiconductor Corporation
 1111 West Bardin Road
 Arlington, TX 76017
 Tel: 1(800) 272-9959
 Fax: 1(800) 737-7018

National Semiconductor Europe
 Fax: (+49) 0-180-530 85 86
 Email: onjwge@tevm2.nsc.com
 Deutsch Tel: (+49) 0-180-530 85 85
 English Tel: (+49) 0-180-532 78 32
 Français Tel: (+49) 0-180-532 93 58
 Italiano Tel: (+49) 0-180-534 16 80

National Semiconductor Hong Kong Ltd.
 19th Floor, Straight Block,
 Ocean Centre, 5 Canton Rd.
 Tsimshatsui, Kowloon
 Hong Kong
 Tel: (852) 2737-1600
 Fax: (852) 2736-9960

National Semiconductor Japan Ltd.
 Tel: 81-043-299-2309
 Fax: 81-043-299-2408

National does not assume any responsibility for use of any circuitry described, no circuit patent licenses are implied and National reserves the right at any time without notice to change said circuitry and specifications.