

## 54LS157/DM54LS157/DM74LS157, 54LS158/DM54LS158/DM74LS158 Quad 2-Line to 1-Line Data Selectors/Multiplexers

### General Description

These data selectors/multiplexers contain inverters and drivers to supply full on-chip data selection to the four output gates. A separate strobe input is provided. A 4-bit word is selected from one of two sources and is routed to the four outputs. The LS157 presents true data whereas the LS158 presents inverted data to minimize propagation delay time.

### Applications

- Expand any data input point
- Multiplex dual data buses
- Generate four functions of two variables (one variable is common)
- Source programmable counters

### Features

- Buffered inputs and outputs
- Typical Propagation Time  
LS157 9 ns  
LS158 7 ns
- Typical Power Dissipation  
LS157 49 mW  
LS158 24 mW
- Alternate Military/Aerospace device (54LS157, 54LS158) is available. Contact a National Semiconductor Sales Office/Distributor for specifications.

### Connection Diagrams

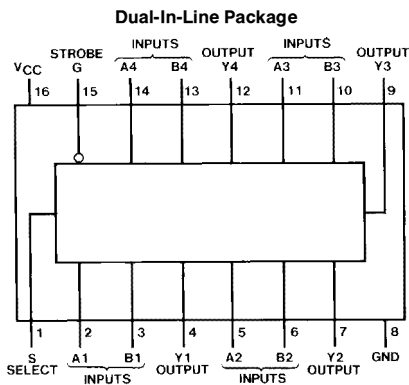

TL/F/6396-1

Order Number 54LS157DMQB, 54LS157FMQB,  
54LS157LMQB, DM54LS157J, DM54LS157W,  
DM74LS157M or DM74LS157N  
See NS Package Number E20A, J16A,  
M16A, N16E or W16A

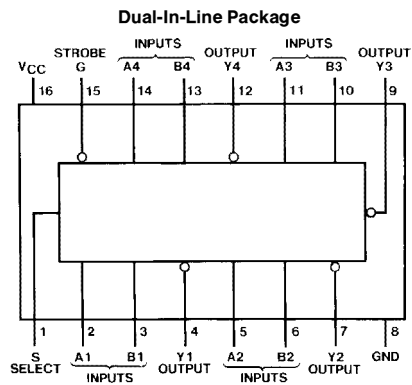

TL/F/6396-2

Order Number 54LS158DMQB, 54LS158FMQB,  
54LS158LMQB, DM54LS158J, DM54LS158W,  
DM74LS158M or DM74LS158N  
See NS Package Number E20A, J16A,  
M16A, N16E or W16A

### Function Table

Inputs				Output Y	
Strobe	Select	A	B	LS157	LS158
H	X	X	X	L	H
L	L	L	X	L	H
L	L	H	X	H	L
L	H	X	L	L	H
L	H	X	H	H	L

H = High Level, L = Low Level, X = Don't Care

54LS157/DM54LS157/DM74LS157, 54LS158/DM54LS158/DM74LS158  
Quad 2-Line to 1-Line Data Selectors/Multiplexers

### Absolute Maximum Ratings (Note)

If Military/Aerospace specified devices are required, please contact the National Semiconductor Sales Office/Distributors for availability and specifications.

Supply Voltage	7V
Input Voltage	7V
Operating Free Air Temperature Range	
DM54LS and 54LS	-55°C to +125°C
DM74LS	0°C to +70°C
Storage Temperature Range	-65°C to +150°C

Note: The "Absolute Maximum Ratings" are those values beyond which the safety of the device cannot be guaranteed. The device should not be operated at these limits. The parametric values defined in the "Electrical Characteristics" table are not guaranteed at the absolute maximum ratings. The "Recommended Operating Conditions" table will define the conditions for actual device operation.

### Recommended Operating Conditions

Symbol	Parameter	DM54LS157			DM74LS157			Units
		Min	Nom	Max	Min	Nom	Max	
V <sub>CC</sub>	Supply Voltage	4.5	5	5.5	4.75	5	5.25	V
V <sub>IH</sub>	High Level Input Voltage	2			2			V
V <sub>IL</sub>	Low Level Input Voltage			0.7			0.8	V
I <sub>OH</sub>	High Level Output Current			-0.4			-0.4	mA
I <sub>OL</sub>	Low Level Output Current			4			8	mA
T <sub>A</sub>	Free Air Operating Temperature	-55		125	0		70	°C

### 'LS157 Electrical Characteristics

over recommended operating free air temperature range (unless otherwise noted)

Symbol	Parameter	Conditions	Min	Typ (Note 1)	Max	Units
V <sub>I</sub>	Input Clamp Voltage	V <sub>CC</sub> = Min, I <sub>I</sub> = -18 mA			-1.5	V
V <sub>OH</sub>	High Level Output Voltage	V <sub>CC</sub> = Min, I <sub>OH</sub> = Max V <sub>IL</sub> = Max, V <sub>IH</sub> = Min	DM54	2.5	3.4	V
			DM74	2.7	3.4	
V <sub>OL</sub>	Low Level Output Voltage	V <sub>CC</sub> = Min, I <sub>OL</sub> = Max V <sub>IL</sub> = Max, V <sub>IH</sub> = Min	DM54		0.25	V
			DM74		0.35	
		I <sub>OL</sub> = 4 mA, V <sub>CC</sub> = Min	DM74		0.25	0.4
I <sub>I</sub>	Input Current @ Max Input Voltage	V <sub>CC</sub> = Max V <sub>I</sub> = 7V	S or G		0.2	mA
			A or B		0.1	
I <sub>IH</sub>	High Level Input Current	V <sub>CC</sub> = Max V <sub>I</sub> = 2.7V	S or G		40	μA
			A or B		20	
I <sub>IL</sub>	Low Level Input Current	V <sub>CC</sub> = Max V <sub>I</sub> = 0.4V	S or G		-0.8	mA
			A or B		-0.4	
I <sub>OS</sub>	Short Circuit Output Current	V <sub>CC</sub> = Max (Note 2)	DM54	-20	-100	mA
			DM74	-20	-100	
I <sub>CC</sub>	Supply Current	V <sub>CC</sub> = Max (Note 3)		9.7	16	mA

Note 1: All typicals are at V<sub>CC</sub> = 5V, T<sub>A</sub> = 25°C.

Note 2: Not more than one output should be shorted at a time, and the duration should not exceed one second.

Note 3: I<sub>CC</sub> is measured with 4.5V applied to all inputs and all outputs open.

## 'LS157 Switching Characteristics

at  $V_{CC} = 5V$  and  $T_A = 25^\circ C$  (See Section 1 for Test Waveforms and Output Load)

Symbol	Parameter	From (Input) To (Output)	$R_L = 2\text{ k}\Omega$				Units
			$C_L = 15\text{ pF}$		$C_L = 50\text{ pF}$		
			Min	Max	Min	Max	
$t_{PLH}$	Propagation Delay Time Low to High Level Output	Data to Y		14		18	ns
$t_{PHL}$	Propagation Delay Time High to Low Level Output	Data to Y		14		23	ns
$t_{PLH}$	Propagation Delay Time Low to High Level Output	Strobe to Y		20		24	ns
$t_{PHL}$	Propagation Delay Time High to Low Level Output	Strobe to Y		21		30	ns
$t_{PLH}$	Propagation Delay Time Low to High Level Output	Select to Y		23		28	ns
$t_{PHL}$	Propagation Delay Time High to Low Level Output	Select to Y		27		32	ns

## Recommended Operating Conditions

Symbol	Parameter	DM54LS158			DM74LS158			Units
		Min	Nom	Max	Min	Nom	Max	
$V_{CC}$	Supply Voltage	4.5	5	5.5	4.75	5	5.25	V
$V_{IH}$	High Level Input Voltage	2			2			V
$V_{IL}$	Low Level Input Voltage			0.7			0.8	V
$I_{OH}$	High Level Output Current			-0.4			-0.4	mA
$I_{OL}$	Low Level Output Current			4			8	mA
$T_A$	Free Air Operating Temperature	-55		125	0		70	$^\circ C$

## 'LS158 Electrical Characteristics

over recommended operating free air temperature range (unless otherwise noted)

Symbol	Parameter	Conditions	Min	Typ (Note 1)	Max	Units
$V_I$	Input Clamp Voltage	$V_{CC} = \text{Min}, I_I = -18\text{ mA}$			-1.5	V
$V_{OH}$	High Level Output Voltage	$V_{CC} = \text{Min}, I_{OH} = \text{Max}$ $V_{IL} = \text{Max}, V_{IH} = \text{Min}$	DM54	2.5	3.4	V
			DM74	2.7	3.4	
$V_{OL}$	Low Level Output Voltage	$V_{CC} = \text{Min}, I_{OL} = \text{Max}$ $V_{IL} = \text{Max}, V_{IH} = \text{Min}$	DM54		0.25	V
			DM74		0.35	
			DM74		0.25	
$I_I$	Input Current @ Max Input Voltage	$V_{CC} = \text{Max}$ $V_I = 7V$	S or G		0.2	mA
			A or B		0.1	
$I_{IH}$	High Level Input Current	$V_{CC} = \text{Max}$ $V_I = 2.7V$	S or G		40	$\mu A$
			A or B		20	
$I_{IL}$	Low Level Input Current	$V_{CC} = \text{Max}$ $V_I = 0.4V$	S or G		-0.8	mA
			A or B		-0.4	
$I_{OS}$	Short Circuit Output Current	$V_{CC} = \text{Max}$ (Note 2)	DM54	-20	-100	mA
			DM74	-20	-100	
$I_{CC}$	Supply Current	$V_{CC} = \text{Max}$ (Note 3)		4.8	8	mA

**Note 1:** All typicals are at  $V_{CC} = 5V, T_A = 25^\circ C$ .

**Note 2:** Not more than one output should be shorted at a time, and the duration should not exceed one second.

**Note 3:**  $I_{CC}$  is measured with 4.5V applied to all inputs and all outputs open.

## 'LS158 Switching Characteristics

at  $V_{CC} = 5V$  and  $T_A = 25^\circ C$  (See Section 1 for Test Waveforms and Output Load)

Symbol	Parameter	From (Input) To (Output)	$R_L = 2\text{ k}\Omega$				Units
			$C_L = 15\text{ pF}$		$C_L = 50\text{ pF}$		
			Min	Max	Min	Max	
$t_{PLH}$	Propagation Delay Time Low to High Level Output	Data to Y		12		18	ns
$t_{PHL}$	Propagation Delay Time High to Low Level Output	Data to Y		12		21	ns
$t_{PLH}$	Propagation Delay Time Low to High Level Output	Strobe to Y		17		23	ns
$t_{PHL}$	Propagation Delay Time High to Low Level Output	Strobe to Y		18		28	ns
$t_{PLH}$	Propagation Delay Time Low to High Level Output	Select to Y		20		24	ns
$t_{PHL}$	Propagation Delay Time High to Low Level Output	Select to Y		24		36	ns

## Logic Diagrams

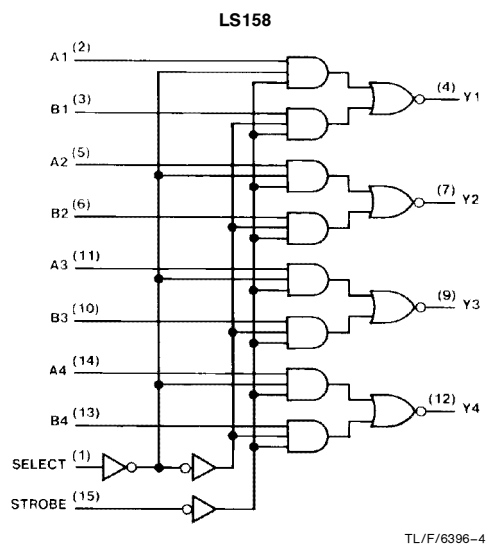
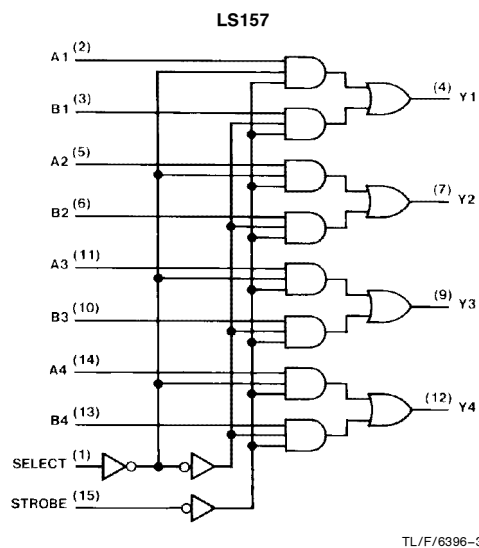

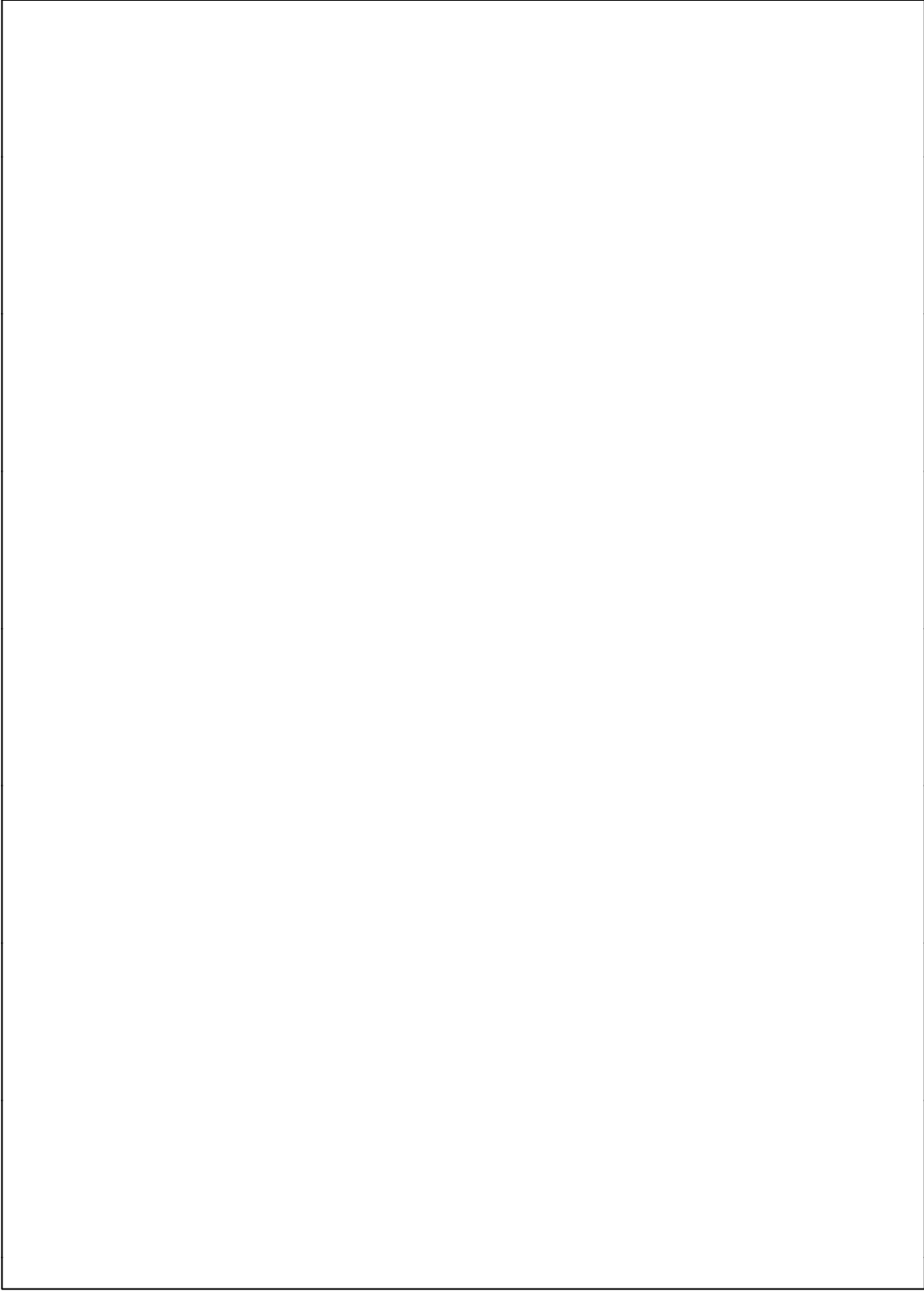

**Physical Dimensions** inches (millimeters)

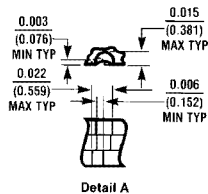
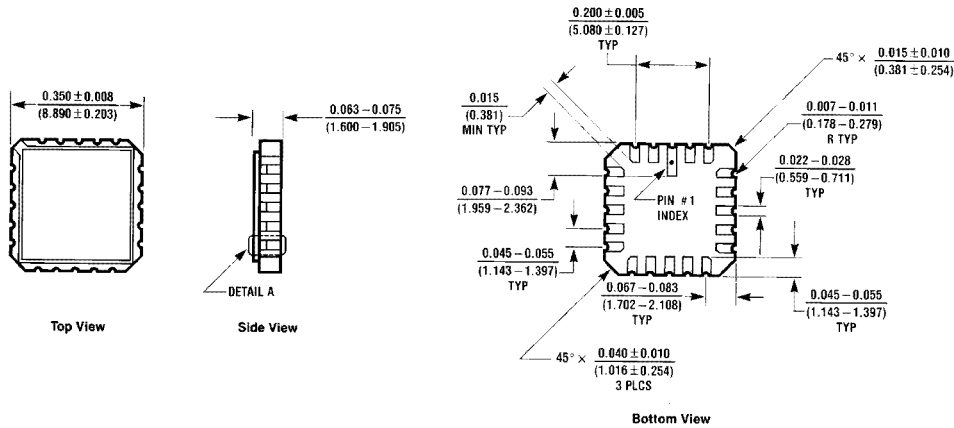

**Ceramic Leadless Chip Carrier Package (E)**  
**Order Number 54LS157LMQB or 54LS158LMQB**  
**NS Package Number E20A**

E20A (REV D)

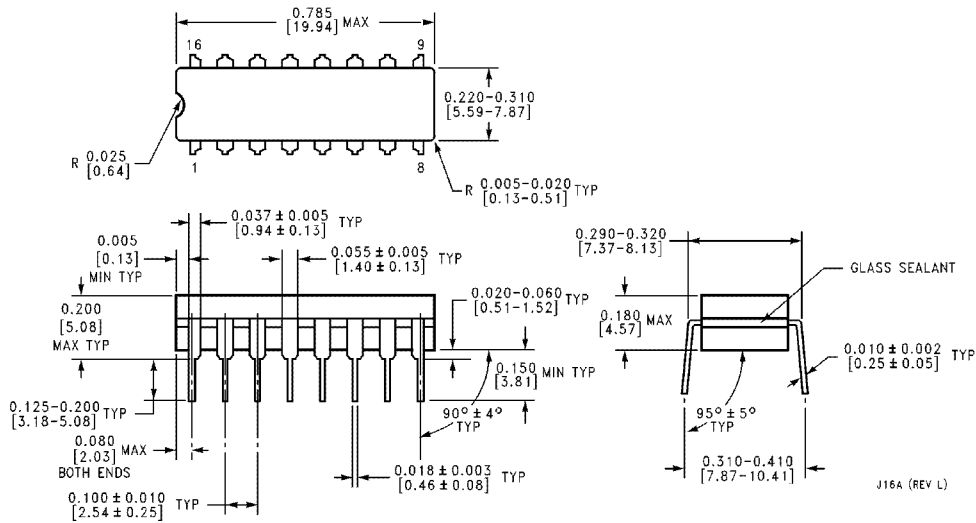

J16A (REV L)

**16-Lead Ceramic Dual-In-Line Package (J)**  
**Order Number 54LS157DMQB, 54LS158DMQB, DM54LS157J or DM54LS158J**  
**NS Package Number J16A**

**Physical Dimensions** inches (millimeters) (Continued)

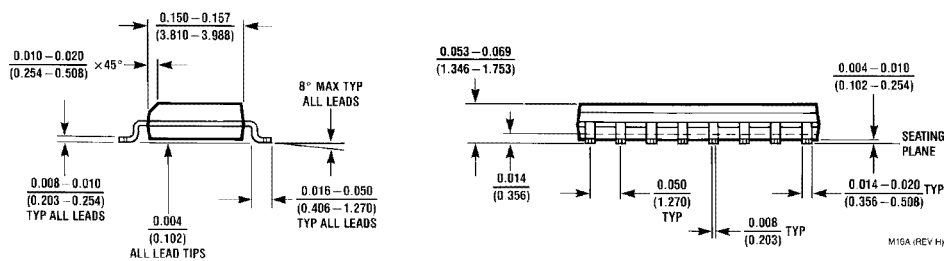
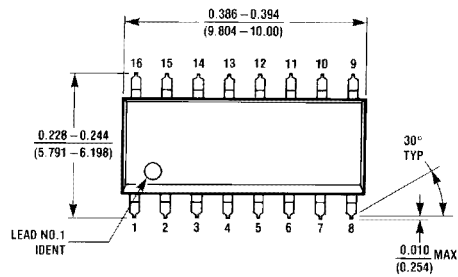

**16-Lead Small Outline Molded Package (M)**  
**Order Number DM74LS157M or DM74LS158M**  
**NS Package Number M16A**

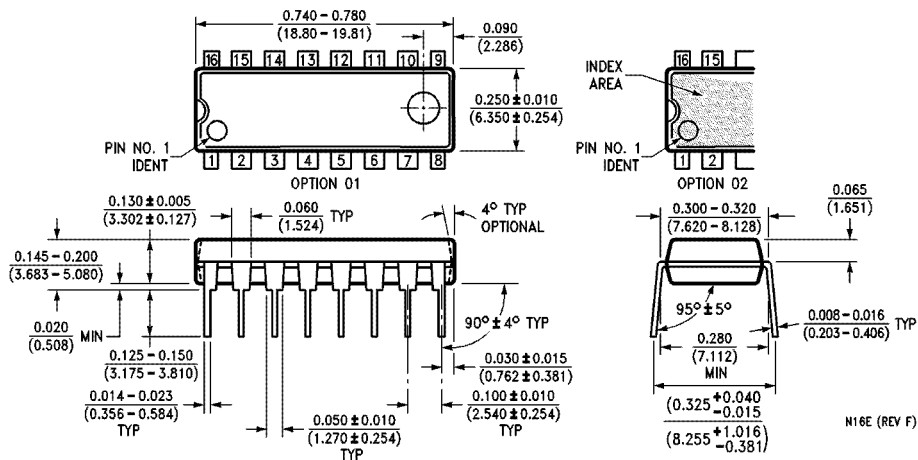

**16-Lead Molded Dual-In-Line Package (N)**  
**Order Number DM74LS157N or DM74LS158N**  
**NS Package Number N16E**

54LS157/DM54LS157/DM74LS157, 54LS158/DM54LS158/DM74LS158 Quad 2-Line to 1-Line Data Selectors/Multiplexers

**Physical Dimensions** inches (millimeters) (Continued)

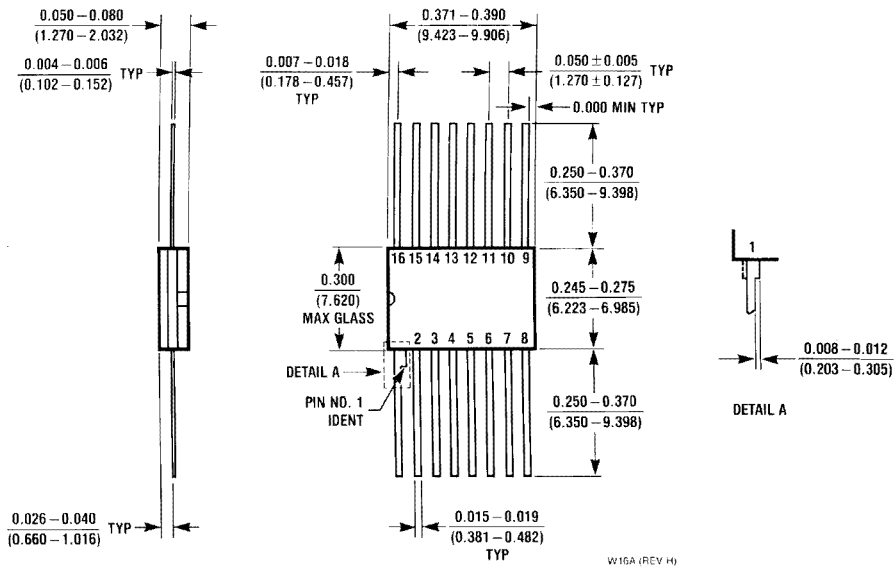

**16-Lead Ceramic Flat Package (W)**  
**Order Number 54LS157FMQB, 54LS158FMQB, DM54LS157W or DM54LS158W**  
**NS Package Number W16A**

**LIFE SUPPORT POLICY**

NATIONAL'S PRODUCTS ARE NOT AUTHORIZED FOR USE AS CRITICAL COMPONENTS IN LIFE SUPPORT DEVICES OR SYSTEMS WITHOUT THE EXPRESS WRITTEN APPROVAL OF THE PRESIDENT OF NATIONAL SEMICONDUCTOR CORPORATION. As used herein:

1. Life support devices or systems are devices or systems which, (a) are intended for surgical implant into the body, or (b) support or sustain life, and whose failure to perform, when properly used in accordance with instructions for use provided in the labeling, can be reasonably expected to result in a significant injury to the user.
2. A critical component is any component of a life support device or system whose failure to perform can be reasonably expected to cause the failure of the life support device or system, or to affect its safety or effectiveness.

 <p><b>National Semiconductor Corporation</b>          1111 West Bardin Road          Arlington, TX 76017          Tel: 1(800) 272-9959          Fax: 1(800) 737-7018</p>	<p><b>National Semiconductor Europe</b>          Fax: (+49) 0-180-530 85 86          Email: cnjwge@tevm2.nsc.com          Deutsch Tel: (+49) 0-180-530 85 85          English Tel: (+49) 0-180-532 78 32          Français Tel: (+49) 0-180-532 93 58          Italiano Tel: (+49) 0-180-534 16 80</p>	<p><b>National Semiconductor Hong Kong Ltd.</b>          13th Floor, Straight Block,          Ocean Centre, 5 Canton Rd.          Tsimshatsui, Kowloon          Hong Kong          Tel: (852) 2737-1600          Fax: (852) 2736-9960</p>	<p><b>National Semiconductor Japan Ltd.</b>          Tel: 81-043-299-2309          Fax: 81-043-299-2408</p>
--	--	---	---

National does not assume any responsibility for use of any circuitry described, no circuit patent licenses are implied and National reserves the right at any time without notice to change said circuitry and specifications.