

DM74ALS74A Dual D Positive-Edge-Triggered Flip-Flop with Preset and Clear

General Description

The 'ALS74A contains two independent positive edge-triggered flip-flops. Each flip-flop has individual D, clock, clear and preset inputs, and also complementary Q and \bar{Q} outputs.

Information at input D is transferred to the Q output on the positive going edge of the clock pulse. Clock triggering occurs at a voltage level of the clock pulse and is not directly related to the transition time of the positive going pulse. When the clock input is at either the high or low level, the D input signal has no effect.

Asynchronous preset and clear inputs will set or clear Q output respectively upon the application of low level signal.

Features

- Switching specifications at 50 pF
- Switching specifications guaranteed over full temperature and V_{CC} range
- Advanced oxide-isolated, ion-implanted Schottky TTL process
- Functionally and pin-for-pin compatible with Schottky and LS TTL counterpart
- Improved AC performance over LS74 at approximately half the power

Connection Diagram

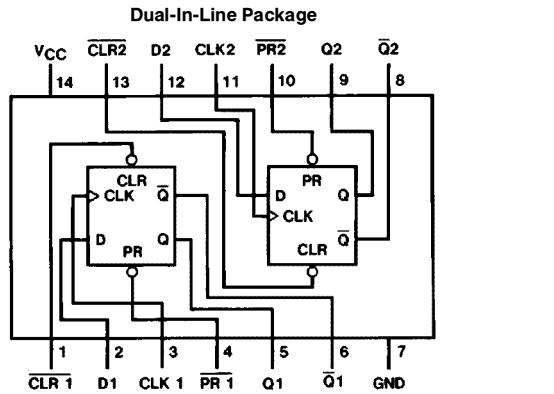

Order Number DM74ALS74AM, DM74ALS74AN or DM74ALS74ASJ
See NS Package Number M14A, M14D or N14A

Function Table

Inputs				Outputs	
\overline{PR}	\overline{CLR}	CLK	D	Q	\bar{Q}
L	H	X	X	H	L
H	L	X	X	L	H
L	L	X	X	H*	H*
H	H	↑	H	H	L
H	H	↑	L	L	H
H	H	L	X	Q_0	\bar{Q}_0

L = Low State, H = High State, X = Don't Care

↑ = Positive Edge Transition

Q_0 = Previous Condition of Q

* = This condition is nonstable; it will not persist when preset and clear inputs return to their inactive (high) level. The output levels in this condition are not guaranteed to meet the V_{OH} specification.

Absolute Maximum Ratings

Supply Voltage	7V
Input Voltage	7V
Operating Free Air Temperature Range	
DM74ALS	0°C to +70°C
Storage Temperature Range	-65°C to +150°C
Typical θ_{JA}	
N Package	87.0°C/W
M Package	117.0°C/W

Note: The "Absolute Maximum Ratings" are those values beyond which the safety of the device cannot be guaranteed. The device should not be operated at these limits. The parametric values defined in the "Electrical Characteristics" table are not guaranteed at the absolute maximum ratings. The "Recommended Operating Conditions" table will define the conditions for actual device operation.

Recommended Operating Conditions

Symbol	Parameter		DM74ALS74A			Units
			Min	Nom	Max	
V _{CC}	Supply Voltage		4.5	5	5.5	V
V _{IH}	High Level Input Voltage		2			V
V _{IL}	Low Level Input Voltage				0.8	V
I _{OH}	High Level Output Current				-0.4	mA
I _{OL}	Low Level Output Current				8	mA
f _{CLK}	Clock Frequency		0		34	MHz
t _{w(CLK)}	Width of Clock Pulse	High	14.5			ns
		Low	14.5			ns
t _w	Pulse Width Preset & Clear	Low	14.5			ns
t _{SU}	Data Setup Time	Data	15 ↑			ns
		PRE or CLR Inactive	10 ↑			
t _H	Data Hold Time		0 ↑			ns
T _A	Free Air Operating Temperature		0		70	°C

The (↑) arrow indicates the positive edge of the Clock is used for reference.

Electrical Characteristics

over recommended operating free air temperature range. All typical values are measured at V_{CC} = 5V, T_A = 25°C.

Symbol	Parameter	Conditions	Min	Typ	Max	Units
V _{IK}	Input Clamp Voltage	V _{CC} = 4.5V, I _I = -18 mA			-1.5	V
V _{OH}	High Level Output Voltage	I _{OH} = -0.4 mA V _{CC} = 4.5V to 5.5V	V _{CC} - 2			V
V _{OL}	Low Level Output Voltage	V _{CC} = 4.5V V _{IH} = 2V 74ALS I _{OL} = 8 mA		0.35	0.5	V
I _I	Input Current @ Max Input Voltage	V _{CC} = 5.5V, V _{IH} = 7V	Clock, D		0.1	mA
			Preset, Clear		0.2	
I _{IH}	High Level Input Current	V _{CC} = 5.5V, V _{IH} = 2.7V	Clock, D		20	μA
			Preset, Clear		40	
I _{IL}	Low Level Input Current	V _{CC} = 5.5V, V _{IL} = 0.4V	Clock, D		-0.2	mA
			Preset, Clear		-0.4	
I _O	Output Drive Current	V _{CC} = 5.5V, V _O = 2.25V	-30		-112	mA
I _{CC}	Supply Current	V _{CC} = 5.5V (Note 1)		2.4	4	mA

Note 1: I_{CC} is measured with D, CLK and PRESET grounded, then with D, CLK and CLEAR grounded.

Note 2: I_{IL} PRE and CLR pins not guaranteed to meet specifications with both PRE and CLK low.

Switching Characteristics

over recommended operating free air temperature range (Note 1).

Parameter	Conditions	From	To	DM74ALS74A		Units
				Min	Max	
f_{MAX}	$V_{CC} = 4.5V$ to $5.5V$ $R_L = 500\Omega$ $C_L = 50$ pF			34		MHz
t_{PLH}		$\overline{\text{Preset}}$ or $\overline{\text{Clear}}$	Q or \overline{Q}	3	13	ns
t_{PHL}				5	15	ns
t_{PLH}		Clock	Q or \overline{Q}	5	16	ns
t_{PHL}				5	18	ns

Note 1: See Section 5 for test waveforms and output load.

Logic Diagram

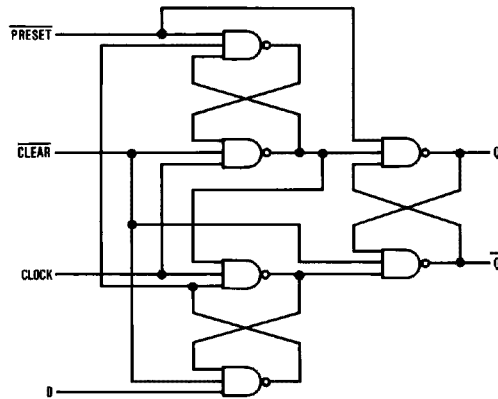

TL/F/6109-2

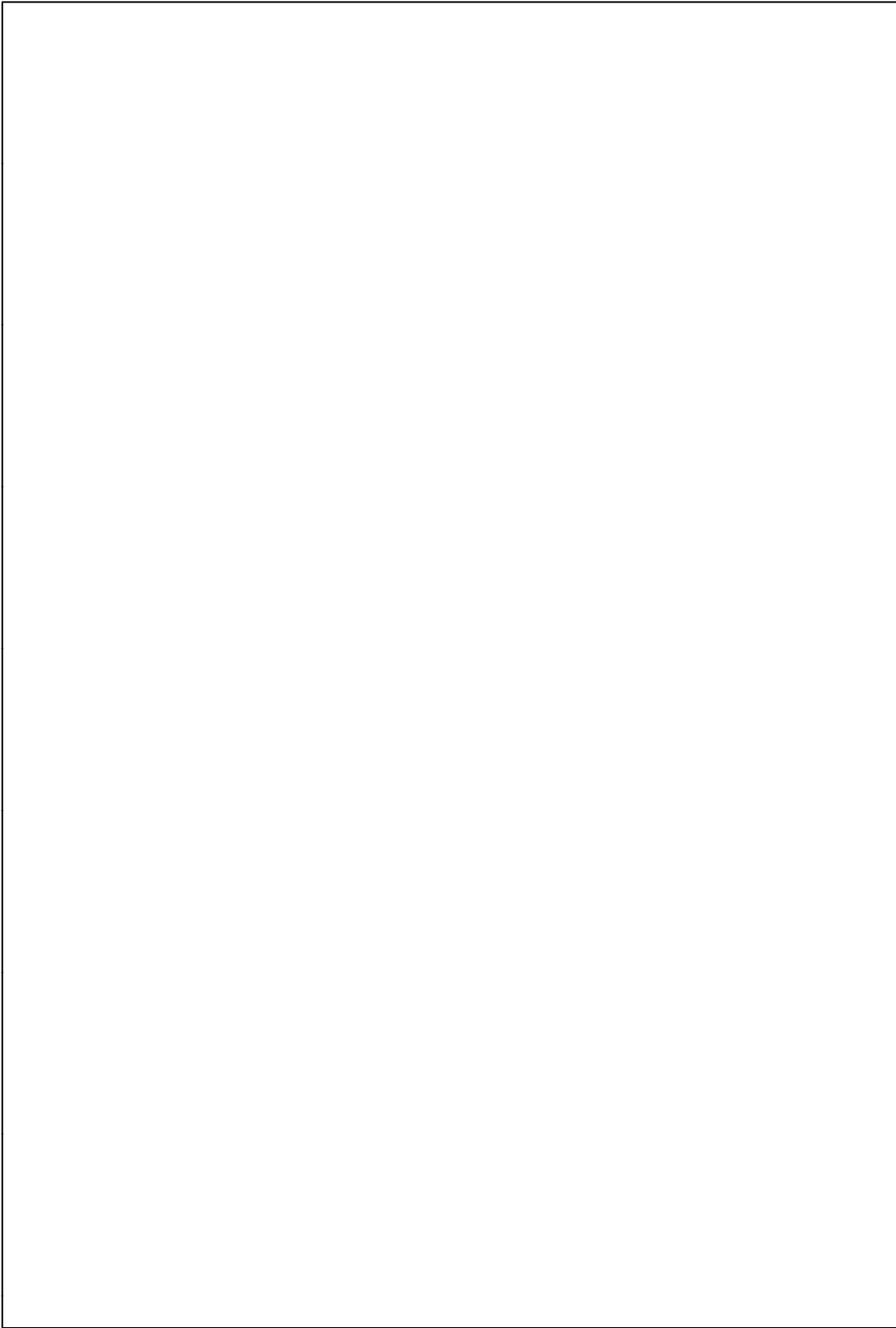

Physical Dimensions inches (millimeters) (Continued)

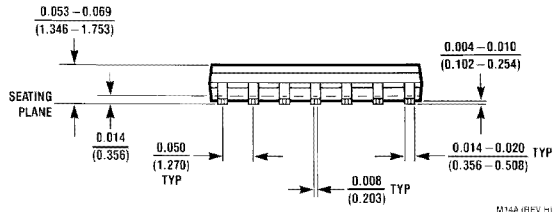
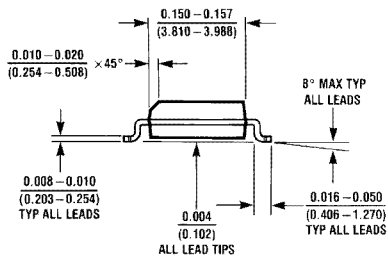
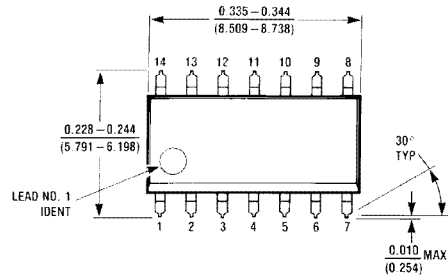

M14A (REV HI)

S.O. Package (M)
Order Number DM74ALS74AM
NS Package Number M14A

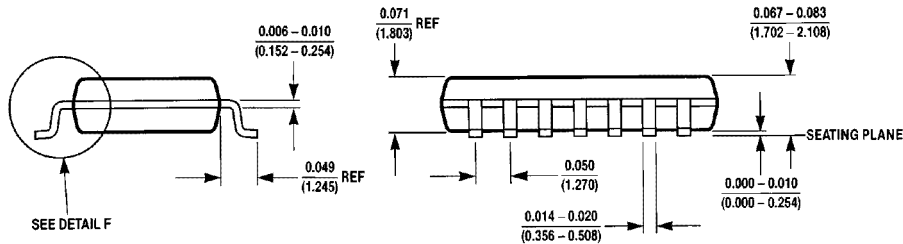
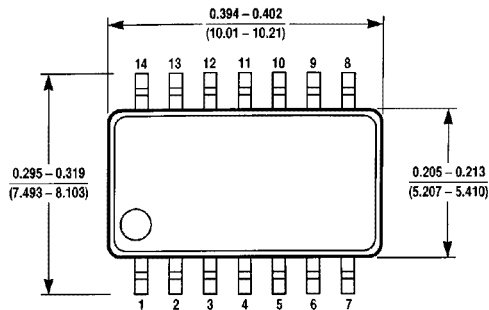
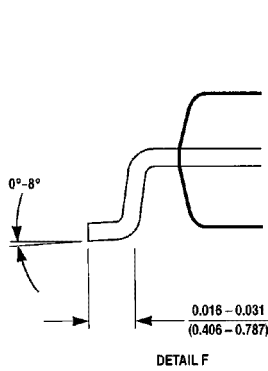

M14D (REV A)

Small Outline Package (SJ)
Order Number DM74ALS74ASJ
NS Package Number M14D

Physical Dimensions inches (millimeters) (Continued)

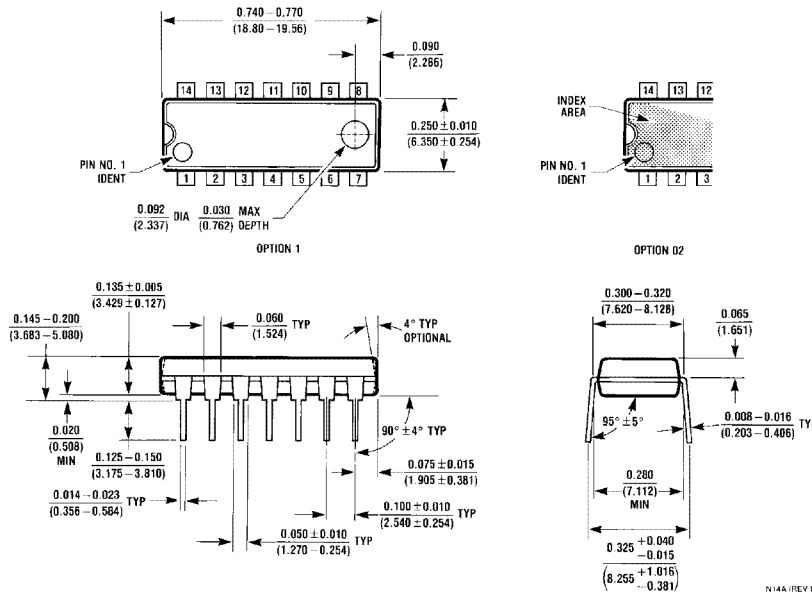

Molded Dual-In-Line Package (N)
Order Number DM74ALS74AN
NS Package Number N14A

N14A (REV F)

LIFE SUPPORT POLICY

NATIONAL'S PRODUCTS ARE NOT AUTHORIZED FOR USE AS CRITICAL COMPONENTS IN LIFE SUPPORT DEVICES OR SYSTEMS WITHOUT THE EXPRESS WRITTEN APPROVAL OF THE PRESIDENT OF NATIONAL SEMICONDUCTOR CORPORATION. As used herein:

1. Life support devices or systems are devices or systems which, (a) are intended for surgical implant into the body, or (b) support or sustain life, and whose failure to perform, when properly used in accordance with instructions for use provided in the labeling, can be reasonably expected to result in a significant injury to the user.
2. A critical component is any component of a life support device or system whose failure to perform can be reasonably expected to cause the failure of the life support device or system, or to affect its safety or effectiveness.

 <p>National Semiconductor Corporation 1111 West Bardin Road Arlington, TX 76017 Tel: 1(800) 272-9959 Fax: 1(800) 737-7018</p>	<p>National Semiconductor Europe Fax: (+49) 0-180-530 85 86 Email: cnjwge@tevm2.nsc.com Deutsch Tel: (+49) 0-180-530 85 85 English Tel: (+49) 0-180-532 78 32 Français Tel: (+49) 0-180-532 93 58 Italiano Tel: (+49) 0-180-534 16 80</p>	<p>National Semiconductor Hong Kong Ltd. 13th Floor, Straight Block, Ocean Centre, 5 Canton Rd. Tsimshatsui, Kowloon Hong Kong Tel: (852) 2737-1600 Fax: (852) 2736-9960</p>	<p>National Semiconductor Japan Ltd. Tel: 81-043-299-2309 Fax: 81-043-299-2408</p>
--	--	---	---

National does not assume any responsibility for use of any circuitry described, no circuit patent licenses are implied and National reserves the right at any time without notice to change said circuitry and specifications.