

DM74ALS257/DM74ALS258 TRI-STATE® Quad 1-of-2-Line Data Selector/Multiplexer

General Description

These data selectors/multiplexers contain inverters and drivers to supply full on-chip data selection to the four TRI-STATE outputs that can interface directly with data lines of bus-organized systems. A 4-bit word selected from one of two sources is routed to the four outputs. The ALS257 presents true data whereas the ALS258 presents inverted data to minimize propagation delay time.

This TRI-STATE output feature means that n-bit (paralleled) data selectors with up to 258 sources can be implemented for data buses. It also permits the use of standard TTL registers for data retention throughout the system.

Features

- Switching specifications at 50 pF
- Switching specifications guaranteed over full temperature and V_{CC} range
- Advanced oxide-isolated, ion-implanted Schottky TTL process
- Functionally and pin for pin compatible with Schottky and low power Schottky TTL counterpart
- Improved AC performance over Schottky and low power Schottky counterparts
- TRI-STATE buffer-type outputs drive bus lines directly
- Expand any data input point
- Multiplex dual data buses
- General four functions of two variables (one variable is common)
- Source programmable counters

Connection Diagram

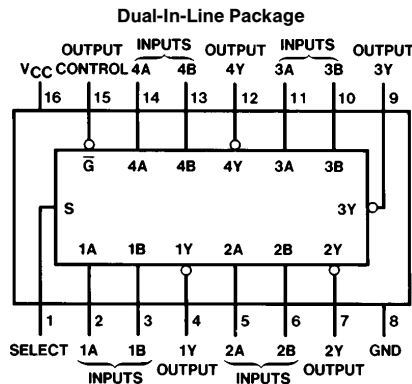

TL/F/6227-1

Order Number DM74ALS257M,
DM74ALS258M, DM74ALS257N, DM74ALS258N
See NS Package Number M16A or N16A

Function Table

Output Control	Inputs			Output Y	
	Select	A	B	ALS257	ALS258
H	X	X	X	Z	Z
L	L	L	X	L	H
L	L	H	X	H	L
L	H	X	L	L	H
L	H	X	H	H	L

H = High Level, L = Low Level, X = Don't Care
Z = High Impedance (off)

TRI-STATE® is a registered trademark of National Semiconductor Corporation.

Absolute Maximum Ratings

Supply Voltage	7V
Input Voltage	7V
Voltage Applied to Disabled Output	5.5V
Operating Free Air Temperature Range DM74ALS	0°C to +70°C
Storage Temperature Range	-65°C to +150°C
Typical θ_{JA}	
N Package	73.0°C/W
M Package	102.0°C/W

Note: The "Absolute Maximum Ratings" are those values beyond which the safety of the device cannot be guaranteed. The device should not be operated at these limits. The parametric values defined in the "Electrical Characteristics" table are not guaranteed at the absolute maximum ratings. The "Recommended Operating Conditions" table will define the conditions for actual device operation.

Recommended Operating Conditions

Symbol	Parameter	DM74ALS257, 258			Units
		Min	Nom	Max	
V _{CC}	Supply Voltage	4.5	5	5.5	V
V _{IH}	High Level Input Voltage	2			V
V _{IL}	Low Level Input Voltage			0.8	V
I _{OH}	High Level Output Current			-2.6	mA
I _{OL}	Low Level Output Current			24	mA
T _A	Free Air Operating Temperature	0		70	°C

Electrical Characteristics

over recommended operating free air temperature range. All typical values are measured at V_{CC} = 5V, T_A = 25°C.

Symbol	Parameter	Conditions	Min	Typ	Max	Units	
V _{IK}	Input Clamp Voltage	V _{CC} = 4.5V, I _I = -18 mA			-1.5	V	
V _{OH}	High Level Output Voltage	V _{CC} = 4.5V, I _{OH} = -2.6 mA	2.4	3.3		V	
		I _{OH} = -0.4 mA	V _{CC} - 2			V	
V _{OL}	Low Level Output Voltage	V _{CC} = 4.5V	I _{OL} = 12 mA	0.25	0.4	V	
			I _{OL} = 24 mA		0.35	0.5	V
I _I	Input Current at Max Input Voltage	V _{CC} = 5.5V, V _{IH} = 7V			0.1	mA	
I _{IH}	High Level Input Current	V _{CC} = 5.5V, V _{IH} = 2.7V			20	μA	
I _{IL}	Low Level Input Current	V _{CC} = 5.5V, V _{IL} = 0.4V			-0.1	mA	
I _O	Output Drive Current	V _{CC} = 5.5V, V _O = 2.25V	-30		-112	mA	
I _{OZH}	Off-State Output Current, High Level Voltage Applied	V _{CC} = 5.5V, V _O = 2.7V			20	μA	
I _{OZL}	Off-State Output Current, Low Level Voltage Applied	V _{CC} = 5.5V, V _O = 0.4V			-20	μA	
I _{CCH}	Supply Current	ALS257 ALS258	V _{CC} = 5.5V Outputs Open	Outputs High	3	6	mA
					2.5	4	mA
I _{CCL}	Supply Current	ALS257 ALS258	V _{CC} = 5.5V Outputs Open	Outputs Low	8	12	mA
					7	11	mA
I _{CCZ}	Supply Current	ALS257 ALS258	V _{CC} = 5.5V Outputs Disabled	Outputs Disabled	9	14	mA
					8	13	mA

'ALS257 Switching Characteristics over recommended operating free air temperature range (Note 1)

Symbol	Parameter	Conditions	From	To	DM74ALS257		Units
					Min	Max	
t _{PLH}	Propagation Delay Time Low to High Level Output	V _{CC} = 4.5V to 5.5V C _L = 50 pF R _L = 500Ω	Data	Any Y	2	10	ns
t _{PHL}	Propagation Delay Time High to Low Level Output		Data	Any Y	2	12	ns
t _{PLH}	Propagation Delay Time Low to High Level Output		Select	Any Y	4	18	ns
t _{PHL}	Propagation Delay Time High to Low Level Output		Select	Any Y	5	22	ns
t _{ZH}	Output Enable Time to High Level		Output Control	Any Y	4	16	ns
t _{ZL}	Output Enable Time to Low Level		Output Control	Any Y	5	18	ns
t _{HZ}	Output Disable Time from High Level		Output Control	Any Y	2	10	ns
t _{LZ}	Output Disable Time from Low Level		Output Control	Any Y	3	15	ns

'ALS258 Switching Characteristics over recommended operating free air temperature range (Note 1)

Symbol	Parameter	Conditions	From	To	DM74ALS258		Units
					Min	Max	
t _{PLH}	Propagation Delay Time Low to High Level Output	V _{CC} = 4.5V to 5.5V C _L = 50 pF R _L = 500Ω	Data	Any Y	2	8	ns
t _{PHL}	Propagation Delay Time High to Low Level Output		Data	Any Y	2	7	ns
t _{PLH}	Propagation Delay Time Low to High Level Output		Select	Any Y	3	20	ns
t _{PHL}	Propagation Delay Time High to Low Level Output		Select	Any Y	5	25	ns
t _{ZH}	Output Enable Time to High Level		Output Control	Any Y	5	18	ns
t _{ZL}	Output Enable Time to Low Level		Output Control	Any Y	5	18	ns
t _{HZ}	Output Disable Time from High Level		Output Control	Any Y	2	10	ns
t _{LZ}	Output Disable Time from Low Level		Output Control	Any Y	3	18	ns

Note 1: See Section 5 for test waveforms and output load.

Logic Diagrams

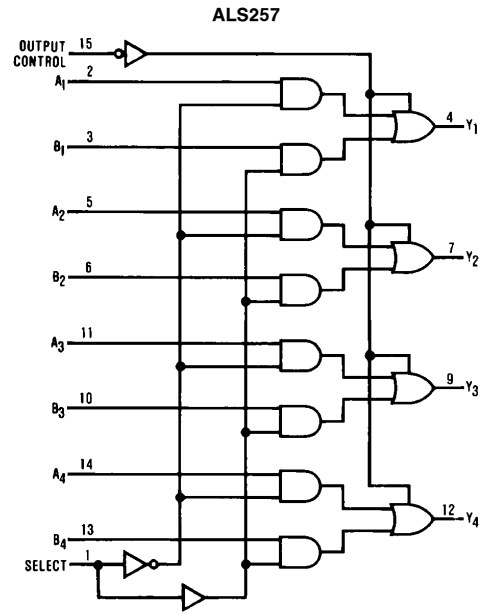

TL/F/6227-2

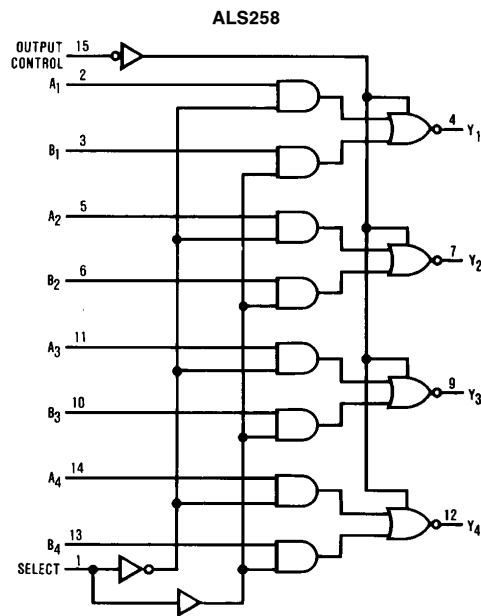

TL/F/6227-3

Physical Dimensions inches (millimeters)

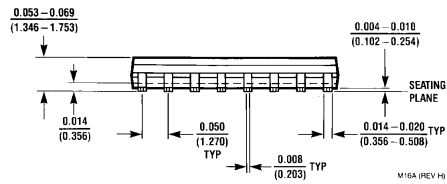
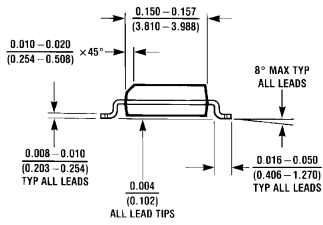
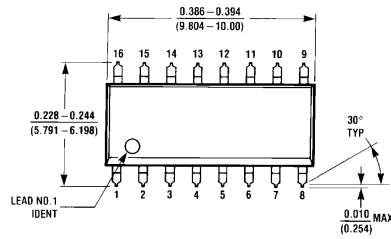

S.O. Package (M)
Order Number DM74ALS257M or DM74ALS258M
NS Package Number M16A

Physical Dimensions inches (millimeters) (Continued)

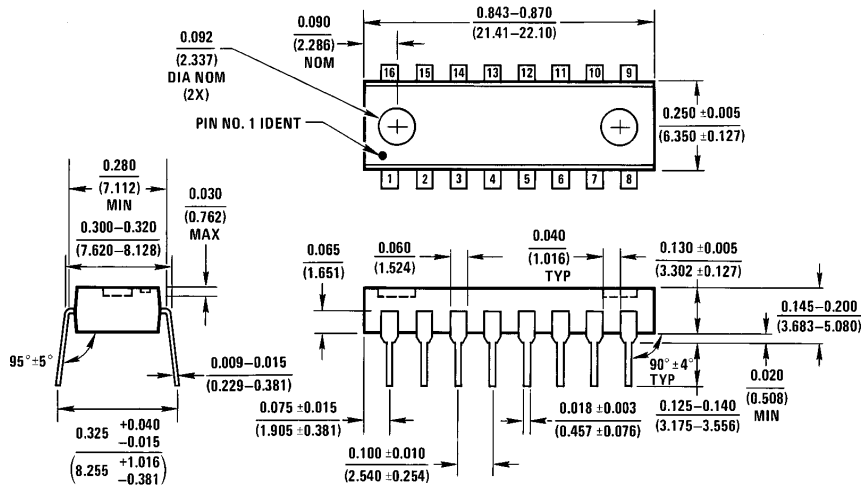

N16A (REV E)

Molded Dual-In-Line Package (N)
Order Number DM74ALS257N or DM74ALS258N
NS Package Number N16A

LIFE SUPPORT POLICY

NATIONAL'S PRODUCTS ARE NOT AUTHORIZED FOR USE AS CRITICAL COMPONENTS IN LIFE SUPPORT DEVICES OR SYSTEMS WITHOUT THE EXPRESS WRITTEN APPROVAL OF THE PRESIDENT OF NATIONAL SEMICONDUCTOR CORPORATION. As used herein:

1. Life support devices or systems are devices or systems which, (a) are intended for surgical implant into the body, or (b) support or sustain life, and whose failure to perform, when properly used in accordance with instructions for use provided in the labeling, can be reasonably expected to result in a significant injury to the user.
2. A critical component is any component of a life support device or system whose failure to perform can be reasonably expected to cause the failure of the life support device or system, or to affect its safety or effectiveness.



National Semiconductor Corporation
 2900 Semiconductor Drive
 P.O. Box 58090
 Santa Clara, CA 95052-8090
 Tel: (1800) 272-9959
 TWX: (910) 339-9240

National Semiconductor GmbH
 Livny-Gargan-Str. 10
 D-82256 Fürstenfeldbruck
 Germany
 Tel: (81-41) 35-0
 Telex: 527849
 Fax: (81-41) 35-1

National Semiconductor Japan Ltd.
 Sumitomo Chemical
 Engineering Center
 Bldg. 7F
 1-7-1, Nakase, Mihama-Ku
 Chiba-City,
 Chiba Prefecture 261
 Tel: (043) 299-2300
 Fax: (043) 299-2500

National Semiconductor Hong Kong Ltd.
 13th Floor, Straight Block,
 Ocean Centre, 5 Canton Rd.
 Tsimshatsui, Kowloon
 Hong Kong
 Tel: (852) 2737-1600
 Fax: (852) 2736-9960

National Semicondutores Do Brazil Ltda.
 Rue Deputado Lacorda Franco
 120-3A
 Sao Paulo-SP
 Brazil 05418-000
 Tel: (55-11) 212-5066
 Telex: 391-1131931 NSBR BR
 Fax: (55-11) 212-1181

National Semiconductor (Australia) Pty. Ltd.
 Building 16
 Business Park Drive
 Monash Business Park
 Nottingham, Melbourne
 Victoria 3168 Australia
 Tel: (3) 558-9999
 Fax: (3) 558-9998

National does not assume any responsibility for use of any circuitry described, no circuit patent licenses are implied and National reserves the right at any time without notice to change said circuitry and specifications.