

DM74ALS174, DM74ALS175 Hex/Quad D-Type Flip-Flops with Clear

Features

- Advanced oxide-isolated ion-implanted Schottky TTL process
- Pin and functional compatible with LS family counterpart
- Typical clock frequency maximum is 80MHz
- Switching performance guaranteed over full temperature and V_{CC} supply range

General Description

These positive-edge-triggered flip-flops utilize TTL circuitry to implement D-type flip-flop logic. Both have an asynchronous clear input, and the quad (DM74ALS175) version features complementary outputs from each flip-flop.

Information at the D inputs meeting the setup time requirements is transferred to the Q outputs on the positive-going edge of the clock pulse. Clock triggering occurs at a particular voltage level and is not directly related to the transition time of the positive-going pulse. When the clock input is at either the HIGH or LOW level, the D input signal has no effect at the output.

Ordering Information

Ordering Code	Package Number	Package Description
DM74ALS174M	M16A	16-Lead Small Outline Integrated Circuit (SOIC), JEDEC MS-012, 0.150" Narrow
DM74ALS174SJ	M16D	16-Lead Small Outline Package (SOP), EIAJ TYPE II, 5.3mm Wide
DM74ALS175M	M16A	16-Lead Small Outline Integrated Circuit (SOIC), JEDEC MS-012, 0.150" Narrow
DM74ALS175SJ	M16D	16-Lead Small Outline Package (SOP), EIAJ TYPE II, 5.3mm Wide
DM74ALS175N	N16E	16-Lead Plastic Dual-In-Line Package (PDIP), JEDEC MS-001, 0.300" Wide

Devices also available in Tape and Reel. Specify by appending the suffix letter "X" to the ordering number.

Connection Diagrams

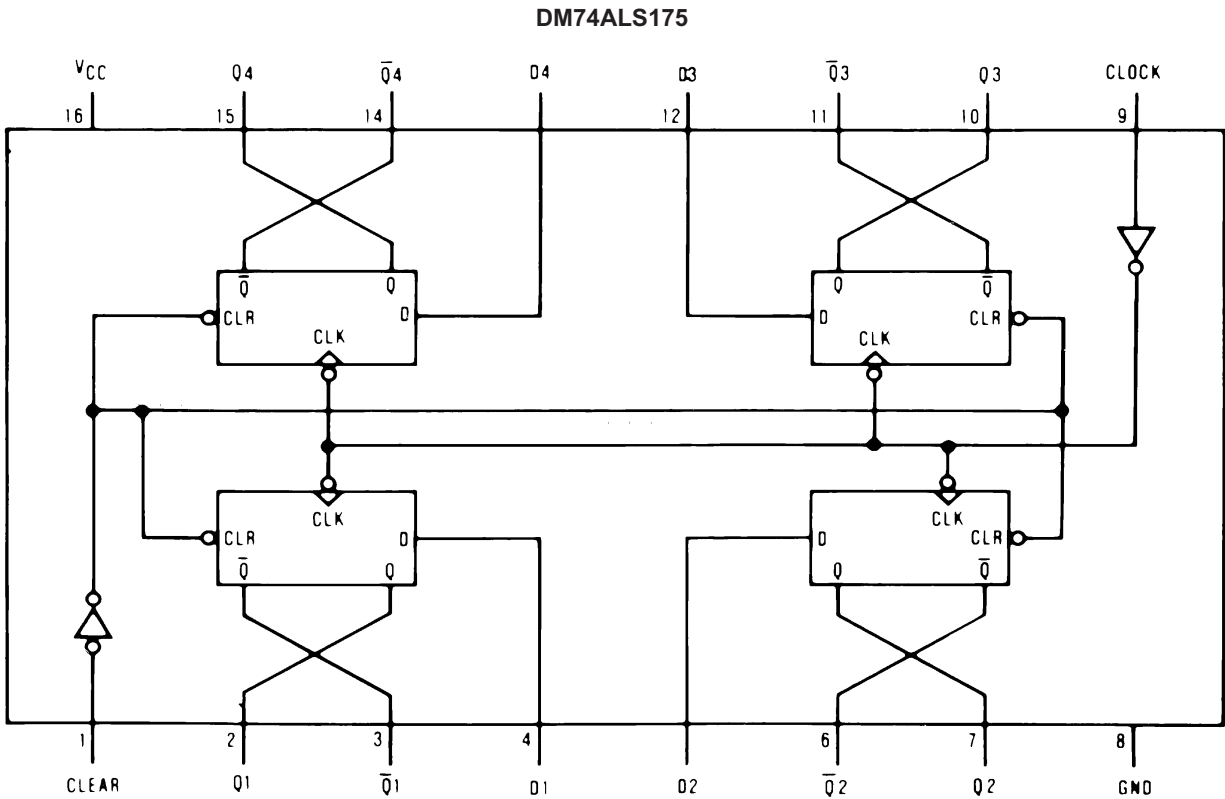
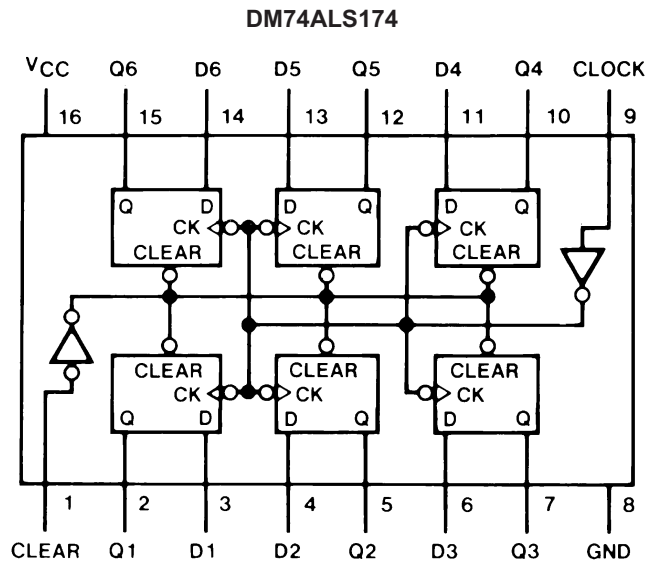

Function Table

Inputs			Outputs	
Clear	Clock	D	Q	$\overline{Q}^{(1)}$
L	X	X	L	H
H	↑	H	H	L
H	↑	L	L	H
H	L	X	Q_0	\overline{Q}_0

H = HIGH Level (steady state) L = LOW Level (steady state)
 X = Don't Care ↑ = Transition from LOW-to-HIGH Level
 Q_0 = the level of Q before the indicated steady-state input conditions were established.

Note:

1. Applies to DM74ALS175 only.

Logic Diagrams

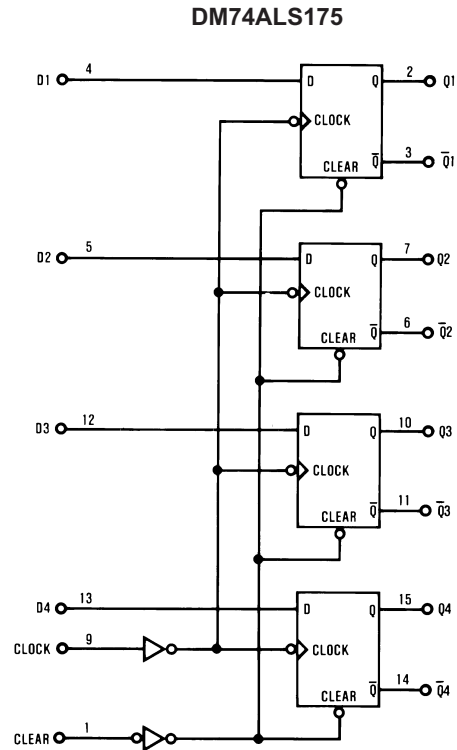
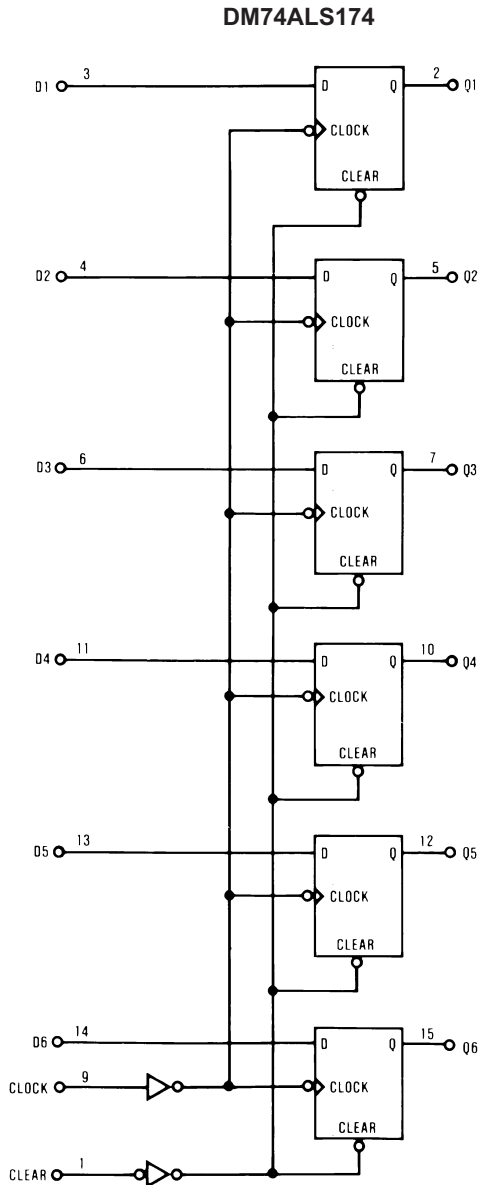

Absolute Maximum Ratings

Stresses exceeding the absolute maximum ratings may damage the device. The device may not function or be operable above the recommended operating conditions and stressing the parts to these levels is not recommended. In addition, extended exposure to stresses above the recommended operating conditions may affect device reliability. The absolute maximum ratings are stress ratings only.

Symbol	Parameter	Rating
V_{CC}	Supply Voltage	7V
V_I	Input Voltage	7V
T_A	Operating Free Air Temperature Range	0°C to +70°C
T_{STG}	Storage Temperature Range	-65°C to +150°C
θ_{JA}	Typical Thermal Resistance	
	N Package	77.9°C/W
	M Package	107.3°C/W

Recommended Operating Conditions

The Recommended Operating Conditions table defines the conditions for actual device operation. Recommended operating conditions are specified to ensure optimal performance to the datasheet specifications. Fairchild does not recommend exceeding them or designing to absolute maximum ratings.

Symbol	Parameter		Min.	Nom.	Max.	Units
V_{CC}	Supply Voltage		4.5	5	5.5	V
V_{IH}	HIGH Level Input Voltage		2			V
V_{IL}	LOW Level Input Voltage				0.8	V
I_{OH}	HIGH Level Output Current				-0.4	mA
I_{OL}	LOW Level Output Current				8	mA
t_W	Pulse Width	Clock HIGH or LOW	10			ns
		Clear LOW	10			
t_{SETUP}	Setup Time ⁽²⁾	Data Input	10 \uparrow			ns
		Clear, Inactive State	6 \uparrow			
t_{HOLD}	Data Hold Time ⁽²⁾		0 \uparrow			ns
f_{CLOCK}	Clock Frequency		0		50	MHz
T_A	Free Air Operating Temperature		0		70	°C

Note:

2. The symbol \uparrow indicates that the rising edge of the clock is used as reference.

Electrical Characteristics

Over recommended operating free air temperature range. All typical values are measured at $V_{CC} = 5V$, $T_A = 25^\circ C$.

Symbol	Parameter	Conditions	Min.	Typ.	Max.	Units	
V_{IK}	Input Clamp Voltage	$V_{CC} = 4.5V$, $I_{IN} = -18\text{ mA}$			-1.5	V	
V_{OH}	HIGH Level Output Voltage	$I_{OH} = -400\mu A$, $V_{CC} = 4.5V$ to $5.5V$	$V_{CC} - 2$	$V_{CC} - 1.6$		V	
V_{OL}	LOW Level Output Voltage	$V_{CC} = 4.5V$, $I_{OL} = 8\text{ mA}$		0.35	0.5	V	
I_I	Input Current at Max. Input Voltage	$V_{CC} = 5.5V$, $V_{IN} = 7V$			0.1	mA	
I_{IH}	HIGH Level Input Current	$V_{CC} = 5.5V$, $V_{IH} = 2.7V$			20	μA	
I_{IL}	LOW Level Input Current	$V_{CC} = 5.5V$, $V_{IN} = 0.4V$			-0.1	mA	
I_O	Output Drive Current	$V_{CC} = 5.5V$, $V_O = 2.25V$	-30		-112	mA	
I_{CC}	Supply Current	$V_{CC} = 5.5V$, Clock = $4.5V$, Clear = GND, D Input = GND	DM74ALS174		11	19	mA
			DM74ALS175		8	14	

Switching Characteristics

Over recommended operating free air temperature range.

Symbol	Parameter	Conditions	Min.	Max.	Units
f_{MAX}	Maximum Clock Frequency	$R_L = 500\Omega$, $C_L = 50\text{ pF}$, $V_{CC} = 4.5V$ to $5.5V$	50		MHz
t_{PLH}	Propagation Delay Time, LOW-to-HIGH Level Output From Clear (175 Only)		5	18	ns
t_{PHL}	Propagation Delay Time, HIGH-to-LOW Level Output From Clear		8	23	ns
t_{PLH}	Propagation Delay Time, LOW-to-HIGH Level Output From Clock		3	15	ns
t_{PHL}	Propagation Delay Time, HIGH-to-LOW Level Output From Clock		5	17	ns

Physical Dimensions

Dimensions are in millimeters unless otherwise noted.

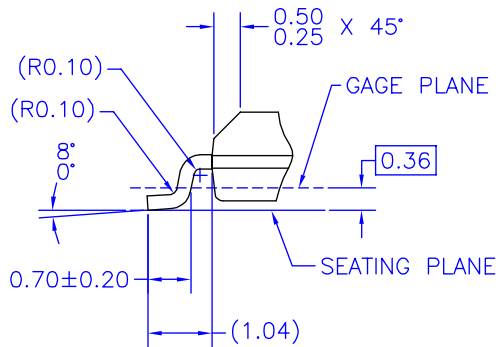
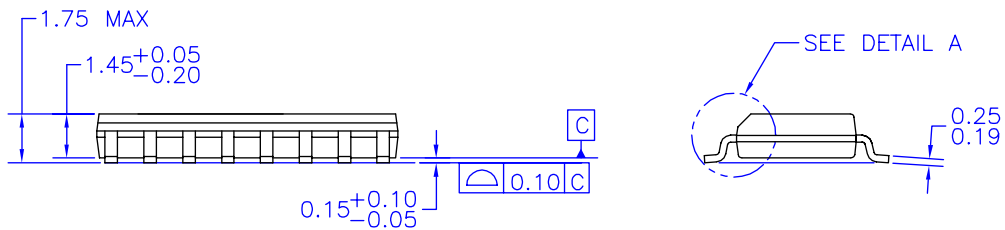
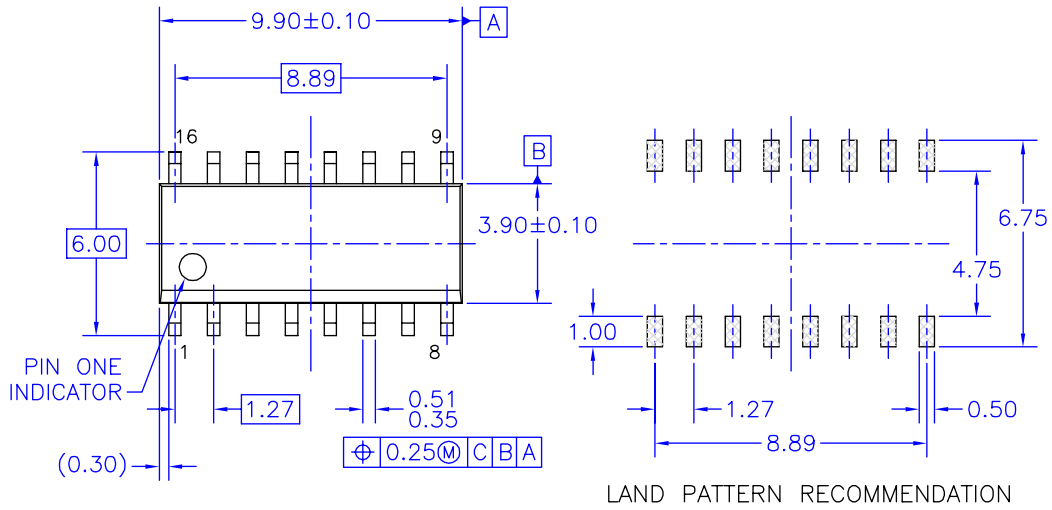

NOTES: UNLESS OTHERWISE SPECIFIED

- A) THIS PACKAGE CONFORMS TO JEDEC MS-012, VARIATION AC, ISSUE C, DATED MAY 1990.
- B) ALL DIMENSIONS ARE IN MILLIMETERS.
- C) DIMENSIONS DO NOT INCLUDE MOLD FLASH OR BURRS.
- D) STANDARD LEAD FINISH:
200 MICRONS / 5.08 MICRONS MIN.
LEAD/TIN (SOLDER) ON COPPER.

M16AREVK

Figure 1. 16-Lead Small Outline Integrated Circuit (SOIC), JEDEC MS-012, 0.150" Narrow Package Number M16A

Physical Dimensions (Continued)

Dimensions are in millimeters unless otherwise noted.

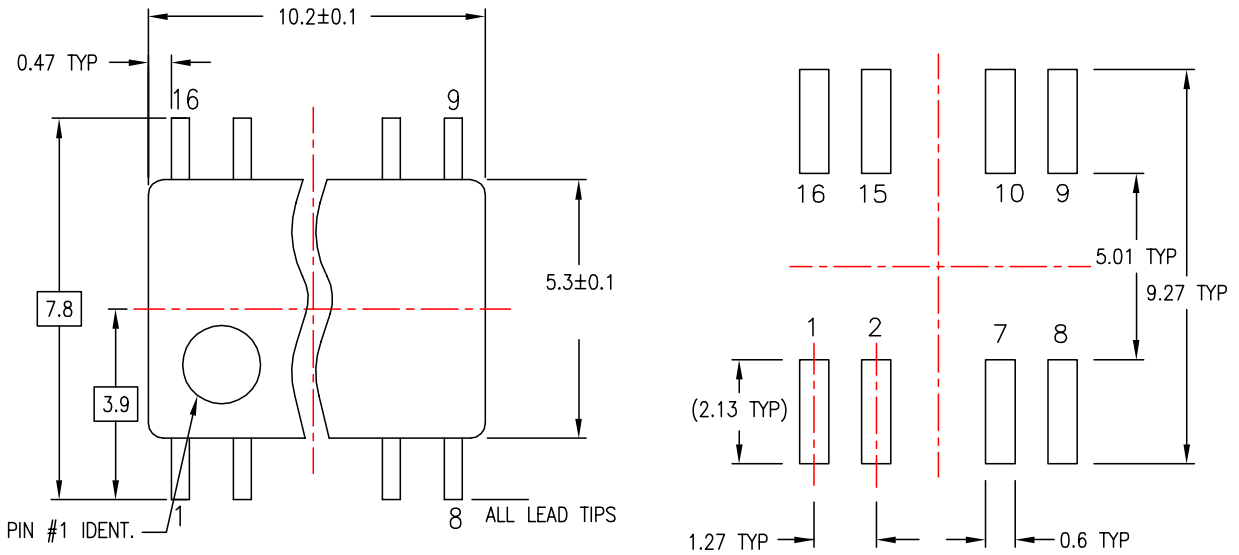

LAND PATTERN RECOMMENDATION

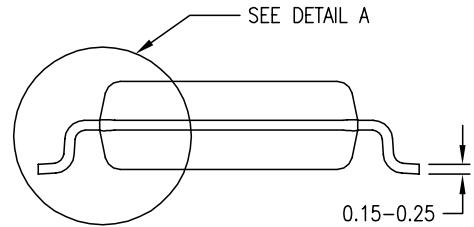
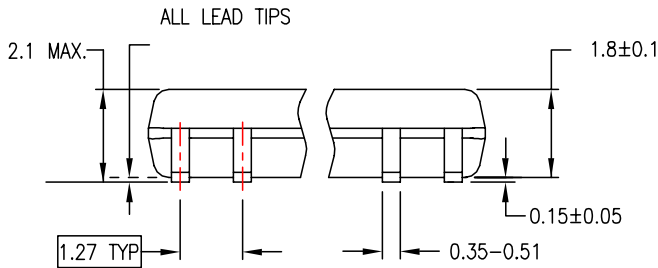

DIMENSIONS ARE IN MILLIMETERS

NOTES:

- A. CONFORMS TO EIAJ EDR-7320 REGISTRATION, ESTABLISHED IN DECEMBER, 1998.
- B. DIMENSIONS ARE IN MILLIMETERS.
- C. DIMENSIONS ARE EXCLUSIVE OF BURRS, MOLD FLASH, AND TIE BAR EXTRUSIONS.

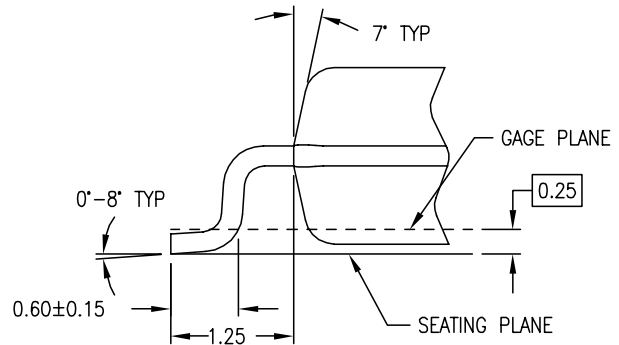

DETAIL A

M16DREVC

Figure 2. 16-Lead Small Outline Package (SOP), EIAJ TYPE II, 5.3mm Wide Package Number M16D

Physical Dimensions (Continued)

Dimensions are in inches (millimeters) unless otherwise noted.

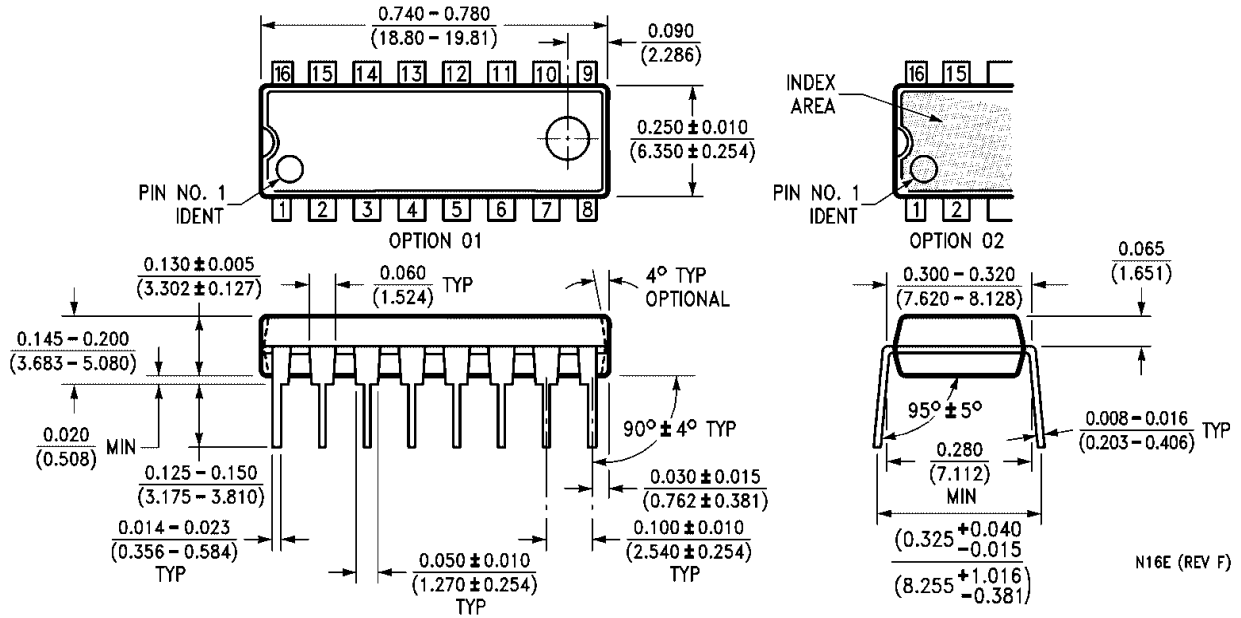



Figure 3. 16-Lead Plastic Dual-In-Line Package (PDIP), JEDEC MS-001, 0.300" Wide Package Number N16E

N16E (REV F)



TRADEMARKS

The following are registered and unregistered trademarks and service marks Fairchild Semiconductor owns or is authorized to use and is not intended to be an exhaustive list of all such trademarks

ACEx®	Green FPS™ e-Series™	Power-SPM™	SyncFET™
Build it Now™	GTO™	PowerTrench®	The Power Franchise®
CorePLUS™	<i>i-Lo</i> ™	Programmable Active Droop™	 ™
CROSSVOLT™	IntelliMAX™	QFET®	TinyBoost™
CTL™	ISOPLANAR™	QS™	TinyBuck™
Current Transfer Logic™	MegaBuck™	QT Optoelectronics™	TinyLogic®
EcoSPARK®	MICROCOUPLER™	Quiet Series™	TINYOPTO™
FACT Quiet Series™	MicroPak™	RapidConfigure™	TinyPower™
FACT®	Motion-SPM™	SMART START™	TinyPWM™
FAST®	OPTOLOGIC®	SPM®	TinyWire™
FastvCore™	OPTOPLANAR®	STEALTH™	μSerDes™
FPS™	PDP-SPM™	SuperFET™	UHC®
FRFET®	Power220®	SuperSOT™-3	UniFET™
Global Power Resource™	Power247®	SuperSOT™-6	VCX™
Green FPS™	POWEREDGE®	SuperSOT™-8	

DISCLAIMER

FAIRCHILD SEMICONDUCTOR RESERVES THE RIGHT TO MAKE CHANGES WITHOUT FURTHER NOTICE TO ANY PRODUCTS HEREIN TO IMPROVE RELIABILITY, FUNCTION, OR DESIGN. FAIRCHILD DOES NOT ASSUME ANY LIABILITY ARISING OUT OF THE APPLICATION OR USE OF ANY PRODUCT OR CIRCUIT DESCRIBED HEREIN; NEITHER DOES IT CONVEY ANY LICENSE UNDER ITS PATENT RIGHTS, NOR THE RIGHTS OF OTHERS. THESE SPECIFICATIONS DO NOT EXPAND THE TERMS OF FAIRCHILD'S WORLDWIDE TERMS AND CONDITIONS, SPECIFICALLY THE WARRANTY THEREIN, WHICH COVERS THESE PRODUCTS.

LIFE SUPPORT POLICY

FAIRCHILD'S PRODUCTS ARE NOT AUTHORIZED FOR USE AS CRITICAL COMPONENTS IN LIFE SUPPORT DEVICES OR SYSTEMS WITHOUT THE EXPRESS WRITTEN APPROVAL OF FAIRCHILD SEMICONDUCTOR CORPORATION.

As used herein:

- Life support devices or systems are devices or systems which, (a) are intended for surgical implant into the body, or (b) support or sustain life, and (c) whose failure to perform when properly used in accordance with instructions for use provided in the labeling, can be reasonably expected to result in significant injury to the user.
- A critical component is any component of a life support device or system whose failure to perform can be reasonably expected to cause the failure of the life support device or system, or to affect its safety or effectiveness.

PRODUCT STATUS DEFINITIONS

Definition of Terms

Datasheet Identification	Product Status	Definition
Advance Information	Formative or In Design	This datasheet contains the design specifications for product development. Specifications may change in any manner without notice.
Preliminary	First Production	This datasheet contains preliminary data; supplementary data will be published at a later date. Fairchild Semiconductor reserves the right to make changes at any time without notice to improve design.
No Identification Needed	Full Production	This datasheet contains final specifications. Fairchild Semiconductor reserves the right to make changes at any time without notice to improve design.
Obsolete	Not In Production	This datasheet contains specifications on a product that has been discontinued by Fairchild semiconductor. The datasheet is printed for reference information only.

Rev. I28