



DM54S240/DM74S240, DM54S241/DM74S241, DM54S244/DM74S244 Octal TRI-STATE® Buffers/Line Drivers/Line Receivers

General Description

These buffers/line drivers are designed to improve both the performance and PC board density of TRI-STATE buffers/drivers employed as memory-address drivers, clock drivers, and bus-oriented transmitters/receivers. Featuring 400 mV of hysteresis at each low current PNP data line input, they provide improved noise rejection and high fanout outputs, and can be used to drive terminated lines down to 133Ω.

Features

- TRI-STATE outputs drive bus lines directly
- PNP inputs reduce DC loading on bus lines
- Hysteresis at data inputs improves noise margins
- Typical I_{OL} (sink current)
 - 54S 48 mA
 - 74S 64 mA
- Typical I_{OH} (source current)
 - 54S -12 mA
 - 74S -15 mA
- Typical propagation delay times
 - Inverting 4.5 ns
 - Noninverting 6 ns
- Typical enable/disable times 9 ns
- Typical power dissipation (enabled)
 - Inverting 450 mW
 - Noninverting 538 mW

Connection Diagrams

Dual-In-Line Package

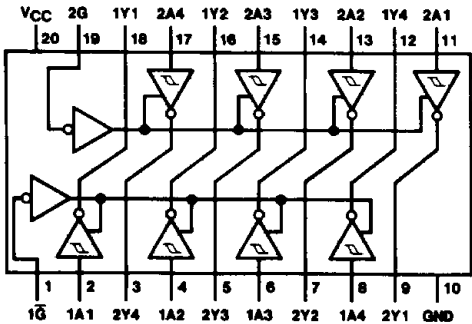

TL/F/6478-1

Order Number DM54S240J,
DM74S240WM or DM74S240N
See NS Package Number
J20A, M20B or N20A

Dual-In-Line Package

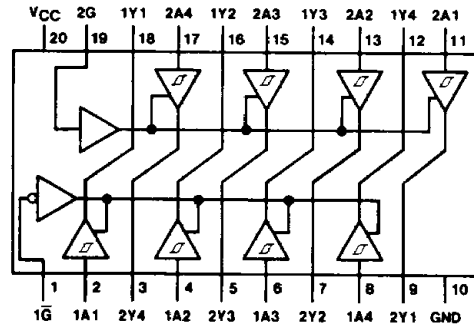

TL/F/6478-2

Order Number DM54S241J
or DM74S241N
See NS Package Number
J20A or N20A

Dual-In-Line Package

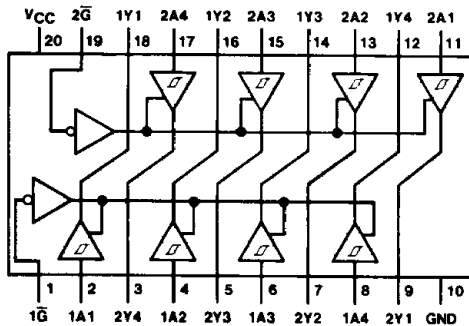

TL/F/6478-3

Order Number DM54S244J,
DM74S244WM or DM74S244N
See NS Package Number
J20A, M20B or N20A

Absolute Maximum Ratings (Note)

If Military/Aerospace specified devices are required, please contact the National Semiconductor Sales Office/Distributors for availability and specifications.

Supply Voltage	7V
Input Voltage	5.5V
Operating Free Air Temperature Range	
DM54S	-55°C to +125°C
DM74S	0°C to +70°C
Storage Temperature Range	-65°C to +150°C

Note: The "Absolute Maximum Ratings" are those values beyond which the safety of the device cannot be guaranteed. The device should not be operated at these limits. The parametric values defined in the "Electrical Characteristics" table are not guaranteed at the absolute maximum ratings. The "Recommended Operating Conditions" table will define the conditions for actual device operation.

Recommended Operating Conditions

Symbol	Parameter	DM54S			DM74S			Units
		Min	Typ	Max	Min	Typ	Max	
V _{CC}	Supply Voltage	4.5	5	5.5	4.75	5	5.5	V
V _{IH}	High Level Input Voltage	2			2			V
V _{IL}	Low Level Input Voltage			0.8			0.8	V
I _{OH}	High Level Output Current			-12			-15	mA
I _{OL}	Low Level Output Current			48			64	mA
T _A	Free Air Operating Temperature	-55		125	0		70	°C

Electrical Characteristics over recommended operating free-air temperature range (unless otherwise noted)

Symbol	Parameter	Conditions	Min	Typ (Note 1)	Max	Units
V _I	Input Clamp Voltage	V _{CC} = Min, I _I = -18 mA			-1.2	V
H _{ys}	Hysteresis (V _{T+} - V _{T-}) (Data Inputs Only)	V _{CC} = Min	0.2	0.4		V
V _{OH}	High Level Output Voltage	V _{CC} = 4.75V, V _{IH} = 2V V _{IL} = 0.8V, I _{OH} = -1 mA	DM74	2.7		V
		V _{CC} = Min, V _{IH} = 2V V _{IL} = 0.8V, I _{OH} = -3 mA		2.4	3.4	
		V _{CC} = Min, V _{IH} = 2V V _{IL} = 0.5V, I _{OH} = Max		2		
V _{OL}	Low Level Output Voltage	V _{CC} = Min, I _{OL} = Max V _{IL} = 0.8V, V _{IH} = 2V	DM54		0.55	V
			DM74		0.55	
I _{OZH}	Off-State Output Current, High Level Voltage Applied	V _{CC} = Max V _{IL} = 0.8V V _{IH} = 2V			50	μA
I _{OZL}	Off-State Output Current, Low Level Voltage Applied				-50	μA
I _I	Input Current at Maximum Input Voltage	V _{CC} = Max, V _I = 5.5V			1	mA
I _{IH}	High Level Input Current	V _{CC} = Max, V _I = 2.7V			50	μA
I _{IL}	Low Level Input Current	V _{CC} = Max, V _I = 0.5V	Any A		-400	μA
			Any G		-2	mA

Electrical Characteristics

over recommended operating free-air temperature range (unless otherwise noted) (Continued)

Symbol	Parameter	Conditions	Min	Typ (Note 1)	Max	Units
I_{OS}	Short Circuit Output Current	$V_{CC} = \text{Max}$ (Note 2)	-50		-225	mA
I_{CC}	Supply Current	Outputs High	DM54S240	80	123	mA
			DM74S240	80	135	
			DM54S241, 244	95	147	
			DM74S241, 244	95	160	
		Outputs Low	DM54S240	100	145	
			DM74S240	100	150	
			DM54S241, 244	120	170	
			DM74S241, 244	120	180	
		Outputs Disabled	DM54S240	100	145	
			DM74S240	100	150	
			DM54S241, 244	120	170	
			DM74S241, 244	120	180	

Note 1: All typical values are at $V_{CC} = 5V$, $T_A = 25^\circ\text{C}$.

Note 2: Not more than one output should be shorted at a time and duration should not exceed one second.

Switching Characteristics $V_{CC} = 5V$, $T_A = 25^\circ\text{C}$ (See Section 1 for Test Waveforms and Output Load)

Symbol	Parameter	Conditions	Min	Max	Units	
t_{PLH}	Propagation Delay Time Low to High Level Output	$C_L = 45\text{ pF}$ $R_L = 90\Omega$	DM54/74S240	2	7	ns
			DM54/74S241, 244	2	9	
t_{PHL}	Propagation Delay Time High to Low Level Output	$C_L = 45\text{ pF}$ $R_L = 90\Omega$	DM54/74S240	2	7	ns
			DM54/74S241, 244	2	9	
t_{PZL}	Output Enable Time to Low Level	$C_L = 45\text{ pF}$ $R_L = 90\Omega$	DM54/74S240	3	15	ns
			DM54/74S241, 244	3	15	
t_{PZH}	Output Enable Time to High Level	$C_L = 45\text{ pF}$ $R_L = 90\Omega$	DM54/74S240	2	10	ns
			DM54/74S241, 244	3	12	
t_{PLZ}	Output Disable Time from Low Level	$C_L = 5\text{ pF}$ $R_L = 90\Omega$	DM54/74S240	4	15	ns
			DM54/74S241, 244	2	15	
t_{PHZ}	Output Disable Time from High Level	$C_L = 5\text{ pF}$ $R_L = 90\Omega$	DM54/74S240	2	9	ns
			DM54/74S241, 244	2	9	
t_{PLH}	Propagation Delay Time Low to High Level Output	$C_L = 150\text{ pF}$ $R_L = 90\Omega$	DM54/74S240	3	10	ns
			DM54/74S241, 244	4	12	
t_{PHL}	Propagation Delay Time High to Low Level Output	$C_L = 150\text{ pF}$ $R_L = 90\Omega$	DM54/74S240	3	10	ns
			DM54/74S241, 244	4	12	
t_{PZL}	Output Enable Time to Low Level	$C_L = 150\text{ pF}$ $R_L = 90\Omega$	DM54/74S240	6	21	ns
			DM54/74S241, 244	6	21	
t_{PZH}	Output Enable Time to High Level	$C_L = 150\text{ pF}$ $R_L = 90\Omega$	DM54/74S240	4	12	ns
			DM54/74S241, 244	4	15	