

## Low On-Resistance Wideband/Video Switches

### Features

- Wide Bandwidth: 500 MHz
- Low Crosstalk at 5 MHz: -85 dB
- Low  $r_{DS(on)}$ : 5  $\Omega$ , DG642
- TTL Logic Compatible
- Fast Switching:  $t_{ON}$  50 ns
- Single Supply Compatibility
- High Current: 100 mA, DG642

### Benefits

- High Precision
- Improved Frequency Response
- Low Insertion Loss
- Improved System Performance
- Reduced Board Space
- Low Power Consumption

### Applications

- RF and Video Switching
- RGB Switching
- Video Routing
- Cellular Communications
- ATE
- Radar/FLIR Systems
- Satellite Receivers
- Programmable Filters

### Description

The DG641/642/643 are high performance monolithic video switches designed for switching wide bandwidth analog and digital signals. DG641 is a quad SPST, DG642 is a single SPDT, and DG643 is a dual SPDT function. These devices have exceptionally low on-resistances (5  $\Omega$  typ—DG642), low capacitance and high current handling capability.

To achieve TTL compatibility, low channel capacitances and fast switching times, the DG641/642/643 are built on the Siliconix proprietary D/CMOS process. Each switch conducts equally well in both directions when on, and blocks up to 14  $V_{p-p}$  when off. An epitaxial layer prevents latchup.

### Functional Block Diagram and Pin Configuration

#### DG641

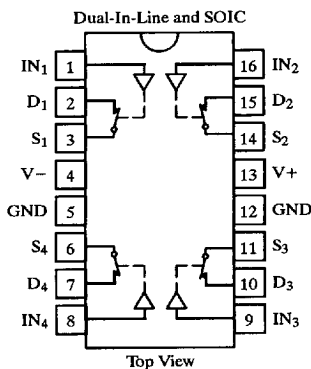

Truth Table

Logic	Switch
0	OFF
1	ON

Logic "0"  $\leq$  0.8 V  
Logic "1"  $\geq$  2.4 V

Switches Shown for Logic "1" Input

#### Ordering Information - DG641

Temp Range	Package	Part Number
-40 to 85°C	16-Pin Plastic DIP	DG641DJ
	16-Pin Narrow SOIC	DG641DY

**Functional Block Diagram and Pin Configuration**

**DG642**

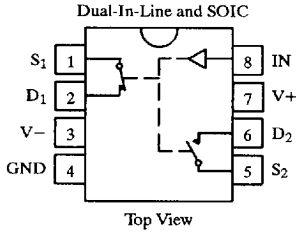

**Truth Table**

Logic	SW <sub>1</sub>	SW <sub>2</sub>
0	OFF	ON
1	ON	OFF

Logic "0" ≤ 0.8 V  
Logic "1" ≥ 2.4 V  
Switches Shown for Logic "1" Input

**Ordering Information – DG642**

Temp Range	Package	Part Number
-40 to 85°C	8-Pin Plastic DIP	DG642DJ
	8-Pin Narrow SOIC	DG642DY

**DG643**

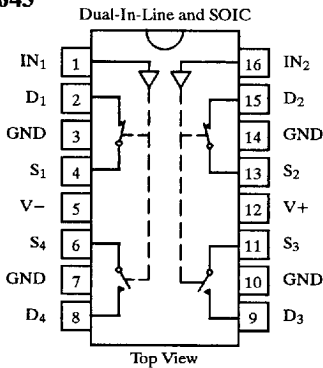

**Truth Table**

Logic	SW <sub>1</sub> , SW <sub>2</sub>	SW <sub>3</sub> , SW <sub>4</sub>
0	OFF	ON
1	ON	OFF

Logic "0" ≤ 0.8 V  
Logic "1" ≥ 2.4 V  
Switches Shown for Logic "1" Input

**Ordering Information – DG643**

Temp Range	Package	Part Number
-40 to 85°C	16-Pin Plastic DIP	DG643DJ
	16-Pin Narrow SOIC	DG643DY

**Absolute Maximum Ratings**

V+ to V-	-0.3 V to 21 V
V+ to GND	-0.3 V to 21 V
V- to GND	-19 V to +0.3 V
Digital Inputs	(V-) -0.3 V to (V+) +0.3 V or 20 mA, whichever occurs first
V <sub>S</sub> , V <sub>D</sub>	(V-) -0.3 V to (V-) +14 V or 20 mA, whichever occurs first
Continuous Current (Any Terminal Except S or D)	20 mA
Continuous Current S or D: DG641/643	75 mA
DG642	100 mA
Current, S or D (Pulsed 1 ms, 10% duty cycle max)	
DG641/643	200 mA
DG642	300 mA

Storage Temperature	-65 to 125°C
Power Dissipation (Package) <sup>b</sup>	
8-Pin Plastic DIP and Narrow SOIC <sup>c</sup>	300 mW
16-Pin Plastic DIP <sup>d</sup>	470 mW
16-Pin Narrow SOIC <sup>e</sup>	600 mW

**Notes:**

- Signals on S<sub>X</sub>, D<sub>X</sub>, or IN<sub>X</sub> exceeding V+ or V- will be clamped by internal diodes. Limit forward diode current to maximum current ratings.
- All leads welded or soldered to PC Board.
- Derate 7.6 mW/°C above 75°C
- Derate 6 mW/°C above 75°C
- Derate 10 mW/°C above 75°C

## Specifications for DG641 and DG643

Parameter	Symbol	Test Conditions Unless Otherwise Specified $V_+ = 15\text{ V}, V_- = -3\text{ V}$ $V_{\text{INH}} = 2.4\text{ V}, V_{\text{INL}} = 0.8\text{ V}^e$	Temp <sup>a</sup>	Limits -40 to 85°C			Unit
				Min <sup>c</sup>	Typ <sup>b</sup>	Max <sup>c</sup>	
<b>Analog Switch</b>							
Analog Signal Ranged <sup>d</sup>	V <sub>ANALOG</sub>	$V_- = -5\text{ V}, V_+ = 12\text{ V}$	Full	-5		8	V
		$V_- = \text{GND}, V_+ = 12\text{ V}$	Full	0		8	
Drain-Source On-Resistance	r <sub>DS(on)</sub>	$I_S = -10\text{ mA}, V_D = 0\text{ V}$	Room		8	15	Ω
r <sub>DS(on)</sub> Match	Δr <sub>DS(on)</sub>		Full			20	
Source Off Leakage Current	I <sub>S(off)</sub>	$V_S = 0\text{ V}, V_D = 10\text{ V}$	Room	-10	-0.02	10	nA
Drain Off Leakage Current	I <sub>D(off)</sub>	$V_S = 10\text{ V}, V_D = 0\text{ V}$	Full	-100	-0.02	100	
Channel On Leakage Current	I <sub>D(on)</sub>	$V_S = V_D = 0\text{ V}$	Room	-10	-0.1	10	
			Full	-100		100	
<b>Digital Control</b>							
Input Voltage High	V <sub>INH</sub>		Full	2.4			V
Input Voltage Low	V <sub>INL</sub>		Full			0.8	
Input Current	I <sub>IN</sub>	$V_{\text{IN}} = \text{GND or } V_+$	Room	-1	0.05	1	μA
			Full	-20		20	
<b>Dynamic Characteristics</b>							
On State Input Capacitance <sup>d</sup>	C <sub>S(on)</sub>	$V_S = V_D = 0\text{ V}$	Room		10	20	pF
Off State Input Capacitance <sup>d</sup>	C <sub>S(off)</sub>	$V_S = 0\text{ V}$	Room		4	12	
Off State Output Capacitance <sup>d</sup>	C <sub>D(off)</sub>	$V_D = 0\text{ V}$	Room		4	12	MHz
Bandwidth	BW	$R_L = 50\text{ Ω}, \text{ See Figure 6}$	Room		500		
Turn On Time	t <sub>ON</sub>	$R_L = 1\text{ kΩ}, C_L = 35\text{ pF}, \text{ See Figure 2}$	Room		50	70	ns
Turn Off Time	t <sub>OFF</sub>		Full			140	
Charge Injection	Q	$C_L = 1000\text{ pF}, V_D = 0\text{ V}, \text{ See Figure 3}$	Room		-19		pC
Off Isolation	OIRR	$R_{\text{IN}} = 75\text{ Ω}, R_L = 75\text{ Ω}, f = 5\text{ MHz}$ See Figure 4	Room		-60		dB
All Hostile Crosstalk	X <sub>TALK(AH)</sub>	$R_{\text{IN}} = 10\text{ Ω}, R_L = 75\text{ Ω}, f = 5\text{ MHz}$ See Figure 5	Room		-87		
<b>Power Supplies</b>							
Positive Supply Current	I <sub>+</sub>	$V_{\text{IN}} = 0\text{ V or } V_{\text{IN}} = 5\text{ V}$	Room		3.5	6	mA
Negative Supply Current	I <sub>-</sub>		Full			9	
			Room	-6	-3		
			Full	-9			

**Notes:**

- Room = 25°C, Full = as determined by the operating temperature suffix.
- Typical values are for DESIGN AID ONLY, not guaranteed nor subject to production testing.
- The algebraic convention whereby the most negative value is a minimum and the most positive a maximum, is used in this data sheet.
- Guaranteed by design, not subject to production test.
- V<sub>IN</sub> = input voltage to perform proper function.

**Specifications for DG642**

Parameter	Symbol	Test Conditions Unless Otherwise Specified  V+ = 15 V, V- = -3 V VINH = 2.4 V, VINL = 0.8 V <sup>e</sup>	Temp <sup>a</sup>	Limits -40 to 85°C			Unit
				Min <sup>c</sup>	Typ <sup>b</sup>	Max <sup>c</sup>	
<b>Analog Switch</b>							
Analog Signal Range <sup>d</sup>	V <sub>ANALOG</sub>	V- = -5 V, V+ = 12 V	Full	-5		8	V
		V- = GND, V+ = 12 V	Full	0		8	
Drain-Source On-Resistance	r <sub>DS(on)</sub>	I <sub>S</sub> = -10 mA, V <sub>D</sub> = 0 V	Room		5	8	Ω
	Full				9		
r <sub>DS(on)</sub> Match	Δr <sub>DS(on)</sub>		Room		0.5	1	
Source Off Leakage Current	I <sub>S(off)</sub>	V <sub>S</sub> = 0 V, V <sub>D</sub> = 10 V	Room	-10	-0.04	10	nA
	Full		Full	-200		200	
Drain Off Leakage Current	I <sub>D(off)</sub>	V <sub>S</sub> = 10 V, V <sub>D</sub> = 0 V	Room	-10	-0.04	10	
	Full		Full	-200		200	
Channel On Leakage Current	I <sub>D(on)</sub>	V <sub>S</sub> = V <sub>D</sub> = 0 V	Room	-10	-0.2	10	
	Full		Full	-200		200	
<b>Digital Control</b>							
Input Voltage High	V <sub>INH</sub>		Full	2.4			V
Input Voltage Low	V <sub>INL</sub>		Full			0.8	
Input Current	I <sub>IN</sub>	V <sub>IN</sub> = GND or V+	Room	-1	0.05	1	μA
	Full		Full	-20		20	
<b>Dynamic Characteristics</b>							
On State Input Capacitance <sup>d</sup>	C <sub>S(on)</sub>	V <sub>S</sub> = V <sub>D</sub> = 0 V	Room		19	40	pF
Off State Input Capacitance <sup>d</sup>	C <sub>S(off)</sub>	V <sub>S</sub> = 0 V	Room		8	20	
Off State Output Capacitance <sup>d</sup>	C <sub>D(off)</sub>	V <sub>D</sub> = 0 V	Room		8	20	
Bandwidth	BW	R <sub>L</sub> = 50 Ω, See Figure 6	Room		500		MHz
Turn On Time	t <sub>ON</sub>	R <sub>L</sub> = 1 kΩ, C <sub>L</sub> = 35 pF, See Figure 2	Room		60	100	ns
	Full			Full		160	
Turn Off Time	t <sub>OFF</sub>		Room		40	60	ns
	Full		Full		100		
Charge Injection	Q	C <sub>L</sub> = 1000 pF, V <sub>D</sub> = 0 V, See Figure 3	Room		-40		pC
Off Isolation		R <sub>IN</sub> = 75 Ω, R <sub>L</sub> = 75 Ω, f = 5 MHz See Figure 4	Room		-63		dB
All Hostile Crosstalk	X <sub>TALK(AH)</sub>	R <sub>IN</sub> = 10 Ω, R <sub>L</sub> = 75 Ω, f = 5 MHz See Figure 5	Room		-85		
<b>Power Supplies</b>							
Positive Supply Current	I+	V <sub>IN</sub> = 0 V or V <sub>IN</sub> = 5 V	Room		3.5	6	mA
	Full			Full		9	
Negative Supply Current	I-		Room	-6	-3		mA
	Full		Full	-9			

Notes:

- Room = 25°C, Full = as determined by the operating temperature suffix.
- Typical values are for DESIGN AID ONLY, not guaranteed nor subject to production testing.
- The algebraic convention whereby the most negative value is a minimum and the most positive a maximum, is used in this data sheet.
- Guaranteed by design, not subject to production test.
- V<sub>IN</sub> = input voltage to perform proper function.

## Typical Characteristics

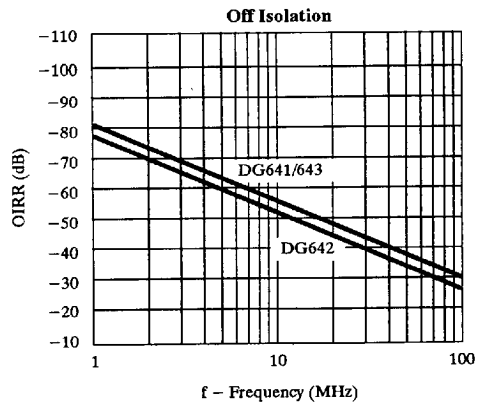
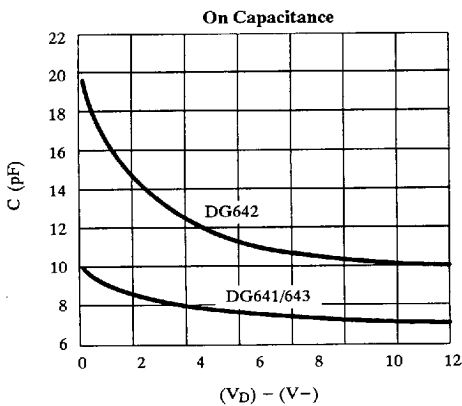
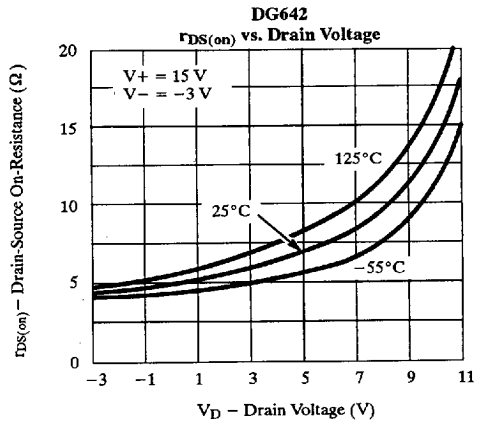
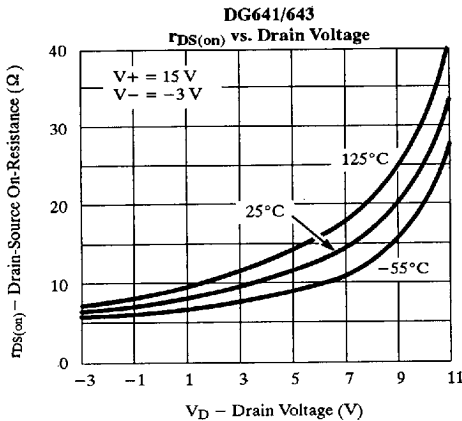
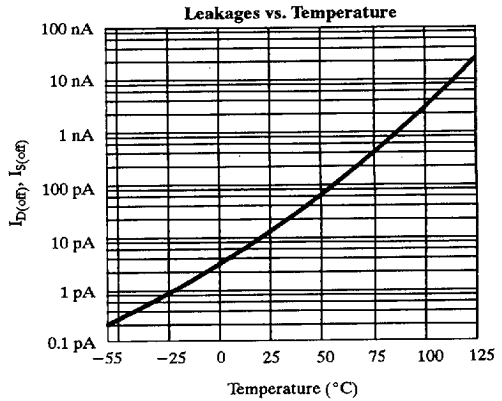
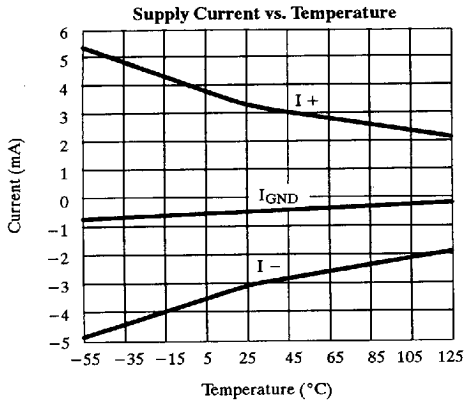

**Typical Characteristics**

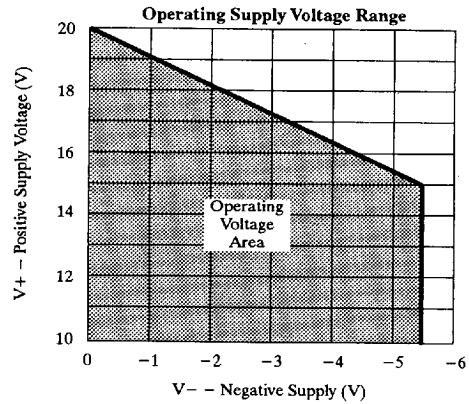
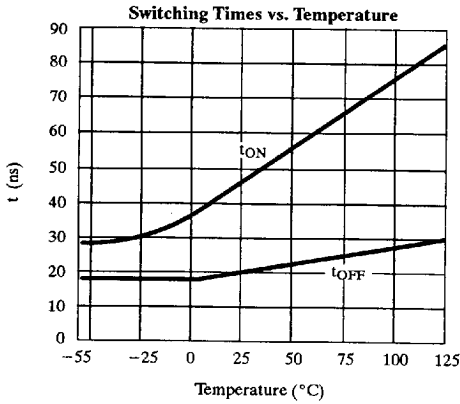
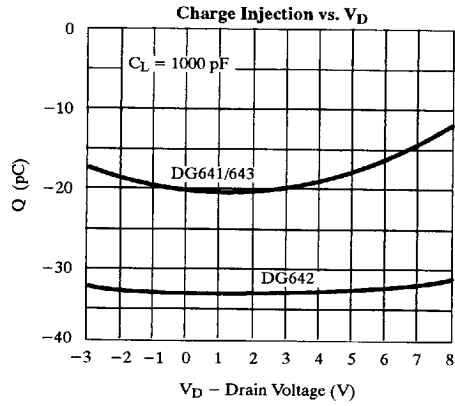
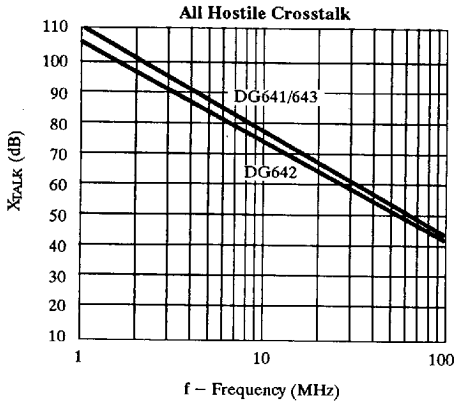

**Schematic Diagram (Typical Channel)**

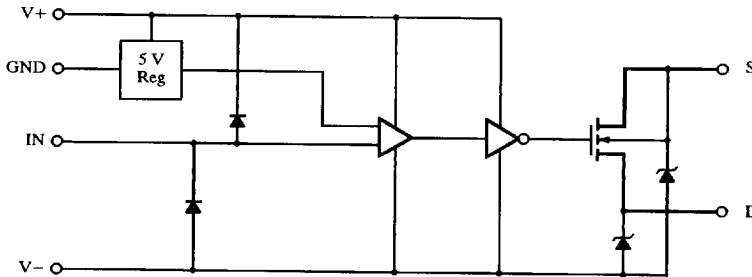

Figure 1.

## Test Circuits

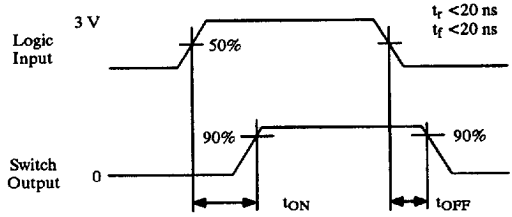
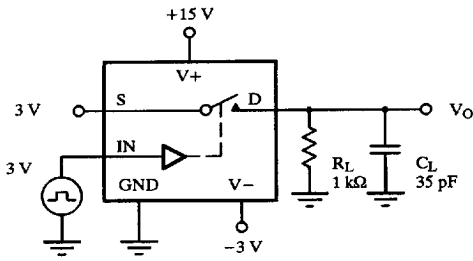
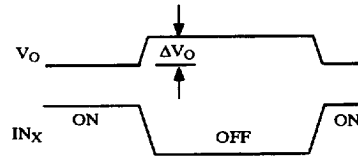
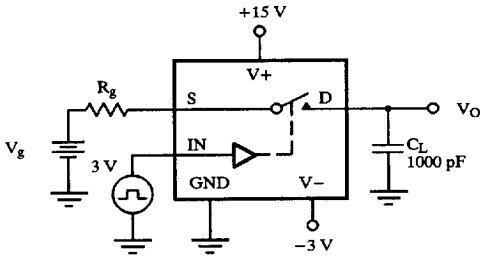
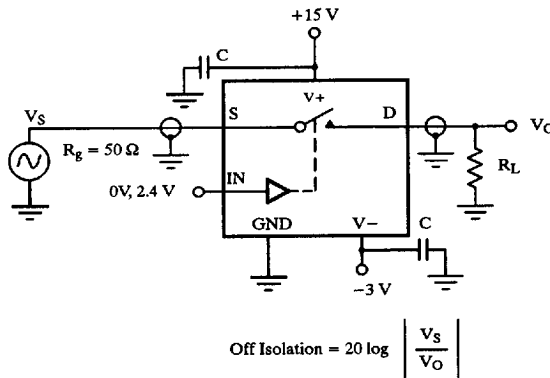

Figure 2. Switching Time



$\Delta V_O$  = measured voltage error due to charge injection  
The charge injection in coulombs is  $Q = C_L \times \Delta V_O$

Figure 3. Charge Injection



$$\text{Off Isolation} = 20 \log \left| \frac{V_S}{V_O} \right|$$

Figure 4. Off Isolation

**Test Circuits**

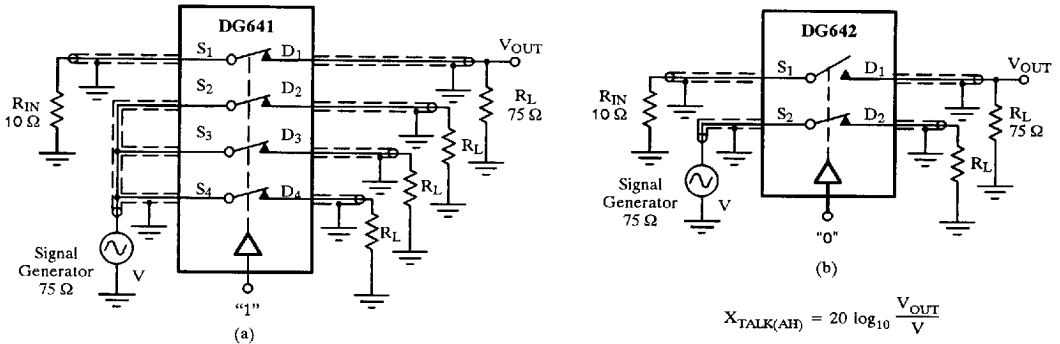

**Figure 5.** All Hostile Crosstalk -  $X_{TALK(AH)}$

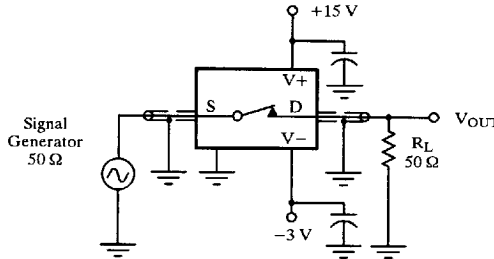

**Figure 6.** Bandwidth

**Applications**

**Device Description**

The DG641/642/643 switches offer true bidirectional switching of high frequency analog or digital signals with minimum signal crosstalk, low insertion loss, and negligible non-linearity distortion and group delay.

Built on the Siliconix D/CMOS process, these switches provide excellent off-isolation with a bandwidth of around 500 MHz. The silicon-gate D/CMOS processing also yields fast switching speeds.

An on-chip regulator circuit maintains TTL input compatibility over the whole operating supply voltage range shown, easing control logic interfacing.

Circuit layout is facilitated by the interchangeability of source and drain terminals.

**Frequency Response**

A single switch on-channel exhibits both resistance [ $r_{DS(on)}$ ] and capacitance [ $C_{S(on)}$ ]. This RC combination has an attenuation effect on the analog signal – which is frequency dependent (like an RC low-pass filter). The -3 dB bandwidth of the DG641/642/643 is typically 500 MHz (into 50  $\Omega$ ).

## Applications (Cont'd)

### Power Supplies

Power supply flexibility is a useful feature of the DG641/642/643 series. It can be operated from a single positive supply (V+) if required (V- connected to ground).

Note that the analog signal must not exceed V- by more than -0.3 V to prevent forward biasing the substrate p-n junction. The use of a V- supply has a number of advantages:

1. It allows flexibility in analog signal handling, i.e., with V- = -5 V and V+ = 12 V; up to  $\pm 5$ -V ac signals can be controlled.
2. The value of on capacitance [ $C_{S(on)}$ ] may be reduced. A property known as 'the body-effect' on the DMOS switch devices causes various parametric effects to occur. One of these effects is the reduction in  $C_{S(on)}$  for an increasing V body-source. Note however that to increase V- normally requires V+ to be reduced (since V+ to V- = 21 V max.). A reduction in V+ causes an increase in  $r_{DS(on)}$ , hence a compromise has to be achieved. It is also useful to note that tests indicate that optimum video linearity performance (e.g., differential phase and gain) occurs when V- is around -3 V.
3. V- eliminates the need to bias the analog signal using potential dividers and large coupling capacitors.

### Decoupling

It is an established rf design practice to incorporate sufficient bypass capacitors in the circuit to decouple the power supplies to all active devices in the circuit. The dynamic performance of the DG641/642/643 series is adversely affected by poor decoupling of power supply pins. Also, of even more significance, since the substrate of the device is connected to the negative supply, adequate decoupling of this pin is essential. Suitable decoupling capacitors are 1- to 10- $\mu$ F tantalum bead, plus 10- to 100-nF ceramic or polyester.

#### Rules:

1. Decoupling capacitors should be incorporated on all power supply pins (V+, V-). (See Figure 7).
2. They should be mounted as close as possible to the device pins.

3. Capacitors should be of a suitable type with good high frequency characteristics - tantalum bead and/or ceramic disc types are adequate.

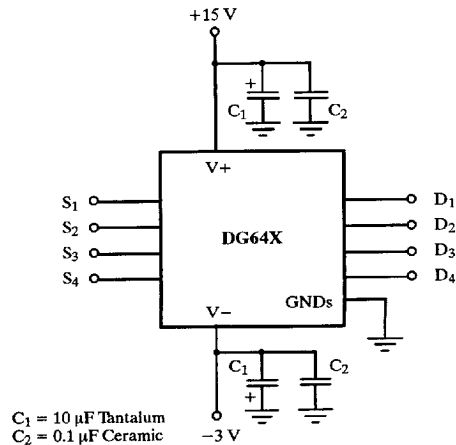

Figure 7. Supply Decoupling

### Board Layout

PCB layout rules for good high frequency performance must also be observed to achieve the performance boasted by these analog switches. Some tips for minimizing stray effects are:

1. Use extensive ground planes on double sided PCB, separating adjacent signal paths. Multilayer PCB is even better.
2. Keep signal paths as short as practically possible, with all channel paths of near equal length.
3. Careful arrangement of ground connections is also very important. Star connected system grounds eliminate signal current, flowing through ground path parasitic resistance, from coupling between channels.

Figure 8 shows a 4-channel video multiplexer using a DG641.

In Figure 9, two coax cables terminated on 75  $\Omega$  bring two video signals to the DG642 switch. The two drains tied together lower the on-state capacitance. An Si582 video amplifier drives a double terminated 75- $\Omega$  cable. The double terminated coax cable eliminates line reflections.

**Applications (Cont'd)**

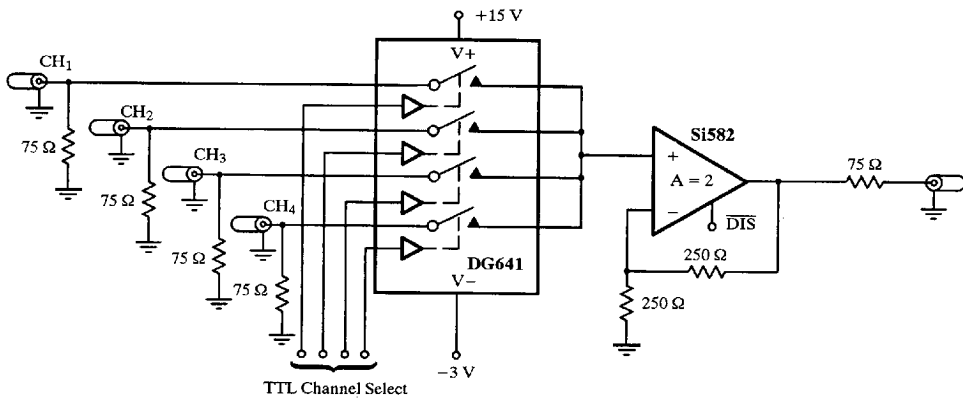

**Figure 8.** 4 by 1 Video Multiplexing Using the DG641

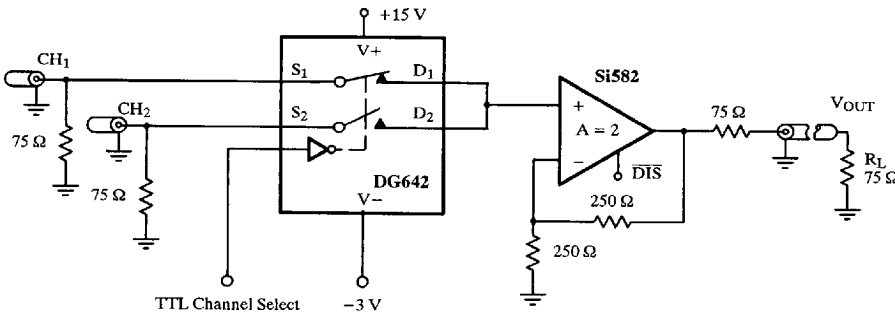

**Figure 9.** 2-Channel Video Selector Using the DG642

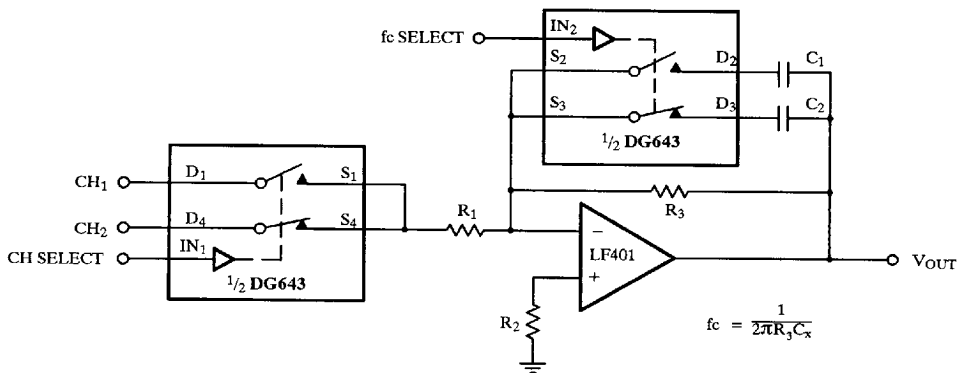

**Figure 10.** Active Low Pass Filter with Selectable Inputs and Break Frequencies

**1**