

**OBSOLETE PRODUCT  
POSSIBLE SUBSTITUTE PRODUCT  
DG442**

**Quad Monolithic SPST, CMOS Analog Switch**

The DG308A quad monolithic SPST, CMOS switch is latch proof and is designed to block signals up to 30V<sub>P-P</sub> when OFF. Featuring low ON resistance, low power consumption, and rail-to-rail analog signal range, this switch is ideally suited for high speed switching applications in communications, instrumentation and process control. The DG308A has single and dual supply capability. The input thresholds are CMOS compatible.

**Features**

- Low Power Consumption
- CMOS Compatible
- ±15V Analog Signal Range
- Single or Dual Supply Capability
- Alternate Source

**Functional Diagram**

**Part Number Information**

PART NUMBER	TEMP. RANGE (°C)	PACKAGE	PKG. NO.
DG308ACJ	0 to 70	16 Ld PDIP	E16.3
DG308ACY	0 to 70	16 Ld SOIC	M16.15

**Pinout**

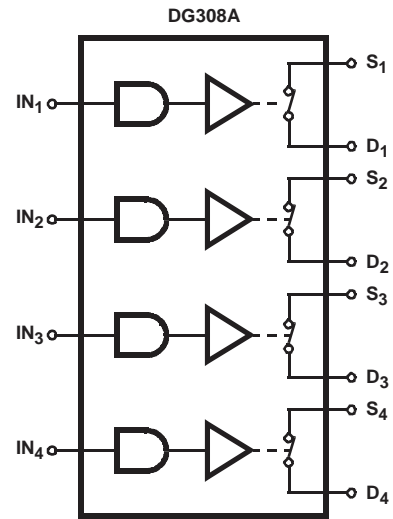
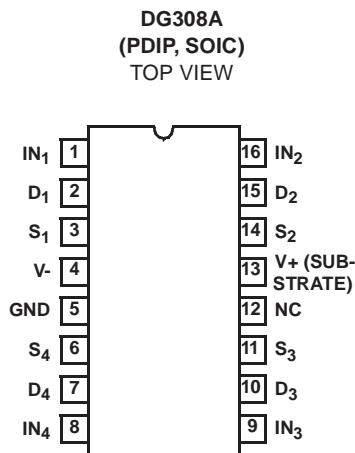

SWITCHES SHOWN FOR LOGIC "1" INPUT

**TRUTH TABLE**

LOGIC	DG308A
0	OFF
1	ON

Logic "0" ≤3.5V, Logic "1" ≥ 11V at V+ = 15V.

**Schematic Diagram** (One Channel)

DG308A

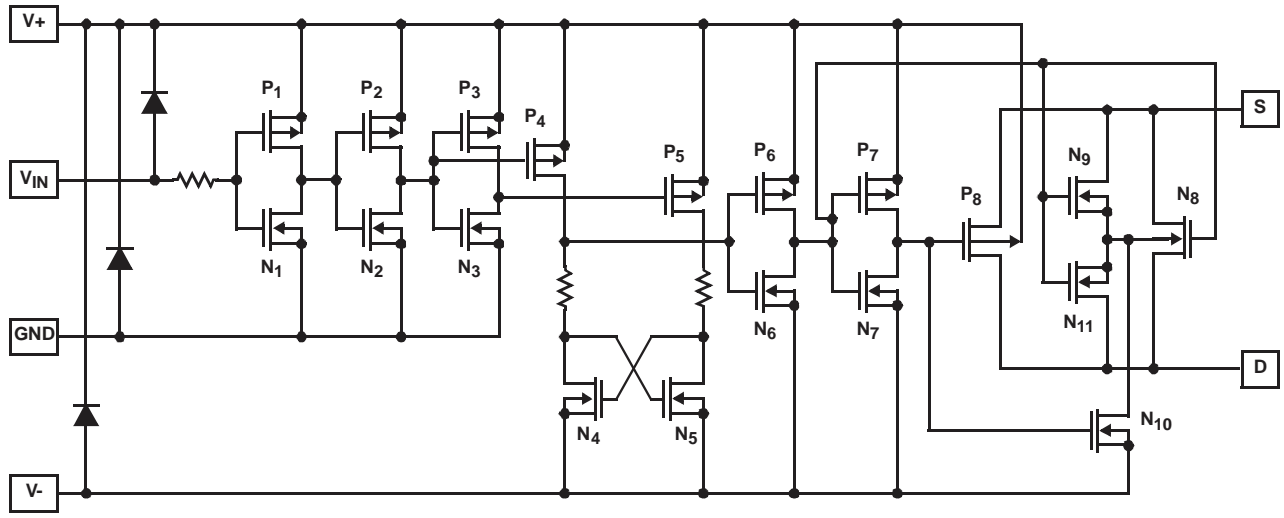

**Absolute Maximum Ratings**

V+ to V- .....	44V
V- to Ground .....	25V
Digital Inputs, V <sub>S</sub> , V <sub>D</sub> (Note 1) .....	(V-) -2V to (V+) +2V or 30mA, Whichever Comes First
Continuous Current, (Any Terminal Except S) .....	30mA
Continuous Current, (S or D) .....	20mA
Peak Current, S or D (Pulsed 1ms, 10% Duty Cycle Max) .....	70mA

**Thermal Information**

Thermal Resistance (Typical, Note 2)	$\theta_{JA}$ (°C/W)
PDIP Package .....	90
SOIC Package .....	115
Maximum Junction Temperature .....	150°C
Maximum Storage Temperature Range .....	65°C to 150°C
Maximum Lead Temperature (Soldering 10s) .....	300°C (SOIC - Lead Tips Only)

**Operating Conditions**

Temperature Range	0°C to 70°C
“C” Suffix .....	0°C to 70°C

*CAUTION: Stresses above those listed in “Absolute Maximum Ratings” may cause permanent damage to the device. This is a stress only rating and operation of the device at these or any other conditions above those indicated in the operational sections of this specification is not implied.*

**NOTES:**

1. Signals on S<sub>X</sub>, D<sub>X</sub>, or I<sub>NX</sub> exceeding V+ or V- will be clamped by internal diodes. Limit forward diode current to maximum current ratings.
2.  $\theta_{JA}$  is measured with the component mounted on an evaluation PC board in free air.

Electrical Specifications V+ = 15V, V- = -15V, GND = 0V, T<sub>A</sub> = 25°C

PARAMETER	TEST CONDITIONS	(NOTE 4) MIN	(NOTE 3) TYP	(NOTE 4) MAX	UNITS	
<b>DYNAMIC CHARACTERISTICS</b>						
Turn-ON Time, t <sub>ON</sub>	See Figure 1	-	130	200	ns	
Turn-OFF Time, t <sub>OFF</sub>	See Figure 1	-	90	150	ns	
Charge Injection, Q	C <sub>L</sub> = 1μF, R <sub>S</sub> = 0, V <sub>S</sub> = 0V	-	-10	-	pC	
OFF Isolation, OIRR	V <sub>IN</sub> = 0V, R <sub>L</sub> = 75Ω, V <sub>S</sub> = 2V <sub>P-P</sub> , f = 500kHz (Note 5)	-	78	-	dB	
Source OFF Capacitance, C <sub>S(OFF)</sub>	f = 140kHz V <sub>S</sub> = 0V V <sub>IN</sub> = 0V	-	11	-	pF	
Drain OFF Capacitance, C <sub>D(OFF)</sub>	V <sub>D</sub> = 0V V <sub>IN</sub> = 0V	-	8	-	pF	
Channel ON Capacitance, C <sub>D(ON)</sub> + C <sub>S(ON)</sub>	V <sub>S</sub> = V <sub>D</sub> = 0V V <sub>IN</sub> = 15V	-	27	-	pF	
<b>DIGITAL INPUT CHARACTERISTICS</b>						
Input Current with Voltage High, I <sub>IH</sub>	V <sub>IN</sub> = 15V, Full Temperature Range	-	0.001	1	μA	
Input Current with Voltage Low, I <sub>IL</sub>	V <sub>IN</sub> = 0V, Full Temperature Range	-1	-0.001	-	μA	
<b>ANALOG SWITCH CHARACTERISTICS</b>						
Analog Signal Range, V <sub>ANALOG</sub>		-15	-	15	V	
Drain-Source ON Resistance, r <sub>DS(ON)</sub>	V <sub>IN</sub> = 11V	I <sub>S</sub> = -1mA, V <sub>D</sub> = +10V	-	60	100	Ω
		I <sub>S</sub> = 1mA, V <sub>D</sub> = -10V	-	60	100	Ω
Source OFF Leakage Current, I <sub>S(OFF)</sub>	V <sub>IN</sub> = 3.5V	V <sub>S</sub> = 14V, V <sub>D</sub> = -14V	-	0.1	5	nA
		V <sub>S</sub> = -14V, V <sub>D</sub> = 14V	-5	-0.1	-	nA
Drain OFF Leakage Current, I <sub>D(OFF)</sub>	V <sub>IN</sub> = 3.5V	V <sub>S</sub> = -14V, V <sub>D</sub> = 14V	-	0.1	5	nA
		V <sub>S</sub> = 14V, V <sub>D</sub> = -14V	-5	-0.1	-	nA
Channel ON Leakage Current, I <sub>D(ON)</sub>	V <sub>IN</sub> = 11V	V <sub>D</sub> = V <sub>S</sub> = 14V	-	0.1	5	nA
		V <sub>D</sub> = V <sub>S</sub> = -14V	-5	-0.1	-	nA

Electrical Specifications  $V_+ = 15V, V_- = -15V, GND = 0V, T_A = 25^\circ C$  (Continued)

PARAMETER	TEST CONDITIONS	(NOTE 4) MIN	(NOTE 3) TYP	(NOTE 4) MAX	UNITS
<b>POWER SUPPLY CHARACTERISTICS</b>					
Positive Supply Current, $I_+$	All Channels ON or OFF $V_{IN} = 0V$ or $15V$	-	0.001	100	$\mu A$
Negative Supply Current, $I_-$		-100	-0.001	-	$\mu A$

NOTES:

- Typical values are for design aid only, not guaranteed and not subject to production testing.
- The algebraic convention whereby the most negative value is a minimum, and the most positive is a maximum, is used in this data sheet.
- OFF isolation =  $20 \text{ Log } V_D/V_S$ , where  $V_S$  = input to OFF switch, and  $V_D$  = output.

**Test Circuit and Waveforms**

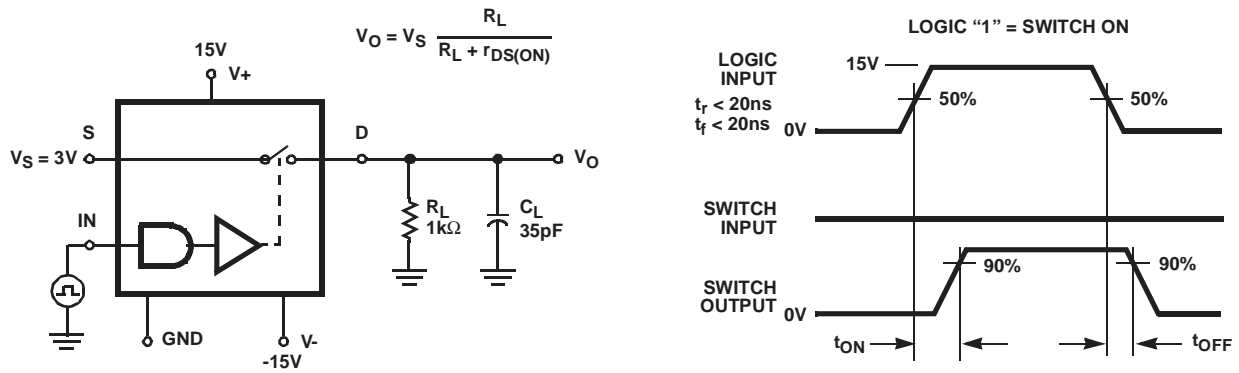

FIGURE 1.  $t_{ON}$  AND  $t_{OFF}$  TEST CIRCUIT AND MEASUREMENT POINTS

**Die Characteristics**

**DIE DIMENSIONS:**

2058 $\mu$ m x 2109 $\mu$ m

**METALLIZATION:**

Type: Al

Thickness: 10k $\text{\AA}$   $\pm$  1k $\text{\AA}$

**PASSIVATION:**

Type: PSG Over Nitride

PSG Thickness: 7k $\text{\AA}$   $\pm$  1.4k $\text{\AA}$

Nitride Thickness: 8k $\text{\AA}$   $\pm$  1.2k $\text{\AA}$

**WORST CASE CURRENT DENSITY:**

9.1 x 10<sup>4</sup> A/cm<sup>2</sup>

**Metallization Mask Layout**

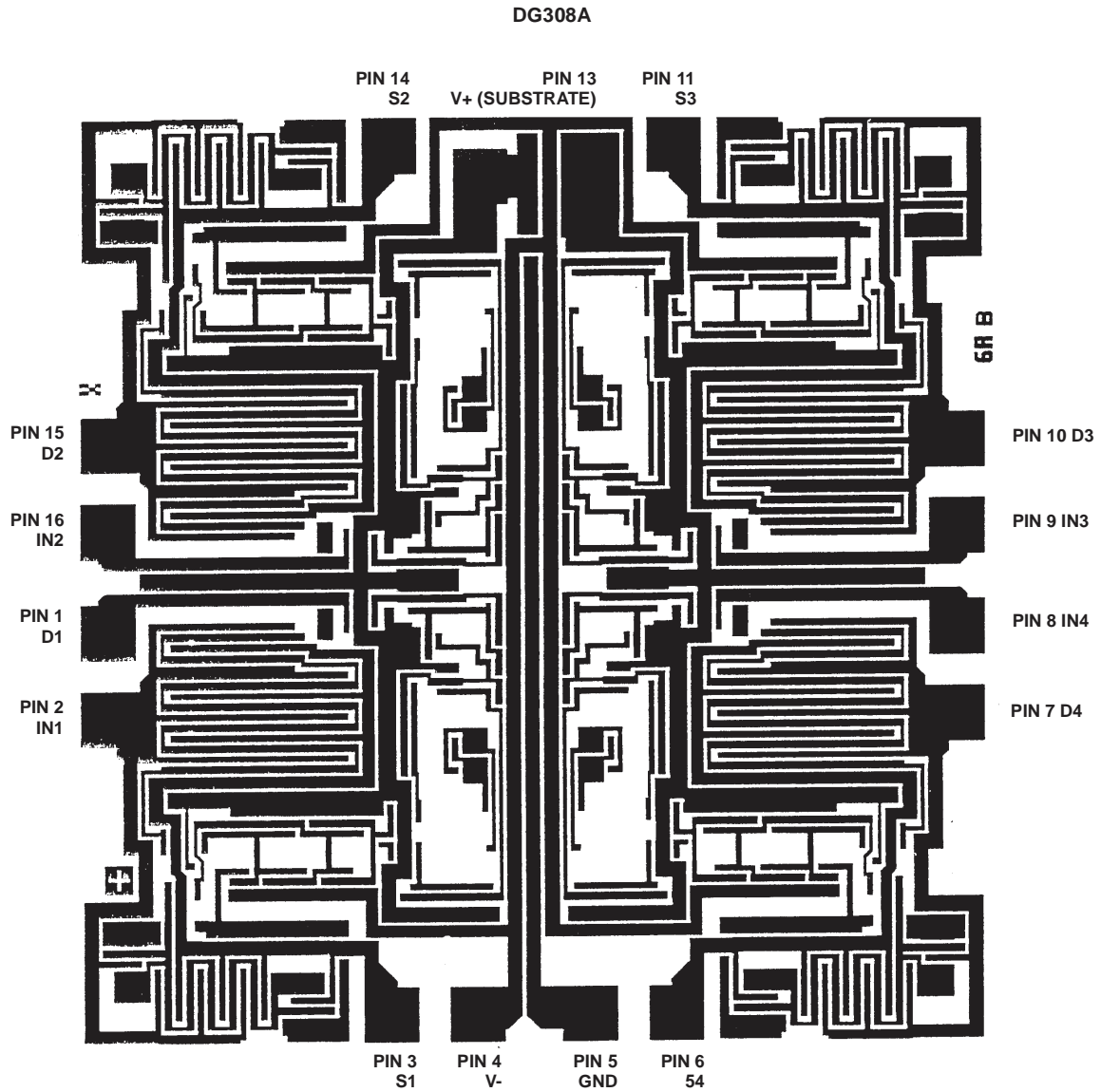

Dual-In-Line Plastic Packages (PDIP)

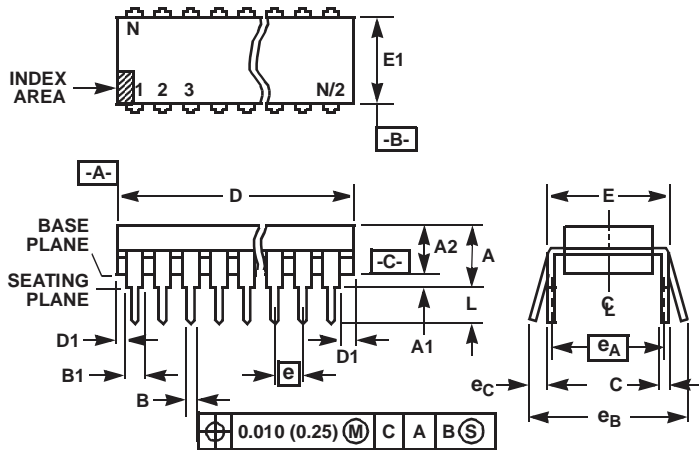

NOTES:

- Controlling Dimensions: INCH. In case of conflict between English and Metric dimensions, the inch dimensions control.
- Dimensioning and tolerancing per ANSI Y14.5M-1982.
- Symbols are defined in the "MO Series Symbol List" in Section 2.2 of Publication No. 95.
- Dimensions A, A1 and L are measured with the package seated in JEDEC seating plane gauge GS-3.
- D, D1, and E1 dimensions do not include mold flash or protrusions. Mold flash or protrusions shall not exceed 0.010 inch (0.25mm).
- E and  $e_A$  are measured with the leads constrained to be perpendicular to datum [-C-].
- $e_B$  and  $e_C$  are measured at the lead tips with the leads unconstrained.  $e_C$  must be zero or greater.
- B1 maximum dimensions do not include dambar protrusions. Dambar protrusions shall not exceed 0.010 inch (0.25mm).
- N is the maximum number of terminal positions.
- Corner leads (1, N, N/2 and N/2 + 1) for E8.3, E16.3, E18.3, E28.3, E42.6 will have a B1 dimension of 0.030 - 0.045 inch (0.76 - 1.14mm).

E16.3 (JEDEC MS-001-BB ISSUE D)  
16 LEAD DUAL-IN-LINE PLASTIC PACKAGE

SYMBOL	INCHES		MILLIMETERS		NOTES
	MIN	MAX	MIN	MAX	
A	-	0.210	-	5.33	4
A1	0.015	-	0.39	-	4
A2	0.115	0.195	2.93	4.95	-
B	0.014	0.022	0.356	0.558	-
B1	0.045	0.070	1.15	1.77	8, 10
C	0.008	0.014	0.204	0.355	-
D	0.735	0.775	18.66	19.68	5
D1	0.005	-	0.13	-	5
E	0.300	0.325	7.62	8.25	6
E1	0.240	0.280	6.10	7.11	5
e	0.100 BSC		2.54 BSC		-
$e_A$	0.300 BSC		7.62 BSC		6
$e_B$	-	0.430	-	10.92	7
L	0.115	0.150	2.93	3.81	4
N	16		16		9

Rev. 0 12/93

**Small Outline Plastic Packages (SOIC)**

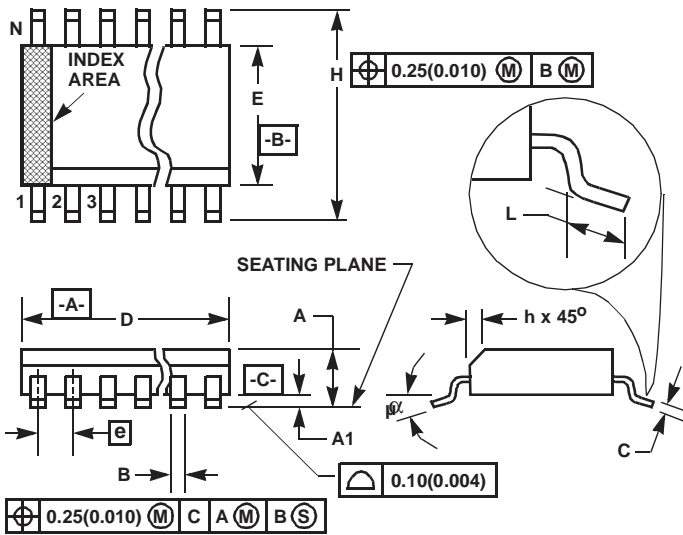

**M16.15 (JEDEC MS-012-AC ISSUE C)**  
**16 LEAD NARROW BODY SMALL OUTLINE PLASTIC PACKAGE**

SYMBOL	INCHES		MILLIMETERS		NOTES
	MIN	MAX	MIN	MAX	
A	0.0532	0.0688	1.35	1.75	-
A1	0.0040	0.0098	0.10	0.25	-
B	0.013	0.020	0.33	0.51	9
C	0.0075	0.0098	0.19	0.25	-
D	0.3859	0.3937	9.80	10.00	3
E	0.1497	0.1574	3.80	4.00	4
e	0.050 BSC		1.27 BSC		-
H	0.2284	0.2440	5.80	6.20	-
h	0.0099	0.0196	0.25	0.50	5
L	0.016	0.050	0.40	1.27	6
N	16		16		7
$\alpha$	0°	8°	0°	8°	-

Rev. 0 12/93

**NOTES:**

1. Symbols are defined in the "MO Series Symbol List" in Section 2.2 of Publication Number 95.
2. Dimensioning and tolerancing per ANSI Y14.5M-1982.
3. Dimension "D" does not include mold flash, protrusions or gate burrs. Mold flash, protrusion and gate burrs shall not exceed 0.15mm (0.006 inch) per side.
4. Dimension "E" does not include interlead flash or protrusions. Interlead flash and protrusions shall not exceed 0.25mm (0.010 inch) per side.
5. The chamfer on the body is optional. If it is not present, a visual index feature must be located within the crosshatched area.
6. "L" is the length of terminal for soldering to a substrate.
7. "N" is the number of terminal positions.
8. Terminal numbers are shown for reference only.
9. The lead width "B", as measured 0.36mm (0.014 inch) or greater above the seating plane, shall not exceed a maximum value of 0.61mm (0.024 inch).
10. Controlling dimension: MILLIMETER. Converted inch dimensions are not necessarily exact.

All Intersil products are manufactured, assembled and tested utilizing ISO9000 quality systems.

Intersil Corporation's quality certifications can be viewed at website [www.intersil.com/design/quality/iso.asp](http://www.intersil.com/design/quality/iso.asp)

*Intersil products are sold by description only. Intersil Corporation reserves the right to make changes in circuit design and/or specifications at any time without notice. Accordingly, the reader is cautioned to verify that data sheets are current before placing orders. Information furnished by Intersil is believed to be accurate and reliable. However, no responsibility is assumed by Intersil or its subsidiaries for its use; nor for any infringements of patents or other rights of third parties which may result from its use. No license is granted by implication or otherwise under any patent or patent rights of Intersil or its subsidiaries.*

For information regarding Intersil Corporation and its products, see web site [www.intersil.com](http://www.intersil.com)

**Sales Office Headquarters**

**NORTH AMERICA**  
 Intersil Corporation  
 2401 Palm Bay Rd.  
 Palm Bay, FL 32905  
 TEL: (321) 724-7000  
 FAX: (321) 724-7240

**EUROPE**  
 Intersil SA  
 Mercure Center  
 100, Rue de la Fusee  
 1130 Brussels, Belgium  
 TEL: (32) 2.724.2111  
 FAX: (32) 2.724.22.05

**ASIA**  
 Intersil Ltd.  
 8F-2, 96, Sec. 1, Chien-kuo North,  
 Taipei, Taiwan 104  
 Republic of China  
 TEL: 886-2-2515-8508  
 FAX: 886-2-2515-8369