

Camera Module Sockets

Table of Product

Applicable Module Size	Type	Part No.	Page
5X5	On Board	CLE9120-1801F	3
	On Board	CLE9120-2701F	3
	Through Board	CLE9120-2601F	3
5.8X5.8	On Board	CLE9124-1601F	4
6X6	On Board	CLE9120-0501F	4
	Top Shield	CLE9020-0603F	4
	On Board	CLE9120-1001F	5
	Top Shield	CLE9120-2201F	5
	Through Board	CLE9020-0801F	5
6.5X6.5	On Board	CLE9124-6901F	6
7X7	On Board	CLE9128-4001F	6
8X8	On Board	CLE9124-1501F	6
	On Board	CLE9124-1502F	7
	On Board	CLE9124-4501F	7
	Top Shield	CLE9124-1401F	7
	Through Board	CLE9124-3801F	8
8.5X8.5	On Board	CLE9124-4801F	8
10X10	On Board	CLE9028-0201F	9
11.5X13.5	On Board	CLE9130-2801F	9
11.5X11.5	On Board	CLE9130-4901F	9
SMIA65	On Board	CLE9112-1101F	10
	Through Board	CLE9112-2301F	10
SMIA85	On Board	CLE9014-1301F	10
	Through Board	CLE9114-1201F	11
SMIA95	On Board	CLE9016-0101F	11

Features

- 1.Highly reliable contact and locking structures.
 - 2.Designed for ensured shielding performance.
 - 3.Shorter assembly time and easier assemblability than FPC mounted solution.
- *Patents pending.

Specification

- Rating0.5A, 50V AC/DC
- Contct Resistance30mΩ, max.
- Insulation Resistance100MΩmin. at 100V DC
- Withstanding Voltage.....100V AC (for one minute)
- Operating Temperature Range-30°C to +85°C

Application

Mobile phones, PHS, Equipments for games, etc

for 5X5 Size Camera Module

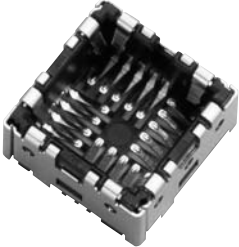
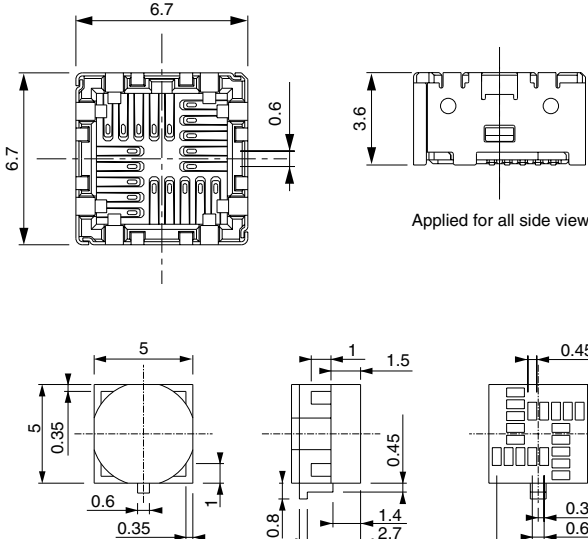
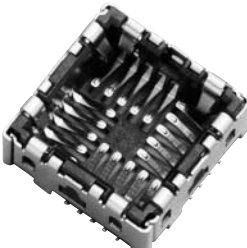
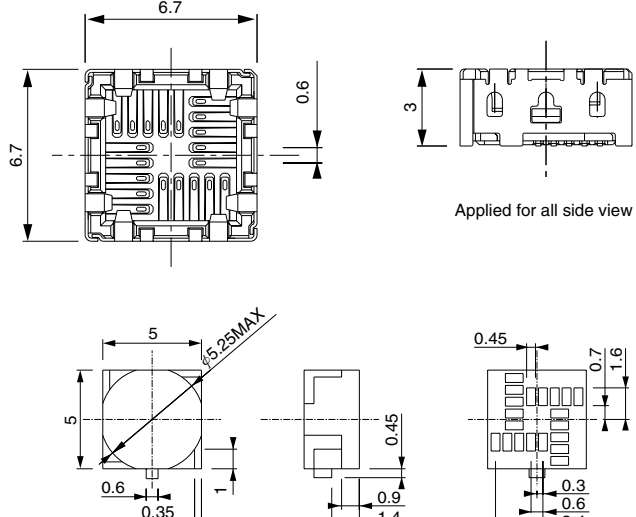
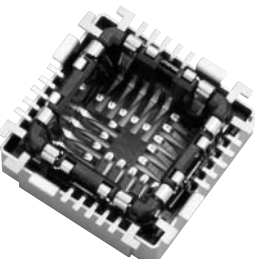
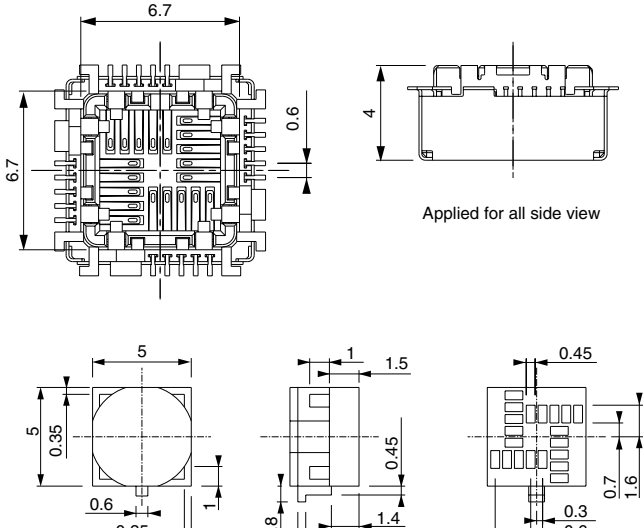
<p style="text-align: center;">CLE9120-1801F</p> 	<p>■Dimension</p>  <p>Applied for all side view</p> <p>■Applicable Module Size</p>
<p style="text-align: center;">On Board Type</p>	
<p style="text-align: center;">CLE9120-2701F</p> 	<p>■Dimension</p>  <p>Applied for all side view</p> <p>■Applicable Module Size</p>
<p style="text-align: center;">On Board Type</p>	
<p style="text-align: center;">CLE9120-2601F</p> 	<p>■Dimension</p>  <p>Applied for all side view</p> <p>■Applicable Module Size</p>
<p style="text-align: center;">Through Board Type</p>	

for 5.8X5.8 Size Camera Module

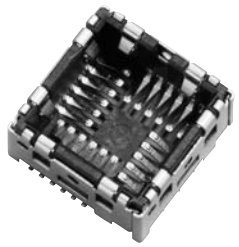
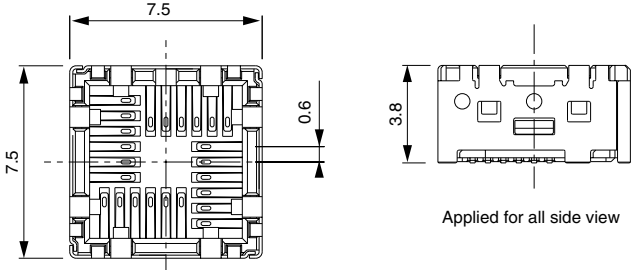
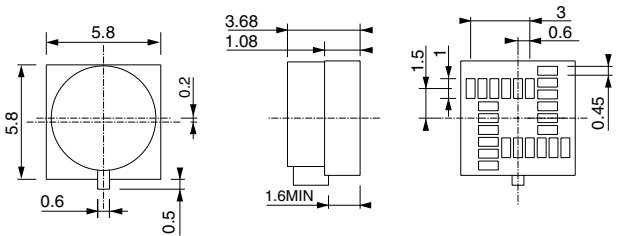
<p>CLE9124-1601F</p> 	<p>■Dimension</p>  <p>Applied for all side view</p> <p>■Applicable Module Size</p> 
<p>On Board Type</p>	

for 6X6 Size Camera Module

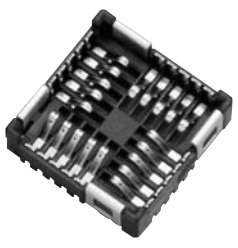
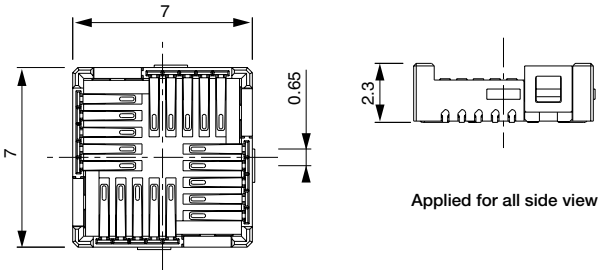
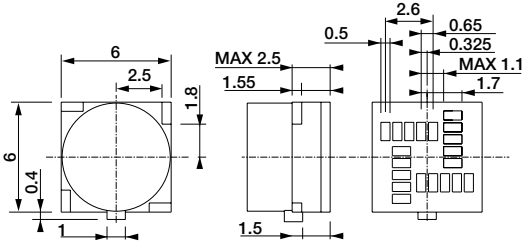
<p>CLE9120-0501F</p> 	<p>■Dimension</p>  <p>Applied for all side view</p> <p>■Applicable Module Size</p> 
<p>On Board Type</p>	

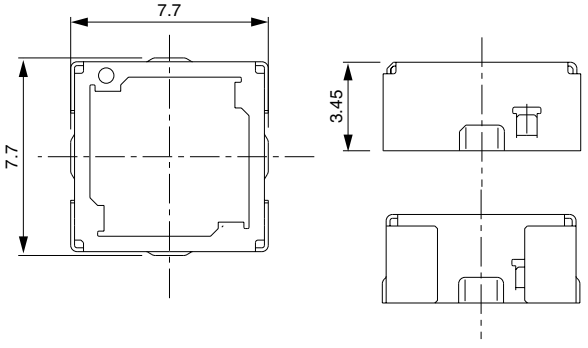
<p>CLE9020-0603F</p> 	<p>■Dimension</p>  <p>■Applicable Part No. (Socket)</p> <p>CLE9020-0501F</p>
<p>Top Shield</p>	

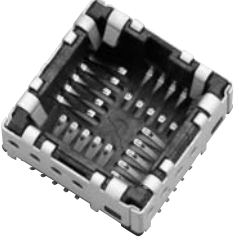
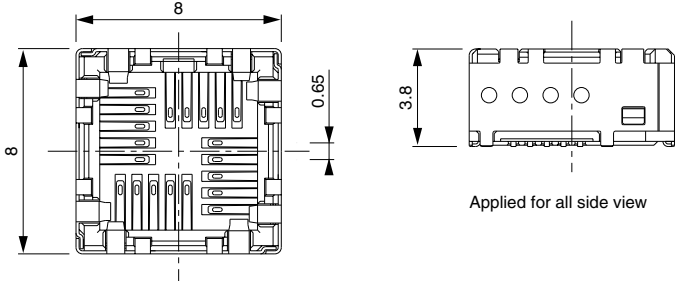
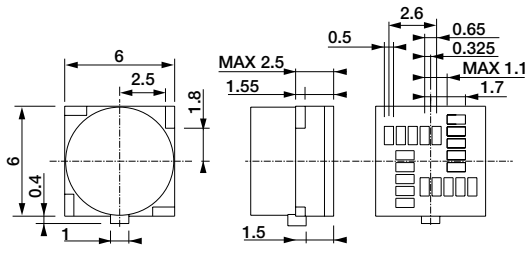
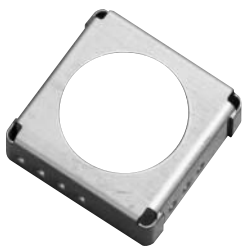
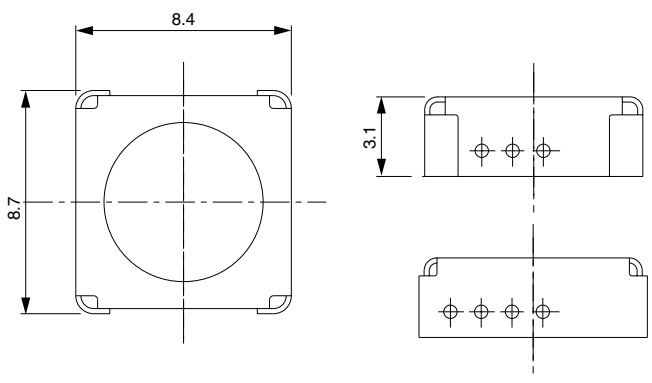
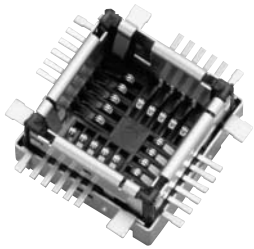
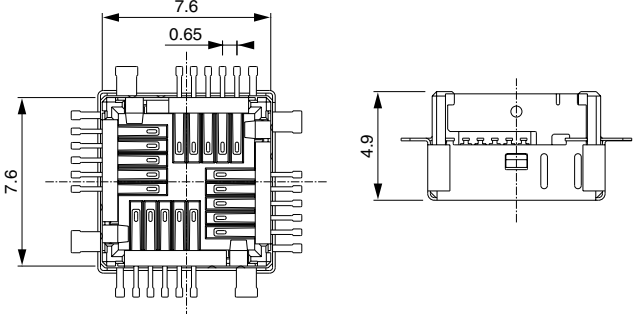
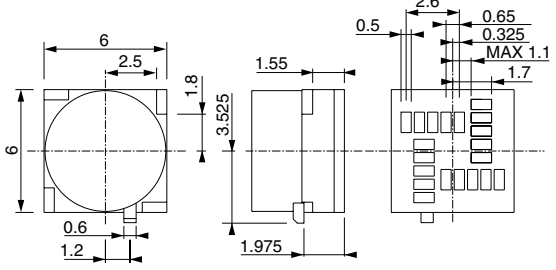
<p style="text-align: center;">CLE9120-1001F</p> 	<p>■Dimension</p>  <p style="text-align: right;">Applied for all side view</p> <p>■Applicable Module Size</p> 
<p style="text-align: center;">On Board Type</p>	
<p style="text-align: center;">CLE9120-2201F</p> 	<p>■Dimension</p>  <p>■Applicable Part No. (Socket)</p> <p style="text-align: center;">CLE9120-1001F</p>
<p style="text-align: center;">Top Shield</p>	
<p style="text-align: center;">CLE9020-0801F</p> 	<p>■Dimension</p>  <p>■Applicable Module Size</p> 
<p style="text-align: center;">Through Board Type</p>	

for 6.5X6.5 Size Camera Module

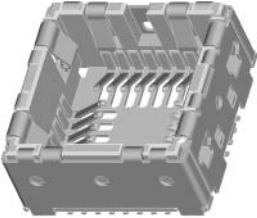
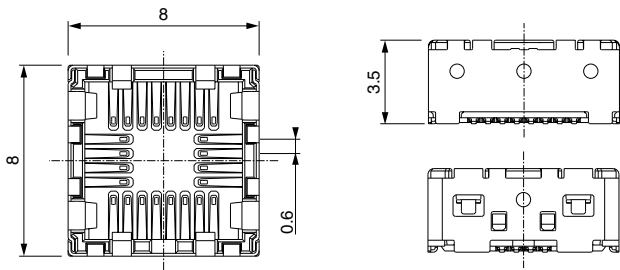
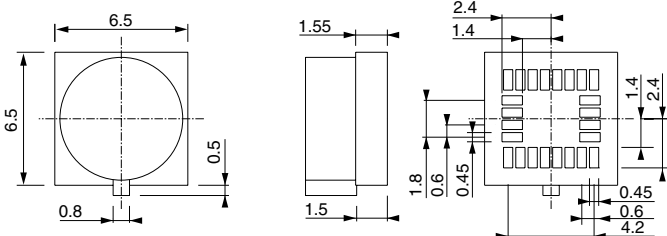
<p>CLE9124-6901F</p> 	<p>■Dimension</p>  <p>■Applicable Module Size</p> 
<p>On Board Type</p>	

for 7X7 Size Camera Module

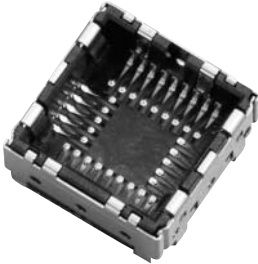
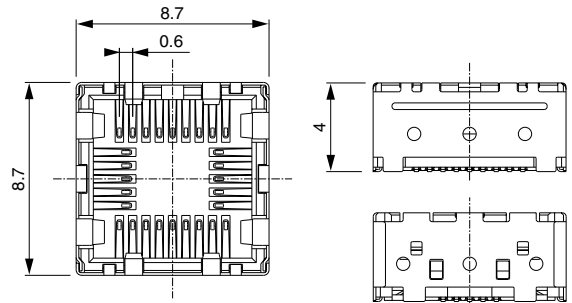
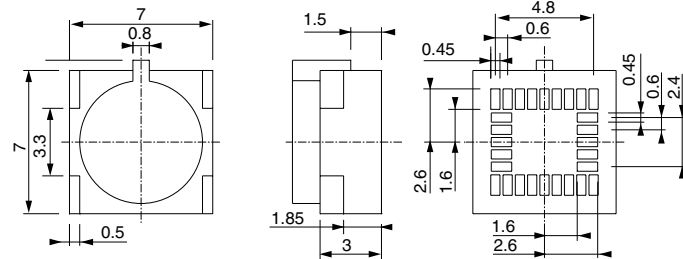
<p>CLE9128-4001F</p> 	<p>■Dimension</p>  <p>■Applicable Module Size</p> 
<p>On Board Type</p>	

for 8X8 Size Camera Module

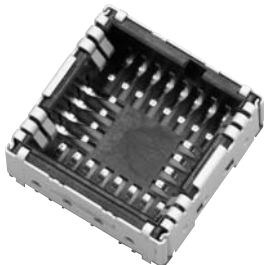
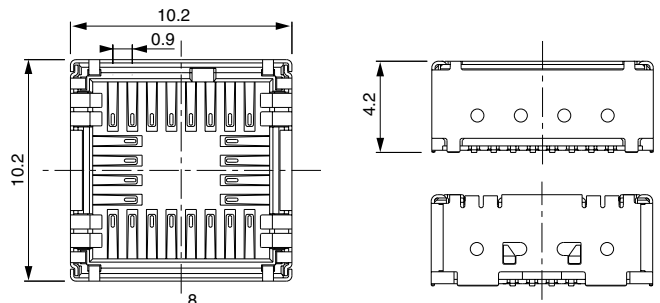
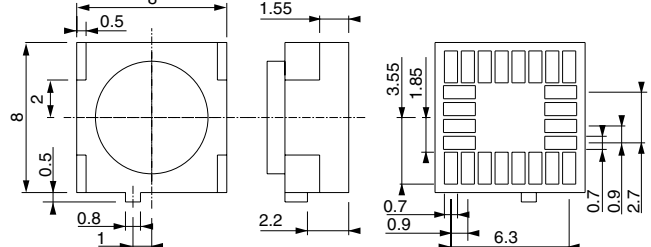
<p>CLE9124-1501F</p> 	<p>■Dimension</p>  <p>■Applicable Module Size</p> 
<p>On Board Type</p>	

<p>CLE9124-1502F</p>	<p>■Dimension</p> <p>■Applicable Module Size</p>
<p>On Board Type</p>	
<p>CLE9124-4501F</p>	<p>■Dimension</p> <p>■Applicable Module Size</p>
<p>On Board Type</p>	
<p>CLE9124-1401F</p>	<p>■Dimension</p> <p>■Applicable Part No. (Socket)</p> <p>CLE9124-1501F CLE9124-1502F</p>
<p>Top Shield</p>	

CLE9124-3801F	<p>■Dimension</p>
	<p>■Applicable Module Size</p>
Through Board Type	

for 8.5X8.5 Size Camera Module

CLE9124-4801F	<p>■Dimension</p>
	<p>■Applicable Module Size</p>
On Board Type	

for 10X10 Size Camera Module

CLE9028-0201F	<p>■Dimension</p>
	<p>■Applicable Module Size</p>
On Board Type	

for 11.5X13.5 Size Camera Module

CLE9130-2801F	<p>■Dimension</p>
	<p>■Applicable Module Size</p>
On Board Type	

for 11.5X11.5 Size Camera Module

CLE9130-4901F	<p>■Dimension</p>
	<p>■Applicable Module Size</p>
On Board Type	

for SMIA65

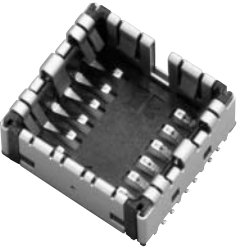
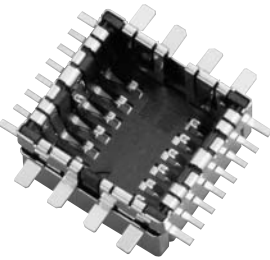
<p>CLE9112-1101F</p> 	<p>■Dimension</p> <p>■Applicable Module Size</p>
<p>On Board Type</p>	
<p>CLE9112-2301F</p> 	<p>■Dimension</p> <p>■Applicable Module Size</p>
<p>Through Board</p>	

for SMIA85

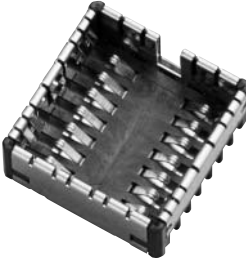
<p>CLE9014-1301F</p> 	<p>■Dimension</p> <p>■Applicable Module Size</p>
<p>On Board Type</p>	

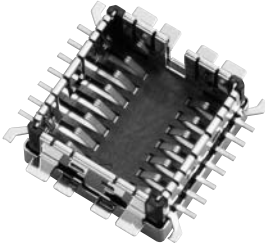
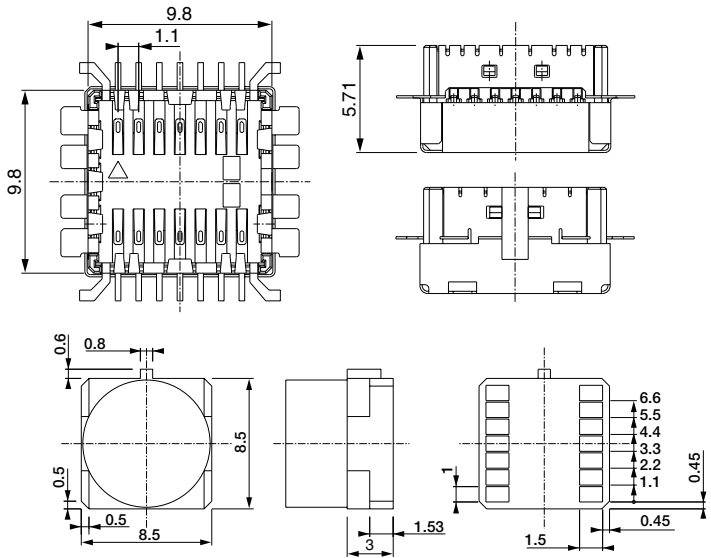
<p style="text-align: center;">CLE9114-1201F</p> 	<p>■Dimension</p>  <p>■Applicable Module Size</p>
<p style="text-align: center;">Through Board</p>	

for SMIA95

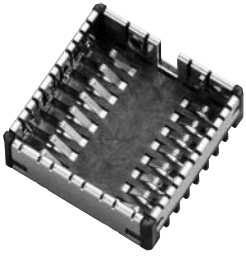
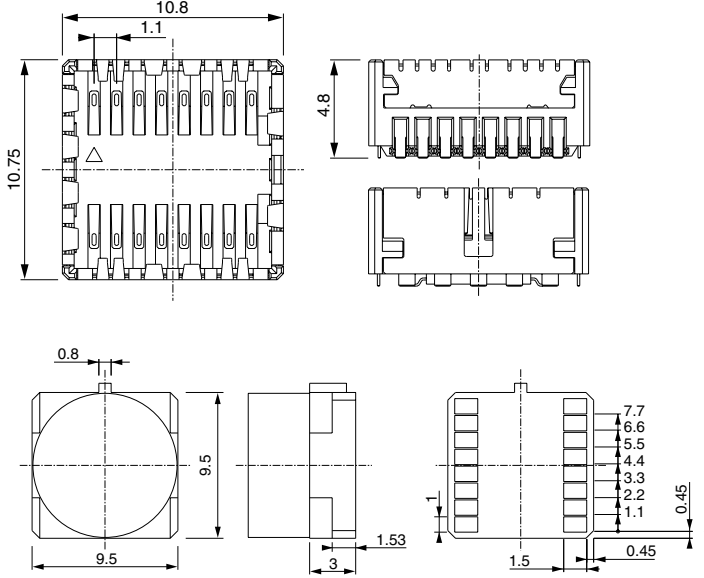
<p style="text-align: center;">CLE9016-0101F</p> 	<p>■Dimension</p>  <p>■Applicable Module Size</p>
<p style="text-align: center;">On Board type</p>	