



CY62256V

## 256K (32K x 8) Static RAM

## Features

- **Temperature Ranges**
  - Commercial: 0°C to 70°C
  - Industrial: -40°C to 85°C
  - Automotive: -40°C to 125°C
- **Speed: 70 ns and 100 ns**
- **Low voltage range:**
  - CY62256V (2.7V–3.6V)
  - CY62256V25 (2.3V–2.7V)
- **Low active power and standby power**
- **Easy memory expansion with CE and OE features**
- **TTL-compatible inputs and outputs**
- **Automatic power-down when deselected**
- **CMOS for optimum speed/power**
- **Package available in a standard 450-mil-wide (300-mil body width) 28-lead narrow SOIC, 28-lead TSOP-1, and reverse 28-lead TSOP-1 package**

Functional Description<sup>[1]</sup>

The CY62256V family is composed of two high-performance CMOS static RAM's organized as 32K words by 8 bits. Easy memory expansion is provided by an active LOW chip enable (CE) and active LOW output enable (OE) and three-state drivers. These devices have an automatic power-down feature, reducing the power consumption by over 99% when deselected.

An active LOW write enable signal ( $\overline{WE}$ ) controls the writing/reading operation of the memory. When CE and WE inputs are both LOW, data on the eight data input/output pins (I/O<sub>0</sub> through I/O<sub>7</sub>) is written into the memory location addressed by the address present on the address pins (A<sub>0</sub> through A<sub>14</sub>). Reading the device is accomplished by selecting the device and enabling the outputs, CE and OE active LOW, while  $\overline{WE}$  remains inactive or HIGH. Under these conditions, the contents of the location addressed by the information on address pins are present on the eight data input/output pins.

The input/output pins remain in a high-impedance state unless the chip is selected, outputs are enabled, and write enable ( $\overline{WE}$ ) is HIGH.

## Logic Block Diagram

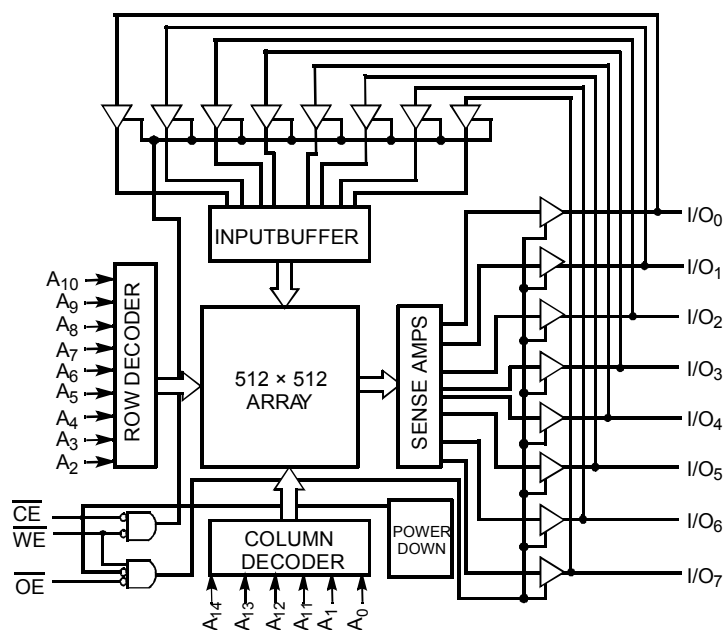

## Note:

1. For best practice recommendations, please refer to the Cypress application note "System Design Guidelines" on <http://www.cypress.com>.



## Product Portfolio

Product	Range	V <sub>CC</sub> Range (V)			Speed (ns)	Power Dissipation			
		Min.	Typ. <sup>[2]</sup>	Max.		Operating, I <sub>CC</sub> (mA)		Standby, I <sub>SB2</sub> (μA)	
						Typ. <sup>[2]</sup>	Max.	Typ. <sup>[2]</sup>	Max.
CY62256VLL	Com'l / Ind'l	2.7	3.0	3.6	70	11	30	0.1	5
CY62256VLL	Automotive	2.7	3.0	3.6	70	11	30	0.1	130
CY62256V25LL	Com'l	2.3	2.5	2.7	100	9	15	0.1	4

## Pin Configurations

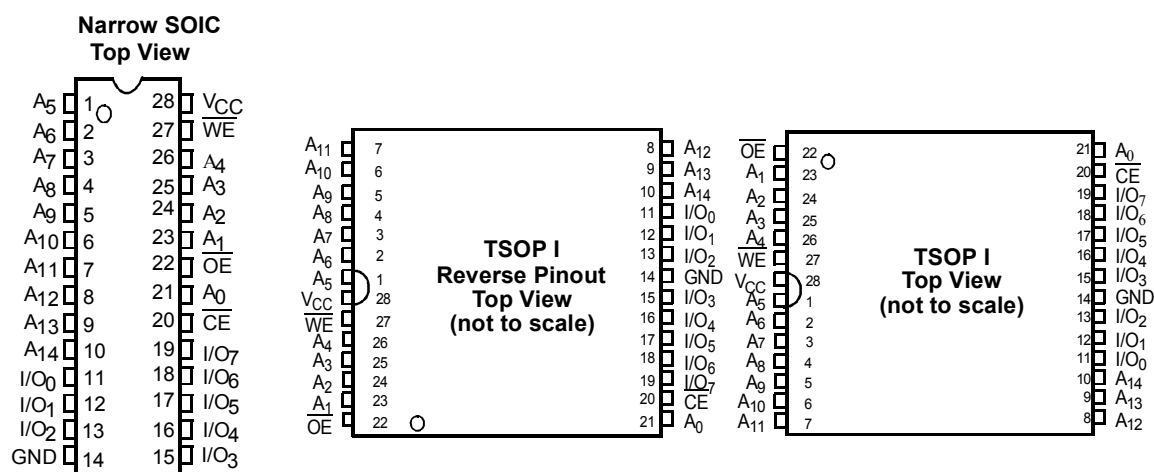

## Pin Definitions

Pin Number	Type	Description
1-10, 21, 23-26	Input	<b>A<sub>0</sub>-A<sub>14</sub></b> . Address Inputs
11-13, 15-19	Input/Output	<b>I/O<sub>0</sub>-I/O<sub>7</sub></b> . Data lines. Used as input or output lines depending on operation
27	Input/Control	<b>WE</b> . When selected LOW, a WRITE is conducted. When selected HIGH, a READ is conducted
20	Input/Control	<b>CE</b> . When LOW, selects the chip. When HIGH, deselects the chip
22	Input/Control	<b>OE</b> . Output Enable. Controls the direction of the I/O pins. When LOW, the I/O pins behave as outputs. When deasserted HIGH, I/O pins are three-stated, and act as input data pins
14	Ground	<b>GND</b> . Ground for the device
28	Power Supply	<b>V<sub>CC</sub></b> . Power supply for the device

## Notes:

2. Typical values are included for reference only and are not guaranteed or tested. Typical values are measured at V<sub>CC</sub> = V<sub>CC</sub> Typ., T<sub>A</sub> = 25°C, and t<sub>AA</sub> = 70 ns.



## CY62256V

### Maximum Ratings

(Above which the useful life may be impaired. For user guidelines, not tested.)

Storage Temperature ..... -65°C to +150°C

Ambient Temperature with Power Applied ..... -55°C to +125°C

Supply Voltage to Ground Potential (Pin 28 to Pin 14) ..... -0.5V to +4.6V

DC Voltage Applied to Outputs in High-Z State<sup>[3]</sup> ..... -0.5V to  $V_{CC} + 0.5V$

DC Input Voltage<sup>[3]</sup> ..... -0.5V to  $V_{CC} + 0.5V$

Output Current into Outputs (LOW) ..... 20 mA

Static Discharge Voltage ..... > 2001V (per MIL-STD-883, Method 3015)

Latch-up Current ..... > 200 mA

### Operating Range

Device	Range	Ambient Temperature ( $T_A$ ) <sup>[4]</sup>	$V_{CC}$
CY62256V	Commercial	0°C to +70°C	2.7V to 3.6V
	Industrial	-40°C to +85°C	
	Automotive	-40°C to +125°C	
CY62256V25	Commercial	0°C to +70°C	2.3V to 2.7V

### Electrical Characteristics Over the Operating Range

Parameter	Description	Test Conditions	CY62256V-70			Unit
			Min.	Typ. <sup>[2]</sup>	Max.	
$V_{OH}$	Output HIGH Voltage	$I_{OH} = -1.0 \text{ mA}$ , $V_{CC} = 2.7V$	2.4			V
$V_{OL}$	Output LOW Voltage	$I_{OL} = 2.1 \text{ mA}$ , $V_{CC} = 2.7V$			0.4	V
$V_{IH}$	Input HIGH Voltage		2.2		$V_{CC} + 0.3V$	V
$V_{IL}$	Input Leakage Voltage		-0.5		0.8	V
$I_{IX}$	Input Leakage Current	$GND \leq V_{IN} \leq V_{CC}$	Com'l, Ind'l	-1	+1	$\mu A$
			Automotive	-10	+10	$\mu A$
$I_{OZ}$	Output Leakage Current	$GND \leq V_{IN} \leq V_{CC}$ , Output Disabled	Com'l, Ind'l	-1	+1	$\mu A$
			Automotive	-10	+10	$\mu A$
$I_{CC}$	$V_{CC}$ Operating Supply Current	$V_{CC} = 3.6V$ , $I_{OUT} = 0 \text{ mA}$ , $f = f_{MAX} = 1/t_{RC}$		11	30	mA
$I_{SB1}$	Automatic CE Power-down Current— TTL Inputs	$V_{CC} = 3.6V$ , $CE \geq V_{IH}$ , $V_{IN} \geq V_{IH}$ or $V_{IN} \leq V_{IL}$ , $f = f_{MAX}$		100	300	$\mu A$
$I_{SB2}$	Automatic CE Power-down Current— CMOS Inputs	$V_{CC} = 3.6V$ , $CE \geq V_{CC} - 0.3V$ , $V_{IN} \geq V_{CC} - 0.3V$ or $V_{IN} \leq 0.3V$ , $f = 0$	Com'l	0.1	5	$\mu A$
			Ind'l		10	
			Automotive		130	

### Electrical Characteristics Over the Operating Range

Parameter	Description	Test Conditions	CY62256V25-100			Unit
			Min.	Typ. <sup>[2]</sup>	Max.	
$V_{OH}$	Output HIGH Voltage	$I_{OH} = -0.1 \text{ mA}$ , $V_{CC} = 2.3V$	2			V
$V_{OL}$	Output LOW Voltage	$I_{OL} = 0.1 \text{ mA}$ , $V_{CC} = 2.3V$			0.4	V
$V_{IH}$	Input HIGH Voltage		1.7		$V_{CC} + 0.3V$	V
$V_{IL}$	Input LOW Voltage		-0.3		0.7	V
$I_{IX}$	Input Leakage Current	$GND \leq V_{IN} \leq V_{CC}$	-1		+1	$\mu A$
$I_{OZ}$	Output Leakage Current	$GND \leq V_{IN} \leq V_{CC}$ , Output Disabled	-1		+1	$\mu A$

#### Notes:

- $V_{IL}$  (min.) = -2.0V for pulse durations of less than 20 ns.
- $T_A$  is the "Instant-On" case temperature



## CY62256V

## Electrical Characteristics Over the Operating Range (continued)

Parameter	Description	Test Conditions	CY62256V25-100			Unit
			Min.	Typ. <sup>[2]</sup>	Max.	
$I_{CC}$	$V_{CC}$ Operating Supply Current	$V_{CC} = 2.7V, I_{OUT} = 0\text{ mA}, f = f_{MAX}$ $= 1/t_{RC}$	Com'l, Ind'l	9	15	mA
$I_{SB1}$	Automatic CE Power-down Current— TTL Inputs	$V_{CC} = 2.7V, CE \geq V_{IH},$ $V_{IN} \geq V_{IH}$ or $V_{IN} \leq V_{IL}, f = f_{MAX}$	Com'l, Ind'l	75	225	$\mu\text{A}$
$I_{SB2}$	Automatic CE Power-down Current — CMOS Inputs	$V_{CC} = 2.7V, CE \geq V_{CC} - 0.3V$ $V_{IN} \geq V_{CC} - 0.3V$ or $V_{IN} \leq 0.3V, f = 0$	Com'l	0.1	4	
			Ind'l		8	

Capacitance<sup>[5]</sup>

Parameter	Description	Test Conditions	Max.	Unit
$C_{IN}$	Input Capacitance	$T_A = 25^\circ\text{C}, f = 1\text{ MHz},$ $V_{CC} = 3.0V$	6	pF
$C_{OUT}$	Output Capacitance		8	pF

## AC Test Loads and Waveforms

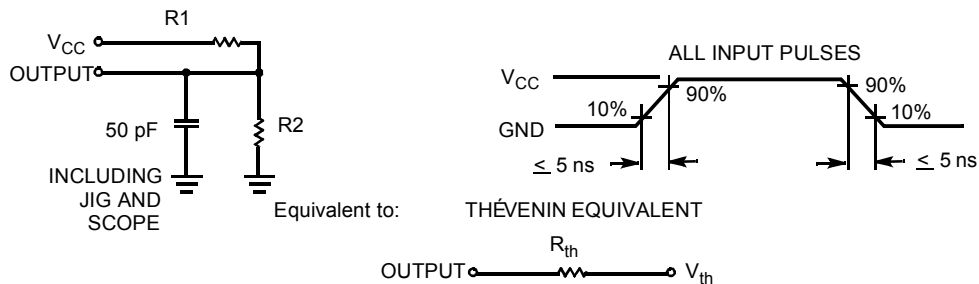

Parameter	3.3V	2.5V	Units
R1	1100	16600	Ohms
R2	1500	15400	Ohms
RTH	645	8000	Ohms
VTH	1.750	1.20	Volts

## Notes:

5. Tested initially and after any design or process changes that may affect these parameters.



### Data Retention Characteristics (Over the Operating Range)

Parameter	Description	Conditions <sup>[6]</sup>	Min.	Typ. <sup>[2]</sup>	Max.	Unit
$V_{DR}$	$V_{CC}$ for Data Retention		1.4			V
$I_{CCDR}$	Data Retention Current	$V_{CC} = 1.6V, CE \geq V_{CC} - 0.3V,$ $V_{IN} \geq V_{CC} - 0.3V$ or $V_{IN} \leq 0.3V$	Com'l	0.1	3	$\mu A$
			Ind'l		6	
			Auto		50	
$t_{CDR}^{[6]}$	Chip Deselect to Data Retention Time		0			ns
$t_R^{[6]}$	Operation Recovery Time		$t_{RC}$			ns

### Data Retention Waveform

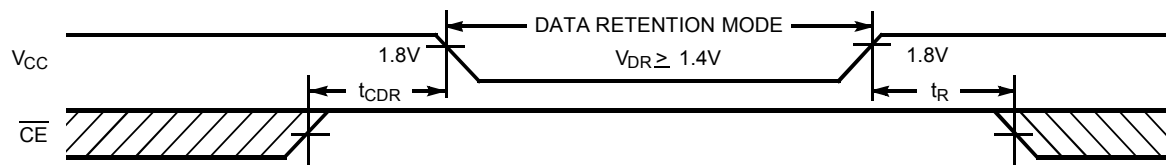

### Thermal Resistance

Parameter	Description	Test Conditions	SOIC	TSOPI	RTSOPI	Unit
$\Theta_{JA}$	Thermal Resistance (Junction to Ambient) <sup>[6]</sup>	Still Air, soldered on a 3 × 4.5 inch, four-layer printed circuit board	68.45	87.62	87.62	$^{\circ}C/W$
$\Theta_{JC}$	Thermal Resistance (Junction to Case) <sup>[5]</sup>		26.94	23.73	23.73	$^{\circ}C/W$

#### Notes:

6. No input may exceed  $V_{CC} + 0.3V$ .

Switching Characteristics Over the Operating Range<sup>[7]</sup>

Parameter	Description	CY62256V-70		CY62256V25-100		Unit
		Min.	Max.	Min.	Max.	
<b>Read Cycle</b>						
$t_{RC}$	Read Cycle Time	70		100		ns
$t_{AA}$	Address to Data Valid		70		100	ns
$t_{OHA}$	Data Hold from Address Change	10		10		ns
$t_{ACE}$	CE LOW to Data Valid		70		100	ns
$t_{DOE}$	OE LOW to Data Valid		35		75	ns
$t_{LZOE}$	OE LOW to Low-Z <sup>[8]</sup>	5		5		ns
$t_{HZOE}$	OE HIGH to High-Z <sup>[8, 9]</sup>		25		50	ns
$t_{LZCE}$	CE LOW to Low-Z <sup>[8]</sup>	10		10		ns
$t_{HZCE}$	CE HIGH to High-Z <sup>[8, 9]</sup>		25		50	ns
$t_{PU}$	CE LOW to Power-up	0		0		ns
$t_{PD}$	CE HIGH to Power-down		70		100	ns
<b>Write Cycle<sup>[10, 11]</sup></b>						
$t_{WC}$	Write Cycle Time	70		100		ns
$t_{SCE}$	CE LOW to Write End	60		90		ns
$t_{AW}$	Address Set-up to Write End	60		90		ns
$t_{HA}$	Address Hold from Write End	0		0		ns
$t_{SA}$	Address Set-up to Write Start	0		0		ns
$t_{PWE}$	WE Pulse Width	50		80		ns
$t_{SD}$	Data Set-up to Write End	30		60		ns
$t_{HD}$	Data Hold from Write End	0		0		ns
$t_{HZWE}$	WE LOW to High-Z <sup>[8, 9]</sup>		25		50	ns
$t_{LZWE}$	WE HIGH to Low-Z <sup>[8]</sup>	10		10		ns

**Notes:**

- Test conditions assume signal transition time of 5 ns or less timing reference levels of  $V_{CC}/2$ , input pulse levels of 0 to  $V_{CC}$ , and output loading of the specified  $I_{OL}/I_{OH}$  and 100-pF load capacitance.
- At any given temperature and voltage condition,  $t_{HZCE}$  is less than  $t_{LZCE}$ ,  $t_{HZOE}$  is less than  $t_{LZOE}$ , and  $t_{HZWE}$  is less than  $t_{LZWE}$  for any given device.
- $t_{HZOE}$ ,  $t_{HZCE}$ , and  $t_{HZWE}$  are specified with  $C_L = 5$  pF as in (b) of AC Test Loads. Transition is measured  $\pm 200$  mV from steady-state voltage.
- The internal write time of the memory is defined by the overlap of CE LOW and WE LOW. Both signals must be LOW to initiate a write and either signal can terminate a write by going HIGH. The data input set-up and hold timing should be referenced to the rising edge of the signal that terminates the write.
- The minimum write cycle time for write cycle #3 (WE controlled, OE LOW) is the sum of  $t_{HZWE}$  and  $t_{SD}$ .



Switching Waveforms

Read Cycle No. 1<sup>[12, 13]</sup>

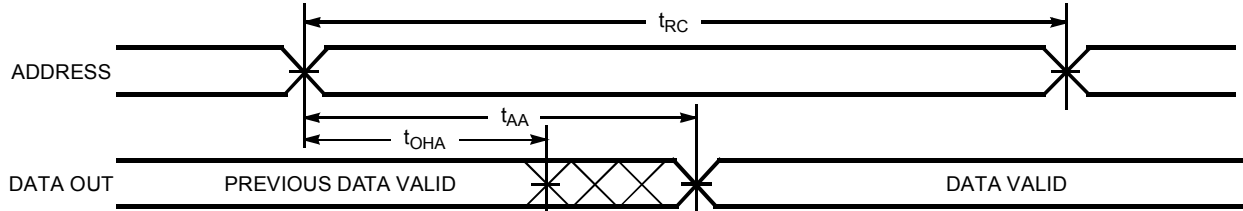

Read Cycle No. 2<sup>[13, 14]</sup>

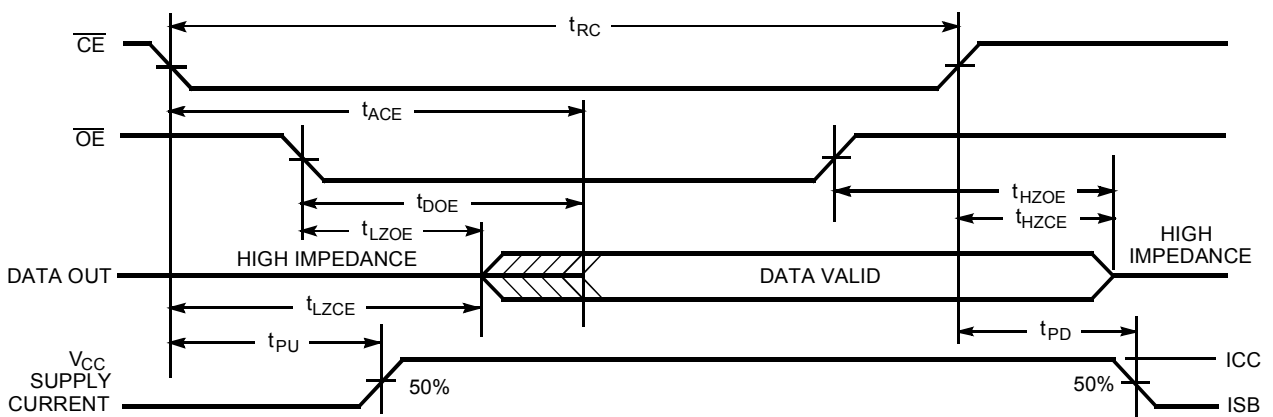

Write Cycle No. 1 (WE Controlled)<sup>[10, 15, 16]</sup>

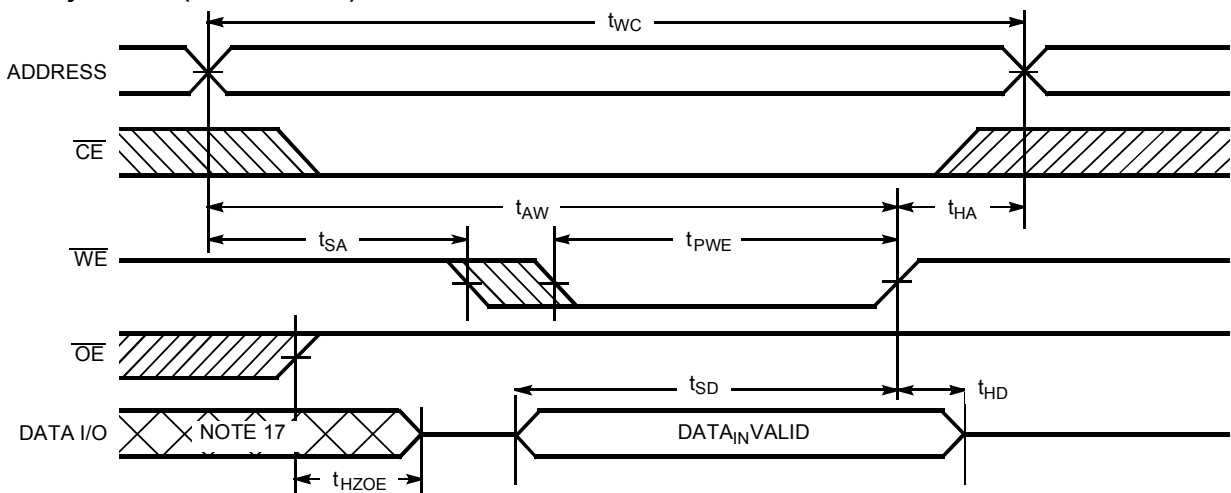

Notes:

- 12. Device is continuously selected.  $\overline{OE}, \overline{CE} = V_{IL}$ .
- 13. WE is HIGH for read cycle.

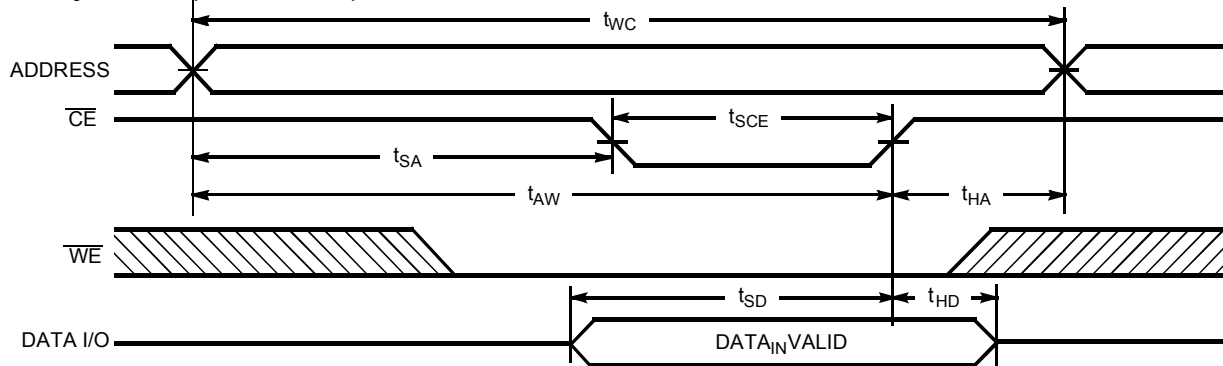
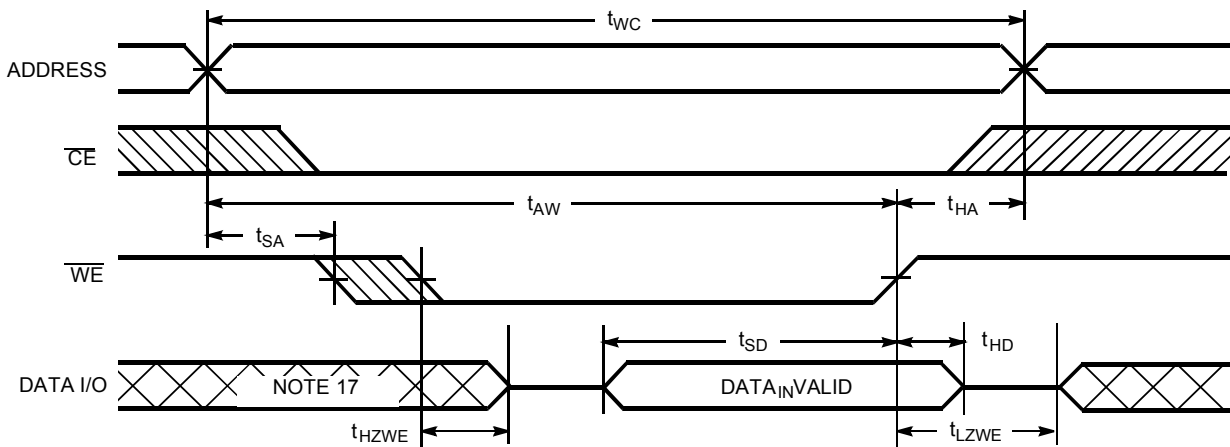

## Switching Waveforms (continued)

Write Cycle No. 2 ( $\overline{\text{CE}}$  Controlled)<sup>[10, 15, 16]</sup>Write Cycle No. 3 ( $\overline{\text{WE}}$  Controlled,  $\overline{\text{OE}}$  LOW)<sup>[11, 16]</sup>

## Notes:

14. Address valid prior to or coincident with  $\overline{\text{CE}}$  transition LOW.
15. Data I/O is high impedance if  $\text{OE} = V_{\text{IH}}$ .
16. If  $\overline{\text{CE}}$  goes HIGH simultaneously with  $\overline{\text{WE}}$  HIGH, the output remains in a high-impedance state.
17. During this period, the I/Os are in output state and input signals should not be applied.



Typical DC and AC Characteristics

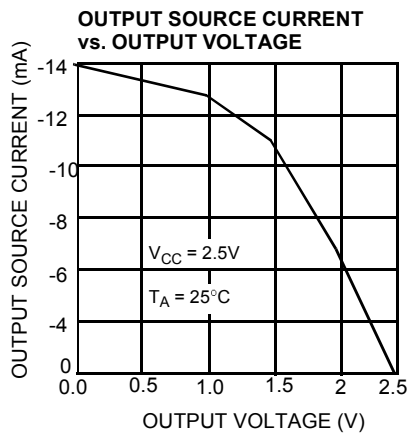
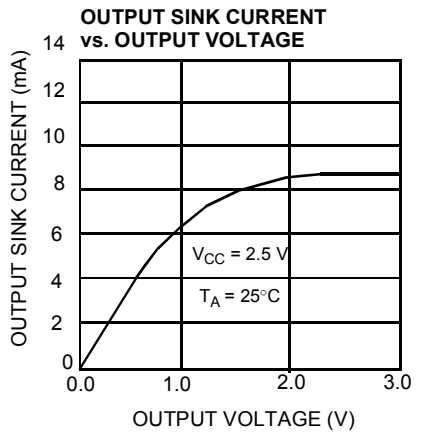
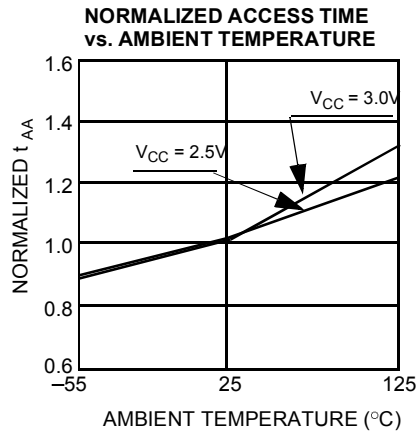
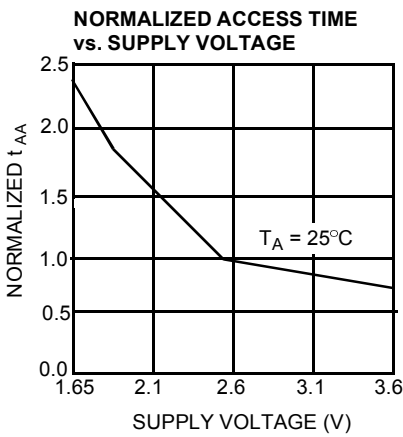
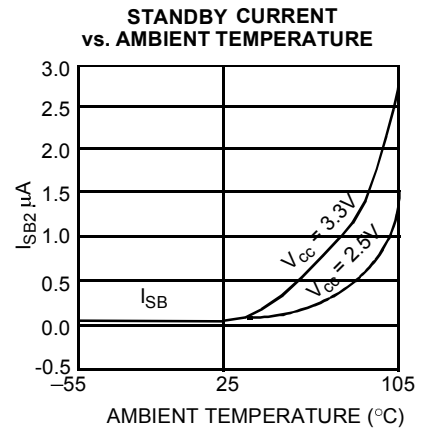
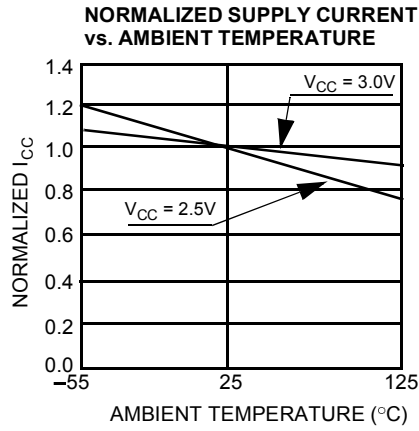
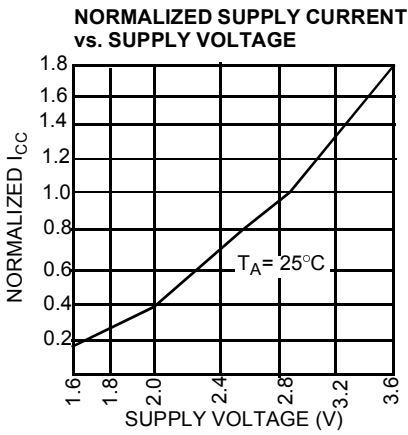



### Typical DC and AC Characteristics (continued)

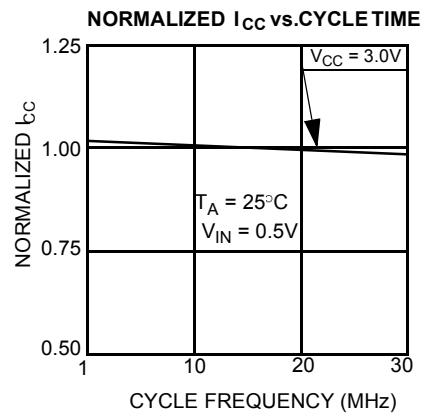
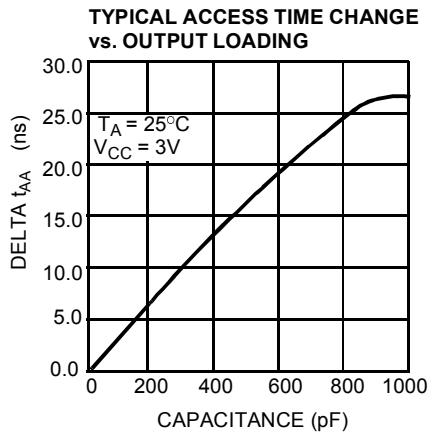

### Truth Table

$\overline{CE}$	$\overline{WE}$	$\overline{OE}$	Inputs/Outputs	Mode	Power
H	X	X	High-Z	Deselect/Power-down	Standby ( $I_{SB}$ )
L	H	L	Data Out	Read	Active ( $I_{CC}$ )
L	L	X	Data In	Write	Active ( $I_{CC}$ )
L	H	H	High-Z	Deselect, Output Disabled	Active ( $I_{CC}$ )

### Ordering Information

Speed (ns)	Ordering Code	Package Name	Package Type	Operating Range	
70	CY62256VLL-70SNC	SN28	28-lead (300-mil Narrow Body) Narrow SOIC	Commercial	
	CY62256VLL-70ZC	Z28	28-lead Thin Small Outline Package		
	CY62256VLL-70ZI				Industrial
	CY62256VLL-70SNI	SN28	28-lead (300-mil Narrow Body) Narrow SOIC		
	CY62256VLL-70ZRI	ZR28	28-lead Reverse Thin Small Outline Package	Automotive	
	CY62256VLL-70SNE	SN28	28-lead (300-mil Narrow Body) Narrow SOIC		
	CY62256VLL-70ZE	Z28	28-lead Thin Small Outline Package		
	CY62256VLL-70ZRE	ZR28	28-lead Reverse Thin Small Outline Package		
100	CY62256V25LL-100ZC	Z28	28-lead Thin Small Outline Package	Commercial	



**CY62256V**

**Package Diagrams**

**28-lead (300-mil) SNC (Narrow Body) SN28**

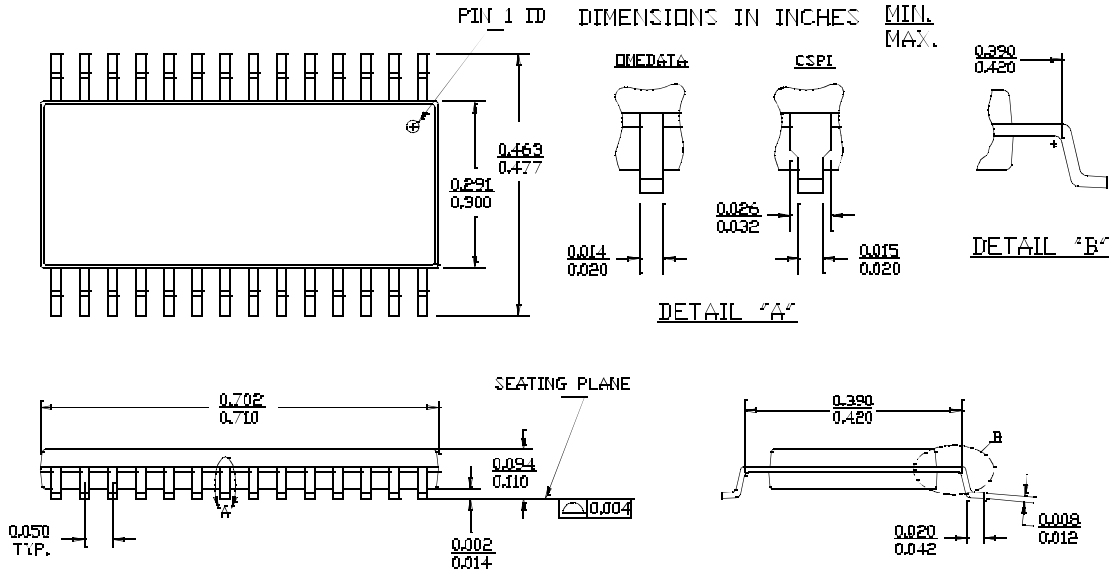

**28-lead Thin Small Outline Package Type 1 (8 × 13.4 mm) Z28**

NOTE: ORIENTATION I.D. MAY BE LOCATED EITHER AS SHOWN IN OPTION 1 OR OPTION 2

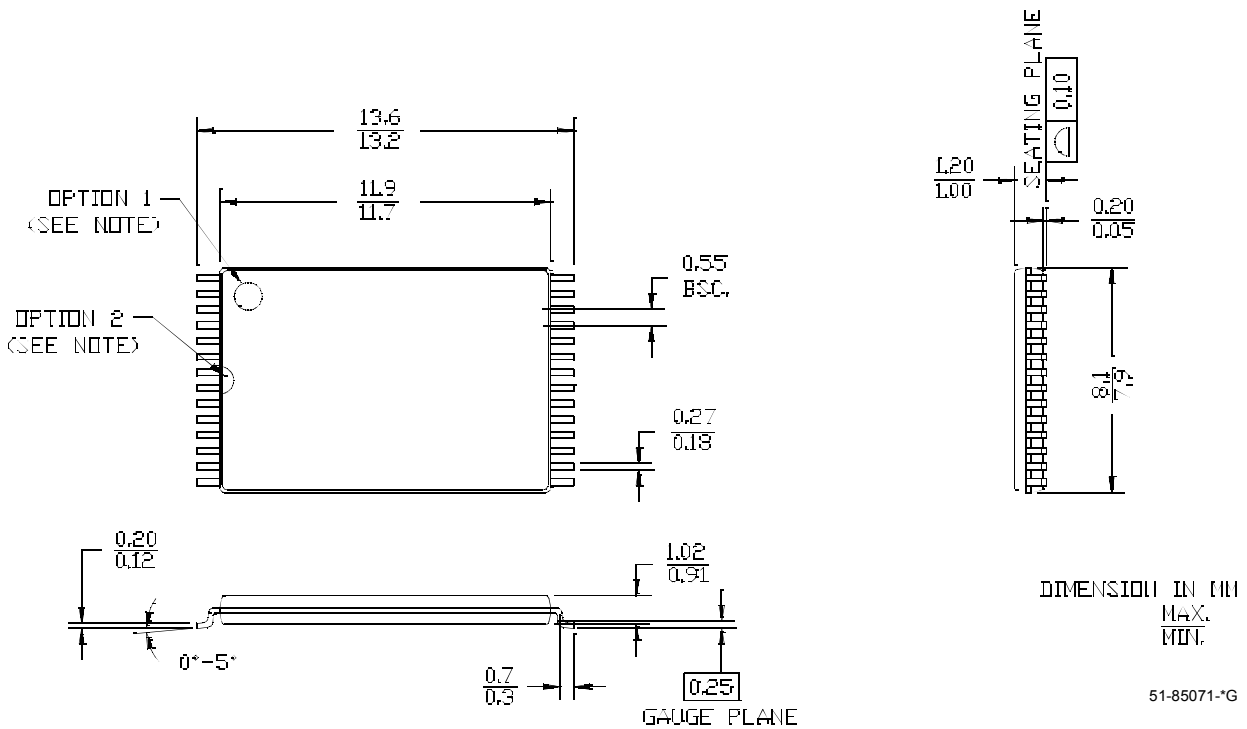



Package Diagrams (continued)

28-lead Reverse Type 1 Thin Small Outline Package (8 × 13.4 mm) ZR28

NOTE: ORIENTATION ID MAY BE LOCATED EITHER AS SHOWN IN OPTION 1 OR OPTION 2

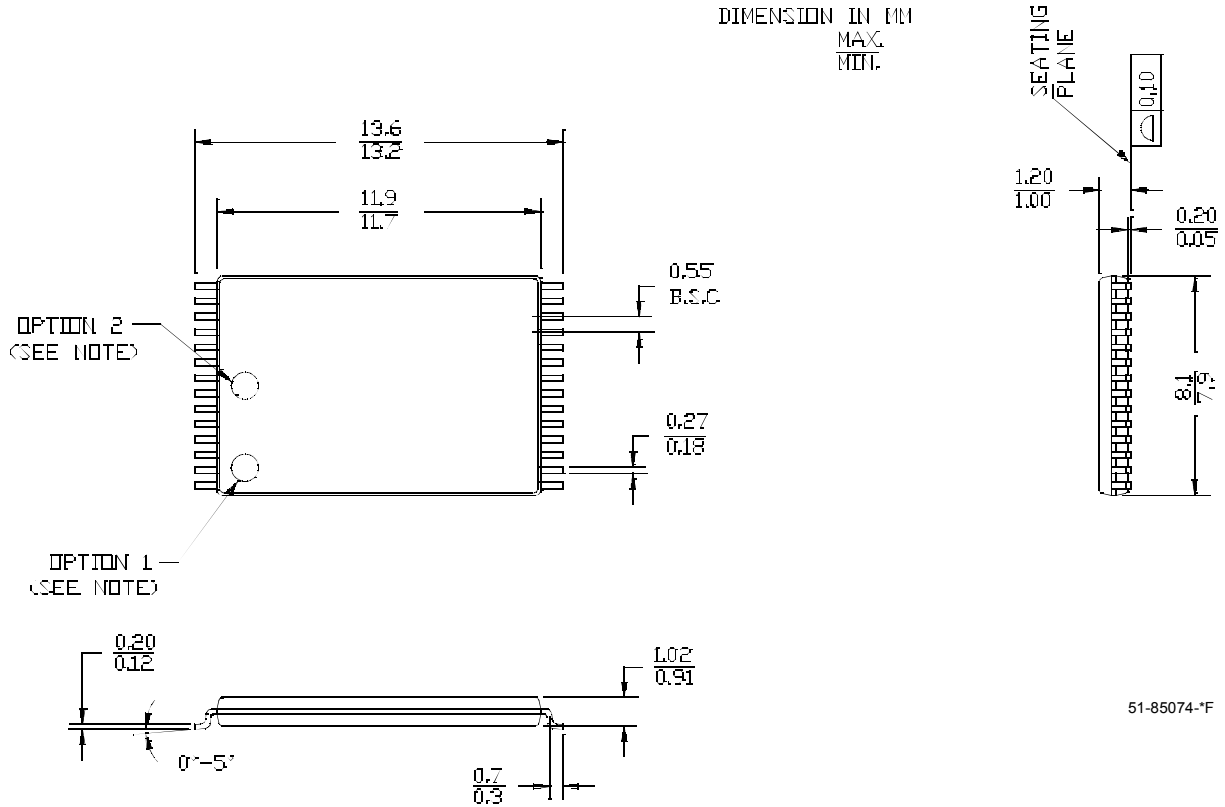

51-85074-\*F

All product and company names mentioned in this document are the trademarks of their respective holders.

**CY62256V**

<b>Document Title: CY62256V 256K (32K x 8) Static RAM</b>				
<b>Document Number: 38-05057</b>				
<b>REV.</b>	<b>ECN NO.</b>	<b>Issue Date</b>	<b>Orig. of Change</b>	<b>Description of Change</b>
**	107248	09/10/01	SZV	Changed from spec number: 38-00519 to 38-05057
*A	111445	11/01/01	MGN	Removed obsolete parts. Change to standard format
*B	115229	05/23/02	GBI	Changed SN package diagram
*C	116507	09/04/02	GBI	Added footnote 1 Clarified I <sub>CC</sub> spec for V <sub>CC(typ)</sub> = 2.5V
*D	239134	See ECN	AJU	Added Automotive product information