

## COP472-3 Liquid Crystal Display Controller

### General Description

The COP472-3 Liquid Crystal Display (LCD) Controller is a peripheral member of the COPS™ family, fabricated using CMOS technology. The COP472-3 drives a multiplexed liquid crystal display directly. Data is loaded serially and is held in internal latches. The COP472-3 contains an on-chip oscillator and generates all the multi-level waveforms for backplanes and segment outputs on a triplex display. One COP472-3 can drive 36 segments multiplexed as 3 x 12 (4½ digit display). Two COP472-3 devices can be used together to drive 72 segments (3 x 24) which could be an 8½ digit display.

### Features

- Direct interface to TRIPLEX LCD
- Low power dissipation (100 μW typ.)
- Low cost
- Compatible with all COPS processors
- Needs no refresh from processor
- On-chip oscillator and latches
- Expandable to longer displays
- Operates from display voltage
- MICROWIRE™ compatible serial I/O
- 20-pin Dual-In-Line package and 20-pin SO

### Block Diagram

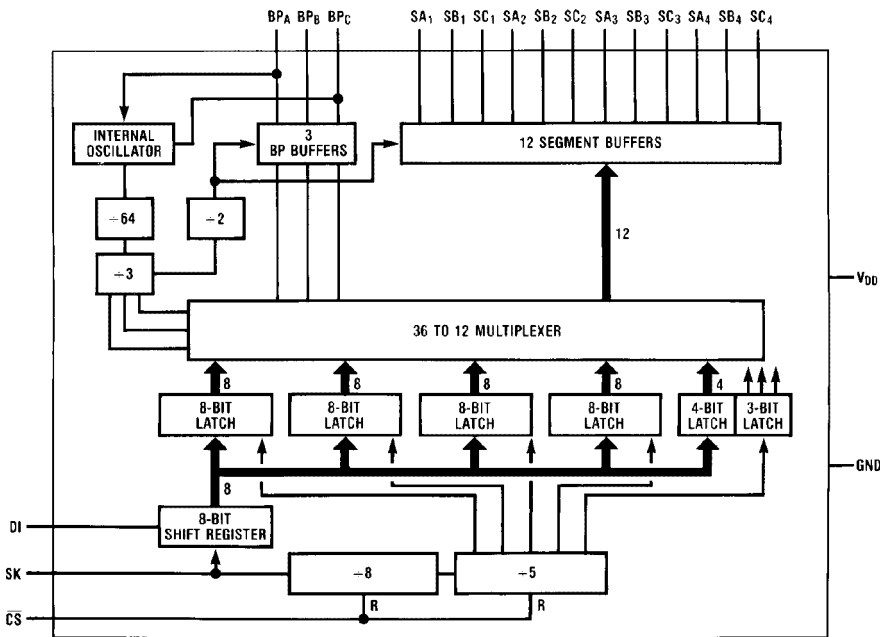

TL/DD/6932-1

COPS™ and MICROWIRE™ are trademarks of National Semiconductor Corporation.

## Absolute Maximum Ratings

Voltage at CS, DI, SK pins	-0.3V to +9.5V	Storage Temperature	-65°C to +150°C
Voltage at all other Pins	-0.3V to $V_{DD} + 0.3V$	Lead Temp. (Soldering, 10 Seconds)	300°C
Operating Temperature Range	0°C to 70°C		

## DC Electrical Characteristics

GND = 0V,  $V_{DD}$  = 3.0V to 5.5V,  $T_A$  = 0°C to 70°C (depends on display characteristics)

Parameter	Conditions	Min	Max	Units
Power Supply Voltage, $V_{DD}$		3.0	5.5	Volts
Power Supply Current, $I_{DD}$ (Note 1)	$V_{DD} = 5.5V$		250	$\mu A$
	$V_{DD} = 3V$		100	$\mu A$
Input Levels DI, SK, CS $V_{IL}$ $V_{IH}$			0.8	Volts
		$0.7 V_{DD}$	9.5	Volts
BPA (as Osc. in) $V_{IL}$ $V_{IH}$			0.6	Volts
		$V_{DD} - 0.6$	$V_{DD}$	Volts
Output Levels, BPC (as Osc. Out) $V_{OL}$ $V_{OH}$			0.4	Volts
		$V_{DD} - 0.4$	$V_{DD}$	Volts
Backplane Outputs (BPA, BPB, BPC) $V_{BPA, BPB, BPC}$ ON $V_{BPA, BPB, BPC}$ OFF	During BP+ Time	$V_{DD} - \Delta V$	$V_{DD}$	Volts
		$\frac{1}{3} V_{DD} - \Delta V$	$\frac{1}{3} V_{DD} + \Delta V$	Volts
$V_{BPA, BPB, BPC}$ ON $V_{BPA, BPB, BPC}$ OFF	During BP- Time	0	$\Delta V$	Volts
		$\frac{2}{3} V_{DD} - \Delta V$	$\frac{2}{3} V_{DD} + \Delta V$	Volts
Segment Outputs (SA <sub>1</sub> ~ SA <sub>4</sub> ) $V_{SEG}$ ON $V_{SEG}$ OFF	During BP+ Time	0	$\Delta V$	Volts
		$\frac{2}{3} V_{DD} - \Delta V$	$\frac{2}{3} V_{DD} + \Delta V$	Volts
$V_{SEG}$ ON $V_{SEG}$ OFF	During BP- Time	$V_{DD} - \Delta V$	$V_{DD}$	Volts
		$\frac{1}{3} V_{DD} - \Delta V$	$\frac{1}{3} V_{DD} + \Delta V$	Volts
Internal Oscillator Frequency		15	80	kHz
Frame Time (Int. Osc. $\div$ 192)		2.4	12.8	ms
Scan Frequency ( $1/T_{SCAN}$ )		39	208	Hz
SK Clock Frequency		4	250	kHz
SK Width		1.7		$\mu s$
DI Data Setup, $t_{SETUP}$ Data Hold, $t_{HOLD}$		1.0		$\mu s$
		100		ns
$\overline{CS}$ $t_{SETUP}$ $t_{HOLD}$		1.0		$\mu s$
		1.0		$\mu s$
Output Loading Capacitance			100	pF

**Note 1:** Power supply current is measured in stand-alone mode with all outputs open and all inputs at  $V_{DD}$ .

**Note 2:**  $\Delta V = 0.05V_{DD}$ .

## Absolute Maximum Ratings

If Military/Aerospace specified devices are required, please contact the National Semiconductor Sales Office/Distributors for availability and specifications.

Voltage at CS, DI, SK Pins	-0.3V to +9.5V
Voltage at All Other Pins	-0.3V to $V_{DD} + 0.3V$
Operating Temperature Range	-40°C to +85°C

Storage Temperature	-65°C to +150°C
Lead Temperature (Soldering, 10 seconds)	300°C

## DC Electrical Characteristics

$GND = 0V$ ,  $V_{DD} = 3.0V$  to  $5.5V$ ,  $T_A = -40°C$  to  $+85°C$  (depends on display characteristics)

Parameter	Conditions	Min	Max	Units
Power Supply Voltage, $V_{DD}$		3.0	5.5	Volts
Power Supply Current, $I_{DD}$ (Note 1)	$V_{DD} = 5.5V$		300	$\mu A$
	$V_{DD} = 3V$		120	$\mu A$
Input Levels DI, SK, CS $V_{IL}$ $V_{IH}$		0.7 $V_{DD}$	0.8 9.5	Volts Volts
BPA (as Osc. In) $V_{IL}$ $V_{IH}$		$V_{DD} - 0.6$	0.6 $V_{DD}$	Volts Volts
Output Levels, BPC (as Osc. Out) $V_{OL}$ $V_{OH}$		$V_{DD} - 0.4$	0.4 $V_{DD}$	Volts Volts
Backplane Outputs (BPA, BPB, BPC) $V_{BPA, BPB, BPC}$ ON $V_{BPA, BPB, BPC}$ OFF	During BP+ Time	$V_{DD} - \Delta V$ $\frac{1}{3} V_{DD} - \Delta V$	$V_{DD}$ $\frac{1}{3} V_{DD} + \Delta V$	Volts Volts
$V_{BPA, BPB, BPC}$ ON $V_{BPA, BPB, BPC}$ OFF	During BP- Time	0 $\frac{2}{3} V_{DD} - \Delta V$	$\Delta V$ $\frac{2}{3} V_{DD} + \Delta V$	Volts Volts
Segment Outputs ( $SA_1 \sim SA_4$ ) $V_{SEG}$ ON $V_{SEG}$ OFF	During BP+ Time	0 $\frac{2}{3} V_{DD} - \Delta V$	$\Delta V$ $\frac{2}{3} V_{DD} + \Delta V$	Volts Volts
$V_{SEG}$ ON $V_{SEG}$ OFF	During BP- Time	$V_{DD} - \Delta V$ $\frac{1}{3} V_{DD} - \Delta V$	$V_{DD}$ $\frac{1}{3} V_{DD} + \Delta V$	Volts Volts
Internal Oscillator Frequency		15	80	kHz
Frame Time (Int. Osc. $\div 192$ )		2.4	12.8	ms
Scan Frequency ( $1/T_{SCAN}$ )		39	208	Hz
SK Clock Frequency		4	250	kHz
SK Width		1.7		$\mu s$
DI Data Setup, $t_{SETUP}$ Data Hold, $t_{HOLD}$		1.0 100		$\mu s$ ns
$\overline{CS}$ $t_{SETUP}$ $t_{HOLD}$		1.0 1.0		$\mu s$ $\mu s$
Output Loading Capacitance			100	pF

**Note 1:** Power supply current is measured in stand-alone mode with all outputs open and all inputs at  $V_{DD}$ .

**Note 2:**  $\Delta V = 0.05 V_{DD}$ .

**Dual-In-Line Package**

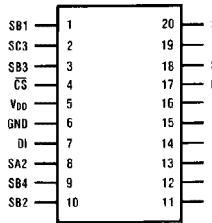

Top View

TL/DD/6932-2

Pin	Description
$\overline{CS}$	Chip select
$V_{DD}$	Power supply (display voltage)
GND	Ground
DI	Serial data input
SK	Serial clock input
$BP_A$	Display backplane A (or oscillator in)
$BP_B$	Display backplane B
$BP_C$	Display backplane C (or oscillator out)
SA1 ~ SC4	12 multiplexed outputs

Order Number COP472MW-3 or COP472N-3  
See NS Package Number M20A or N20A

**FIGURE 2. Connection Diagram**

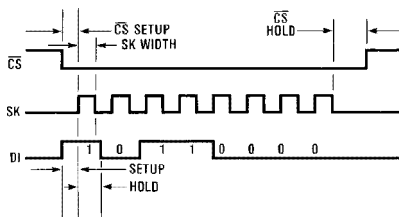

TL/DD/6932-3

**FIGURE 3. Serial Load Timing Diagram**

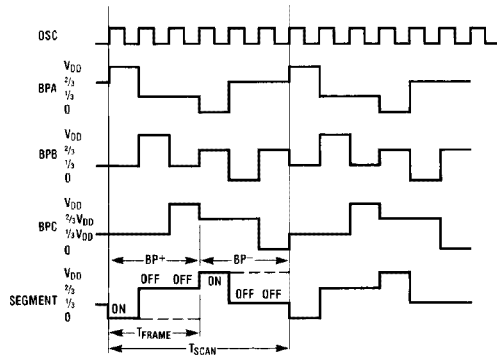

TL/DD/6932-4

**FIGURE 4. Backplane and Segment Waveforms**

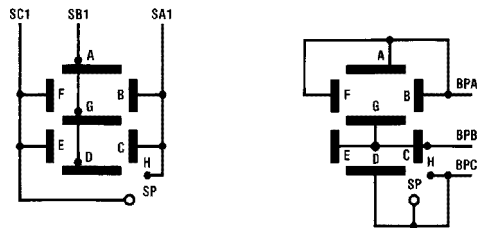

TL/DD/6932-5

**FIGURE 5. Typical Display Internal Connections  
Epson LD-370**

## Functional Description

The COP472-3 drives 36 bits of display information organized as twelve segments and three backplanes. The COP472-3 requires 40 information bits: 36 data and 4 control. The function of each control bit is described below. Display information format is a function of the LCD interconnections. A typical segment/backplane configuration is illustrated in *Figure 5*, with this configuration the COP472-3 will drive 4 digits of 9 segments.

To adapt the COP472-3 to any LCD display configuration, the segment/backplane multiplex scheme is illustrated in Table I.

Two or more COP472-3 chips can be cascaded to drive additional segments. There is no limit to the number of COP472-3's that can be used as long as the output loading capacitance does not exceed specification.

**TABLE I. COP472-3 Segment/Backplane Multiplex Scheme**

Bit Number	Segment, Backplane	Data to Numeric Display	
1	SA1, BPC	SH	
2	SB1, BPB	SG	
3	SC1, BPA	SF	
4	SC1, BPB	SE	
5	SB1, BPC	SD	Digit 1
6	SA1, BPB	SC	
7	SA1, BPA	SB	
8	SB1, BPA	SA	
9	SA2, BPC	SH	
10	SB2, BPB	SG	
11	SC2, BPA	SF	
12	SC2, BPB	SE	
13	SB2, BPC	SD	Digit 2
14	SA2, BPB	SC	
15	SA2, BPA	SB	
16	SB2, BPA	SA	
17	SA3, BPC	SH	
18	SB3, BPB	SG	
19	SC3, BPA	SF	
20	SC3, BPB	SE	
21	SB3, BPC	SD	Digit 3
22	SA3, BPB	SC	
23	SA3, BPA	SB	
24	SB3, BPA	SA	
25	SA4, BPC	SH	
26	SB4, BPB	SG	
27	SC4, BPA	SF	
28	SC4, BPB	SE	
29	SB4, BPC	SD	Digit 4
30	SA4, BPB	SC	
31	SA4, BPA	SB	
32	SB4, BPA	SA	
33	SC1, BPC	SPA	Digit 1
34	SC2, BPC	SP2	Digit 2
35	SC3, BPC	SP3	Digit 3
36	SC4, BPC	SP4	Digit 4
37	not used		
38	Q6		
39	Q7		
40	SYNC		

## SEGMENT DATA BITS

Data is loaded in serially, in sets of eight bits. Each set of segment data is in the following format:

SA	SB	SC	SD	SE	SF	SG	SH
----	----	----	----	----	----	----	----

Data is shifted into an eight bit shift register. The first bit of the data is for segment H, digit 1. The eighth bit is segment A, digit 1. A set of eight bits is shifted in and then loaded into the digit one latches. The second set of 8 bits is loaded into digit two latches. The third set into digit three latches, and the fourth set is loaded into digit four latches.

## CONTROL BITS

The fifth set of 8 data bits contains special segment data and control data in the following format:

SYNC	Q7	Q6	X	SP4	SP3	SP2	SP1
------	----	----	---	-----	-----	-----	-----

The first four bits shifted in contain the special character segment data. The fifth bit is not used. The sixth and seventh bits program the COP472-3 as a stand alone LCD driver or as a master or slave for cascading COP472-3's. BPC of the master is connected to BPA of each slave. The following table summarizes the function of bits six and seven:

Q7	Q6	Function	BPC Output	BPA Output
1	1	Slave	Backplane Output	Oscillator Input
0	1	Stand Alone	Backplane Output	Backplane Output
1	0	Not Used	Internal Osc. Output	Oscillator Input
0	0	Master	Internal Osc. Output	Backplane Output

The eighth bit is used to synchronize two COP472-3's to drive an 8½-digit display.

### LOADING SEQUENCE TO DRIVE A 4½-DIGIT DISPLAY

Steps:

1. Turn  $\overline{CE}$  low.
2. Clock in 8 bits of data for digit 1.
3. Clock in 8 bits of data for digit 2.
4. Clock in 8 bits of data for digit 3.
5. Clock in 8 bits of data for digit 4.
6. Clock in 8 bits of data for special segment and control function of BPC and BPA.

0	0	1	1	SP4	SP3	SP2	SP1
---	---	---	---	-----	-----	-----	-----

7. Turn  $\overline{CS}$  high.

**Note:**  $\overline{CS}$  may be turned high after any step. For example to load only 2 digits of data, do steps 1, 2, 3, and 7.

$\overline{CS}$  must make a high to low transition before loading data in order to reset internal counters.

### LOADING SEQUENCE TO DRIVE AN 8½-DIGIT DISPLAY

Two or more COP472-3's may be connected together to drive additional segments. An eight digit multiplexed display is shown in Figure 7. The following is the loading sequence to drive an eight digit display using two COP472-3's. The right chip is the master and the left the slave.

Steps:

1. Turn  $\overline{CS}$  low on both COP472-3's.
2. Shift in 32 bits of data for the slave's four digits.
3. Shift in 4 bits of special segment data: a zero and three ones.

1	1	1	0	SP4	SP3	SP2	SP1
---	---	---	---	-----	-----	-----	-----

This synchronizes both the chips and BPA is oscillator input. Both chips are now stopped.

4. Turn  $\overline{CS}$  high to both chips.
5. Turn  $\overline{CS}$  low to master COP472-3.
6. Shift in 32 bits of data for the master's 4 digits.
7. Shift in four bits of special segment data, a one and three zeros.

0	0	0	1	SP4	SP3	SP2	SP1
---	---	---	---	-----	-----	-----	-----

This sets the master COP472-3 to BPA as a normal backplane output and BPC as oscillator output. Now both the chips start and run off the same oscillator.

8. Turn  $\overline{CS}$  high.

The chips are now synchronized and driving 8 digits of display. To load new data simply load each chip separately in the normal manner, keeping the correct status bits to each COP472-3 (0110 or 0001).

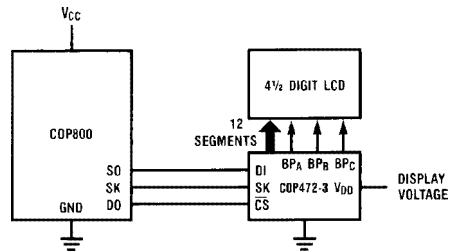

TL/DD/6932-6

FIGURE 6. System Diagram – 4½ Digit Display

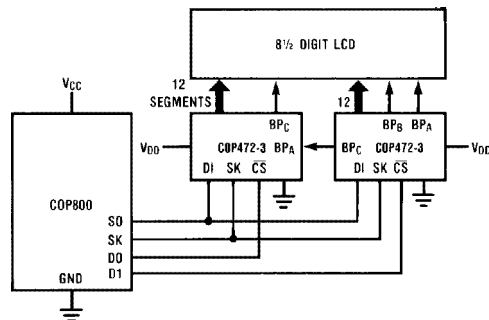

TL/DD/6932-7

FIGURE 7. System Diagram – 8½ Digit Display

**Physical Dimensions** inches (millimeters) unless otherwise noted

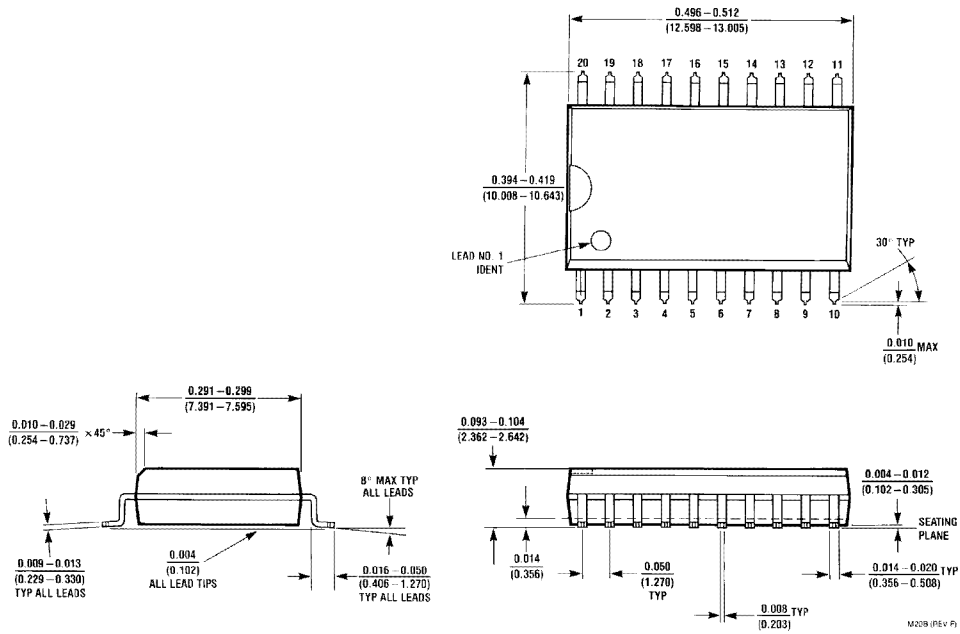

**20-Lead Molded DIP (M)**  
**Order Number COP472MW-3**  
**NS Package Number M20B**

M20B (REV P)

**Physical Dimensions** inches (millimeters) unless otherwise noted (Continued)

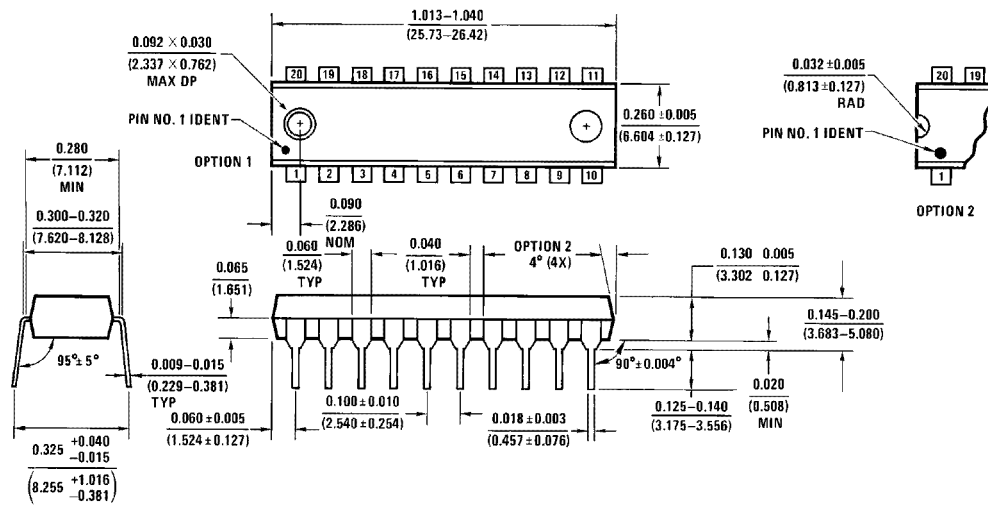

**20-Lead Molded DIP (N)**  
**Order Number COP472N-3**  
**NS Package Number N20A**

N20A (REV G)

**LIFE SUPPORT POLICY**

NATIONAL'S PRODUCTS ARE NOT AUTHORIZED FOR USE AS CRITICAL COMPONENTS IN LIFE SUPPORT DEVICES OR SYSTEMS WITHOUT THE EXPRESS WRITTEN APPROVAL OF THE PRESIDENT OF NATIONAL SEMICONDUCTOR CORPORATION. As used herein:

1. Life support devices or systems are devices or systems which, (a) are intended for surgical implant into the body, or (b) support or sustain life, and whose failure to perform, when properly used in accordance with instructions for use provided in the labeling, can be reasonably expected to result in a significant injury to the user.
2. A critical component is any component of a life support device or system whose failure to perform can be reasonably expected to cause the failure of the life support device or system, or to affect its safety or effectiveness.

 <p><b>National Semiconductor Corporation</b>          1111 West Bardin Road          Arlington, TX 76017          Tel: 1(800) 272-9959          Fax: 1(800) 737-7018</p> <p><a href="http://www.national.com">http://www.national.com</a></p>	<p><b>National Semiconductor Europe</b></p> <p>Fax: +49 (0) 180-530 85 86          Email: <a href="mailto:europe.support@nsc.com">europe.support@nsc.com</a>          Deutsch Tel: +49 (0) 180-530 85 85          English Tel: +49 (0) 180-532 78 32          Français Tel: +49 (0) 180-532 93 58          Italiano Tel: +49 (0) 180-534 16 80</p>	<p><b>National Semiconductor Hong Kong Ltd.</b>          13th Floor, Straight Block,          Ocean Centre, 5 Canton Rd.          Tsimshatsui, Kowloon          Hong Kong          Tel: (852) 2737-1600          Fax: (852) 2736-9960</p>	<p><b>National Semiconductor Japan Ltd.</b>          Tel: 81-043-299-2308          Fax: 81-043-299-2408</p>
---	--	---	---

National does not assume any responsibility for use of any circuitry described, no circuit patent licenses are implied and National reserves the right at any time without notice to change said circuitry and specifications.