

Features

PCI Support

- Single PCI PowerSpan (CA91L8260)
 - 64-bit/66MHz
 - 420 HPBGA
- Dual PCI PowerSpan (CA91L8200)
 - 32-bit/66MHz and 64-bit/66MHz
 - 480 HPBGA
- Integrated, non-transparent PCI-to-PCI bridge in the Dual PCI PowerSpan
- PCI arbiters on each PCI interface
- Universal PCI buffers — 3.3V/5V PCI signaling environment, 3.3V output buffers
- CompactPCI Hot Swap Friendly
- I₂O messaging unit
- *PCI 2.2 Specification* compliant

PowerSpan is the proven PowerPC-to-PCI Bus Switch.

Processor Support

- Direct connect interface for embedded PowerPC processors MPC8260, PowerPC 740, PowerPC 750, and PowerPC 603e
- 25 MHz to 100 MHz bus frequency
- Programmable endian conversion
- MPC8260 Configuration Slave support for power-up options
- Eight programmable memory maps to PCI from the processor
- Processor bus arbiter with support for three requesters

The PowerSpan Advantage

The Tundra PowerSpan is a PowerPC-to-PCI Bus Switch that bridges PCI to the PowerQUICC II (MPC8260) and the PowerPC 750, PowerPC 740, and PowerPC 603e processors. PowerSpan is available in either a single PCI or dual PCI variant. PowerSpan defines a new level of PCI bus switch flexibility.

The integrated, non-transparent PCI-to-PCI bridge in the Dual PCI PowerSpan provides a significant opportunity for designers to reduce component count and increase overall system performance.

The high level of performance and flexibility of PowerSpan is made possible through *Switched PCI* - unique to PowerSpan. Switched PCI uses a switching fabric to enable data streams to pass from port-to-port across the multi-ported PowerSpan without collision. This improves the burst performance and decreases latency on the PCI and processor busses — a key element of I/O processor performance.

Along with a revolutionary Switched PCI architecture, PowerSpan includes CompactPCI Hot Swap support and multiple bus arbiters. Other unique architectural aspects of PowerSpan also reduce transaction latencies across the bridge.

Figure 1: PowerSpan Functional Block Diagram

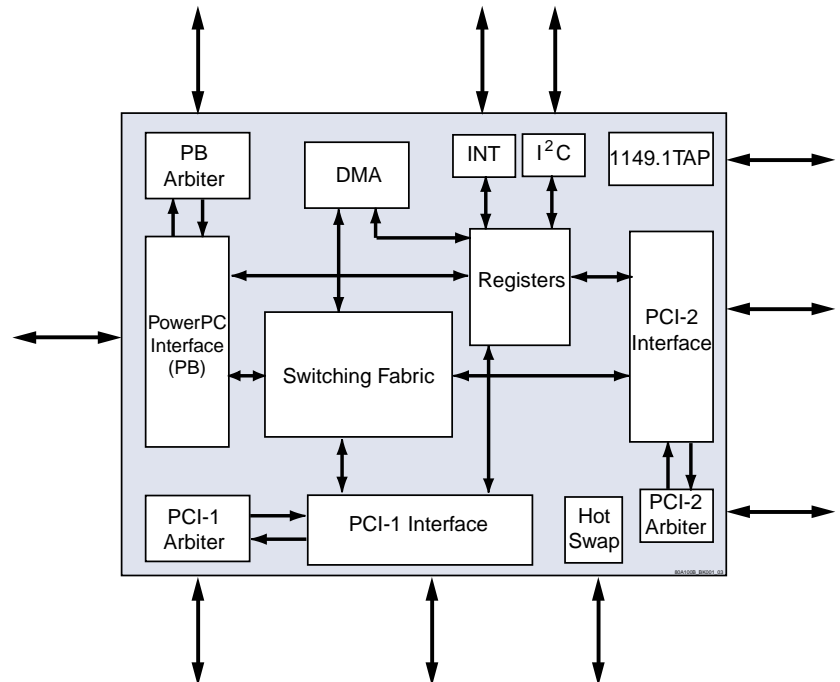

Benefits

- Integrated PCI bus and processor bus arbiters decrease individual component count on boards.
- Flexible PCI interfaces enable PowerSpan to meet many different application requirements.
- Integrated, non-transparent PCI-to-PCI bridge connects traffic between the two PCI interfaces. This decreases individual component count and simplifies conventional CompactPCI board architecture.

PowerSpan integrates many features—arbiters, PCI-to-PCI bridge— which decreases the number of components on a system board.

- Supports reads from multiple I/O devices in parallel, non-blocking streams which decreases bus latency.
- The Tundra PowerQUICC II and PowerPC architecture expertise is passed to customers with the Design Support Tools. Tundra offers a complete package of Design Support Tools including software, schematics, and evaluation board. For more information refer to www.tundra.com.
- Detailed design documentation including device manuals, performance information, and application notes.

Contact Information

Tundra Semiconductor Corporation
 603 March Road, Ottawa
 Ontario Canada, K2K 2M5
 (613) 592-0714 or 1-800-267-7231
 Fax: (613) 592-1320
www.tundra.com

Typical Applications

Tundra understands vendors' needs to increase performance throughout today's communications networks. From premise equipment to local carrier gear to high-end switches, designer's need to deliver ever-faster traffic through the same or smaller footprint at a reduced cost. Tundra System Interconnect helps in that effort by providing features and benefits across all areas of the network. PowerSpan helps designers working on infrastructure equipment in the following areas:

LAN/WAN	Remote/Local Access	Wireless
Exchange Carrier Switching Equipment	ADSL Concentrators	Third Generation (3G) Base Stations
Ethernet Switches	VoIP Gateways	
MPEG 2 Encoders	VPN Equipment	

PowerSpan is a very flexible device. The following diagram shows a typical PowerPC system architecture using PowerSpan, PowerQUICC II and dual PCI.

Figure 2: Typical PowerSpan Application

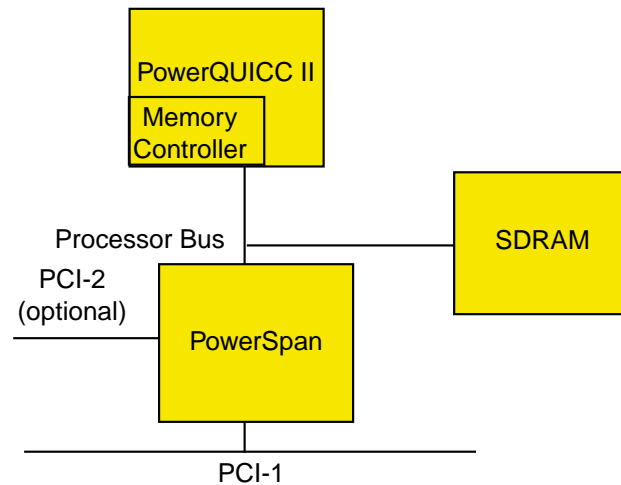

Product Ordering Information

Part Number	Description	Frequency	Voltage	Temperature	Package
CA91L8260-100CE	Single PCI	100MHz	3.3V	0° to 70°C	420 HPBGA
CA91L8260-100IE	Single PCI	100MHz	3.3V	-40° to 85°C	420 HPBGA
CA91L8200-100CE	Dual PCI	100MHz	3.3V	0° to 70°C	480 HPBGA
CA91L8200-100IE	Dual PCI	100MHz	3.3V	-40° to 85°C	480 HPBGA