

## BZX84C 3V3 - BZX84C 33 Series Zeners

Tolerance: C = 5%

### Absolute Maximum Ratings\*

TA = 25°C unless otherwise noted

Parameter	Value	Units
Storage Temperature Range	-55 to +150	°C
Maximum Junction Operating Temperature	+ 150	°C
Total Device Dissipation	350	mW
Derate above 25°C	1.8	mW/°C
Repetitive Peak Forward Current (I <sub>FRM</sub> )	250	mA
Repetitive Peak Working Current (I <sub>ZRM</sub> )	250	mA

\*These ratings are limiting values above which the serviceability of the diode may be impaired.

**NOTES:**

- 1) These ratings are based on a maximum junction temperature of 150 degrees C.
- 2) These are steady state limits. The factory should be consulted on applications involving pulsed or low duty cycle operations.

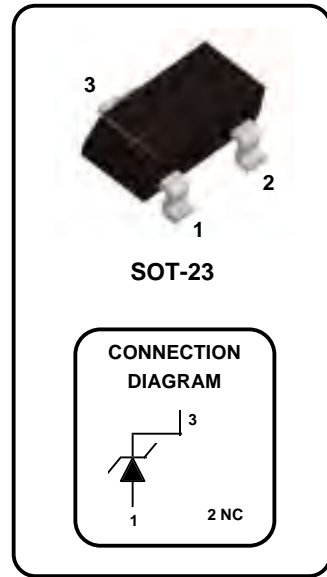

### Electrical Characteristics

TA = 25°C unless otherwise noted

Device	Mark	I <sub>ZT</sub> = 5.0 mA			I <sub>ZT</sub> = 1.0 mA			I <sub>ZT</sub> = 20 mA		
		V <sub>Z</sub> (V)		Z <sub>Z</sub> (Ω)	V <sub>Z</sub> (V)		Z <sub>Z</sub> (Ω)	V <sub>Z</sub> (V)		Z <sub>Z</sub> (Ω)
		MIN	MAX	(Ω)	MIN	MAX	(Ω)	MIN	MAX	(Ω)
BZX84C 3V3	Z14	3.1	3.5	95	2.3	2.9	600	3.6	4.2	40
BZX84C 3V6	Z15	3.4	3.8	90	2.7	3.3	600	3.9	4.5	40
BZX84C 3V9	Z16	3.7	4.1	90	2.9	3.5	600	4.1	4.7	30
BZX84C 4V3	Z17	4.0	4.6	90	3.3	4.0	600	4.4	5.1	30
<b>BZX84C 4V7</b>	Z1	4.4	5.0	80	3.7	4.7	500	4.5	5.4	15
<b>BZX84C 5V1</b>	Z2	4.8	5.4	60	4.2	5.3	480	5.0	5.9	15
<b>BZX84C 5V6</b>	Z3	5.2	6.0	40	4.8	6.0	400	5.2	6.3	10
<b>BZX84C 6V2</b>	Z4	5.8	6.6	10	5.6	6.6	150	5.8	6.8	6
<b>BZX84C 6V8</b>	Z5	6.4	7.2	15	6.3	7.2	80	6.4	7.4	6
BZX84C 7V5	Z6	7.0	7.9	15	6.9	7.9	80	7.0	8.0	6
<b>BZX84C 8V2</b>	Z7	7.7	8.7	15	7.6	8.7	80	7.7	8.8	6
<b>BZX84C 9V1</b>	Z8	8.5	9.6	15	8.4	9.6	100	8.5	9.7	8
<b>BZX84C 10</b>	Z9	9.4	10.6	20	9.3	10.6	150	9.4	10.7	10
BZX84C 11	Y1	10.4	11.6	20	10.2	11.6	150	10.4	11.8	10
<b>BZX84C 12</b>	Y2	11.4	12.7	25	11.2	12.7	150	11.4	12.9	10
BZX84C 13	Y3	12.4	14.1	30	12.3	14.0	170	12.5	14.2	15
<b>BZX84C 15</b>	Y4	13.8	15.6	30	13.7	15.5	200	13.9	15.7	20
BZX84C 16	Y5	15.3	17.1	40	15.2	17	200	15.4	17.2	20
BZX84C 18	Y6	16.8	19.1	45	16.7	19	225	16.9	19.2	20
BZX84C 20	Y7	18.8	21.2	55	18.7	21.1	225	18.9	21.4	20
BZX84C 22	Y8	20.8	23.3	55	20.7	23.2	250	20.9	23.4	25
BZX84C 24	Y9	22.8	25.6	70	22.7	25.5	250	22.9	25.7	25

**NOTE:** National preferred devices in **BOLD**

## BZX84C Series Zeners

(continued)

### Electrical Characteristics (continued)

TA = 25°C unless otherwise noted

Device	Mark	I <sub>ZT</sub> = 2.0 mA		I <sub>ZT</sub> = 100 μA*		I <sub>ZT</sub> = 10 mA				
		V <sub>Z</sub> (V)		Z <sub>Z</sub> (Ω)		V <sub>Z</sub> (V)		Z <sub>Z</sub> (Ω)		
		MIN	MAX	MIN	MAX	MIN	MAX			
BZX84C 27	Y10	25.1	28.9	80	25	28.9	300	25.2	29.3	45
<b>BZX84C 30</b>	Y11	28	32	80	27.8	32	300	28.1	32.4	50
BZX84C 33	Y12	31	35	80	30.8	35	325	31.1	35.4	55

V<sub>F</sub> Forward Voltage = 0.9 V Maximum @ I<sub>F</sub> = 10 mA for all BZX 84 series

\*Capacitance @ V<sub>R</sub> = 0.0 volts; Frequency = 1.0 megahertz.

Device	V <sub>R</sub> (V)	I <sub>R</sub> (μA)	CAP* (pF)	D <sub>VZ</sub> / D <sub>t</sub> @ 5.0 mA (mV/k)	
				MIN	MAX
BZX84C 3V3	1.0	5.0	450	- 3.5	0.0
BZX84C 3V6	1.0	5.0	450	- 3.5	0.0
BZX84C 3V9	1.0	5.0	450	- 3.5	0.0
BZX84C 4V3	1.0	5.0	450	- 3.5	0.0
BZX84C 4V7	2.0	3	260	- 3.5	+ 0.2
BZX84C 5V1	2.0	2	225	- 2.7	+ 1.2
BZX84C 5V6	2.0	1	200	- 2.0	+ 2.5
BZX84C 6V2	4.0	3	185	+ 0.4	+ 3.7
BZX84C 6V8	4.0	2	155	+ 1.2	+ 4.5
BZX84C 7V5	5.0	1	140	+ 2.5	+ 5.3
BZX84C 8V2	5.0	0.7	135	+ 3.2	+ 6.2
BZX84C 9V1	6.0	0.5	130	+ 3.8	+ 7.0
BZX84C 10	7.0	0.2	130	+ 4.5	+ 8.0
BZX84C 11	8.0	0.1	130	+ 5.4	+ 9.0
BZX84C 12	8.0	0.1	130	+ 6.0	+ 10
BZX84C 13	8.0	0.1	120	+ 7.0	+ 11
BZX84C 15	10.5	0.05	110	+ 9.2	+ 13
BZX84C 16	11.2	0.05	105	+ 10.4	+ 14
BZX84C 18	12.6	0.05	100	+ 12.4	+ 16
BZX84C 20	14	0.05	85	+ 14.4	+ 18
BZX84C 22	15.4	0.05	85	+ 16.4	+ 20
BZX84C 24	16.8	0.05	80	+ 18.4	+ 22

Device	V <sub>R</sub> (V)	I <sub>R</sub> (μA)	CAP* (pF)	D <sub>VZ</sub> / D <sub>t</sub> @ 2.0 mA (mV/k)	
				MIN	MAX
BZX84C 27	18.9	0.05	70	21.4	25.3
BZX84C 30	21	0.05	70	24.4	29.4
BZX84C 33	23.1	0.05	70	27.4	33.4

BZX84C 4V7 - BZX84C 33 Series

# SOT-23 Tape and Reel Data and Package Dimensions



**SOT-23 Packaging Configuration: Figure 10**

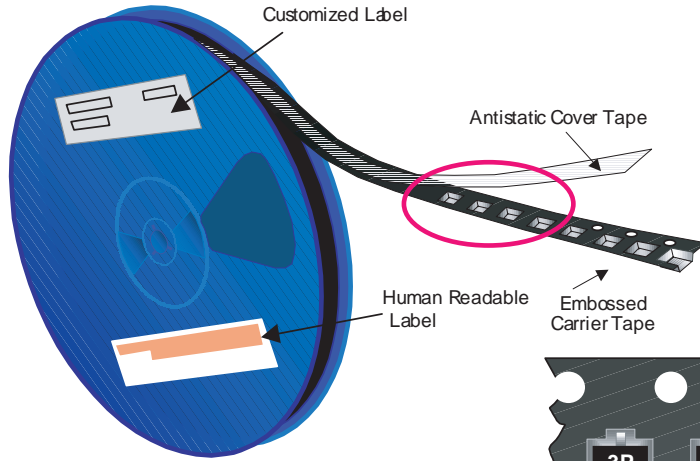

**Packaging Description:**

SOT-23 parts are shipped in tape. The carrier tape is made from a dissipative (carbon filled) polycarbonate resin. The cover tape is a multilayer film (Heat Activated Adhesive in nature) primarily composed of polyester film, adhesive layer, sealant, and anti-static sprayed agent. These reeled parts in standard option are shipped with 3,000 units per 7" or 177mm diameter reel. The reels are dark blue in color and is made of polystyrene plastic (anti-static coated). Other option comes in 10,000 units per 13" or 330mm diameter reel. This and some other options are described in the Packaging Information table.

These full reels are individually labeled and placed inside a standard intermediate made of recyclable corrugated brown paper with a Fairchild logo printing. One pizza box contains eight reels maximum. And these intermediate boxes are placed inside a labeled shipping box which comes in different sizes depending on the number of parts shipped.

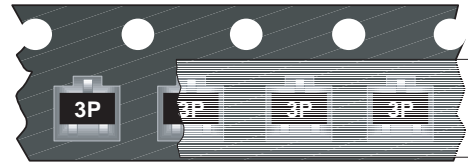

SOT-23 Packaging Information		
Packaging Option	Standard (no flow code)	D87Z
Packaging type	TNR	TNR
Qty per Reel/Tube/Bag	3,000	10,000
Reel Size	7" Dia	13"
Box Dimension (mm)	187x107x183	343x343x64
Max qty per Box	24,000	30,000
Weight per unit (gm)	0.0082	0.0082
Weight per Reel (kg)	0.1175	0.4006
Note/Comments		

**SOT-23 Unit Orientation**

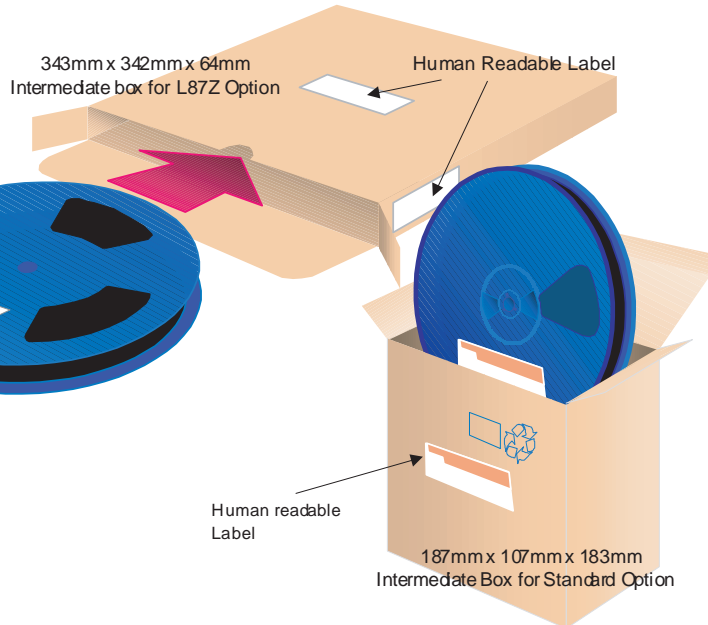

Human Readable Label sample



**SOT-23 Tape Leader and Trailer Configuration: Figure 20**

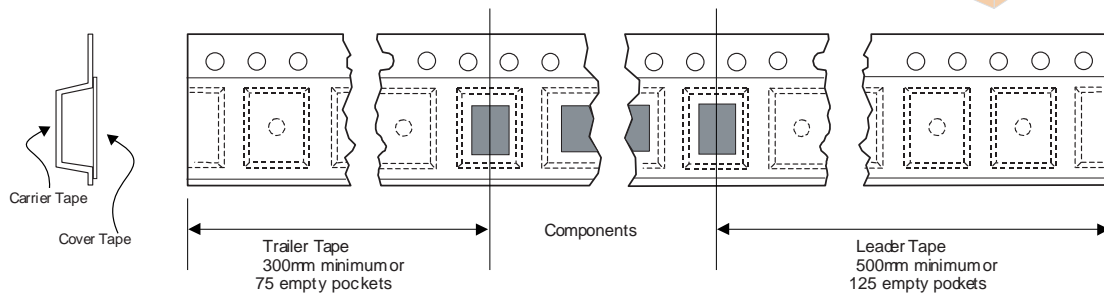

# SOT-23 Tape and Reel Data and Package Dimensions, continued

## SOT-23 Embossed Carrier Tape Configuration: Figure 3.0

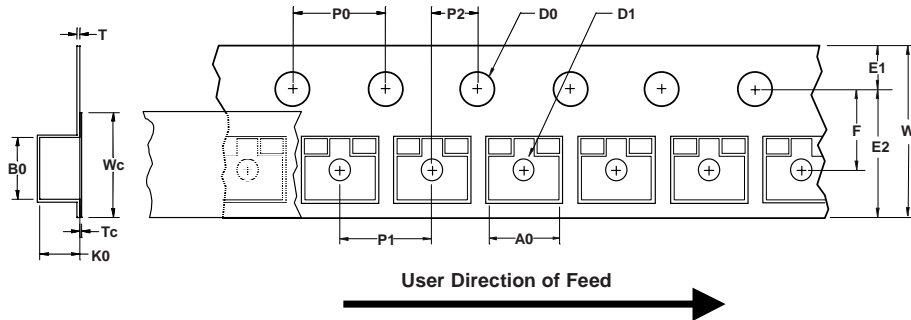

Dimensions are in millimeter														
Pkg type	A0	B0	W	D0	D1	E1	E2	F	P1	P0	K0	T	Wc	Tc
SOT-23 (8mm)	3.15 +/-0.10	2.77 +/-0.10	8.0 +/-0.3	1.55 +/-0.05	1.125 +/-0.125	1.75 +/-0.10	6.25 min	3.50 +/-0.05	4.0 +/-0.1	4.0 +/-0.1	1.30 +/-0.10	0.228 +/-0.013	5.2 +/-0.3	0.06 +/-0.02

Notes: A0, B0, and K0 dimensions are determined with respect to the EIA/Jedec RS-481 rotational and lateral movement requirements (see sketches A, B, and C).

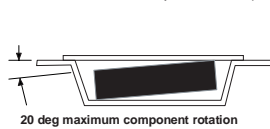

Sketch A (Side or Front Sectional View)  
Component Rotation

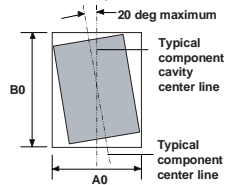

Sketch B (Top View)  
Component Rotation

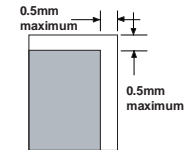

Sketch C (Top View)  
Component lateral movement

## SOT-23 Reel Configuration: Figure 4.0

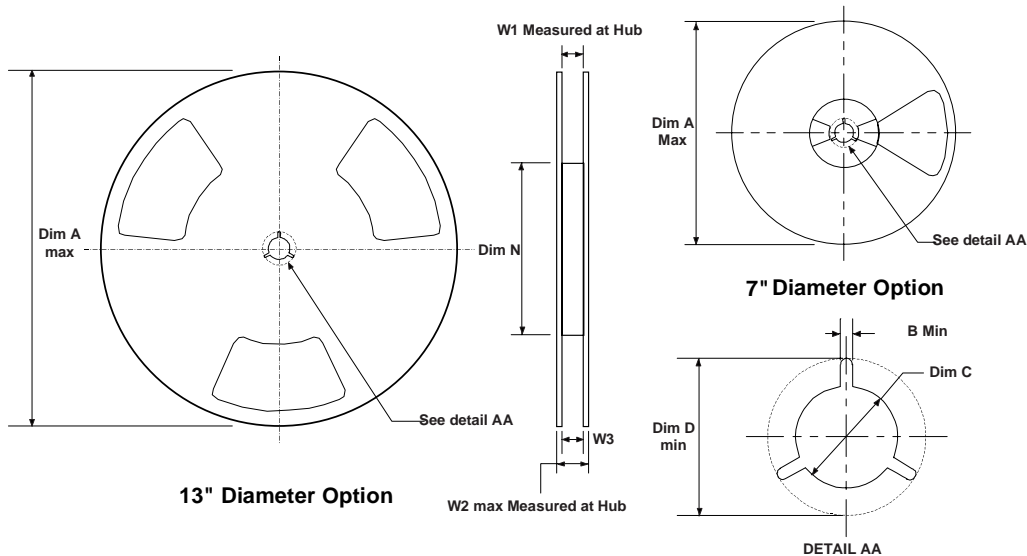

Dimensions are in inches and millimeters									
Tape Size	Reel Option	Dim A	Dim B	Dim C	Dim D	Dim N	Dim W1	Dim W2	Dim W3 (LSL-USL)
8mm	7" Dia	7.00 177.8	0.059 1.5	512 +0.020/-0.008 13 +0.5/-0.2	0.795 20.2	2.165 55	0.331 +0.059/-0.000 8.4 +1.5/0	0.567 14.4	0.311 - 0.429 7.9 - 10.9
8mm	13" Dia	13.00 330	0.059 1.5	512 +0.020/-0.008 13 +0.5/-0.2	0.795 20.2	4.00 100	0.331 +0.059/-0.000 8.4 +1.5/0	0.567 14.4	0.311 - 0.429 7.9 - 10.9

**SOT-23 Tape and Reel Data and Package Dimensions, continued**

**SOT-23 (FS PKG Code 49)**

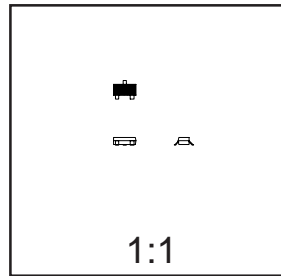
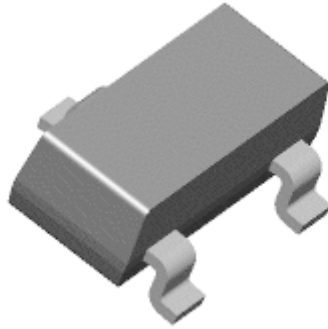

Scale 1:1 on letter size paper

Dimensions shown below are in:  
inches [millimeters]

Part Weight per unit (gram): 0.0082

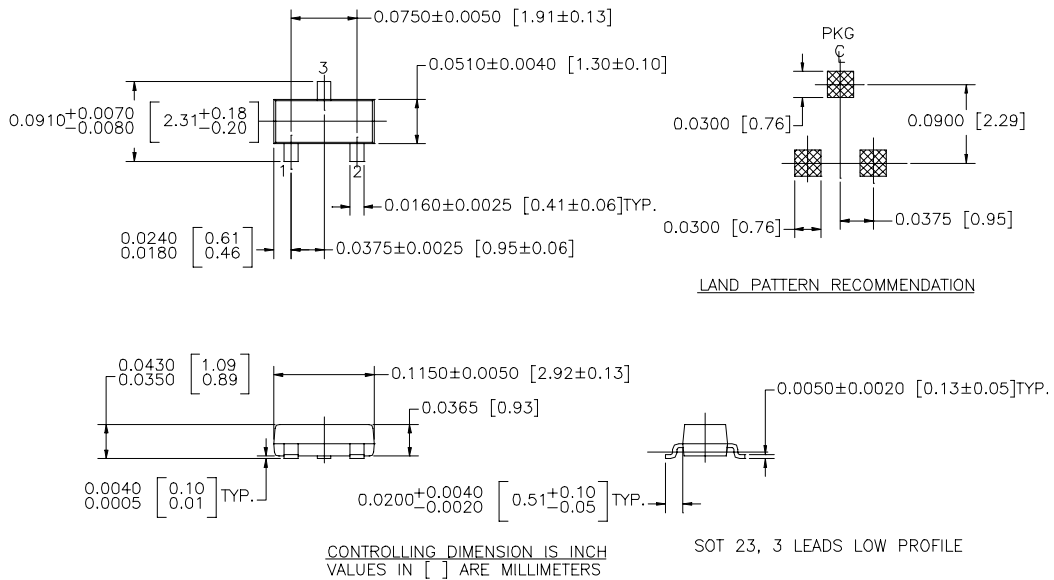

NOTE : UNLESS OTHERWISE SPECIFIED

1. STANDARD LEAD FINISH 150 MICROINCHES / 3.81 MICROMETERS  
MINIMUM TIN / LEAD (SOLDER) ON ALLOY 42
2. REFERENCE JEDEC REGISTRATION TO-236, VARIATION AB, ISSUE G, DATED JUL 1993

## TRADEMARKS

The following are registered and unregistered trademarks Fairchild Semiconductor owns or is authorized to use and is not intended to be an exhaustive list of all such trademarks.

ACEx™	HiSeC™	SuperSOT™-8
Bottomless™	ISOPLANAR™	SyncFET™
CoolFET™	MICROWIRE™	TinyLogic™
CROSSVOLT™	POP™	UHC™
E <sup>2</sup> CMOS™	PowerTrench®	VCX™
FACT™	QFET™	
FACT Quiet Series™	QS™	
FAST®	Quiet Series™	
FASTr™	SuperSOT™-3	
GTO™	SuperSOT™-6	

## DISCLAIMER

FAIRCHILD SEMICONDUCTOR RESERVES THE RIGHT TO MAKE CHANGES WITHOUT FURTHER NOTICE TO ANY PRODUCTS HEREIN TO IMPROVE RELIABILITY, FUNCTION OR DESIGN. FAIRCHILD DOES NOT ASSUME ANY LIABILITY ARISING OUT OF THE APPLICATION OR USE OF ANY PRODUCT OR CIRCUIT DESCRIBED HEREIN; NEITHER DOES IT CONVEY ANY LICENSE UNDER ITS PATENT RIGHTS, NOR THE RIGHTS OF OTHERS.

## LIFE SUPPORT POLICY

FAIRCHILD'S PRODUCTS ARE NOT AUTHORIZED FOR USE AS CRITICAL COMPONENTS IN LIFE SUPPORT DEVICES OR SYSTEMS WITHOUT THE EXPRESS WRITTEN APPROVAL OF FAIRCHILD SEMICONDUCTOR CORPORATION. As used herein:

1. Life support devices or systems are devices or systems which, (a) are intended for surgical implant into the body, or (b) support or sustain life, or (c) whose failure to perform when properly used in accordance with instructions for use provided in the labeling, can be reasonably expected to result in significant injury to the user.
2. A critical component is any component of a life support device or system whose failure to perform can be reasonably expected to cause the failure of the life support device or system, or to affect its safety or effectiveness.

## PRODUCT STATUS DEFINITIONS

### Definition of Terms

Datasheet Identification	Product Status	Definition
Advance Information	Formative or In Design	This datasheet contains the design specifications for product development. Specifications may change in any manner without notice.
Preliminary	First Production	This datasheet contains preliminary data, and supplementary data will be published at a later date. Fairchild Semiconductor reserves the right to make changes at any time without notice in order to improve design.
No Identification Needed	Full Production	This datasheet contains final specifications. Fairchild Semiconductor reserves the right to make changes at any time without notice in order to improve design.
Obsolete	Not In Production	This datasheet contains specifications on a product that has been discontinued by Fairchild semiconductor. The datasheet is printed for reference information only.