

8-channel analog multiplexer / demultiplexer

BU4051BC / BU4051BCF / BU4051BCFV

The BU4051BC, BU4051BCF and BU4051BCFV are analog multiplexers / demultiplexers which use three-input digital signals for control via an 8-channel analog switch. These products feature high on / off output voltage ratio and low crosstalk between analog switches.

●Block diagram

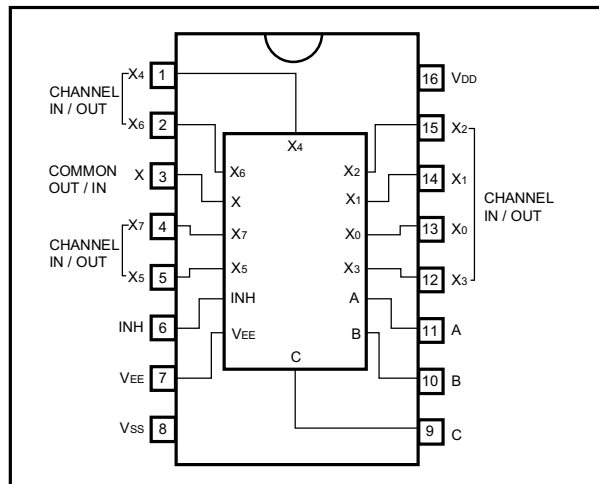

●Logic circuit diagram

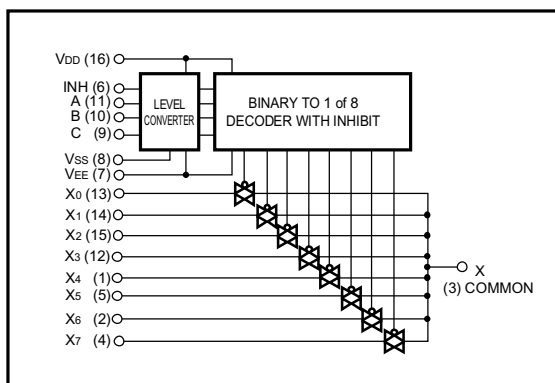

●Truth table

INH	A	B	C	ON SWITCH
L	L	L	L	X ₀
L	H	L	L	X ₁
L	L	H	L	X ₂
L	H	H	L	X ₃
L	L	L	H	X ₄
L	H	L	H	X ₅
L	L	H	H	X ₆
L	H	H	H	X ₇
H	X	X	X	NONE

X: Irrelevant

Standard ICs

BU4051BC / BU4051BCF / BU4051BCFV

● Absolute maximum ratings (Ta = 25°C)

Parameter	Symbol	Limits	Unit
Power supply voltage 1	V _{DD}	- 0.5 ~ + 20	V
Power supply voltage 2	V _{DD} -V _{EE}	- 0.5 ~ + 20	V
Power dissipation	P _d	1000 (DIP), 500 (SOP), 400 (SSOP)	mW
Operating temperature	T _{opr}	- 40 ~ + 85	°C
Storage temperature	T _{stg}	- 55 ~ + 150	°C
Input voltage	V _{IN}	- 0.5 ~ V _{DD} + 0.5	V

● Electrical characteristics

DC characteristics (unless otherwise noted, Ta = 25°C, V_{EE} = V_{SS} = 0V)

Parameter	Symbol	Min.	Typ.	Max.	Unit	Conditions	
						V _{DD} (V)	
Input high-level voltage	V _{IH}	3.5	—	—	V	5	—
		7.0	—	—		10	
		11.0	—	—		15	
Input low-level voltage	V _{IL}	—	—	1.5	V	5	—
		—	—	3.0		10	
		—	—	4.0		15	
Input high-level current	I _{IH}	—	—	0.3	μA	15	V _{IH} = 15V
Input low-level current	I _{IL}	—	—	- 0.3	μA	15	V _{IL} = 0V
RON resistance	R _{ON}	—	—	950	Ω	5	V _{IN} = V _{DD} / 2
		—	—	250		10	
		—	—	160		15	
RON resistance deflexion	ΔR _{ON}	—	10	—	Ω	5	—
		—	6	—		10	
		—	4	—		15	
OFF-channel leakage current	I _{OFF}	—	—	0.3	μA	15	—
		—	—	- 0.3		15	
Static current dissipation	I _{DD}	—	—	5	μA	5	V _i = V _{DD} or GND
		—	—	10		10	
		—	—	15		15	

Switching characteristics (unless otherwise noted, Ta = 25°C, VEE = VSS = 0V, RL = 1kΩ, CL = 50pF)

Parameter	Symbol	Min.	Typ.	Max.	Unit	VDD (V)	Conditions	Measurement circuit
						5		
Propagation delay time CHANNEL IN→OUT	tPLH	—	15	45	ns	5	—	Fig.4
	tPHL	—	8	20		10		
		—	6	15		15		
Propagation delay time CONT→OUT	tPHZ, tPLZ	—	170	550	ns	5	—	Fig.5, 6
	tPZH, tPZL	—	90	240		10		
		—	70	160		15		
Propagation delay time INHIBIT→OUT	tPHZ, tPLZ	—	150	380	ns	5	—	Fig.5, 6
	tPZH, tPZL	—	70	200		10		
		—	50	160		15		
Max. propagation frequency	fMax.	—	20	—	MHz	5	VEE = -5V*1	Fig.7
Feedthrough	FT	—	0.5	—	MHz	5	VEE = -5V*2	Fig.7
Sinewave distortion	D	—	0.02	—	%	5	VEE = -5V*3	Fig.7
Input capacitance (control)	Cc	—	5	—	pF	—	—	—
Input capacitance (switch)	Cs	—	10	—	pF	—	—	—

*1 VIN = 5VP-P sine wave, frequency that enables 20 log10 VOUT / VIN = - 3dB

*2 VIN = 5VP-P sine wave, frequency that enables 20 log10 VOUT / VIN = - 50dB at Channel off

*3 VIN = 5VP-P sine wave

●Measurement circuits

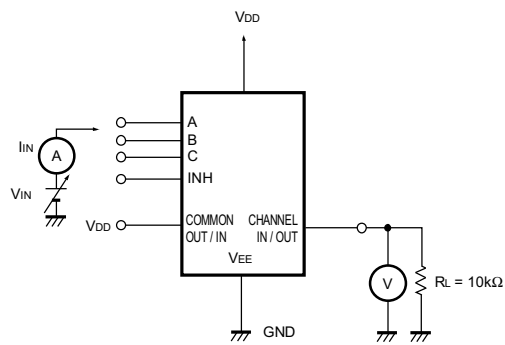

Fig. 1 Input voltage, current

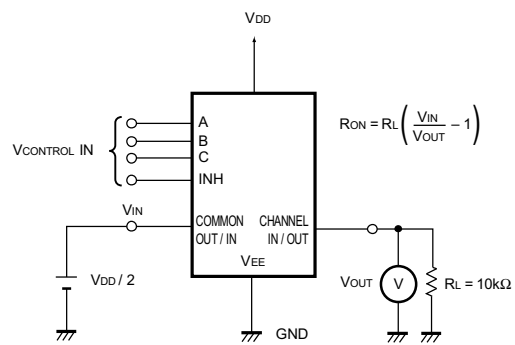

Fig. 2 ON resistance, ON resistance deviation

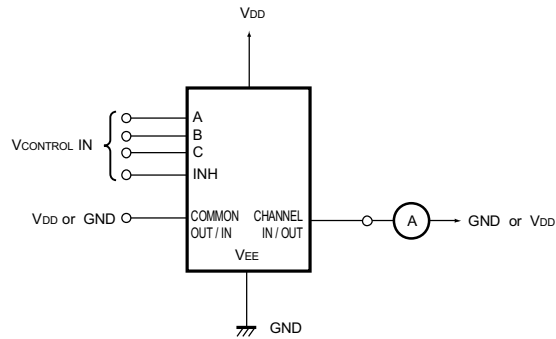

Fig. 3 OFF-channel leakage current

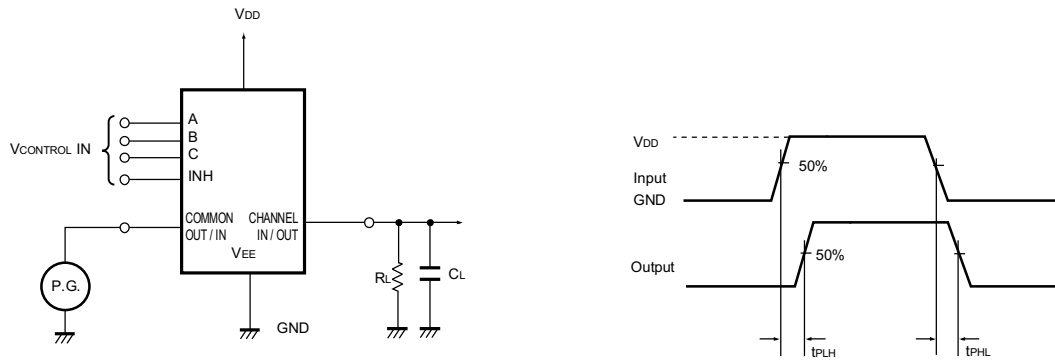

Fig. 4 Propagation delay time (Switch IN to OUT)

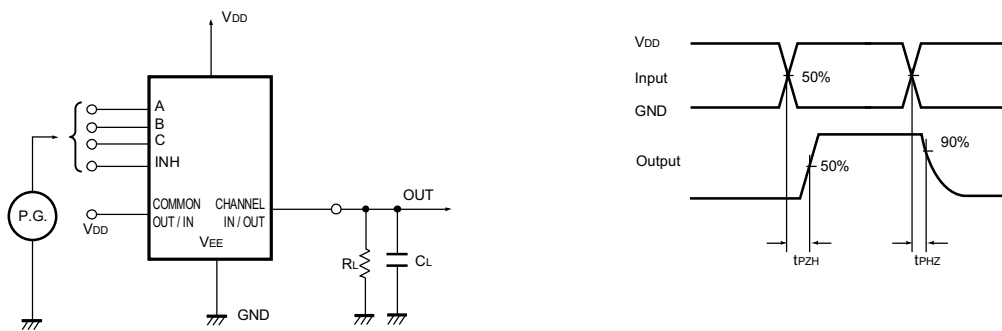

Fig. 5 Propagation delay time (CONT, INH to OUT)

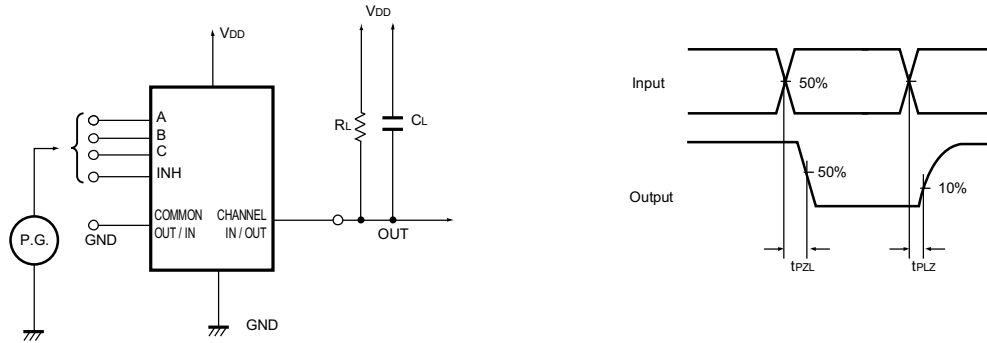

Fig. 6 Propagation delay time (CONT, INH to OUT)

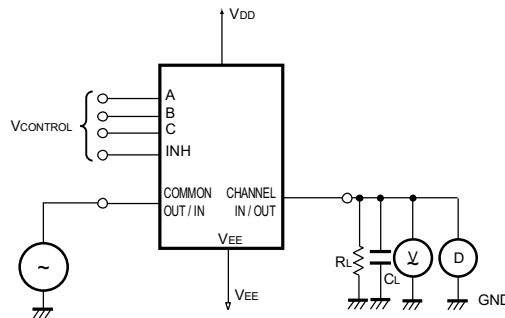

Fig. 7 Maximum propagation frequency, feedthrough attenuation, sine wave distortion

●Electrical characteristic curve

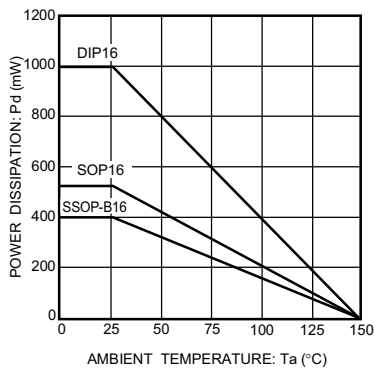

Fig. 8 Power dissipation vs. ambient temperature

● External dimensions (Units: mm)

