

# DATA SHEET

**BFS17**

**NPN 1 GHz wideband transistor**

Product specification  
File under Discrete Semiconductors, SC14

September 1995

## NPN 1 GHz wideband transistor

BFS17

## DESCRIPTION

NPN transistor in a plastic SOT23 package.

## APPLICATIONS

- A wide range of RF applications such as:
  - Mixers and oscillators in TV tuners
  - RF communications equipment.

## PINNING

| PIN | DESCRIPTION |
|-----|-------------|
| 1   | base        |
| 2   | emitter     |
| 3   | collector   |

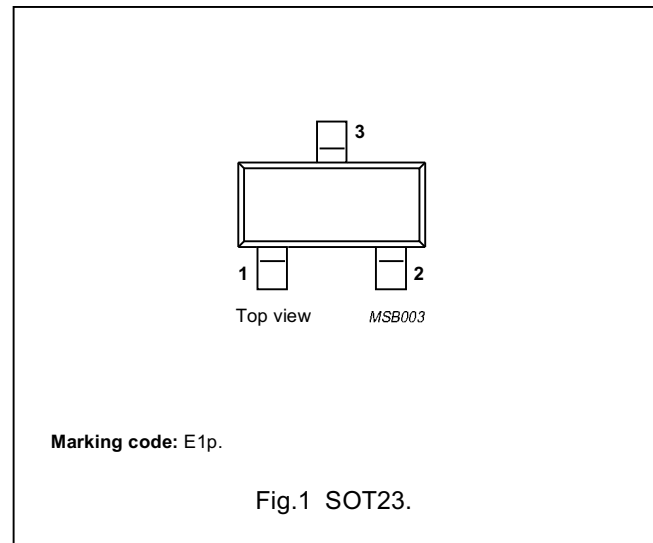

## QUICK REFERENCED DATA

| SYMBOL    | PARAMETER                 | CONDITIONS   | TYP. | MAX. | UNIT |
|-----------|---------------------------|--|------|------|------|
| $V_{CBO}$ | collector-base voltage    | open emitter   | –    | 25   | V    |
| $V_{CEO}$ | collector-emitter voltage | open base  | –    | 15   | V    |
| $I_C$     | DC collector current      |  | –    | 25   | mA   |
| $P_{tot}$ | total power dissipation   | up to $T_s = 70\text{ °C}$ ; note 1  | –    | 300  | mW   |
| $f_T$     | transition frequency      | $I_C = 25\text{ mA}$ ; $V_{CE} = 5\text{ V}$ ; $f = 500\text{ MHz}$ ; $T_j = 25\text{ °C}$                     | 1    | –    | GHz  |
| F         | noise figure              | $I_C = 2\text{ mA}$ ; $V_{CE} = 5\text{ V}$ ; $R_S = 50\ \Omega$ ; $f = 500\text{ MHz}$ ; $T_j = 25\text{ °C}$ | 4.5  | –    | dB   |

## LIMITING VALUES

In accordance with the Absolute Maximum Rating System (IEC 134).

| SYMBOL    | PARAMETER                 | CONDITIONS                          | MIN. | MAX. | UNIT |
|-----------|---------------------------|-------------------------------------|------|------|------|
| $V_{CBO}$ | collector-base voltage    | open emitter                        | –    | 25   | V    |
| $V_{CEO}$ | collector-emitter voltage | open base                           | –    | 15   | V    |
| $V_{EBO}$ | emitter-base voltage      | open collector                      | –    | 2.5  | V    |
| $I_C$     | DC collector current      |                                     | –    | 25   | mA   |
| $I_{CM}$  | peak collector current    |                                     | –    | 50   | mA   |
| $P_{tot}$ | total power dissipation   | up to $T_s = 70\text{ °C}$ ; note 1 | –    | 300  | mW   |
| $T_{stg}$ | storage temperature       |                                     | –65  | +150 | °C   |
| $T_j$     | junction temperature      |                                     | –    | 150  | °C   |

## Note to the Quick reference data and the Limiting values

1.  $T_s$  is the temperature at the soldering point of the collector pin.

## NPN 1 GHz wideband transistor

BFS17

## THERMAL CHARACTERISTICS

| SYMBOL        | PARAMETER   | CONDITIONS                          | VALUE | UNIT |
|---------------|---|-------------------------------------|-------|------|
| $R_{th\ j-s}$ | thermal resistance from junction to soldering point | up to $T_s = 70\text{ °C}$ ; note 1 | 260   | K/W  |

## Note

- $T_s$  is the temperature at the soldering point of the collector pin.

## CHARACTERISTICS

$T_j = 25\text{ °C}$  unless otherwise specified.

| SYMBOL    | PARAMETER                 | CONDITIONS  | MIN. | TYP. | MAX. | UNIT |
|-----------|---------------------------|---|------|------|------|------|
| $I_{CBO}$ | collector cut-off current | $I_E = 0$ ; $V_{CB} = 10\text{ V}$  | –    | –    | 10   | nA   |
| $h_{FE}$  | DC current gain           | $I_C = 2\text{ mA}$ ; $V_{CE} = 1\text{ V}$   | 25   | 90   | –    |      |
|           |                           | $I_C = 25\text{ mA}$ ; $V_{CE} = 1\text{ V}$  | 25   | 90   | –    |      |
| $f_T$     | transition frequency      | $I_C = 2\text{ mA}$ ; $V_{CE} = 5\text{ V}$ ; $f = 500\text{ MHz}$                            | –    | 1    | –    | GHz  |
|           |                           | $I_C = 25\text{ mA}$ ; $V_{CE} = 5\text{ V}$ ; $f = 500\text{ MHz}$                           | –    | 1.6  | –    | GHz  |
| $C_c$     | collector capacitance     | $I_E = i_e = 0$ ; $V_{CB} = 10\text{ V}$ ; $f = 1\text{ MHz}$                                 | –    | 0.8  | 1.5  | pF   |
| $C_e$     | emitter capacitance       | $I_C = i_c = 0$ ; $V_{EB} = 0.5\text{ V}$ ; $f = 1\text{ MHz}$                                | –    | –    | 2    | pF   |
| $C_{re}$  | feedback capacitance      | $I_C = 1\text{ mA}$ ; $V_{CE} = 5\text{ V}$ ; $f = 1\text{ MHz}$                              | –    | 0.65 | –    | pF   |
| F         | noise figure              | $I_C = 2\text{ mA}$ ; $V_{CE} = 5\text{ V}$ ; $R_S = 50\text{ }\Omega$ ; $f = 500\text{ MHz}$ | –    | 4.5  | –    | dB   |

NPN 1 GHz wideband transistor

BFS17

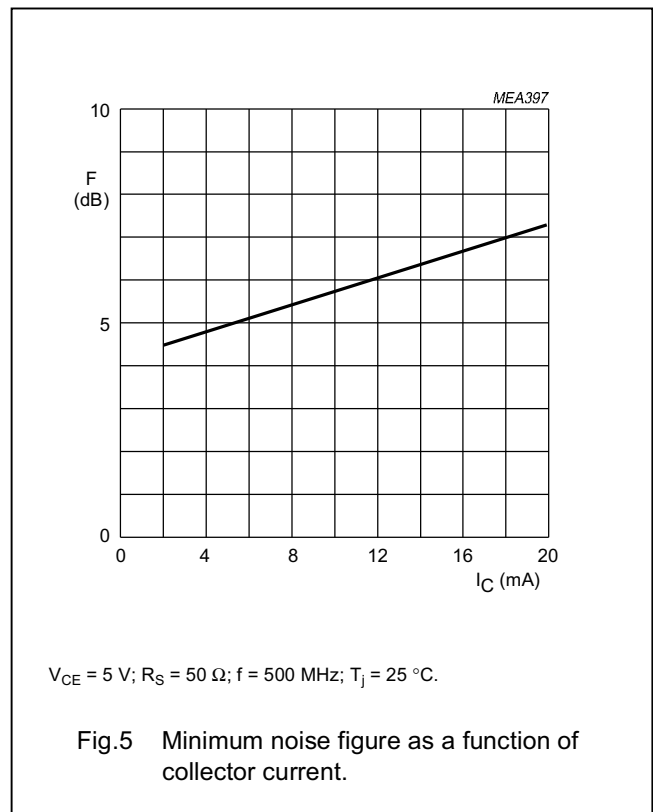
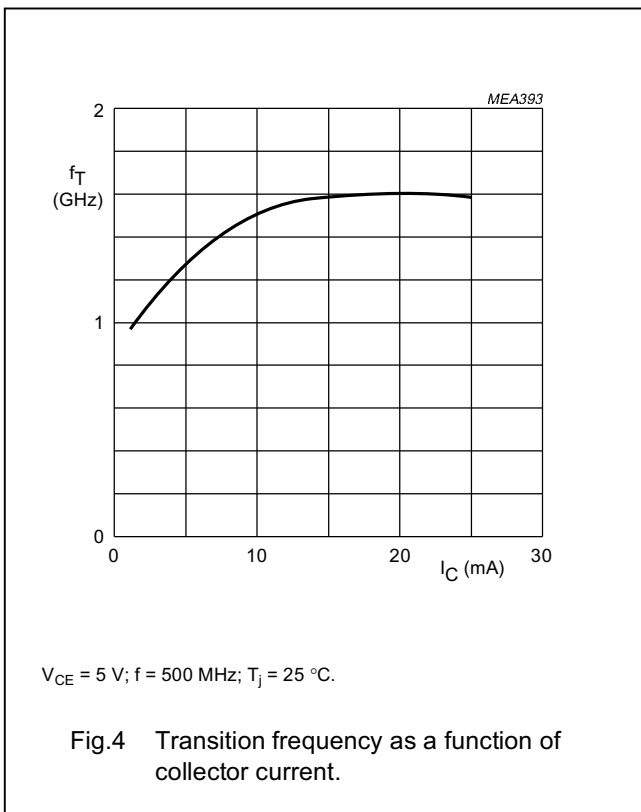
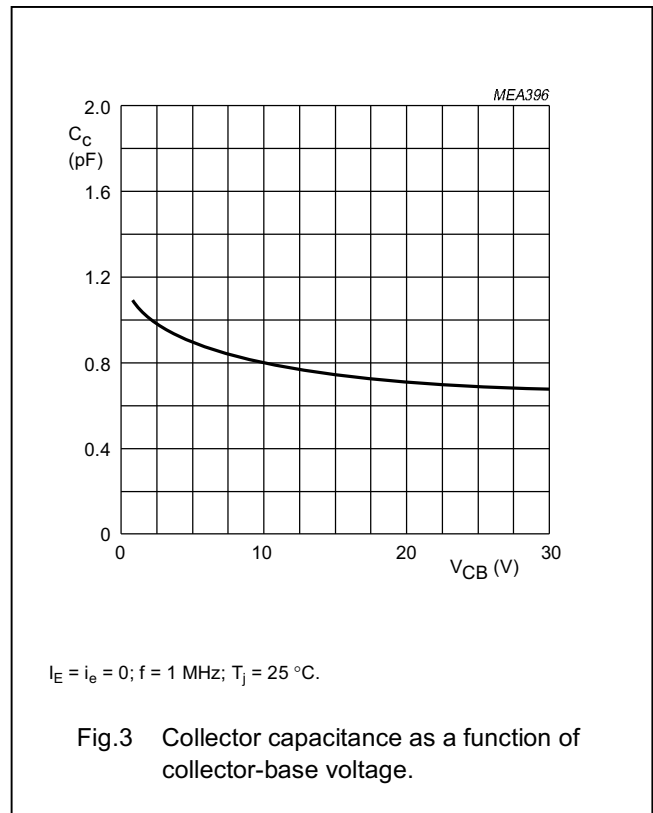
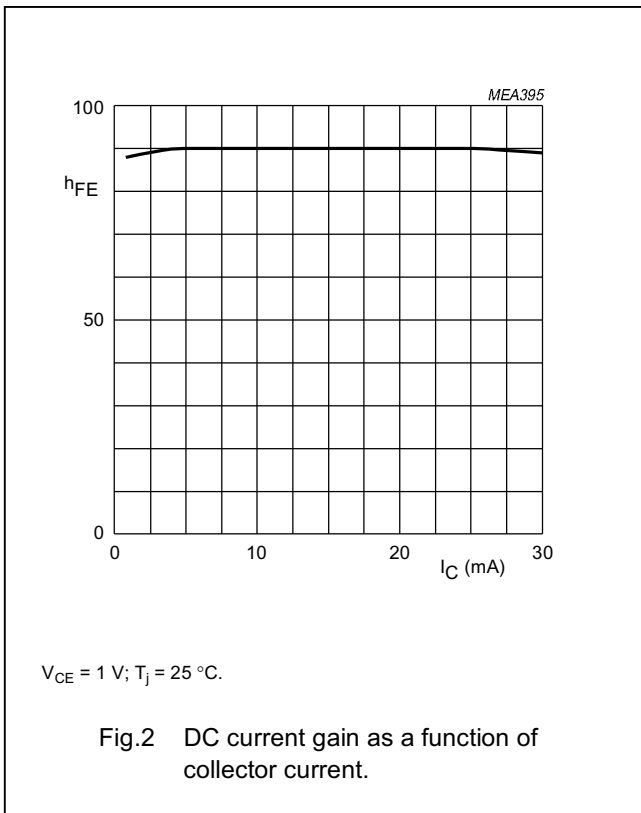

NPN 1 GHz wideband transistor

BFS17

PACKAGE OUTLINE

Plastic surface mounted package; 3 leads

SOT23

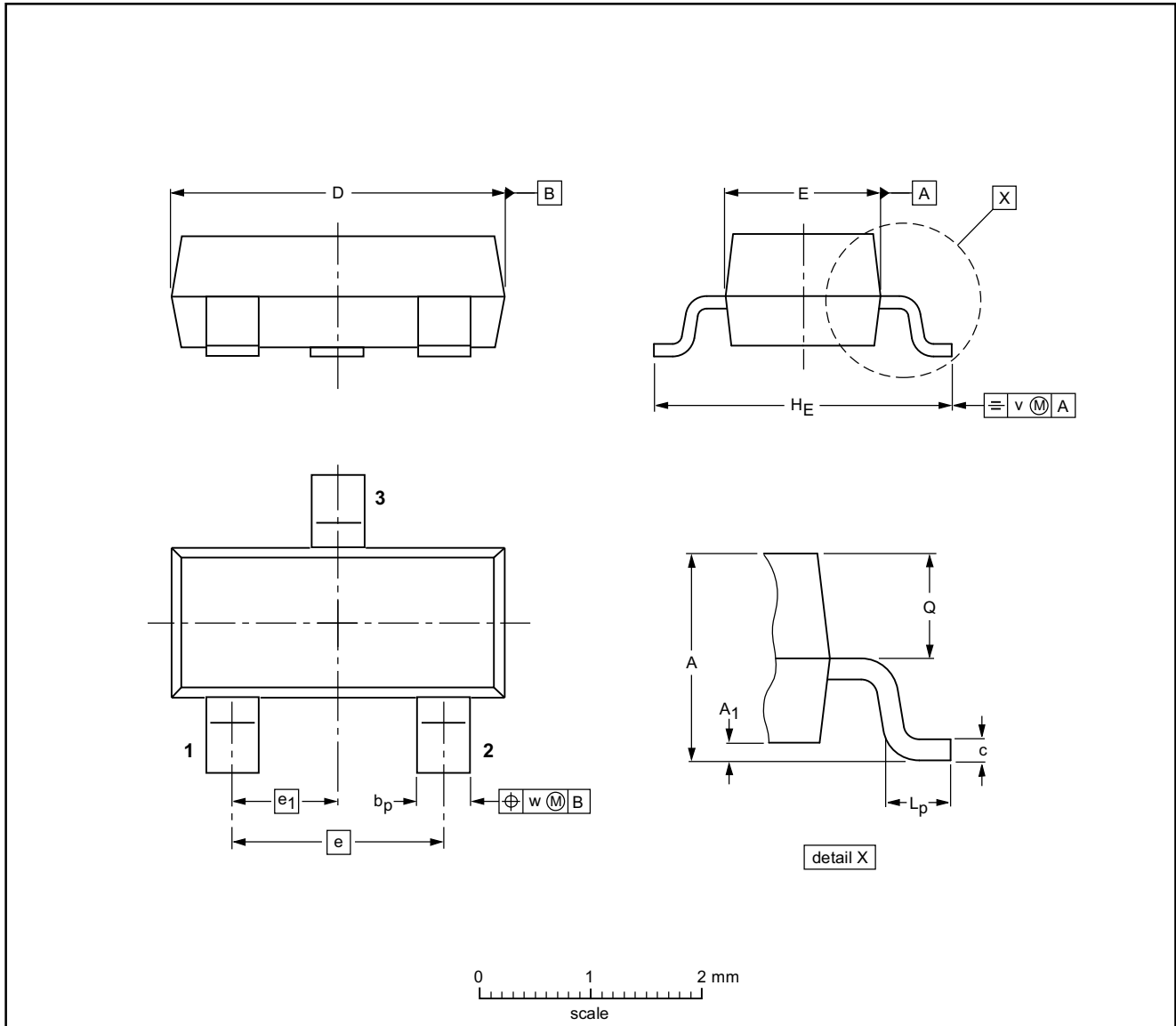

DIMENSIONS (mm are the original dimensions)

| UNIT | A          | A <sub>1</sub><br>max. | b <sub>p</sub> | c            | D          | E          | e   | e <sub>1</sub> | H <sub>E</sub> | L <sub>p</sub> | Q            | v   | w   |
|------|------------|------------------------|----------------|--------------|------------|------------|-----|----------------|----------------|----------------|--------------|-----|-----|
| mm   | 1.1<br>0.9 | 0.1                    | 0.48<br>0.38   | 0.15<br>0.09 | 3.0<br>2.8 | 1.4<br>1.2 | 1.9 | 0.95           | 2.5<br>2.1     | 0.45<br>0.15   | 0.55<br>0.45 | 0.2 | 0.1 |

| OUTLINE VERSION | REFERENCES |       |      |  | EUROPEAN PROJECTION | ISSUE DATE |
|-----------------|------------|-------|------|--|---------------------|------------|
|                 | IEC        | JEDEC | EIAJ |  |                     |            |
| SOT23           |            |       |      |  |                     | 97-02-28   |

## NPN 1 GHz wideband transistor

BFS17

**DEFINITIONS**

|   |   |
|---|---|
| <b>Data sheet status</b>  |   |
| Objective specification   | This data sheet contains target or goal specifications for product development.       |
| Preliminary specification   | This data sheet contains preliminary data; supplementary data may be published later. |
| Product specification   | This data sheet contains final product specifications.                                |
| <b>Limiting values</b>  |   |
| Limiting values given are in accordance with the Absolute Maximum Rating System (IEC 134). Stress above one or more of the limiting values may cause permanent damage to the device. These are stress ratings only and operation of the device at these or at any other conditions above those given in the Characteristics sections of the specification is not implied. Exposure to limiting values for extended periods may affect device reliability. |   |
| <b>Application information</b>  |   |
| Where application information is given, it is advisory and does not form part of the specification.   |   |

**LIFE SUPPORT APPLICATIONS**

These products are not designed for use in life support appliances, devices, or systems where malfunction of these products can reasonably be expected to result in personal injury. Philips customers using or selling these products for use in such applications do so at their own risk and agree to fully indemnify Philips for any damages resulting from such improper use or sale.