

**NPN Silicon Double Transistor**

- To be used as a current mirror
- Good thermal coupling and  $V_{BE}$  matching
- High current gain
- Low collector-emitter saturation voltage

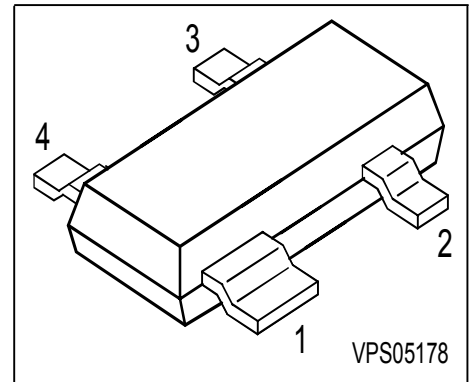
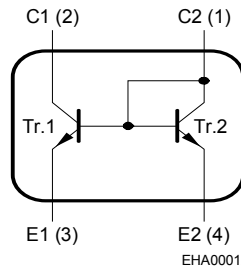

Type	Marking	Pin Configuration				Package
BCV61A	1Js	1 = C2	2 = C1	3 = E1	4 = E2	SOT143
BCV61B	1Ks	1 = C2	2 = C1	3 = E1	4 = E2	SOT143
BCV61C	1Ls	1 = C2	2 = C1	3 = E1	4 = E2	SOT143

**Maximum Ratings**

Parameter	Symbol	Value	Unit
Collector-emitter voltage (transistor T1)	$V_{CEO}$	30	V
Collector-base voltage (open emitter) (transistor T1)	$V_{CBO}$	30	
Emitter-base voltage	$V_{EBS}$	6	
DC collector current	$I_C$	100	mA
Peak collector current	$I_{CM}$	200	
Base peak current (transistor T1)	$I_{BM}$	200	
Total power dissipation, $T_S = 99\text{ °C}$	$P_{tot}$	300	mW
Junction temperature	$T_j$	150	°C
Storage temperature	$T_{stg}$	-65 ... 150	

**Thermal Resistance**

Junction - soldering point <sup>1)</sup>	$R_{thJS}$	≤170	K/W
--	------------	------	-----

<sup>1)</sup>For calculation of  $R_{thJA}$  please refer to Application Note Thermal Resistance

**Electrical Characteristics** at  $T_A = 25^\circ\text{C}$ , unless otherwise specified

Parameter	Symbol	Values			Unit
		min.	typ.	max.	
<b>DC Characteristics of T1</b>					
Collector-emitter breakdown voltage $I_C = 10\text{ mA}, I_B = 0$	$V_{(BR)CEO}$	30	-	-	V
Collector-base breakdown voltage $I_C = 10\text{ }\mu\text{A}, I_B = 0$	$V_{(BR)CBO}$	30	-	-	
Emitter-base breakdown voltage $I_E = 10\text{ }\mu\text{A}, I_C = 0$	$V_{(BR)EBO}$	6	-	-	
Collector cutoff current $V_{CB} = 30\text{ V}, I_E = 0$	$I_{CBO}$	-	-	15	nA
Collector cutoff current $V_{CB} = 30\text{ V}, I_E = 0, T_A = 150\text{ }^\circ\text{C}$	$I_{CBO}$	-	-	5	$\mu\text{A}$
DC current gain 1) $I_C = 0.1\text{ mA}, V_{CE} = 5\text{ V}$	$h_{FE}$	100	-	-	-
DC current gain 1) $I_C = 2\text{ mA}, V_{CE} = 5\text{ V}$	$h_{FE}$				
	BCV61A	110	180	220	
	BCV61B	200	290	450	
	BCV61C	420	520	800	
Collector-emitter saturation voltage1) $I_C = 10\text{ mA}, I_B = 0.5\text{ mA}$ $I_C = 100\text{ mA}, I_B = 5\text{ mA}$	$V_{CEsat}$	-	90	250	mV
		-	200	600	
Base-emitter saturation voltage 1) $I_C = 10\text{ mA}, I_B = 0.5\text{ mA}$ $I_C = 100\text{ mA}, I_B = 5\text{ mA}$	$V_{BEsat}$	-	700	-	
		-	900	-	
Base-emitter voltage 1) $I_C = 2\text{ mA}, V_{CE} = 5\text{ V}$ $I_C = 10\text{ mA}, V_{CE} = 5\text{ V}$	$V_{BE(ON)}$	580	660	700	
		-	-	770	

 1) Pulse test:  $t \leq 300\mu\text{s}$ ,  $D = 2\%$

**Electrical Characteristics** at  $T_A = 25^\circ\text{C}$ , unless otherwise specified.

Parameter	Symbol	Values			Unit
		min.	typ.	max.	
<b>Characteristics</b>					
Base-emitter forward voltage $I_E = 10 \mu\text{A}$ $I_E = 250 \text{ mA}$	$V_{\text{BES}}$	0.4 -	- -	- 1.8	V
Matching of transistor T1 and transistor T2 at $I_{E2} = 0.5\text{mA}$ and $V_{\text{CE1}} = 5\text{V}$ $T_A = 25^\circ\text{C}$ $T_A = 150^\circ\text{C}$	$I_{C1} / I_{C2}$	- 0.7 0.7	- - -	- 1.3 1.3	-
Thermal coupling of transistor T1 and transistor T2 1) T1: $V_{\text{CE}} = 5\text{V}$ Maximum current of thermal stability of $I_{C1}$	$I_{E2}$	-	5	-	mA
<b>AC characteristics for transistor T1</b>					
Transition frequency $I_C = 10 \text{ mA}$ , $V_{\text{CE}} = 5 \text{ V}$ , $f = 100 \text{ MHz}$	$f_T$	-	250	-	MHz
Collector-base capacitance $V_{\text{CB}} = 10 \text{ V}$ , $f = 1 \text{ MHz}$	$C_{\text{cb}}$	-	3	-	pF
Emitter-base capacitance $V_{\text{EB}} = 0.5 \text{ V}$ , $f = 1 \text{ MHz}$	$C_{\text{eb}}$	-	8	-	
Noise figure $I_C = 200 \mu\text{A}$ , $V_{\text{CE}} = 5 \text{ V}$ , $R_S = 2 \text{ k}\Omega$ , $f = 1 \text{ kHz}$ , $\Delta f = 200 \text{ Hz}$	$F$	-	2	-	dB
Short-circuit input impedance $I_C = 1 \text{ mA}$ , $V_{\text{CE}} = 10 \text{ V}$ , $f = 1 \text{ kHz}$	$h_{11e}$	-	4.5	-	k $\Omega$
Open-circuit reverse voltage transf.ratio $I_C = 1 \text{ mA}$ , $V_{\text{CE}} = 10 \text{ V}$ , $f = 1 \text{ kHz}$	$h_{12e}$	-	2	-	$10^{-4}$
Short-circuit forward current transf.ratio $I_C = 1 \text{ mA}$ , $V_{\text{CE}} = 10 \text{ V}$ , $f = 1 \text{ kHz}$	$h_{21e}$	100	-	900	-
Open-circuit output admittance $I_C = 1 \text{ mA}$ , $V_{\text{CE}} = 10 \text{ V}$ , $f = 1 \text{ kHz}$	$h_{22e}$	-	30	-	$\mu\text{S}$

1) Witout emitter resistor. Device mounted on alumina 15mm x 16.5mm x 0.7mm

**Test circuit for current matching**

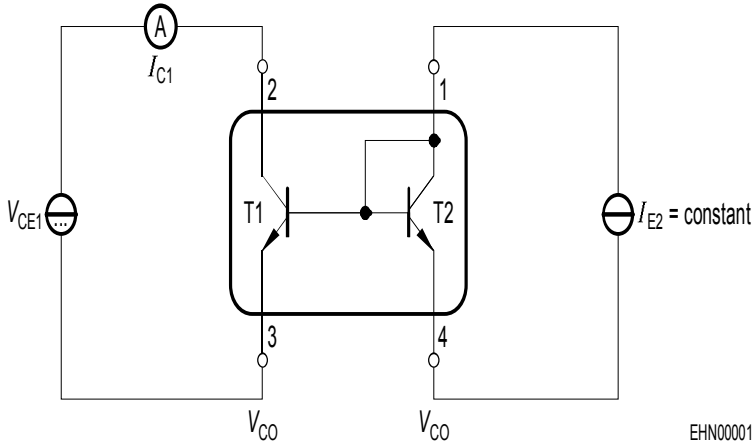

Note: Voltage drop at contacts:  $V_{CO} < 2/3 V_T = 16\text{mV}$

**Characteristic for determination of  $V_{CE1}$  at specified  $R_E$  range with  $I_{E2}$  as parameter under condition of  $I_{C1}/I_{E2} = 1.3$**

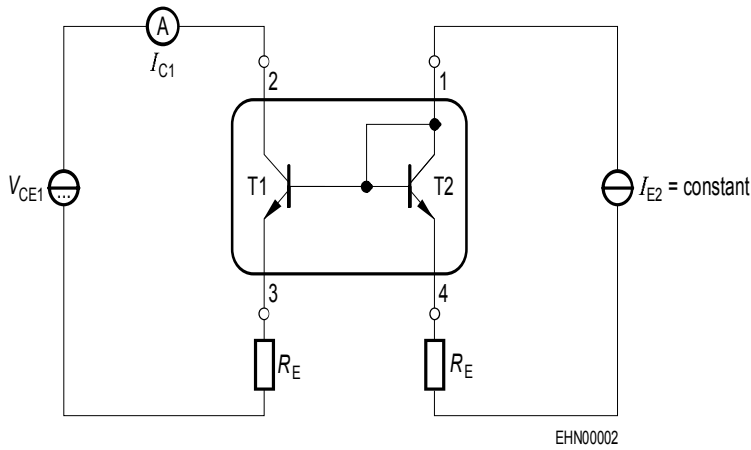

Note: BCV61 with emitter resistors

**Total power dissipation  $P_{tot} = f(T_S)$**

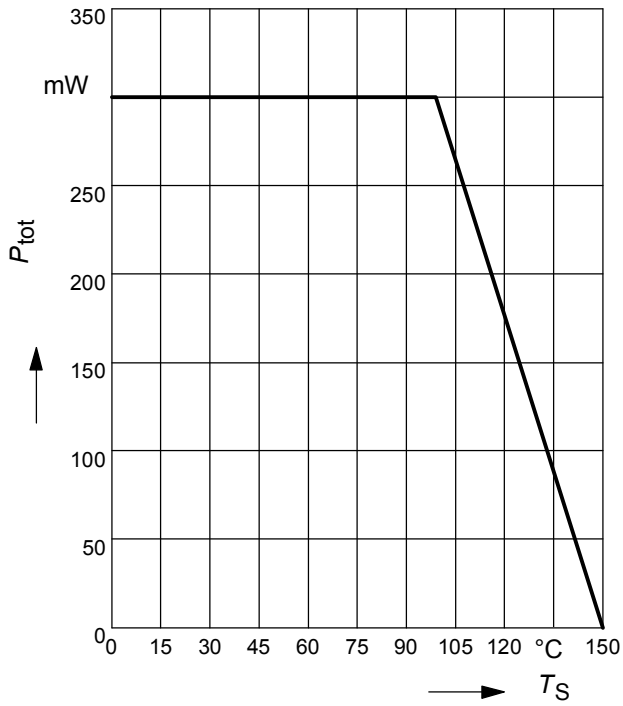

**Permissible pulse load**

$P_{totmax} / P_{totDC} = f(t_p)$

