

Device Features

- Fully qualified Bluetooth v1.2 system
- Bluetooth v1.1 and v1.2 specification compliant
- 1.8V core, 1.8 to 3.6V I/O
- Ultra low power consumption
- Excellent compatibility with cellular telephones
- Minimum external components
- Integrated 1.8V regulator
- Dual UART ports
- Available in VFBGA
- Built-in self-test reduces production test times
- RoHS Compliant (BC313143AXX-IRK-E4)
- Software prototyping device available (BlueCore3-ROM Flash)

General Description

BlueCore3-ROM is a single chip radio and baseband chip for Bluetooth wireless technology 2.4GHz systems. It is implemented in 0.18µm CMOS technology.

BlueCore3-ROM has the same pin out as BlueCore2-ROM (VFBGA Package) but uses up to 40% less power.

The 4Mbit ROM is metal programmable, which enables a eight week turn-around from approval of firmware to production samples.

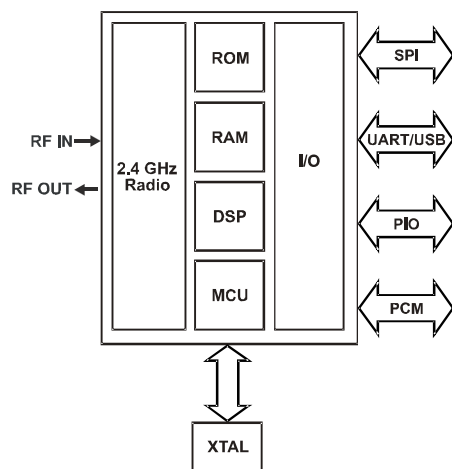

BlueCore3-ROM System Architecture

BlueCore™3-ROM

Single Chip Bluetooth® v1.2 System

Production Information Data Sheet for

BC313143A

July 2005

BC313143AXX

BC31A159A-ES-ITK

Applications

- Cellular Handsets
- Personal Digital Assistants (PDAs)
- Mice and game pads
- Digital cameras and other high volume consumer products

A Flash based prototyping device (BlueCore3-ROM Flash) is available for functional verification and testing of the firmware prior to committing the image to ROM.

BlueCore3-ROM has been designed to reduce the number of external components required, which ensures production costs are minimised.

The device incorporates auto-calibration and built-in self-test (BIST) routines to simplify development, type approval and production test. All hardware and device firmware is fully compliant with the Bluetooth specification v1.2.

Contents

Status Information	7
1 Key Features	8
2 6 x 6mm Package Information	9
2.1 BC313143AXX-IEK and BC313143AXX-IRK Pinout Diagram	9
2.2 Device Terminal Functions	10
3 6.5 x 6.5mm Package Information	14
3.1 BlueCore3-ROM Flash Pinout Diagram	14
3.2 Device Terminal Functions	15
4 Electrical Characteristics	19
5 Radio Characteristics	24
5.1 Temperature +20°C	24
5.1.1 Transmitter	24
5.1.2 Receiver	26
5.2 Temperature -40°C	28
5.2.1 Transmitter	28
5.2.2 Receiver	28
5.3 Temperature -30°C	29
5.3.1 Transmitter	29
5.3.2 Receiver	29
5.4 Temperature -25°C	30
5.4.1 Transmitter	30
5.4.2 Receiver	30
5.5 Temperature +85°C	31
5.5.1 Transmitter	31
5.5.2 Receiver	33
5.6 Temperature +105°C	34
5.6.1 Transmitter	34
5.6.2 Receiver	34
5.7 Power Consumption	35
6 Device Diagrams	36
6.1 BlueCore3-ROM	36
6.2 BlueCore3-ROM Flash	37
7 Description of Functional Blocks	38
7.1 RF Receiver	38
7.1.1 Low Noise Amplifier	38
7.1.2 Analogue to Digital Converter	38
7.2 RF Transmitter	38
7.2.1 IQ Modulator	38
7.2.2 Power Amplifier	38
7.2.3 Auxiliary DAC	38
7.3 RF Synthesiser	38
7.4 Clock Input and Generation	38
7.5 Baseband and Logic	39
7.5.1 Memory Management Unit	39
7.5.2 Burst Mode Controller	39
7.5.3 Physical Layer Hardware Engine DSP	39
7.5.4 RAM	39
7.5.5 ROM	39
7.5.6 Flash (BlueCore3-ROM Flash Only)	39
7.5.7 USB	39
7.5.8 Synchronous Serial Interface	40
7.5.9 UART	40
7.5.10 Audio PCM Interface	40
7.6 Microcontroller	40
7.6.1 Programmable I/O	40

8	CSR Bluetooth Software Stacks	41
8.1	BlueCore HCI Stack.....	41
8.1.1	Key Features of the HCI Stack	42
8.2	BlueCore RFCOMM Stack.....	44
8.2.1	Key Features of the BlueCore3-ROM RFCOMM Stack	44
8.3	BlueCore Virtual Machine Stack	45
8.4	BlueCore HID Stack.....	46
8.5	BCHS Software.....	47
8.6	Additional Software for Other Embedded Applications	47
8.7	CSR Development Systems	47
9	Device Terminal Descriptions	48
9.1	RF Ports.....	48
9.2	Transmitter/Receiver Inputs and Outputs	48
9.2.1	Transmitter S-Parameters.....	49
9.2.2	Receiver S-Parameters	53
9.2.3	Single Ended Impedance.....	55
9.3	External Reference Clock Input (XTAL_IN)	56
9.3.1	External Mode.....	56
9.3.2	XTAL_IN Impedance in External Mode.....	56
9.3.3	Clock Timing Accuracy	57
9.3.4	Clock Start-Up Delay	57
9.3.5	Input Frequencies and PS Key Settings	58
9.4	Crystal Oscillator (XTAL_IN, XTAL_OUT)	59
9.4.1	XTAL Mode.....	59
9.4.2	Load Capacitance.....	60
9.4.3	Frequency Trim.....	60
9.4.4	Transconductance Driver Model	61
9.4.5	Negative Resistance Model	61
9.4.6	Crystal PS Key Settings.....	61
9.4.7	Crystal Oscillator Characteristics	62
9.5	UART Interface	65
9.5.1	UART Bypass	67
9.5.2	UART Configuration while RESET is Active	67
9.5.3	UART Bypass Mode	67
9.5.4	Current Consumption in UART Bypass Mode.....	67
9.6	USB Interface	68
9.6.1	USB Data Connections.....	68
9.6.2	USB Pull-Up Resistor	68
9.6.3	Power Supply.....	68
9.6.4	Self Powered Mode	69
9.6.5	Bus Powered Mode	70
9.6.6	Suspend Current.....	71
9.6.7	Detach and Wake_Up Signalling	71
9.6.8	USB Driver.....	71
9.6.9	USB 1.1 Compliance	72
9.6.10	USB 2.0 Compatibility.....	72
9.7	Serial Peripheral Interface	72
9.7.1	Instruction Cycle	72
9.7.2	Writing to BlueCore3-ROM	73
9.7.3	Reading from BlueCore3-ROM.....	73
9.7.4	Multi Slave Operation	73
9.7.5	PCM CODEC Interface.....	74
9.7.6	PCM Interface Master/Slave	75
9.7.7	Long Frame Sync	76
9.7.8	Short Frame Sync.....	76
9.7.9	Multi Slot Operation	77
9.7.10	GCI Interface	77
9.7.11	Slots and Sample Formats.....	78
9.7.12	Additional Features.....	78
9.7.13	PCM Timing Information	79

9.7.14	PCM Slave Timing	81
9.7.15	PCM_CLK and PCM_SYNC Generation	82
9.7.16	PCM Configuration	83
9.8	I/O Parallel Ports	85
9.9	I ² C Interface	86
9.10	TCXO Enable OR Function	86
9.11	RESET and RESETB	87
9.11.1	Pin States on Reset	88
9.11.2	Status after Reset	88
9.12	Power Supply	89
9.12.1	Voltage Regulator	89
9.12.2	Sequencing	89
9.12.3	Sensitivity to Disturbances	89
10	Application Schematic	90
10.1	6 x 6mm VFBGA 84-Ball Package	90
11	PCB Design and Assembly Considerations	91
11.1	VFBGA 84-Ball Package	91
12	Package Dimensions	92
12.1	6 x 6mm VFBGA 84-Ball Package	92
12.2	6.5 x 6.5mm VFBGA 84-Ball Package	93
13	Solder Profiles	94
13.1	Example Solder Re-flow Profile for Devices with Lead-Free Solder Balls	94
13.2	Example Solder Re-Flow Profile for Devices with Tin / Lead Solder Balls	95
14	Product Reliability Tests	96
15	Ordering Information	97
15.1	BlueCore3-ROM	97
15.2	BlueCore3-ROM Flash Software Prototyping Device	97
16	Tape and Reel Information	98
16.1	Tape Orientation and Dimensions	98
16.2	Reel Information	100
16.3	Dry Pack Information (6 x 6mm VFBGA 84-Ball Package Only)	101
16.4	Baking Conditions	102
16.5	Product Information	102
17	Contact Information	103
18	Document References	104
	Terms and Definitions	105
	Document History	108

List of Figures

Figure 2.1: BlueCore3-ROM 6 x 6mm Packages (BC313143AXX-IEK and BC313143AXX-IRK)..... 9

Figure 3.1: BlueCore3-ROM Flash 6.5 x 6.5mm Packages (BC31A159A-ES-ITK)..... 14

Figure 6.1: BlueCore3-ROM Device Diagram for 6 x 6mm VFBGA Packages 36

Figure 6.2: BlueCore3-ROM Flash Device Diagram for 6.5 x 6.5mm TFBGA Packages 37

Figure 8.1: BlueCore HCI Stack 41

Figure 8.2: BlueCore RFCOMM Stack 44

Figure 8.3: Virtual Machine 45

Figure 8.4: HID Stack..... 46

Figure 9.1: Circuit TX/RX_A and TX/RX_B 48

Figure 9.2: Circuit RF_IN 48

Figure 9.3: TX_A PL35..... 50

Figure 9.4: TX_A PL50..... 50

Figure 9.5: TX_A PL63..... 51

Figure 9.6: TX_B PL35..... 51

Figure 9.7: TX_B PL50..... 52

Figure 9.8: TX_B PL63..... 52

Figure 9.9: RX_A Balanced..... 54

Figure 9.10: RX_B Balanced..... 54

Figure 9.11: RX Un-Balanced 55

Figure 9.12: TCXO Clock Accuracy 57

Figure 9.13: Actual Allowable Clock Presence Delay on XTAL_IN vs. PS Key Setting..... 57

Figure 9.14: Crystal Driver Circuit 59

Figure 9.15: Crystal Equivalent Circuit 59

Figure 9.16: Crystal Load Capacitance and Series Resistance Limits with Crystal Frequency..... 62

Figure 9.17: Crystal Driver Transconductance vs. Driver Level Register Setting 63

Figure 9.18: Crystal Driver Negative Resistance as a Function of Drive Level Setting 64

Figure 9.19: Universal Asynchronous Receiver 65

Figure 9.20: Break Signal..... 66

Figure 9.21: UART Bypass Architecture 67

Figure 9.22: USB Connections for Self Powered Mode 69

Figure 9.23: USB Connections for Bus Powered Mode 70

Figure 9.24: USB_DETACH and USB_WAKE_UP Signal 71

Figure 9.25: Write Operation 73

Figure 9.26: Read Operation..... 73

Figure 9.27: BlueCore3-ROM as PCM Interface Master 75

Figure 9.28: BlueCore3-ROM as PCM Interface Slave 75

Figure 9.29: Long Frame Sync (Shown with 8-bit Companded Sample)..... 76

Figure 9.30: Short Frame Sync (Shown with 16-bit Sample) 76

Figure 9.31: Multi Slot Operation with Two Slots and 8-bit Companded Samples 77

Figure 9.32: GCI Interface..... 77

Figure 9.33: 16-Bit Slot Length and Sample Formats 78

Figure 9.34: PCM Master Timing Long Frame Sync 80

Figure 9.35: PCM Master Timing Short Frame Sync..... 80

Figure 9.36: PCM Slave Timing Long Frame Sync 81

Figure 9.37: PCM Slave Timing Short Frame Sync..... 82

Figure 9.38: Example EEPROM Connection 86

Figure 9.39: Example TXCO Enable OR Function 86

Figure 11.1: Application Circuit for Radio Characteristics Specification for 6 x 6mm VFBGA Package 90

Figure 13.1: BlueCore3-ROM VFBGA Package Dimensions 92

Figure 13.2: BlueCore3-ROM Flash TFBGA Package Dimensions 93

Figure 14.1: Typical Lead-Free Re-flow Solder Profile 94

Figure 14.2: Typical Re-flow Solder Profile 95

Figure 17.1: Tape and Reel Orientation 98

Figure 17.2: Tape Dimensions 99

Figure 17.3: Reel Dimensions 100

Figure 17.4: Tape and Reel Packaging 101

Figure 17.5: Product Information Labels 102

List of Tables

Table 9.1: Transmit Impedance 49

Table 9.2: Balanced Receiver Impedance 53

Table 9.3: Single Ended Impedance 55

Table 9.4: External Clock Specifications 56

Table 9.5: PS Key Values for CDMA/3G phone TCXO Frequencies 58

Table 9.6: Crystal Oscillator Specification 61

Table 9.7: Possible UART Settings 65

Table 9.8: Standard Baud Rates 66

Table 9.9: USB Interface Component Values 70

Table 9.10: Instruction Cycle for an SPI Transaction 72

Table 9.11: PCM Master Timing 79

Table 9.12: PCM Slave Timing 81

Table 9.13: PSKEY_PCM_CONFIG32 Description 83

Table 9.14: PSKEY_PCM_LOW_JITTER_CONFIG Description 84

Table 9.15: Pin States of BlueCore3-ROM on Reset 88

Table 17.1: Reel Dimensions 100

Table 17.2: Diameter Dependent Dimensions 100

Status Information

The status of this Data Sheet is **Production Information**.

CSR Product Data Sheets progress according to the following format:

Advance Information

Information for designers concerning CSR product in development. All values specified are the target values of the design. Minimum and maximum values specified are only given as guidance to the final specification limits and must not be considered as the final values.

All detailed specifications including pinouts and electrical specifications may be changed by CSR without notice.

Pre-Production Information

Pinout and mechanical dimension specifications finalised. All values specified are the target values of the design. Minimum and maximum values specified are only given as guidance to the final specification limits and must not be considered as the final values.

All electrical specifications may be changed by CSR without notice.

Production Information

Final Data Sheet including the guaranteed minimum and maximum limits for the electrical specifications. Production Data Sheets supersede all previous document versions.

RoHS Compliance

BlueCore4-ROM devices meet the requirements of Directive 2002/95/EC of the European Parliament and of the Council on the Restriction of Hazardous Substance (RoHS).

Trademarks, Patents and Licenses

Unless otherwise stated, words and logos marked with TM or ® are trademarks registered or owned by Cambridge Silicon Radio Limited or its affiliates. Bluetooth® and the Bluetooth logos are trademarks owned by Bluetooth SIG, Inc. and licensed to CSR. Other products, services and names used in this document may have been trademarked by their respective owners.

Windows®, Windows 98TM, Windows 2000TM, Windows XPTM and Windows NTTM are registered trademarks of the Microsoft Corporation.

OMAPTM is a trademark of Texas Instruments Inc.

The publication of this information does not imply that any license is granted under any patent or other rights owned by Cambridge Silicon Radio Limited.

CSR reserves the right to make technical changes to its products as part of its development programme.

While every care has been taken to ensure the accuracy of the contents of this document, CSR cannot accept responsibility for any errors.

CSR's products are not authorised for use in life-support or safety-critical applications.

1 Key Features

Radio

- Common TX/RX terminals simplifies external matching; eliminates external antenna switch
- BIST minimises production test time. No external trimming is required in production
- Full RF reference designs are available
- Bluetooth v1.2 specification compliant

Transmitter

- +6dBm RF transmit power with level control from on-chip 6-bit DAC over a dynamic range >30dB
- Class 2 and Class 3 support without the need for an external power amplifier or TX/RX switch
- Class 1 support using external power amplifier, with RF power controlled by an internal 8-bit DAC.

Receiver

- Integrated channel filters
- Digital demodulator for improved sensitivity and co-channel rejection
- Real time digitised RSSI available on HCI interface
- Fast AGC for enhanced dynamic range

Synthesiser

- Fully integrated synthesizer requires no external VCO varactor diode, resonator or loop filter
- Compatible with crystals between 8 and 32MHz (in multiples of 250kHz) or an external clock
- Accepts 15.36, 16.2, 16.8, 19.2, 19.44, 19.68, 19.8 and 38.4MHz TCXO frequencies for GSM and CDMA devices with either sinusoidal or logic level signals

Auxiliary Features

- Crystal oscillator with built-in digital trimming
- Power management includes digital shut down and wake up commands with an integrated low power oscillator for ultra-low Park/Sniff/Hold mode
- 'Clock request' output to control an external clock source
- Device can run in low power modes from an external 32768Hz clock signal
- Auto Baud Rate setting for different TCXO frequencies
- On-chip linear regulator, producing 1.8V output from 2.2 - 4.2V input

Auxiliary Features (Continued)

- Power-on-reset cell detects low supply voltage
- Arbitrary sequencing of power supplies is permitted
- Uncommitted 8-bit ADC and 8-bit DAC are available to application programs

Baseband and Software

- Internal programmed 4Mbit ROM for complete system solution
- BlueCore3-ROM Flash device for software prototyping
- 32kbyte on-chip RAM allows full speed Bluetooth data transfer, mixed voice and data, plus full seven slave Piconet operation
- Dedicated logic for forward error correction, header error control, access code correlation, demodulation, cyclic redundancy check, encryption bit stream generation, whitening and transmit pulse shaping. Supports all Bluetooth 1.2 features including eSCO
- Transcoders for A-law, μ -law and linear voice from host and A-law, μ -law and CVSD voice over air

Physical Interfaces

- Synchronous serial interface up to 4M Baud for system debugging
- UART interface with programmable Baud rate up to 1.5M Baud with an optional bypass mode
- Full speed USB interface supports OHCI and UHCI host interfaces. Compliant with USB v2.0
- Synchronous bi-directional serial programmable audio interface
- Optional I²C™ compatible interface

Bluetooth Stack Running on an Internal Microcontroller

CSR's Bluetooth protocol stack runs on-chip in a variety of configurations:

- Standard HCI (UART or USB)
- Fully embedded to RFCOMM
- Customer specific builds with embedded application code

Package Options

- 84-ball VFBGA 6 x 6 x 1.0mm 0.5mm pitch (BlueCore3-ROM)
- 84-ball TFBGA 6.5 x 6.5 x 1.2mm 0.5mm pitch (BlueCore3-ROM Flash for software prototyping)

2 6 x 6mm Package Information

2.1 BC313143AXX-IEK and BC313143AXX-IRK Pinout Diagram

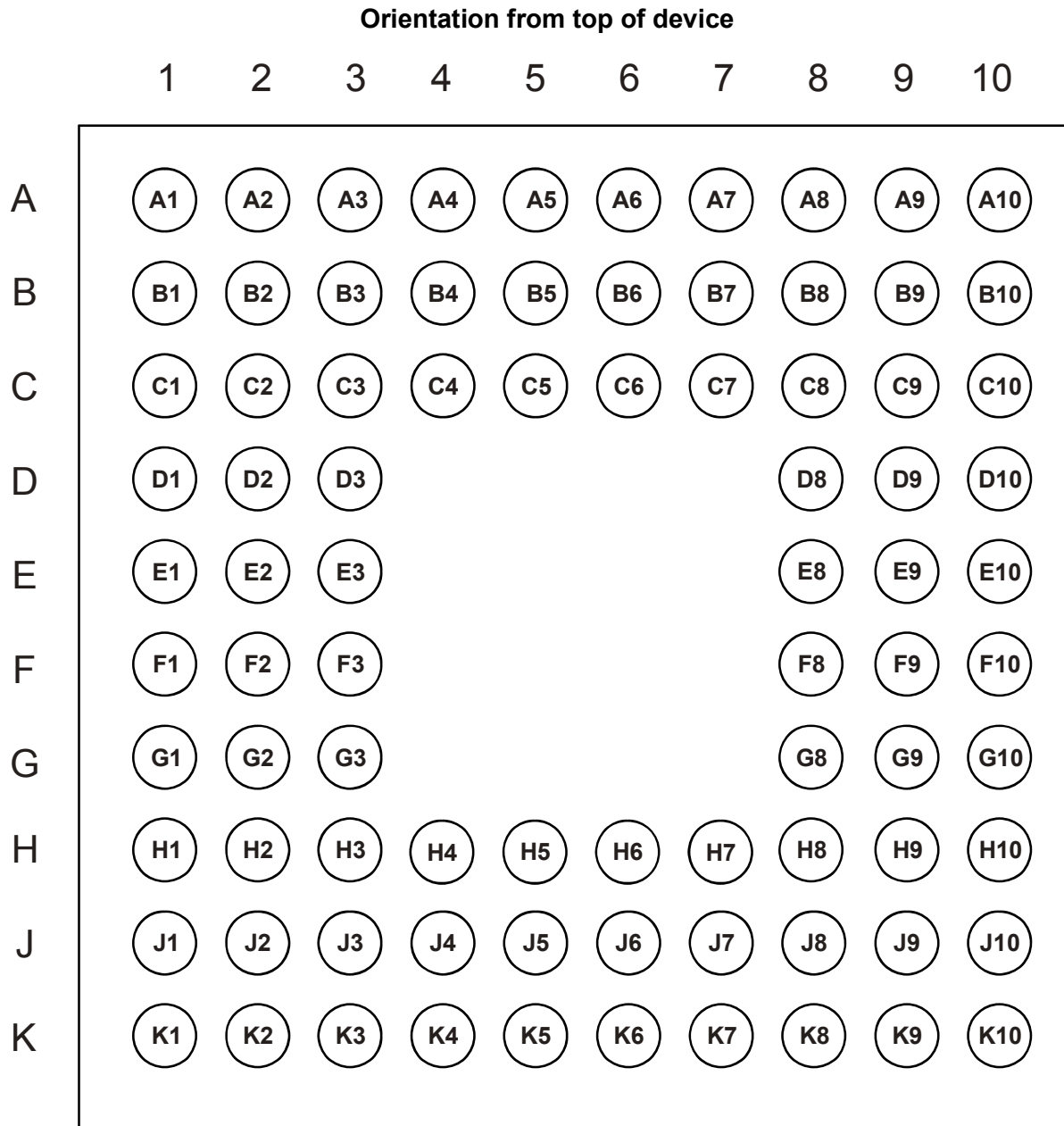

Figure 2.1: BlueCore3-ROM 6 x 6mm Packages (BC313143AXX-IEK and BC313143AXX-IRK)

2.2 Device Terminal Functions

Radio	Ball	Pad Type	Description
RF_IN	D1	Analogue	Single-ended receiver input
PIO[0]/RXEN	B1	Bi-directional with programmable strength internal pull-up/down	Control output for external TX/RX switch (if fitted)
PIO[1]/TXEN	B2	Bi-directional with programmable strength internal pull-up/down	Control output for external PA (if fitted)
TX_A	F1	Analogue	Transmitter output/switched receiver input
TX_B	E1	Analogue	Complement of TX_A
AUX_DAC	D3	Analogue	Voltage DAC output

Synthesiser and Oscillator	Ball	Pad Type	Description
XTAL_IN	K3	Analogue	For crystal or external clock input
XTAL_OUT	J3	Analogue	Drive for crystal
LOOP_FILTER	H2	No pad	Do not connect

PCM Interface	Ball	Pad Type	Description
PCM_OUT	G8	CMOS output, tri-state with weak internal pull-down	Synchronous data output
PCM_IN	G9	CMOS input, with weak internal pull-down	Synchronous data input
PCM_SYNC	G10	Bi-directional with weak internal pull-down	Synchronous data sync
PCM_CLK	H10	Bi-directional with weak internal pull-down	Synchronous data clock

USB and UART	Ball	Pad Type	Description
UART_TX	J10	CMOS output, tri-state with weak internal pull-up	UART data output active high
UART_RX	H9	CMOS input with weak internal pull-down	UART data input active high
UART_RTS	H7	CMOS output, tri-state with weak internal pull-up	UART request to send active low
UART_CTS	H8	CMOS input with weak internal pull-down	UART clear to send active low
USB_DP	J8	Bi-directional	USB data plus with selectable internal 1.5k Ω pull-up resistor
USB_DN	K8	Bi-directional	USB data minus

Test and Debug	Ball	Pad Type	Description
RESET	C7	CMOS input with weak internal pull-down	Reset if high. Input debounced, so must be high for >5ms to cause a reset
RESET_B	D8	CMOS input with weak internal pull-up	Reset if low. Input debounced, so must be low for >5ms to cause a reset
SPI_CSB	C9	CMOS input with weak internal pull-up	Chip select for Serial Peripheral Interface, active low
SPI_CLK	C10	CMOS input with weak internal-pull-down	Serial Peripheral Interface clock
SPI_MOSI	C8	CMOS input with weak internal pull-down	Serial Peripheral Interface data input
SPI_MISO	B9	CMOS output, tri-state with weak internal pull-down	Serial Peripheral Interface data output
TEST_EN	C6	CMOS input with strong internal pull-down	For test purposes only (leave unconnected)
FLASH_EN	B8	No pad	Pull high to VDD_MEM for compatibility with flash devices

PIO Port	Ball	Pad Type	Description
PIO[2]	B3	Bi-directional with programmable strength internal pull-up/down	Programmable input/output line
PIO[3]	B4	Bi-directional with programmable strength internal pull-up/down	Programmable input/output line
PIO[4]	E8	Bi-directional with programmable strength internal pull-up/down	Programmable input/output line
PIO[5]	F8	Bi-directional with programmable strength internal pull-up/down	Programmable input/output line
PIO[6]	F10	Bi-directional with programmable strength internal pull-up/down	Programmable input/output line
PIO[7]	F9	Bi-directional with programmable strength internal pull-up/down	Programmable input/output line
PIO[8]	C5	Bi-directional with programmable strength internal pull-up/down	Programmable input/output line
PIO[9]	C3	Bi-directional with programmable strength internal pull-up/down	Programmable input/output line
PIO[10]	C4	Bi-directional with programmable strength internal pull-up/down	Programmable input/output line
PIO[11]	E3	Bi-directional with programmable strength internal pull-up/down	Programmable input/output line
AIO[0]	H4	Bi-directional	Programmable input/output line
AIO[1]	H5	Bi-directional	Programmable input/output line
AIO[2]	J5	Bi-directional	Programmable input/output line

Power Supplies and Control	Ball	Pad Type	Description
VREG_IN	K6	Regulator Input	Linear regulator voltage input ⁽¹⁾
VREG_EN	K5	CMOS input	High or not connected to enable regulator. VSS to disable regulator ⁽¹⁾
VDD_USB	K9	VDD	Positive supply for UART/USB and AIO ports
VDD_PIO	A3	VDD	Positive supply for PIO and AUX DAC ⁽²⁾
VDD_PADS	D10	VDD	Positive supply for all other digital input/output ports ⁽³⁾
VDD_PRG	G3	VDD	Positive supply for battery backed memory
VDD_MEM	A6, A7, A9, H6, J6, K7	VDD	Not connected on ROM device
VDD_CORE	E10	VDD	Positive supply for internal digital circuitry
VDD_RADIO	C1, C2	VDD	Positive supply for RF circuitry
VDD_VCO	H1	VDD	Positive supply for VCO and synthesiser circuitry
VDD_ANA	K4	VDD/Regulator output	Positive supply for analogue circuitry and 1.8V regulated output
VSS_PADS	A1, A2, D9, J9, K10	VSS	Ground connections for input/output
VSS_MEM	A10, B5, B7, B10, J7	VSS	Ground connections for program memory and AIO ports
VSS_CORE	E9	VSS	Ground connection for internal digital circuitry
VSS_RADIO	D2, E2, F2	VSS	Ground connections for RF circuitry
VSS_VCO	G1, G2	VSS	Ground connections for VCO and synthesiser
VSS_ANA	J2, J4, K2	VSS	Ground connections for analogue circuitry
VSS	F3	VSS	Ground connection for internal package shield

Unconnected Terminals	Ball	Description
	A4, A5, A8, B6, H3, J1, K1	Leave unconnected

Notes:

- (1) To enable the regulator the VREG_EN pin needs to be either pulled high or left unconnected. This keeps compatibility with BlueCore2-ROM as the corresponding pin on BlueCore2-ROM was designated as a not connect pin. In this situation the BlueCore3-ROM regulator is permanently on replicating the BlueCore2-ROM that has no regulator enable pin.
- (2) Positive supply for PIO[3:0] and PIO[11:8]
- (3) Positive supply for SPI/PCM ports and PIO[7:4]

3 6.5 x 6.5mm Package Information

3.1 BlueCore3-ROM Flash Pinout Diagram

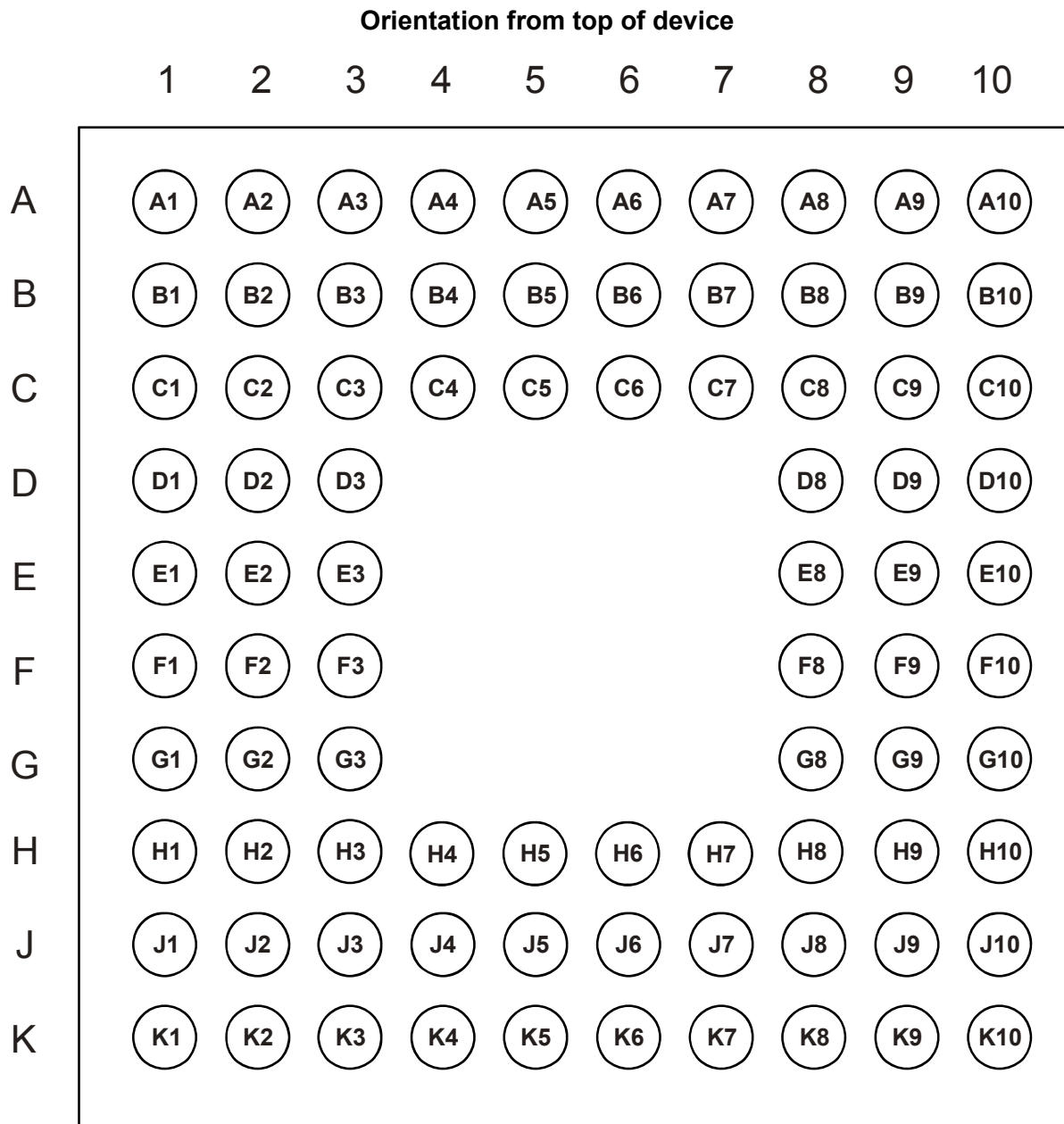

Figure 3.1: BlueCore3-ROM Flash 6.5 x 6.5mm Packages (BC31A159A-ES-ITK)

3.2 Device Terminal Functions

Radio	Ball	Pad Type	Description
RF_IN	D1	Analogue	Single-ended receiver input
PIO[0]/RXEN	B1	Bi-directional with programmable strength internal pull-up/down	Control output for external TX/RX switch (if fitted)
PIO[1]/TXEN	B2	Bi-directional with programmable strength internal pull-up/down	Control output for external PA (if fitted)
TX_A	F1	Analogue	Transmitter output/switched receiver input
TX_B	E1	Analogue	Complement of TX_A
AUX_DAC	D3	Analogue	Voltage DAC output

Synthesiser and Oscillator	Ball	Pad Type	Description
XTAL_IN	K3	Analogue	For crystal or external clock input
XTAL_OUT	J3	Analogue	Drive for crystal
LOOP_FILTER	H2	No pad	Do not connect

PCM Interface	Ball	Pad Type	Description
PCM_OUT	G8	CMOS output, tri-state with weak internal pull-down	Synchronous data output
PCM_IN	G9	CMOS input, with weak internal pull-down	Synchronous data input
PCM_SYNC	G10	Bi-directional with weak internal pull-down	Synchronous data sync
PCM_CLK	H10	Bi-directional with weak internal pull-down	Synchronous data clock

USB and UART	Ball	Pad Type	Description
UART_TX	J10	CMOS output, tri-state with weak internal pull-up	UART data output active high
UART_RX	H9	CMOS input with weak internal pull-down	UART data input active high
UART_RTS	H7	CMOS output, tri-state with weak internal pull-up	UART request to send active low
UART_CTS	H8	CMOS input with weak internal pull-down	UART clear to send active low
USB_DP	J8	Bi-directional	USB data plus with selectable internal 1.5k Ω pull-up resistor
USB_DN	K8	Bi-directional	USB data minus

Test and Debug	Ball	Pad Type	Description
RESET	C7	CMOS input with weak internal pull-down	Reset if high. Input debounced, so must be high for >5ms to cause a reset
RESET_B	D8	CMOS input with weak internal pull-up	Reset if low. Input debounced, so must be low for >5ms to cause a reset
SPI_CSB	C9	CMOS input with weak internal pull-up	Chip select for Serial Peripheral Interface, active low
SPI_CLK	C10	CMOS input with weak internal-pull-down	Serial Peripheral Interface clock
SPI_MOSI	C8	CMOS input with weak internal pull-down	Serial Peripheral Interface data input
SPI_MISO	B9	CMOS output, tri-state with weak internal pull-down	Serial Peripheral Interface data output
TEST_EN	C6	CMOS input with strong internal pull-down	For test purposes only (leave unconnected)
FLASH_EN	B8	No pad	Pull high to VDD_MEM for compatibility with flash devices

PIO Port	Ball	Pad Type	Description
PIO[2]	B3	Bi-directional with programmable strength internal pull-up/down	Programmable input/output line
PIO[3]	B4	Bi-directional with programmable strength internal pull-up/down	Programmable input/output line
PIO[4]	E8	Bi-directional with programmable strength internal pull-up/down	Programmable input/output line
PIO[5]	F8	Bi-directional with programmable strength internal pull-up/down	Programmable input/output line
PIO[6]	F10	Bi-directional with programmable strength internal pull-up/down	Programmable input/output line
PIO[7]	F9	Bi-directional with programmable strength internal pull-up/down	Programmable input/output line
PIO[8]	C5	Bi-directional with programmable strength internal pull-up/down	Programmable input/output line
PIO[9]	C3	Bi-directional with programmable strength internal pull-up/down	Programmable input/output line
PIO[10]	C4	Bi-directional with programmable strength internal pull-up/down	Programmable input/output line
PIO[11]	E3	Bi-directional with programmable strength internal pull-up/down	Programmable input/output line
AIO[0]	H4	Bi-directional	Programmable input/output line
AIO[1]	H5	Bi-directional	Programmable input/output line
AIO[2]	J5	Bi-directional	Programmable input/output line

Power Supplies and Control	Ball	Pad Type	Description
VREG_IN	K6	Regulator Input	Linear regulator voltage input
VREG_EN	K5	CMOS input	This pin must be pulled high externally to enable the device ⁽¹⁾
VDD_USB	K9	VDD	Positive supply for UART/USB and AIO ports
VDD_PIO	A3	VDD	Positive supply for PIO and AUX DAC ⁽²⁾
VDD_PADS	D10	VDD	Positive supply for all other digital input/output ports ⁽³⁾
VDD_PRG	G3	VDD	Positive supply for battery backed memory
VDD_MEM	A6, A7, A9, H6, J6, K7	VDD	Not connected on ROM device
VDD_CORE	E10	VDD	Positive supply for internal digital circuitry
VDD_RADIO	C1, C2	VDD	Positive supply for RF circuitry
VDD_VCO	H1	VDD	Positive supply for VCO and synthesiser circuitry
VDD_ANA	K4	VDD/Regulator output	Positive supply for analogue circuitry and 1.8V regulated output
VSS_PADS	A1, A2, D9, J9, K10	VSS	Ground connections for input/output
VSS_MEM	A10, B5, B7, B10, J7	VSS	Ground connections for program memory and AIO ports
VSS_CORE	E9	VSS	Ground connection for internal digital circuitry
VSS_RADIO	D2, E2, F2	VSS	Ground connections for RF circuitry
VSS_VCO	G1, G2	VSS	Ground connections for VCO and synthesiser
VSS_ANA	J2, J4, K2	VSS	Ground connections for analogue circuitry
VSS	F3	VSS	Ground connection for internal package shield

Unconnected Terminals	Ball	Description
	A4, A5, A8, B6, H3, J1, K1	Leave unconnected

Notes:

- (1) If BlueCore3-ROM Flash is being used as a development part to replicate BlueCore3-ROM functionality then VREG_EN must be pulled high externally to replicate the ROM devices functionality. If VREG_EN is not being used then connect pin VREG_EN to VREG_IN.
- (2) Positive supply for PIO[3:0] and PIO[11:8]
- (3) Positive supply for SPI/PCM ports and PIO[7:4]

4 Electrical Characteristics

Absolute Maximum Ratings		
Rating	Minimum	Maximum
Storage Temperature	-40°C	150°C
Supply Voltage: VDD_RADIO, VDD_VCO, VDD_ANA, VDD_CORE, VDD_MEM, VDD_PRG	-0.40V	2.20V
Supply Voltage: VDD_PADS, VDD_PIO, VDD_USB	-0.40V	3.70V
Supply Voltage: VREG_IN	-0.40V	5.60V
Other Terminal Voltages	VSS-0.4V	VDD+0.4V

Recommended Operating Conditions		
Operating Condition	Minimum	Maximum
Operating Temperature Range	-40°C	105°C
Guaranteed RF performance range	-40°C	105°C
Supply Voltage: VDD_RADIO, VDD_VCO, VDD_ANA, VDD_CORE, VDD_MEM, VDD_PRG	1.70V	1.90V
Supply Voltage: VDD_PADS, VDD_PIO, VDD_USB	1.70V	3.60V
Supply Voltage: VREG_IN	2.20V	4.20V ⁽¹⁾

Note:

- ⁽¹⁾ The device will operate without damage with VREG_IN as high as 5.6V, however the RF performance is not guaranteed above 4.20V.

Input/Output Terminal Characteristics				
Linear Regulator	Minimum	Typical	Maximum	Unit
Normal Operation				
Output Voltage (Iload = 70mA / Vreg_IN = 3.0V)	1.70	1.78	1.85	V
Temperature Coefficient	-250	-	250	ppm/C
Output Noise ⁽¹⁾⁽²⁾	-	-	1	mV rms
Load Regulation (Iload < 100 mA)	-	-	50	mV/A
Settling Time ⁽¹⁾⁽³⁾	-	-	50	μs
Maximum Output Current	70	-	-	mA
Minimum Load Current	5	-	-	μA
Input Voltage	-	-	4.2 ⁽⁶⁾	V
Dropout Voltage (Iload = 70 mA)	-	-	350	mV
Quiescent Current (excluding load, Iload < 1mA)	25	35	50	μA
Low Power Mode⁽⁴⁾				
Quiescent Current (excluding load, Iload < 100μA)	4	7	10	μA
Disabled Mode⁽⁵⁾				
Quiescent Current	1.5	2.5	3.5	μA

Notes:

- (1) Regulator output connected to 47nF pure and 4.7μF 2.2Ω ESR capacitors
- (2) Frequency range 100Hz to 100kHz
- (3) 1mA to 70mA pulsed load
- (4) Low power mode is entered and exited automatically when the chip enters/leaves Deep Sleep mode
- (5) Regulator is disabled when VREG_EN is pulled low. It is also disabled when VREG_IN is either open circuit or driven to the same voltage as VDD_ANA.
- (6) Operation up to 5.6V is permissible without damage and without the output voltage rising sufficiently to damage the rest of BlueCore3, but output regulation and other specifications are no longer guaranteed at input voltages in excess of 4.2V.

Input/Output Terminal Characteristics (Continued)					
Digital Terminals		Minimum	Typical	Maximum	Unit
Input Voltage Levels					
V _{IL} input logic level low	(VDD=3.0V)	-0.4	-	0.8	V
	(VDD=1.8V)	-0.4	-	0.4	V
V _{IH} input logic level high		0.7VDD	-	VDD+0.4	V
Output Voltage Levels					
V _{OL} output logic level low, (I _o = 4.0mA), VDD=3.0V		-	-	0.2	V
V _{OL} output logic level low, (I _o = 4.0mA), VDD=1.8V		-	-	0.4	V
V _{OH} output logic level high, (I _o = -4.0mA), VDD=3.0V		VDD-0.2	-	-	V
V _{OH} output logic level high, (I _o = -4.0mA), VDD=1.8V		VDD-0.4	-	-	V
Input and Tri-State Current with:					
Strong pull-up		-100	-20	-10	μA
Strong pull-down		10	20	100	μA
Weak pull-up		-5	-1	-0.5	μA
Weak pull-down		0.5	1	5	μA
I/O pad leakage current		-1	0	1	μA
C _i Input Capacitance		1.0	-	5.0	pF

USB Terminals		Minimum	Typical	Maximum	Unit
Input threshold					
V _{IL} input logic level low		-	-	0.3VDD_USB	V
V _{IH} input logic level high		0.57VDD_USB	-	-	V
Input leakage current					
VSS_USB < V _{IN} < VDD_USB ⁽¹⁾		-1	-	1	μA
C _i Input capacitance		2.5	-	10.0	pF
Output Voltage levels					
To correctly terminated USB Cable					
V _{OL} output logic level low		0.0	-	0.2	V
V _{OH} output logic level high		2.8	-	VDD_USB	V

Input/Output Terminal Characteristics (Continued)					
Auxiliary ADC	Minimum	Typical	Maximum	Unit	
Resolution	-	-	8	Bits	
Input voltage range (LSB size = VDD_ANA/255)	0	-	VDD_ANA	V	
Accuracy (Guaranteed monotonic)	INL	-1	-	1	LSB
	DNL	0	-	1	LSB
Offset	-1	-	1	LSB	
Gain Error	-0.8	-	0.8	%	
Input Bandwidth	-	100	-	kHz	
Conversion time	-	2.5	-	μs	
Sample rate ⁽²⁾	-	-	700	Samples/s	

Input/Output Terminal Characteristics (Continued)				
Auxiliary DAC	Minimum	Typical	Maximum	Unit
Resolution	-	-	8	Bits
Average output step size ⁽²⁾	12.5	14.2	16.5	mV
Output Voltage		Monotonic ⁽²⁾		
Voltage range (I _o =0mA)	VSS_PIO	-	VDD_PIO	V
Current range	-10.0	-	+0.1	mA
Minimum output voltage (I _o =100μA)	0.0	-	0.2	V
Maximum output voltage (I _o =10mA)	VDD_PIO-0.3	-	VDD_PIO	V
High Impedance leakage current	-1	-	1	μA
Offset	-120	-	120	mV
Integral non-linearity ⁽³⁾	-1.5	-	1.5	LSB
Starting time (50pF load)	-	-	10	μs
Settling time (50pF load)	-	-	5	μs

Crystal Oscillator	Minimum	Typical	Maximum	Unit
Crystal frequency ⁽⁴⁾	8.0	-	32.0	MHz
Digital trim range ⁽⁵⁾	5.0	6.2	8.0	pF
Trim step size ⁽⁵⁾	-	0.1	-	pF
Transconductance	2.0	-	-	mS
Negative resistance ⁽⁶⁾	870	1500	2400	Ω
External Clock				
Input frequency ⁽⁷⁾	8.0	-	40.0	MHz
Clock input level ⁽⁸⁾	0.4	-	VDD_ANA	V pk-pk
Allowable jitter	-	-	15	ps rms
XTAL_IN input impedance	-	≥10	-	kΩ
XTAL_IN input capacitance	-	≤4	-	pF

Input/Output Terminal Characteristics (Continued)				
Power-on reset	Minimum	Typical	Maximum	Unit
VDD_CORE falling threshold	1.40	1.50	1.60	V
VDD_CORE rising threshold	1.50	1.60	1.70	V
Hysteresis	0.05	0.10	0.15	V

Notes:

VDD_CORE, VDD_RADIO, VDD_VCO, VDD_ANA, VDD_BAL and VDD_MEM are at 1.8V unless shown otherwise

VDD_PADS, VDD_PIO and VDD_USB are at 3.0V unless shown otherwise

The same setting of the digital trim is applied to both XTAL_IN and XTAL_OUT

Current drawn into a pin is defined as positive; current supplied out of a pin is defined as negative

- (1) Internal USB pull-up disabled
- (2) Access of ADC is through VM function and therefore sample rate given is achieved as part of this function
- (3) Specified for an output voltage between 0.2V and VDD_PIO -0.2V
- (4) Integer multiple of 250kHz
- (5) The difference between the internal capacitance at minimum and maximum settings of the internal digital trim
- (6) XTAL frequency = 16MHz; XTAL C0 = 0.75pF; XTAL load capacitance = 8.5pF
- (7) Clock input can be any frequency between 8 and 40MHz in steps of 250kHz + CDMA/3G TCXO frequencies of 15.36, 16.2, 16.8, 19.2, 19.44, 19.68, 19.8 and 38.4MHz
- (8) Clock input can either be sinusoidal or square wave if the peaks of the signal are below VSS_ANA or above VDD_ANA a DC blocking capacitor is required between the signal and XTAL_IN

5 Radio Characteristics

Important Notes

BlueCore3-ROM meets the Bluetooth specification v1.2 when used in a suitable application circuit between -40°C and +105°C.

Tx output is guaranteed to be unconditionally stable over the guaranteed temperature range.

The radio characteristics for BlueCore3-ROM Flash are not stated as this device is for software prototyping only.

5.1 Temperature +20°C

5.1.1 Transmitter

Radio Characteristics VDD = 1.8V Temperature = +20°C					
	Min	Typ	Max	Bluetooth Specification	Unit
Maximum RF transmit power ⁽¹⁾⁽²⁾	-	6.0	-	-6 to +4 ⁽³⁾	dBm
Variation in RF power over temperature range with compensation enabled (\pm) ⁽⁴⁾	-	0.5	-	-	dB
Variation in RF power over temperature range with compensation disabled (\pm) ⁽⁴⁾	-	3	-	-	dB
RF power control range	-	35	-	≥ 16	dB
RF power range control resolution ⁽⁵⁾	-	0.5	-	-	dB
20dB bandwidth for modulated carrier	-	790	-	≤ 1000	kHz
Adjacent channel transmit power $F=F_0 \pm 2\text{MHz}$ ⁽⁶⁾⁽⁷⁾	-	-35	-	≤ -20	dBm
Adjacent channel transmit power $F=F_0 \pm 3\text{MHz}$ ⁽⁶⁾⁽⁷⁾	-	-45	-	≤ -40	dBm
Adjacent channel transmit power $F=F_0 > \pm 3\text{MHz}$ ⁽⁶⁾⁽⁷⁾	-	-55	-	≤ -40	dBm
$\Delta f_{1\text{avg}}$ "Maximum Modulation"	-	165	-	$140 < \Delta f_{1\text{avg}} < 175$	kHz
$\Delta f_{2\text{max}}$ "Minimum Modulation"	-	135	-	115	kHz
$\Delta f_{2\text{avg}} / \Delta f_{1\text{avg}}$	-	0.9	-	≥ 0.80	-
Initial carrier frequency tolerance	-	10	-	± 75	kHz
Drift Rate	-	8	-	≤ 20	kHz/50 μ s
Drift (single slot packet)	-	7	-	≤ 25	kHz
Drift (five slot packet)	-	8	-	≤ 40	kHz
2 nd Harmonic Content	-	-55	-	≤ 30	dBm
3 rd Harmonic Content	-	-60	-	≤ 30	dBm

Notes:

- (1) BlueCore3-ROM firmware maintains the transmit power within the Bluetooth specification v1.2 limits
- (2) Measurement made using a PSKEY_LC_MAX_TX_POWER setting corresponds to a PSKEY_LC_POWER_TABLE power table entry of 63
- (3) Class 2 RF transmit power range, Bluetooth specification v1.2
- (4) To some extent these parameters are dependent on the matching circuit used, and its behaviour over temperature. Therefore these parameters may be beyond CSR's direct control
- (5) Resolution guaranteed over the range -5dB to -25dB relative to maximum power for Tx Level >20.
- (6) Measured at $F_0 = 2441\text{MHz}$

- (7) Up to three exceptions are allowed in v1.2 of the Bluetooth specification. BlueCore3-ROM is guaranteed to meet the ACP performance as specified by the Bluetooth specification v1.2.

Radio Characteristics VDD = 1.8V Temperature = +20°C (Continued)						
	Frequency (GHz)	Min	Typ	Max	Cellular Band	Unit
Emitted power in cellular bands measured at chip terminals Output power ≤4dBm	0.869 – 0.894 ⁽¹⁾	-	-134	-	GSM 850	dBm
	0.869 – 0.894 ⁽²⁾	-	-133	-	CDMA 850	
	0.925 – 0.960 ⁽¹⁾	-	-136	-	GSM 900	
	1.570 – 1.580 ⁽³⁾	-	-140	-	GPS	
	1.805 – 1.880 ⁽¹⁾	-	-141	-	GSM 1800 / DCS 1800	
	1.930 – 1.990 ⁽⁴⁾	-	-135	-	PCS 1900	
	1.930 – 1.990 ⁽¹⁾	-	-135	-	GSM 1900	
	1.930 – 1.990 ⁽¹⁾	-	-134	-	CDMA 1900	
	2.110 – 2.170 ⁽²⁾	-	-131	-	W-CDMA 2000	
	2.110 – 2.170 ⁽⁵⁾	-	-135	-	W-CDMA 2000	

Notes:

- (1) Integrated in 200kHz bandwidth.
- (2) Integrated in 1.2MHz bandwidth.
- (3) Integrated in 1MHz bandwidth.
- (4) Integrated in 30kHz bandwidth.
- (5) Integrated in 5MHz bandwidth.

5.1.2 Receiver

Radio Characteristics VDD = 1.8V Temperature = +20°C						
	Frequency (GHz)	Min	Typ	Max	Bluetooth Specification	Unit
Sensitivity at 0.1% BER for all packet types	2.402	-	-84	-	≤-70	dBm
	2.441	-	-85	-		
	2.480	-	-83	-		
Maximum received signal at 0.1% BER		-	3	-	≥-20	dBm
	Frequency (MHz)	Min	Typ	Max	Bluetooth Specification	Unit
Continuous power required to block Bluetooth reception (for sensitivity of -67dBm with 0.1% BER) measured at chip terminals	30 – 2000	-	TBA	-	-10	dBm
	2000 – 2399	-	TBA	-	-27	
	2498 – 3000	-	TBA	-	-27	
	3000 – 12750	-	TBA	-	-10	
C/I co-channel		-	6	-	≤11	dB
Adjacent channel selectivity C/I F = F ₀ + 1MHz ⁽¹⁾⁽²⁾		-	-4	-	≤0	dB
Adjacent channel selectivity C/I F = F ₀ - 1MHz ⁽¹⁾⁽²⁾		-	-4	-	≤0	dB
Adjacent channel selectivity C/I F = F ₀ + 2MHz ⁽¹⁾⁽²⁾		-	-38	-	≤-30	dB
Adjacent channel selectivity C/I F = F ₀ - 2MHz ⁽¹⁾⁽²⁾		-	-23	-	≤-20	dB
Adjacent channel selectivity C/I F ≥ F ₀ + 3MHz ⁽¹⁾⁽²⁾		-	-45	-	≤-40	dB
Adjacent channel selectivity C/I F ≤ F ₀ - 5MHz ⁽¹⁾⁽²⁾		-	-45	-	≤-40	dB
Adjacent channel selectivity C/I F = F _{image} ⁽¹⁾⁽²⁾		-	-22	-	≤-9	dB
Maximum level of intermodulation interferers ⁽³⁾		-	-30	-	≥-39	dBm
Spurious output level ⁽⁴⁾		-	-140	-	-	dBm/Hz

Notes:

- (1) Up to five exceptions are allowed in v1.2 of the Bluetooth specification. BlueCore3-ROM is guaranteed to meet the C/I performance as specified by the Bluetooth specification v1.2.
- (2) Measured at F₀ = 2405MHz, 2441MHz, 2477MHz
- (3) Measured at f1-f2 = 5MHz. Measurement is performed in accordance with Bluetooth RF test RCV/CA/05/c. i.e. wanted signal at -64dBm
- (4) Integrated in 100kHz bandwidth. Actual figure is typically below -140dBm/Hz except for peaks at multiples of receive frequency/3.

Radio Characteristics VDD = 1.8V Temperature = +20°C (Continued)						
	Frequency (GHz)	Min	Typ	Max	Cellular Band	Unit
Continuous power in cellular bands required to block Bluetooth reception (for sensitivity of -67dBm with 0.1% BER) measured at chip terminals	0.824 – 0.849 ⁽¹⁾	-	+4	-	GSM 850	dBm
	0.824 – 0.849	-	+5	-	CDMA	
	0.880 – 0.915	-	+8	-	GSM 900	
	1.710 – 1.785	-	>+5	-	GSM 1800 / DCS 1800	
	1.850 – 1.910	-	>+3	-	GSM 1900 / PCS 1900	
	1.850 – 1.910	-	>+3	-	CDMA 1900	
	1.920 – 1.980	-	>+4	-	W-CDMA 2000	
Continuous power in cellular bands required to block Bluetooth reception (for sensitivity of -72dBm with 0.1% BER) measured at chip terminals	0.824 – 0.849 ⁽¹⁾	-	+3	-	GSM 850	dBm
	0.824 – 0.849	-	+3	-	CDMA	
	0.880 – 0.915	-	+8	-	GSM 900	
	1.710 – 1.785	-	>+5	-	GSM 1800 / DCS 1800	
	1.850 – 1.910	-	>+3	-	GSM 1900 / PCS 1900	
	1.850 – 1.910	-	>+3	-	CDMA 1900	
	1.920 – 1.980	-	>+4	-	W-CDMA 2000	

Note:
⁽¹⁾ $|3f_{\text{Blocking}} - f_{\text{Bluetooth}}| > 10\text{MHz}$

5.2 Temperature -40°C

5.2.1 Transmitter

Radio Characteristics VDD = 1.8V Temperature = -40°C					
	Min	Typ	Max	Bluetooth Specification	Unit
Maximum RF transmit power ⁽¹⁾	-	8	-	-6 to +4 ⁽²⁾	dBm
RF power control range	-	35	-	≥16	dB
RF power range control resolution	-	0.5	-	-	dB
20dB bandwidth for modulated carrier	-	790	-	≤1000	kHz
Adjacent channel transmit power $F = F_0 \pm 2\text{MHz}$ ⁽⁴⁾⁽⁵⁾	-	-35	-	≤-20	dBm
Adjacent channel transmit power $F = F_0 \pm 3\text{MHz}$ ⁽⁴⁾⁽⁵⁾	-	-45	-	≤-40	dBm
Adjacent channel transmit power $F = F_0 > \pm 3\text{MHz}$ ⁽⁴⁾⁽⁵⁾	-	-55	-	≤-40	dBm
$\Delta f_{1\text{avg}}$ "Maximum Modulation"	-	165	-	$140 < \Delta f_{1\text{avg}} < 175$	kHz
$\Delta f_{2\text{max}}$ "Minimum Modulation"	-	138	-	115	kHz
$\Delta f_{2\text{avg}} / \Delta f_{1\text{avg}}$	-	0.9	-	≥0.80	-
Initial carrier frequency tolerance	-	10	-	±75	kHz
Drift Rate	-	8	-	≤20	kHz/50μs
Drift (single slot packet)	-	8	-	≤25	kHz
Drift (five slot packet)	-	9	-	≤40	kHz

Notes:

- (1) BlueCore3-ROM firmware maintains the transmit power to be within the Bluetooth specification v1.2 limits
- (2) Class 2 RF transmit power range, Bluetooth specification v1.2
- (3) To some extent these parameters are dependent on the matching circuit used, and its behaviour over temperature. Therefore these parameters may be beyond CSR's direct control
- (4) Measured at $F_0 = 2441\text{MHz}$
- (5) Up to three exceptions are allowed in v1.2 of the Bluetooth specification

5.2.2 Receiver

Radio Characteristics VDD = 1.8V Temperature = -40°C						
	Frequency (GHz)	Min	Typ	Max	Bluetooth Specification	Unit
Sensitivity at 0.1% BER for all packet types	2.402	-	-87	-	≤-70	dBm
	2.441	-	-88	-		
	2.480	-	-84	-		
Maximum received signal at 0.1% BER		-	1	-	≥-20	dBm

5.3 Temperature -30°C

5.3.1 Transmitter

Radio Characteristics VDD = 1.8V Temperature = -30°C						
	Frequency (GHz)	Min	Typ	Max	Cellular Band	Unit
Emitted power in cellular bands measured at chip terminals Output power ≤4dBm	0.869 – 0.894 ⁽¹⁾	-	-134	-	GSM 850	dBm
	0.869 – 0.894 ⁽²⁾	-	-133	-	CDMA 850	
	0.925 – 0.960 ⁽¹⁾	-	-137	-	GSM 900	
	1.570 – 1.580 ⁽³⁾	-	-140	-	GPS	
	1.805 – 1.880 ⁽¹⁾	-	-139	-	GSM 1800 / DCS 1800	
	1.930 – 1.990 ⁽⁴⁾	-	-135	-	PCS 1900	
	1.930 – 1.990 ⁽¹⁾	-	-135	-	GSM 1900	
	1.930 – 1.990 ⁽¹⁾	-	-136	-	CDMA 1900	
	2.110 – 2.170 ⁽²⁾	-	-131	-	W-CDMA 2000	
2.110 – 2.170 ⁽⁵⁾	-	-135	-	W-CDMA 2000		

Notes:

- (1) Integrated in 200kHz bandwidth.
- (2) Integrated in 1.2MHz bandwidth.
- (3) Integrated in 1MHz bandwidth.
- (4) Integrated in 30kHz bandwidth.
- (5) Integrated in 5MHz bandwidth.

5.3.2 Receiver

Radio Characteristics VDD = 1.8V Temperature = -30°C						
	Frequency (GHz)	Min	Typ	Max	Cellular Band	Unit
Continuous power in cellular bands required to block Bluetooth reception (for sensitivity of -67dBm with 0.1% BER) measured at chip terminals	0.824 – 0.849 ⁽¹⁾	-	+3	-	GSM 850	dBm
	0.824 – 0.849	-	+5	-	CDMA	
	0.880 – 0.915	-	+8	-	GSM 900	
	1.710 – 1.785	-	>+5	-	GSM 1800 / DCS 1800	
	1.850 – 1.910	-	>+3	-	GSM 1900 / PCS 1900	
	1.850 – 1.910	-	>+3	-	CDMA 1900	
	1.920 – 1.980	-	>+4	-	W-CDMA 2000	
Continuous power in cellular bands required to block Bluetooth reception (for sensitivity of -72dBm with 0.1% BER) measured at chip terminals	0.824 – 0.849 ⁽¹⁾	-	+1	-	GSM 850	dBm
	0.824 – 0.849	-	+3	-	CDMA	
	0.880 – 0.915	-	+7	-	GSM 900	
	1.710 – 1.785	-	>+5	-	GSM 1800 / DCS 1800	
	1.850 – 1.910	-	>+3	-	GSM 1900 / PCS 1900	
	1.850 – 1.910	-	>+3	-	CDMA 1900	
	1.920 – 1.980	-	>+4	-	W-CDMA 2000	

Note:

- (1) $|3f_{\text{Blocking}} - f_{\text{Bluetooth}}| > 10\text{MHz}$

5.4 Temperature -25°C

5.4.1 Transmitter

Radio Characteristics VDD = 1.8V Temperature = -25°C					
	Min	Typ	Max	Bluetooth Specification	Unit
Maximum RF transmit power ⁽¹⁾	-	7	-	-6 to +4 ⁽²⁾	dBm
RF power control range	-	35	-	≥16	dB
RF power range control resolution	-	0.5	-	-	dB
20dB bandwidth for modulated carrier	-	790	-	≤1000	kHz
Adjacent channel transmit power $F=F_0 \pm 2\text{MHz}$ ⁽⁴⁾⁽⁵⁾	-	-35	-	≤-20	dBm
Adjacent channel transmit power $F=F_0 \pm 3\text{MHz}$ ⁽⁴⁾⁽⁵⁾	-	-45	-	≤-40	dBm
Adjacent channel transmit power $F=F_0 > \pm 3\text{MHz}$ ⁽⁴⁾⁽⁵⁾	-	-55	-	≤-40	dBm
$\Delta f_{1\text{avg}}$ "Maximum Modulation"	-	165	-	$140 < \Delta f_{1\text{avg}} < 175$	kHz
$\Delta f_{2\text{max}}$ "Minimum Modulation"	-	138	-	115	kHz
$\Delta f_{2\text{avg}} / \Delta f_{1\text{avg}}$	-	0.9	-	≥0.80	-
Initial carrier frequency tolerance	-	10	-	±75	kHz
Drift Rate	-	8	-	≤20	kHz/50μs
Drift (single slot packet)	-	8	-	≤25	kHz
Drift (five slot packet)	-	9	-	≤40	kHz

Notes:

- (1) BlueCore3-ROM firmware maintains the transmit power to be within the Bluetooth specification v1.2 limits
- (2) Class 2 RF transmit power range, Bluetooth specification v1.2
- (3) To some extent these parameters are dependent on the matching circuit used, and its behaviour over temperature. Therefore these parameters may be beyond CSR's direct control
- (4) Measured at $F_0 = 2441\text{MHz}$
- (5) Up to three exceptions are allowed in v1.2 of the Bluetooth specification

5.4.2 Receiver

Radio Characteristics VDD = 1.8V Temperature = -25°C						
	Frequency (GHz)	Min	Typ	Max	Bluetooth Specification	Unit
Sensitivity at 0.1% BER for all packet types	2.402	-	-86	-	≤-70	dBm
	2.441	-	-87	-		
	2.480	-	-84	-		
Maximum received signal at 0.1% BER		-	1	-	≥-20	dBm

5.5 Temperature +85°C

5.5.1 Transmitter

Radio Characteristics VDD = 1.8V Temperature = +85°C					
	Min	Typ	Max	Bluetooth Specification	Unit
Maximum RF transmit power ⁽¹⁾	-	3	-	-6 to +4 ⁽²⁾	dBm
RF power control range	-	35	-	≥16	dB
RF power range control resolution	-	0.5	-	-	dB
20dB bandwidth for modulated carrier	-	790	-	≤1000	kHz
Adjacent channel transmit power $F=F_0 \pm 2\text{MHz}$ ⁽⁴⁾⁽⁵⁾	-	-40	-	≤-20	dBm
Adjacent channel transmit power $F=F_0 \pm 3\text{MHz}$ ⁽⁴⁾⁽⁵⁾	-	-50	-	≤-40	dBm
Adjacent channel transmit power $F=F_0 > \pm 3\text{MHz}$ ⁽⁴⁾⁽⁵⁾	-	-55	-	≤-40	dBm
$\Delta f_{1\text{avg}}$ "Maximum Modulation"	-	165	-	$140 < \Delta f_{1\text{avg}} < 175$	kHz
$\Delta f_{2\text{max}}$ "Minimum Modulation"	-	134	-	115	kHz
$\Delta f_{2\text{avg}} / \Delta f_{1\text{avg}}$	-	0.9	-	≥0.80	-
Initial carrier frequency tolerance	-	10	-	±75	kHz
Drift Rate	-	8	-	≤20	kHz/50μs
Drift (single slot packet)	-	9	-	≤25	kHz
Drift (five slot packet)	-	10	-	≤40	kHz

Notes:

- (1) BlueCore3-ROM firmware maintains the transmit power to be within the Bluetooth specification v1.2 limits
- (2) Class 2 RF transmit power range, Bluetooth specification v1.2
- (3) To some extent these parameters are dependent on the matching circuit used, and its behaviour over temperature. Therefore these parameters may be beyond CSR's direct control
- (4) Measured at $F_0 = 2441\text{MHz}$
- (5) Up to three exceptions are allowed in v1.2 of the Bluetooth specification

Radio Characteristics VDD = 1.8V Temperature = +85°C (Continued)						
	Frequency (GHz)	Min	Typ	Max	Cellular Band	Unit
Emitted power in cellular bands measured at chip terminals Output power ≤4dBm	0.869 – 0.894 ⁽¹⁾	-	-134	-	GSM 850	dBm
	0.869 – 0.894 ⁽²⁾	-	-133	-	CDMA 850	
	0.925 – 0.960 ⁽¹⁾	-	-136	-	GSM 900	
	1.570 – 1.580 ⁽³⁾	-	-140	-	GPS	
	1.805 – 1.880 ⁽¹⁾	-	-142	-	GSM 1800 / DCS 1800	
	1.930 – 1.990 ⁽⁴⁾	-	-135	-	PCS 1900	
	1.930 – 1.990 ⁽¹⁾	-	-135	-	GSM 1900	
	1.930 – 1.990 ⁽¹⁾	-	-135	-	CDMA 1900	
	2.110 – 2.170 ⁽²⁾	-	-131	-	W-CDMA 2000	
	2.110 – 2.170 ⁽⁵⁾	-	-135	-	W-CDMA 2000	

Notes:

- (1) Integrated in 200kHz bandwidth.
- (2) Integrated in 1.2MHz bandwidth.
- (3) Integrated in 1MHz bandwidth.
- (4) Integrated in 30kHz bandwidth.
- (5) Integrated in 5MHz bandwidth.

5.5.2 Receiver

Radio Characteristics VDD = 1.8V Temperature = +85°C						
	Frequency (GHz)	Min	Typ	Max	Bluetooth Specification	Unit
Sensitivity at 0.1% BER for all packet types	2.402	-	-82	-	≤-70	dBm
	2.441	-	-83	-		
	2.480	-	-81	-		
Maximum received signal at 0.1% BER		-	5	-	≥-20	dBm

Radio Characteristics VDD = 1.8V Temperature = +85°C						
	Frequency (GHz)	Min	Typ	Max	Cellular Band	Unit
Continuous power in cellular bands required to block Bluetooth reception (for sensitivity of -67dBm with 0.1% BER) measured at chip terminals	0.824 – 0.849 ⁽¹⁾	-	+5	-	GSM 850	dBm
	0.824 – 0.849	-	+6	-	CDMA	
	0.880 – 0.915	-	+8	-	GSM 900	
	1.710 – 1.785	-	>+5	-	GSM 1800 / DCS 1800	
	1.850 – 1.910	-	>+3	-	GSM 1900 / PCS 1900	
	1.850 – 1.910	-	>+3	-	CDMA 1900	
	1.920 – 1.980	-	>+4	-	W-CDMA 2000	
Continuous power in cellular bands required to block Bluetooth reception (for sensitivity of -72dBm with 0.1% BER) measured at chip terminals	0.824 – 0.849 ⁽¹⁾	-	>+6	-	GSM 850	dBm
	0.824 – 0.849	-	+4	-	CDMA	
	0.880 – 0.915	-	+6	-	GSM 900	
	1.710 – 1.785	-	>+5	-	GSM 1800 / DCS 1800	
	1.850 – 1.910	-	>+3	-	GSM 1900 / PCS 1900	
	1.850 – 1.910	-	>+3	-	CDMA 1900	
	1.920 – 1.980	-	>+4	-	W-CDMA 2000	

Note:

⁽¹⁾ $|3f_{\text{Blocking}} - f_{\text{Bluetooth}}| > 10\text{MHz}$

5.6 Temperature +105°C

5.6.1 Transmitter

Radio Characteristics VDD = 1.8V Temperature = +105°C					
	Min	Typ	Max	Bluetooth Specification	Unit
Maximum RF transmit power ⁽¹⁾	-	1.5	-	-6 to +4 ⁽²⁾	dBm
RF power control range	-	35	-	≥16	dB
RF power range control resolution	-	0.5	-	-	dB
20dB bandwidth for modulated carrier	-	810	-	≤1000	kHz
Adjacent channel transmit power $F=F_0 \pm 2\text{MHz}$ ⁽⁴⁾⁽⁵⁾	-	-45	-	≤-20	dBm
Adjacent channel transmit power $F=F_0 \pm 3\text{MHz}$ ⁽⁴⁾⁽⁵⁾	-	-50	-	≤-40	dBm
Adjacent channel transmit power $F=F_0 > \pm 3\text{MHz}$ ⁽⁴⁾⁽⁵⁾	-	-55	-	≤-40	dBm
$\Delta f_{1\text{avg}}$ "Maximum Modulation"	-	165	-	140 < $\Delta f_{1\text{avg}}$ < 175	kHz
$\Delta f_{2\text{max}}$ "Minimum Modulation"	-	130	-	115	kHz
$\Delta f_{2\text{avg}} / \Delta f_{1\text{avg}}$	-	0.9	-	≥0.80	-
Initial carrier frequency tolerance	-	10	-	±75	kHz
Drift Rate	-	9	-	≤20	kHz/50μs
Drift (single slot packet)	-	12	-	≤25	kHz
Drift (five slot packet)	-	14	-	≤40	kHz

Notes:

- (1) BlueCore3-ROM firmware maintains the transmit power to be within the Bluetooth specification v1.2 limits
- (2) Class 2 RF transmit power range, Bluetooth specification v1.2
- (3) To some extent these parameters are dependent on the matching circuit used, and its behaviour over temperature. Therefore these parameters may be beyond CSR's direct control
- (4) Measured at $F_0 = 2441\text{MHz}$
- (5) Up to three exceptions are allowed in v1.2 of the Bluetooth specification

5.6.2 Receiver

Radio Characteristics VDD = 1.8V Temperature = +105°C						
	Frequency (GHz)	Min	Typ	Max	Bluetooth Specification	Unit
Sensitivity at 0.1% BER for all packet types	2.402	-	-81	-78	≤-70	dBm
	2.441	-	-81	-78		
	2.480	-	-80	-77		
Maximum received signal at 0.1% BER		-	5	-	≥-20	dBm

5.7 Power Consumption

Operation Mode	Connection Type	UART Rate (kbps)	Average	Peak	Unit
Page scan	-	115.2	0.36	38.30	mA
Inquiry & page scan	-	115.2	0.66	38.67	mA
ACL data transfer No traffic	Master	115.2	6.36	14.43	mA
ACL data transfer With file transfer	Master	115.2	11.66	36.84	mA
ACL data transfer No traffic	Slave	115.2	13.68	19.23	mA
ACL data transfer With file transfer	Slave	115.2	16.99	35.70	mA
ACL data transfer 40ms sniff	Master	34.4	1.50	22.05	mA
ACL data transfer 1.28s sniff	Master	34.4	0.19	20.59	mA
SCO connection HV1	Master	34.4	33.80	35.70	mA
SCO connection HV3	Master	34.4	17.17	25.29	mA
SCO connection HV3 30ms sniff	Master	34.4	16.81	25.31	mA
ACL data transfer 40ms sniff	Slave	34.4	1.45	17.79	mA
ACL data transfer 1.28s sniff	Slave	34.4	0.24	28.00	mA
SCO connection HV1	Slave	34.4	33.82	35.73	mA
SCO connection HV3	Slave	34.4	20.79	29.00	mA
SCO connection HV3 30ms sniff	Slave	34.4	16.73	26.06	mA
Parked 1.28s beacon	Slave	34.4	0.18	26.26	mA
Standby Host connection	-	34.4	0.03	4.62	mA
Reset (RESETB low)	-	-	42	TBA	µA

Note:

Firmware used: 17.11.

6 Device Diagrams

6.1 BlueCore3-ROM

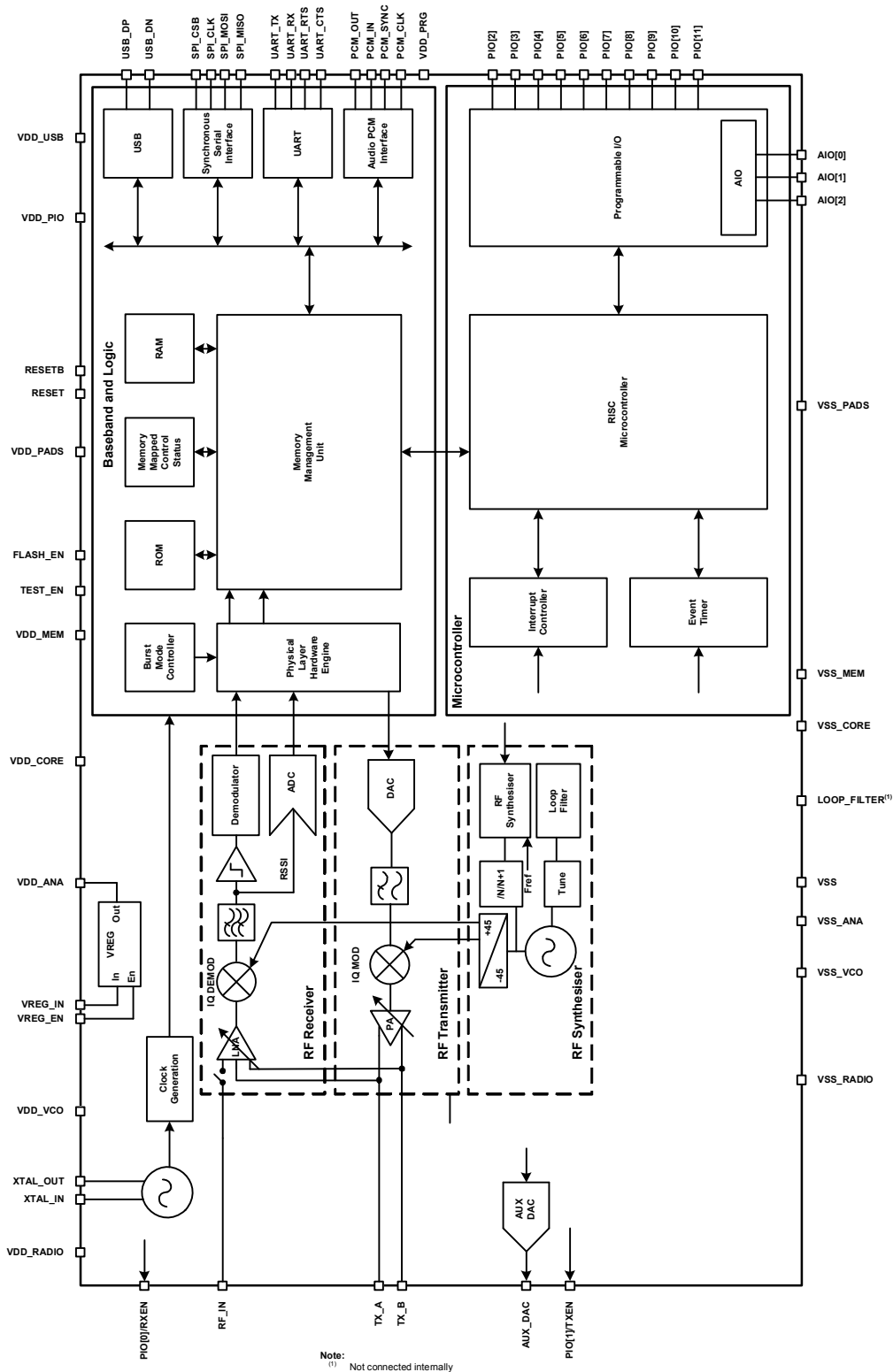

Figure 6.1: BlueCore3-ROM Device Diagram for 6 x 6mm VFBGA Packages

6.2 BlueCore3-ROM Flash

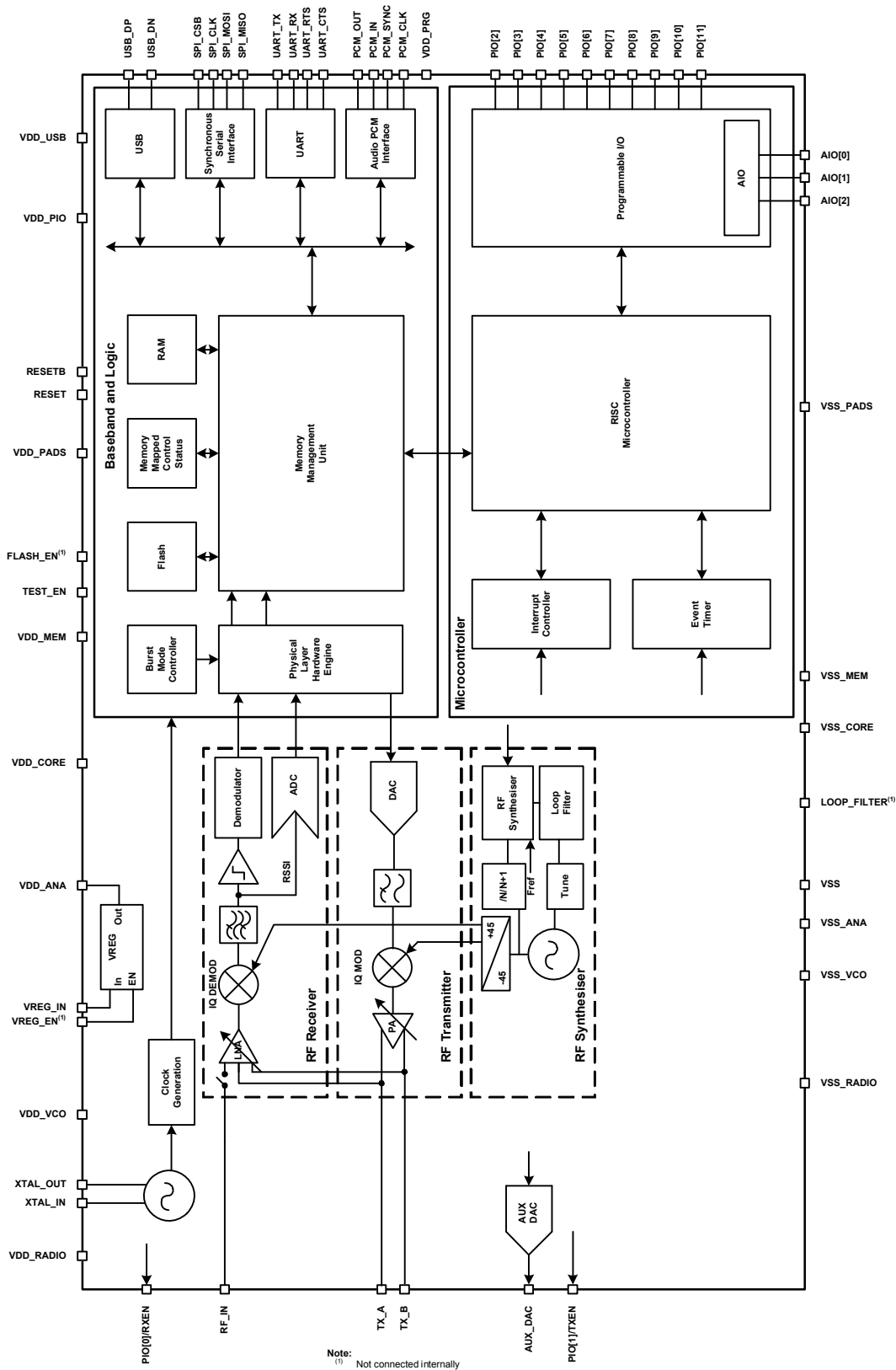

Figure 6.2: BlueCore3-ROM Flash Device Diagram for 6.5 x 6.5mm TFBGA Packages

7 Description of Functional Blocks

7.1 RF Receiver

The receiver features a near-zero Intermediate Frequency (IF) architecture that allows the channel filters to be integrated on to the die. Sufficient out-of-band blocking specification at the Low Noise Amplifier (LNA) input allows the radio to be used in close proximity to Global System for Mobile Communications (GSM) and Wideband Code Division Multiple Access (W-CDMA) cellular phone transmitters without being desensitised. The use of a digital Frequency Shift Keying (FSK) discriminator means that no discriminator tank is needed and its excellent performance in the presence of noise allows BlueCore3-ROM to exceed the Bluetooth requirements for co-channel and adjacent channel rejection.

7.1.1 Low Noise Amplifier

The LNA can be configured to operate in single-ended or differential mode. Single-ended mode is used for Class 1 Bluetooth operation and differential mode is used for Class 2 operation.

7.1.2 Analogue to Digital Converter

The Analogue to Digital Converter (ADC) is used to implement fast Automatic Gain Control (AGC). The ADC samples the Received Signal Strength Indicator (RSSI) voltage on a slot-by-slot basis. The front-end LNA gain is changed according to the measured RSSI value, keeping the first mixer input signal within a limited range. This improves the dynamic range of the receiver, improving performance in interference limited environments.

7.2 RF Transmitter

7.2.1 IQ Modulator

The transmitter features a direct IQ modulator to minimise the frequency drift during a transmit timeslot which results in a controlled modulation index. A digital baseband transmit filter provides the required spectral shaping.

7.2.2 Power Amplifier

The internal Power Amplifier (PA) has a maximum output power of +6dBm allowing BlueCore3-ROM to be used in Class 2 and Class 3 radios without an external RF PA. Support for transmit power control allows a simple implementation for Class 1 with an external RF PA.

7.2.3 Auxiliary DAC

An 8-bit voltage Auxiliary DAC is provided for power control of an external PA for Class 1 operation.

7.3 RF Synthesiser

The radio synthesiser is fully integrated onto the die with no requirement for an external Voltage Controlled Oscillator (VCO) screening can, varactor tuning diodes or LC resonators. The synthesiser is guaranteed to lock in sufficient time across the guaranteed temperature range to meet the Bluetooth specification V1.2.

7.4 Clock Input and Generation

The reference clock for the system is generated from a TCXO or crystal input between 8MHz and 40MHz. All internal reference clocks are generated using a phase locked loop, which is locked to the external reference frequency.

7.5 Baseband and Logic

7.5.1 Memory Management Unit

The Memory Management Unit (MMU) provides a number of dynamically allocated ring buffers that hold the data which is in transit between the host and the air or vice versa. The dynamic allocation of memory ensures efficient use of the available Random Access Memory (RAM) and is performed by hardware MMU to minimise the overheads on the processor during data/voice transfers.

7.5.2 Burst Mode Controller

During radio transmission the Burst Mode Controller (BMC) constructs a packet from header information previously loaded into memory-mapped registers by the software and payload data/voice taken from the appropriate ring buffer in the RAM. During radio reception, the BMC stores the packet header in memory-mapped registers and the payload data in the appropriate ring buffer in RAM. This architecture minimises the intervention required by the processor during transmission and reception.

7.5.3 Physical Layer Hardware Engine DSP

Dedicated logic is used to perform the following:

- Forward error correction
- Header error control
- Cyclic redundancy check
- Encryption
- Data whitening
- Access code correlation
- Audio transcoding

The following voice data translations and operations are performed by firmware:

- A-law/ μ -law/linear voice data (from host)
- A-law/ μ -law/Continuously Variable Slope Delta (CVSD) (over the air)
- Voice interpolation for lost packets
- Rate mismatches

The hardware supports all optional and mandatory features of Bluetooth v1.2 including AFH and eSCO.

7.5.4 RAM

32Kbytes of on-chip RAM is provided and is shared between the ring buffers used to hold voice/data for each active connection and the general purpose memory required by the Bluetooth stack.

7.5.5 ROM

4Mbits of metal programmable ROM is provided for system firmware implementation.

7.5.6 Flash (BlueCore3-ROM Flash Only)

4Mbits of internal Flash is available on the BlueCore3-ROM Flash, this is used for software prototyping before committing code to ROM.

7.5.7 USB

This is a full speed Universal Serial Bus (USB) interface for communicating with other compatible digital devices. BlueCore3-ROM acts as a USB peripheral, responding to requests from a master host controller such as a PC.

7.5.8 Synchronous Serial Interface

This is a synchronous serial port interface (SPI) for interfacing with other digital devices. The SPI port can be used for system debugging.

7.5.9 UART

This is a standard Universal Asynchronous Receiver Transmitter (UART) interface for communicating with other serial devices.

7.5.10 Audio PCM Interface

The Audio Pulse Code Modulation (PCM) Interface supports continuous transmission and reception of PCM encoded audio data over Bluetooth.

7.6 Microcontroller

The microcontroller, interrupt controller and event timer run the Bluetooth software stack and control the radio and host interfaces. A 16-bit Reduced Instruction Set Computer (RISC) microcontroller is used for low power consumption and efficient use of memory.

7.6.1 Programmable I/O

BlueCore3-ROM has a total of 15 (12 digital and 3 analogue) programmable I/O terminals. These are controlled by firmware running on the device.

8 CSR Bluetooth Software Stacks

BlueCore3-ROM is supplied with Bluetooth v1.2 compliant stack firmware which runs on the internal RISC microcontroller.

The BlueCore3-ROM software architecture allows Bluetooth processing and the application program to be shared in different ways between the internal RISC microcontroller and an external host processor (if any). The upper layers of the Bluetooth stack (above HCI) can be run either on-chip or on the host processor.

8.1 BlueCore HCI Stack

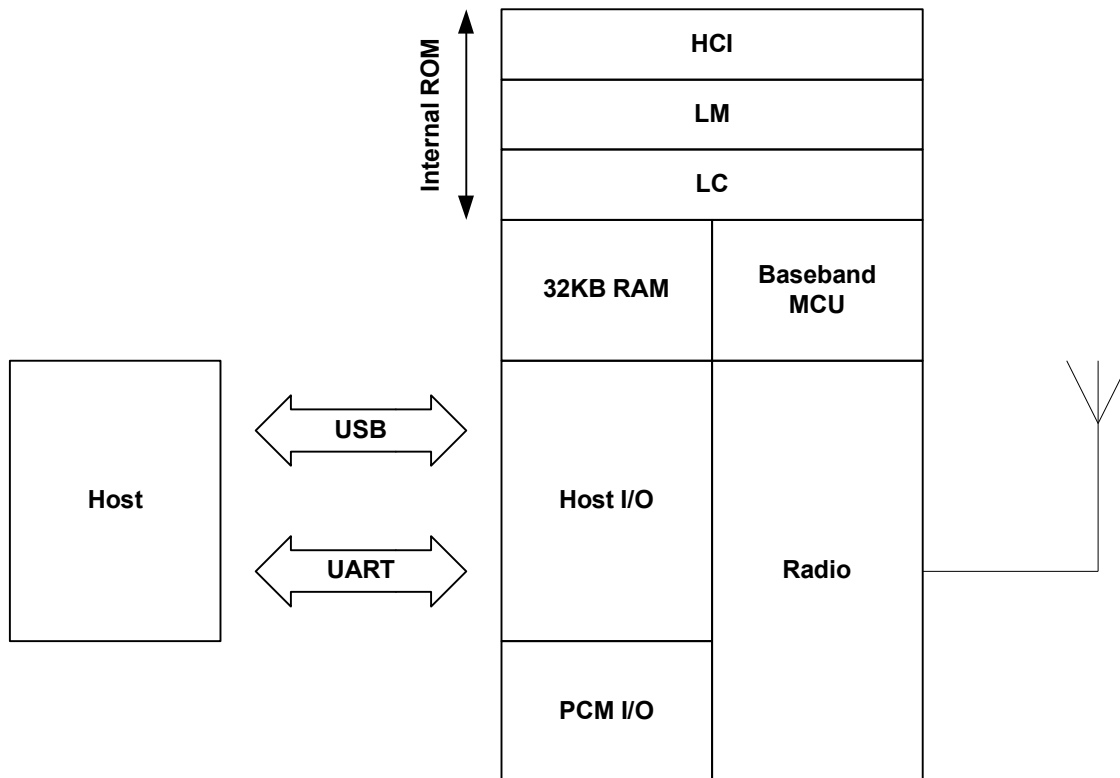

Figure 8.1: BlueCore HCI Stack

In this implementation the internal processor runs the Bluetooth stack up to the Host Controller Interface (HCI). The Host processor must provide all upper layers including the applications.

8.1.1 Key Features of the HCI Stack

New Bluetooth V1.2 Mandatory Functionality

- Adaptive Frequency Hopping (AFH)
- Faster Connections
- Flow and Flush Timeout
- LMP Improvements
- Parameter Ranges

Optional V1.2 functionality supported

- Extended SCO (eSCO), eV3 +CRC, eV4, eV5
- Scatter mode
- LMP Absence Masks, Quality of service and SCO handle
- L2CAP flow and error control
- Synchronisation

Standard Bluetooth Functionality

The firmware has been written against the Bluetooth Core Specification v1.2.

- Bluetooth components: Baseband (including LC), LM and HCI
- Standard USB v2.0 and UART (H5) HCI Transport Layers
- All standard radio packet types
- Full Bluetooth data rate, up to 723.2kbps asymmetric⁽¹⁾
- Operation with up to seven active slaves⁽¹⁾
- Maximum number of simultaneous active ACL connections: 7⁽²⁾
- Maximum number of simultaneous active SCO connections: 3⁽²⁾
- Operation with up to three SCO links, routed to one or more slaves
- Scatternet 2.5 operation
- All standard SCO voice coding, plus “transparent SCO”
- Standard operating modes: page, inquiry, page-scan and inquiry-scan
- All standard pairing, authentication, link key and encryption operations
- Standard Bluetooth power saving mechanisms: Hold, Sniff and Park modes, including “Forced Hold”
- Dynamic control of peers’ transmit power via LMP
- Master/slave switch
- Broadcast
- Channel quality driven data rate
- All standard Bluetooth Test Modes

The firmware’s supported Bluetooth features are detailed in the standard Protocol Implementation Conformance Statement (PICS) documents, available from www.csr.com.

Notes:

- ⁽¹⁾ Maximum allowed by Bluetooth specification v1.2
- ⁽²⁾ Supports all combinations of active ACL and SCO channels, per Bluetooth specification v1.2

Extra Functionality

- The firmware extends the standard Bluetooth functionality with the following features:
- Supports BlueCore Serial Protocol (BCSP) – a proprietary, reliable alternative to the standard Bluetooth UART Host Transport.
- Provides a set of approximately 50 manufacturer-specific HCI extension commands. This command set, called BCCMD (BlueCore Command), provides:
 - Access to the chip's general-purpose PIO port
 - The negotiated effective encryption key length on established Bluetooth links
 - Access to the firmware's random number generator
 - Controls to set the default and maximum transmit powers. These can help minimise interference between overlapping, fixed-location piconet
 - Dynamic UART configuration
 - Radio transmitter enable/disable (a simple command connects to a dedicated hardware switch that determines whether the radio can transmit)
 - The firmware can read the voltage on a pair of the chip's external pins. This is normally used to build a battery monitor, using either VM or host code.
 - A block of BCCMD commands provides access to the chip's "persistent store" configuration database (PS). The database sets the device's Bluetooth address, Class of Device, radio (transmit class) configuration, SCO routing, LM, USB and DFU constants, etc.
 - A UART "break" condition can be used in three ways:
 1. Presenting a UART break condition to the chip can force the chip to perform a hardware reboot
 2. Presenting a break condition at boot time can hold the chip in a low power state, preventing normal initialisation while the condition exists
 3. With H5, the firmware can be configured to send a break to the host before sending data (normally used to wake the host from a Deep Sleep state)
 - A block of "radio test" or BIST commands allows direct control of the chip's radio. This aids the development of modules' radio designs, and can be used to support Bluetooth qualification.
 - Virtual Machine (VM). The firmware provides the VM environment in which to run application-specific code. Although the VM is mainly used with BlueLab and "RFCOMM builds" (alternative firmware builds providing L2CAP, SDP and RFCOMM), the VM can be used with this build to perform simple tasks such as flashing LEDs via the chip's PIO port.
 - Hardware low power modes: shallow sleep and deep sleep. The chip drops into modes that significantly reduce power consumption when the software goes idle.
 - SCO channels are normally routed over HCI over BCSP, H5 or USB. However, up to three SCO channels can be routed over the chip's single PCM port at the same time as routing any other SCO channels over HCI.
 - Co-operative existence with 802.11b chipsets

Always refer to the Firmware Release Note for the specific functionality of a particular build

8.2 BlueCore RFCOMM Stack

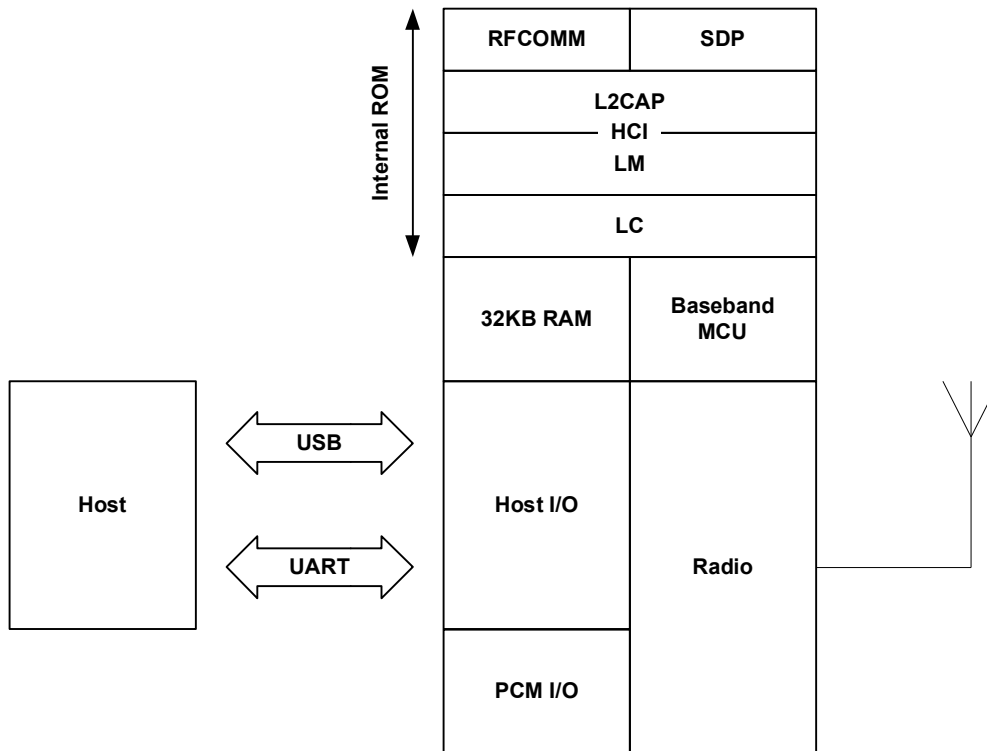

Figure 8.2: BlueCore RFCOMM Stack

In this version of the firmware the upper layers of the Bluetooth stack up to RFCOMM are run on-chip. This reduces host-side software and hardware requirements at the expense of some of the power and flexibility of the HCI only stack.

8.2.1 Key Features of the BlueCore3-ROM RFCOMM Stack

Interfaces to Host

- RFCOMM, an RS-232 serial cable emulation protocol
- SDP, a service database look-up protocol

Connectivity

- Maximum number of active slaves: 3
- Maximum number of simultaneous active ACL connections: 3
- Maximum number of simultaneous active SCO connections: 3
- Data Rate: up to 350Kb/s

Security

- Full support for all Bluetooth security features up to and including strong (128-bit) encryption.

Power Saving

- Full support for all Bluetooth power saving modes (Park, Sniff and Hold).

Data Integrity

- CQDDR increases the effective data rate in noisy environments.
- RSSI used to minimise interference to other radio devices using the ISM band.

8.3 BlueCore Virtual Machine Stack

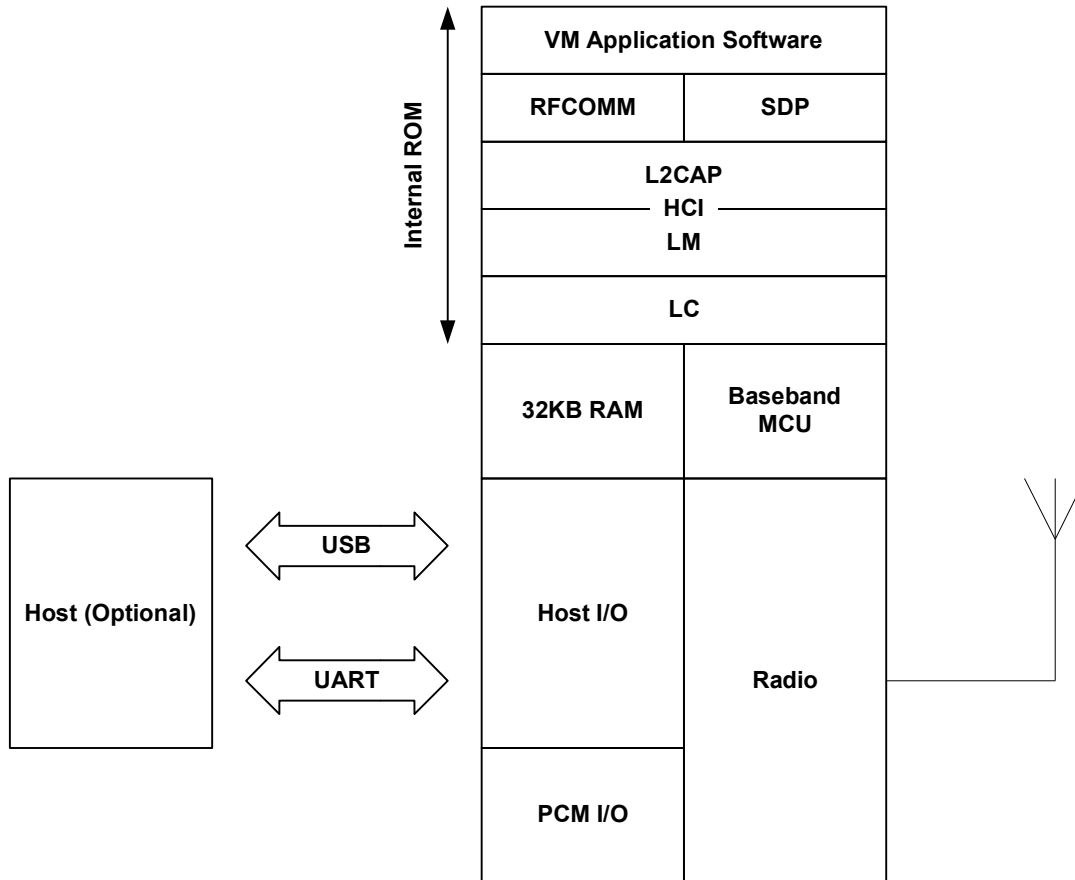

Figure 8.3: Virtual Machine

This version of the stack firmware requires no host processor although the serial communication ports can still be used under the control of the VM application. All software layers, including application software, run on the internal RISC microcontroller in a protected user software execution environment known as a virtual machine (VM).

The user may write custom application code to run on the BlueCore VM using BlueLab™ software development kit (SDK) supplied with the BlueLab and Casira development kits, available separately from CSR. This code will then execute alongside the main BlueCore firmware. The user is able to make calls to the BlueCore firmware for various operations.

The execution environment is structured so the user application does not adversely affect the main software routines, thus ensuring that the Bluetooth stack software component does not need re-qualification when the application is changed.

Using the VM and the BlueLab SDK the user is able to develop applications such as a cordless headset or other profiles without the requirement of a host controller. BlueLab is supplied with example code including a full implementation of the headset profile.

On successful completion of firmware development and testing using BlueCore3-ROM Flash, CSR can commit the code to a mask set for mass production of the device. A Non Recurring Engineering (NRE) charge will be required.

Note:

Sample applications to control PIO lines can also be written with BlueLab SDK and the VM for the HCI stack.

8.4 BlueCore HID Stack

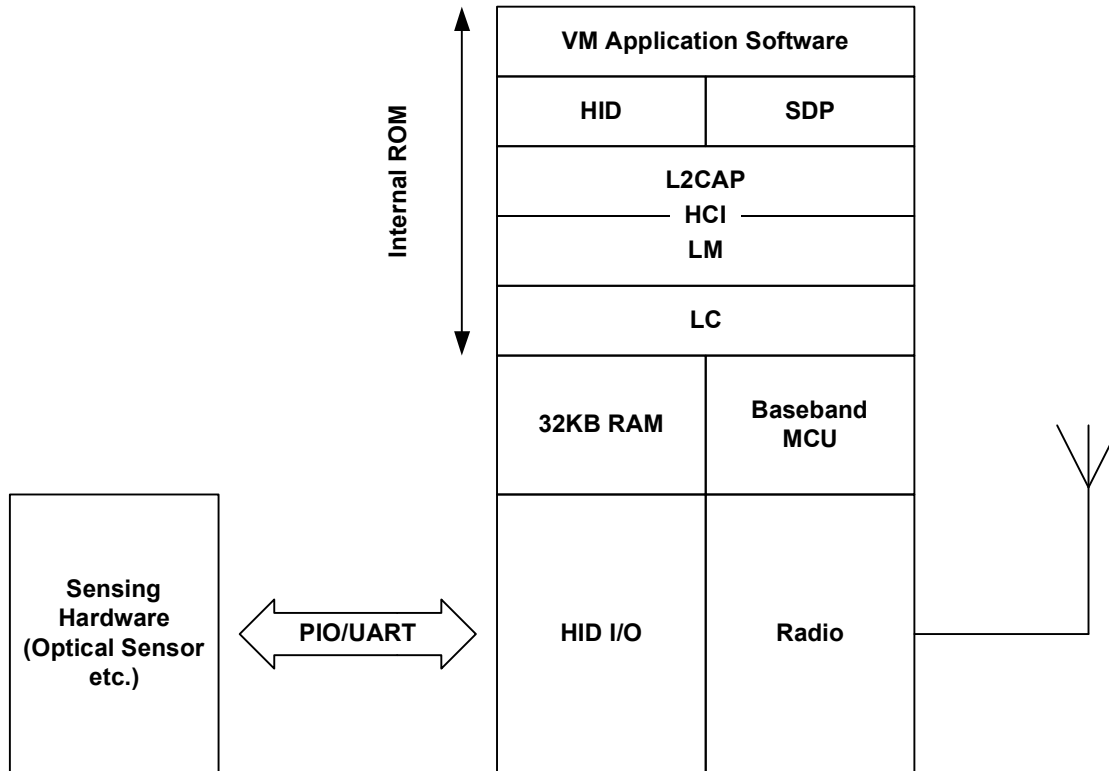

Figure 8.4: HID Stack

This version of the stack firmware requires no host processor. All software layers, including application software, run on the internal RISC microcontroller in a protected user software execution environment known as a virtual machine (VM).

The user may write custom application code to run on the BlueCore VM using BlueLab Professional software development kit (SDK) supplied with the BlueLab Professional and Casira development kits, available separately from CSR. This code will then execute alongside the main BlueCore firmware. The user is able to make calls to the BlueCore firmware for various operations.

The execution environment is structured so the user application does not adversely affect the main software routines, thus ensuring that the Bluetooth stack software component does not need re-qualification when the application is changed.

Using the VM and the BlueLab Professional SDK the user is able to develop Bluetooth HID devices such as an optical mouse or keyboard. The user is able to customise features such as power management and connect/reconnect behaviour.

The HID I/O component in the HID stack controls low latency data acquisition from external sensor hardware. With this component running in native code, it does not incur the overhead of the VM code interpreter. Supported external sensors include 5 mouse buttons, the Agilent ADNS-2030 optical sensor, quadrature scroll wheel, direct coupling to a keyboard matrix and a UART interface to custom hardware.

On successful completion of firmware development and testing using BlueCore3-ROM Flash, CSR can commit the code to a mask set for mass production of the device. A non recurring engineering (NRE) charge will be required.

A reference schematic for implementing a three button, optical mouse with scroll wheel is available from CSR.

8.5 BCCHS Software

BlueCore Embedded Host Software is designed to enable CSR customers to implement Bluetooth functionality into embedded products quickly, cheaply and with low risk.

BCCHS is developed to work with CSR's family of BlueCore IC's. BCCHS is intended for embedded products that have a host processor for running BCCHS and the Bluetooth application e.g. a mobile phone or a PDA. BCCHS together with the BlueCore IC with embedded Bluetooth core stack (L2CAP, RFCOMM and SDP) is a complete Bluetooth system solution from RF to profiles.

BCCHS includes most of the Bluetooth intelligence and gives the user a simple API. This makes it possible to develop a Bluetooth product without in-depth Bluetooth knowledge.

The BlueCore Embedded Host Software contains 3 elements:

- Example Drivers (BCSP and proxies)
- Bluetooth Profile Managers
- Example Applications

The profiles are qualified which makes the qualification of the final product very easy. BCCHS is delivered with source code (ANSI C). With BCCHS also come example applications in ANSI C, which makes the process of writing the application easier.

8.6 Additional Software for Other Embedded Applications

When the upper layers of the Bluetooth protocol stack are run as firmware on BlueCore3-ROM, a UART software driver is supplied that presents the L2CAP, RFCOMM and Service Discovery (SDP) APIs to higher Bluetooth stack layers running on the host. The code is provided as 'C' source or object code.

8.7 CSR Development Systems

CSR's BlueLab and Casira development kits are available to allow the evaluation of the BlueCore3 hardware and software, and as toolkits for developing on-chip and host software.

9 Device Terminal Descriptions

9.1 RF Ports

The BlueCore3-ROM RF_IN terminal can be configured as either a single ended or differential input. The operational mode is determined by the setting the PS Key PSKEY_TXRX_PIO_CONTROL (0x20).

9.2 Transmitter/Receiver Inputs and Outputs

Terminals TX_A and TX_B form a balanced current output. They require a DC path to VDD and should be connected through a balun to the antenna. The output impedance is capacitive and remains constant, regardless of whether the transmitter is enabled or disabled. For Class 2 operation these terminals also act as differential receive input terminals with an internal TX/RX switch.

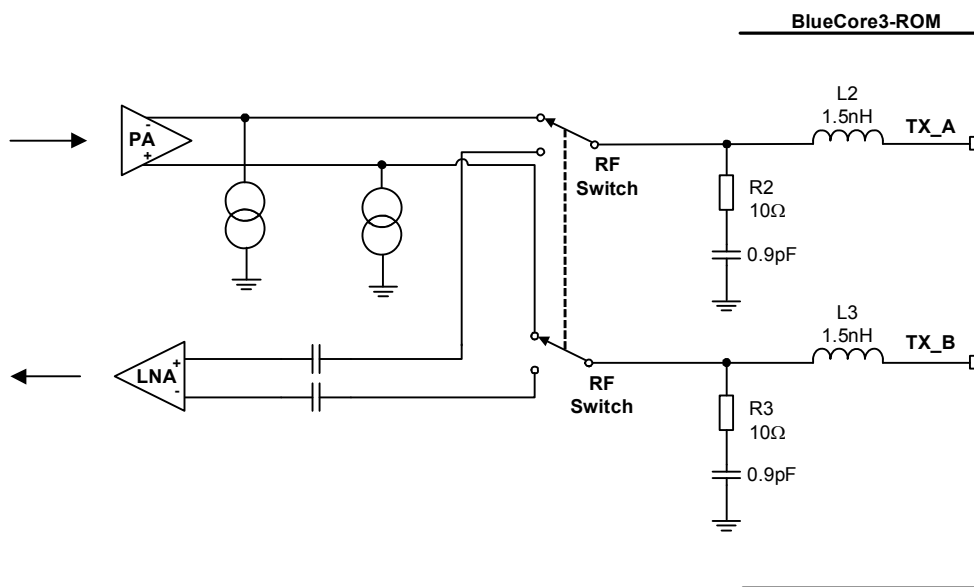

Figure 9.1: Circuit TX/RX_A and TX/RX_B

For the 6 x 6 package, an off-chip balun and filter are required. These may comprise separate discrete components, see Figure 10.1, differential filter only, or as printed structures.

For Class 1 operation the RF_IN ball is provided which is single-ended. A swing of up to 0.5V root mean squared (rms) can be tolerated at this terminal. An external antenna switch can be connected to RF_IN.

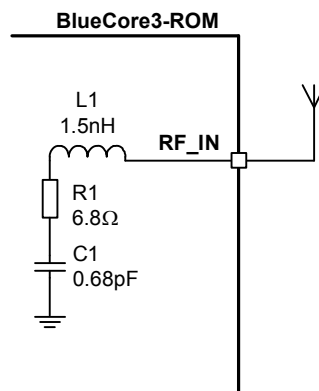

Figure 9.2: Circuit RF_IN

9.2.1 Transmitter S-Parameters

Freq (MHz)	S11		S21		S12		S22	
	Real	Imaginary	Real	Imaginary	Real	Imaginary	Real	Imaginary
2402	-8.18E-03	-6.79E-01	2.47E-03	6.48E-02	-9.96E-04	7.01E-02	-3.74E-02	-6.65E-01
2408	-8.18E-03	-6.79E-01	2.47E-03	6.90E-02	-9.96E-04	6.20E-02	-3.74E-02	-6.65E-01
2414	-9.98E-03	-6.79E-01	2.11E-03	6.93E-02	-1.77E-03	6.33E-02	-3.89E-02	-6.65E-01
2420	-1.45E-02	-6.78E-01	2.89E-03	6.89E-02	-1.22E-03	6.29E-02	-4.33E-02	-6.64E-01
2426	-1.79E-02	-6.76E-01	3.16E-03	6.86E-02	-1.21E-03	6.28E-02	-4.62E-02	-6.62E-01
2432	-2.19E-02	-6.75E-01	3.59E-03	6.86E-02	-1.08E-03	6.30E-02	-4.91E-02	-6.61E-01
2438	-2.56E-02	-6.74E-01	3.89E-03	6.83E-02	-9.35E-04	6.32E-02	-5.28E-02	-6.60E-01
2444	-2.87E-02	-6.73E-01	4.07E-03	6.81E-02	-8.20E-04	6.33E-02	-5.67E-02	-6.60E-01
2450	-3.27E-02	-6.72E-01	4.25E-03	6.79E-02	-6.83E-04	6.35E-02	-6.08E-02	-6.59E-01
2456	-3.55E-02	-6.72E-01	4.46E-03	6.77E-02	-3.59E-04	6.36E-02	-6.45E-02	-6.58E-01
2462	-3.94E-02	-6.71E-01	4.73E-03	6.75E-02	-1.26E-04	6.38E-02	-6.71E-02	-6.59E-01
2468	-4.33E-02	-6.70E-01	4.80E-03	6.72E-02	1.68E-04	6.38E-02	-7.14E-02	-6.57E-01
2474	-4.70E-02	-6.70E-01	4.80E-03	6.70E-02	3.78E-04	6.38E-02	-7.45E-02	-6.57E-01
2480	-5.03E-02	-6.70E-01	4.85E-03	6.68E-02	5.26E-04	6.38E-02	-7.71E-02	-6.56E-01

Table 9.1: Transmit Impedance

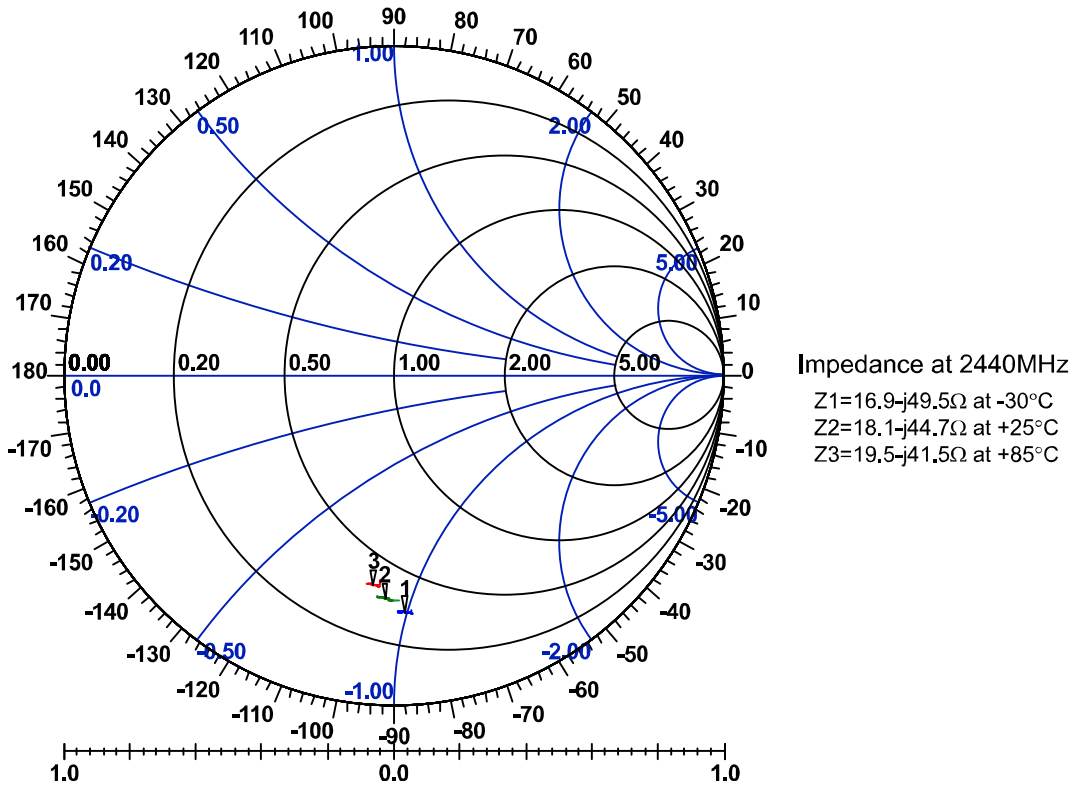

Figure 9.3: TX_A PL35

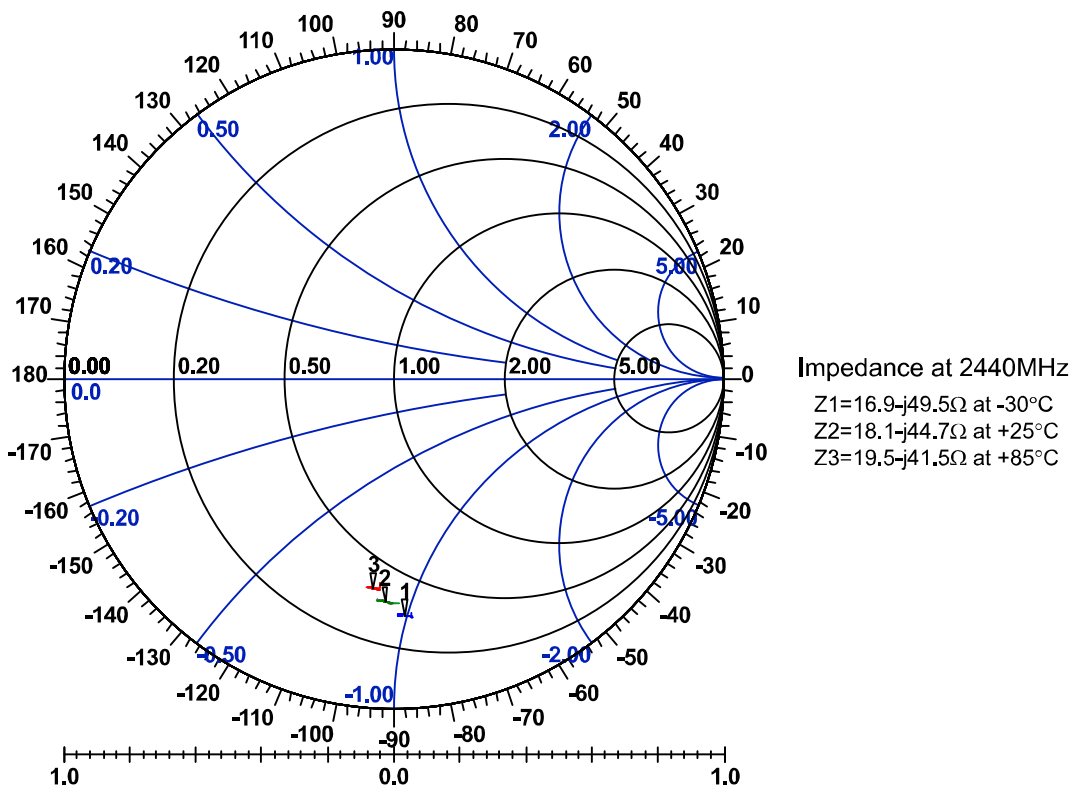
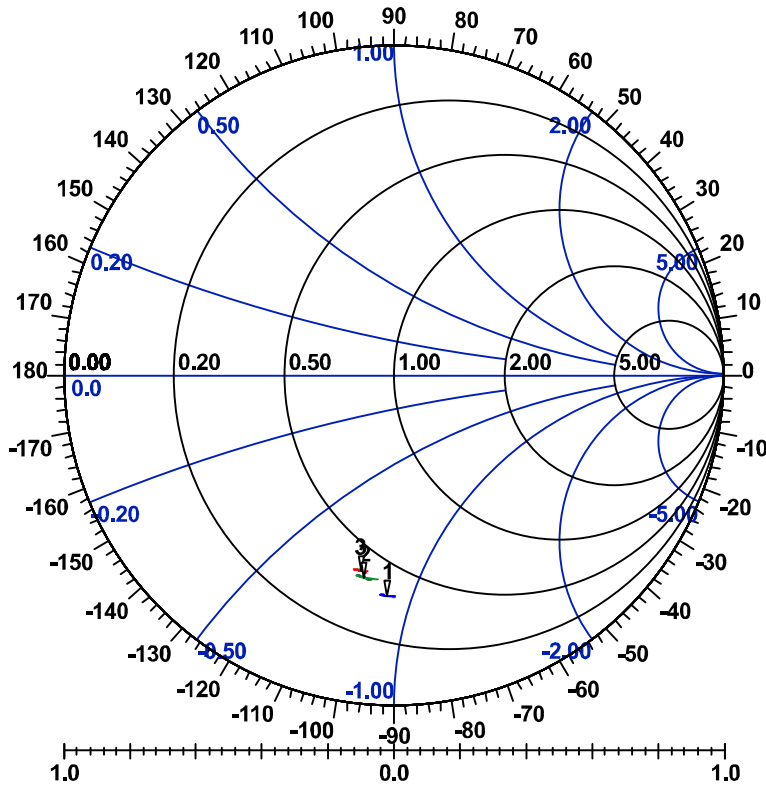

Figure 9.4: TX_A PL50

Production Information



Impedance at 2440MHz

 $Z1=18.7-j44.8\Omega$ at -30°C
 $Z2=19.8-j39.2\Omega$ at $+25^\circ\text{C}$
 $Z3=20.5-j37.9\Omega$ at $+85^\circ\text{C}$

Figure 9.5: TX_A PL63

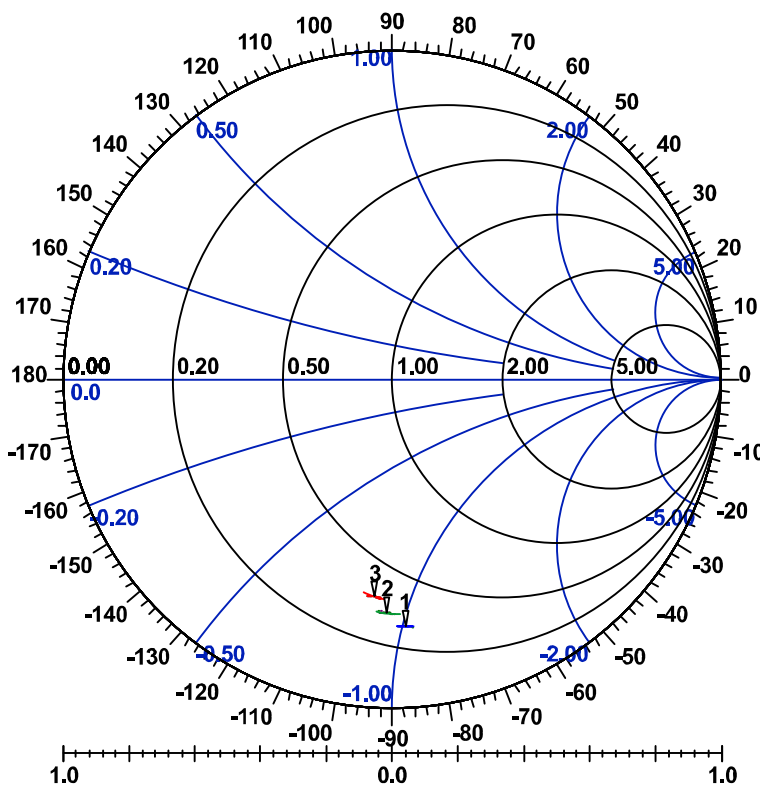

Impedance at 2440MHz

 $Z1=14.8-j50.6\Omega$ at -30°C
 $Z2=16.3-j46.2\Omega$ at $+25^\circ\text{C}$
 $Z3=18.2-j42.7\Omega$ at $+85^\circ\text{C}$

Figure 9.6: TX_B PL35

Production Information

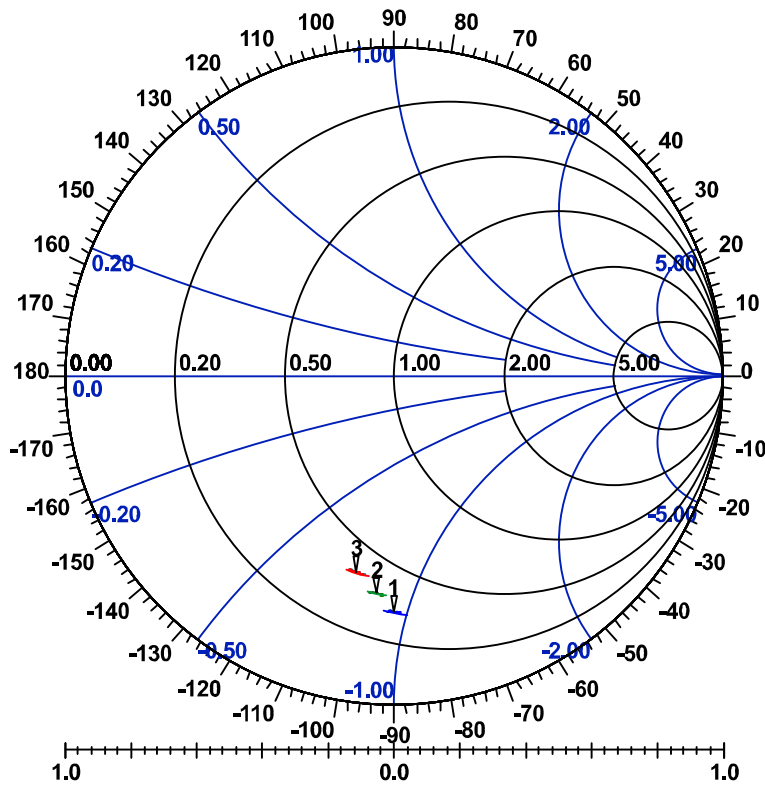

Impedance at 2440MHz

$Z1=16.2-j47.3\Omega$ at -30°C
 $Z2=18.2-j42.7\Omega$ at $+25^\circ\text{C}$
 $Z3=19.9-j37.3\Omega$ at $+85^\circ\text{C}$

Figure 9.7: TX_B PL50

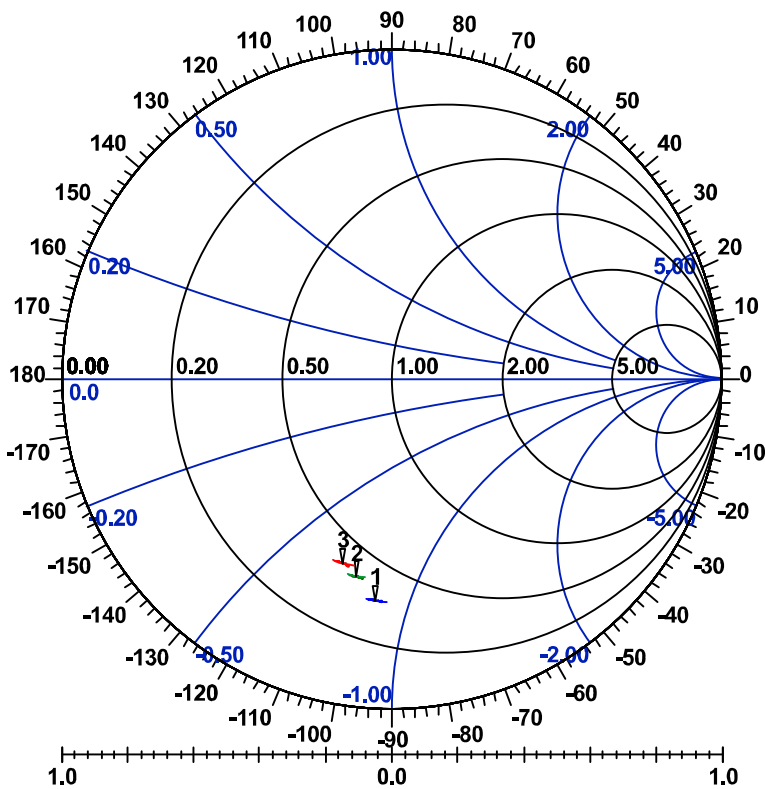

Impedance at 2440MHz

$Z1=17.7-j43.3\Omega$ at -30°C
 $Z2=20.0-j37.85\Omega$ at $+25^\circ\text{C}$
 $Z3=20.5-j34.2\Omega$ at $+85^\circ\text{C}$

Figure 9.8: TX_B PL63

9.2.2 Receiver S-Parameters

Freq (MHz)	S11		S21		S12		S22	
	Real	Imaginary	Real	Imaginary	Real	Imaginary	Real	Imaginary
2402	8.99E-02	-7.74E-01	1.29E-02	2.86E-02	1.29E-02	2.84E-02	3.49E-02	-7.58E-01
2408	8.62E-02	-7.74E-01	1.27E-02	2.87E-02	1.25E-02	2.84E-02	3.14E-02	-7.58E-01
2414	8.40E-02	-7.74E-01	1.24E-02	2.88E-02	1.23E-02	2.84E-02	2.73E-02	-7.57E-01
2420	8.08E-02	-7.74E-01	1.22E-02	2.88E-02	1.20E-02	2.86E-02	2.32E-02	-7.58E-01
2426	7.79E-02	-7.74E-01	1.19E-02	2.89E-02	1.18E-02	2.87E-02	1.91E-02	-7.57E-01
2432	7.40E-02	-7.74E-01	1.18E-02	2.91E-02	1.15E-02	2.88E-02	1.48E-02	-7.57E-01
2438	7.06E-02	-7.75E-01	1.15E-02	2.92E-02	1.13E-02	2.90E-02	1.07E-02	-7.56E-01
2444	6.74E-02	-7.74E-01	1.13E-02	2.93E-02	1.11E-02	2.91E-02	6.50E-03	-7.55E-01
2450	6.33E-02	-7.74E-01	1.10E-02	2.93E-02	1.08E-02	2.91E-02	1.53E-03	-7.56E-01
2456	6.06E-02	-7.74E-01	1.07E-02	2.94E-02	1.05E-02	2.92E-02	-3.51E-03	-7.55E-01
2462	5.66E-02	-7.74E-01	1.05E-02	2.94E-02	1.03E-02	2.93E-02	-6.32E-03	-7.56E-01
2468	5.33E-02	-7.74E-01	1.01E-02	2.95E-02	9.94E-03	2.95E-02	-1.24E-02	-7.54E-01
2474	5.00E-02	-7.75E-01	9.75E-03	2.96E-02	9.65E-03	2.97E-02	-1.71E-02	-7.54E-01
2480	4.73E-02	-7.75E-01	9.46E-03	2.98E-02	9.35E-03	2.98E-02	-2.15E-02	-7.52E-01

Table 9.2: Balanced Receiver Impedance

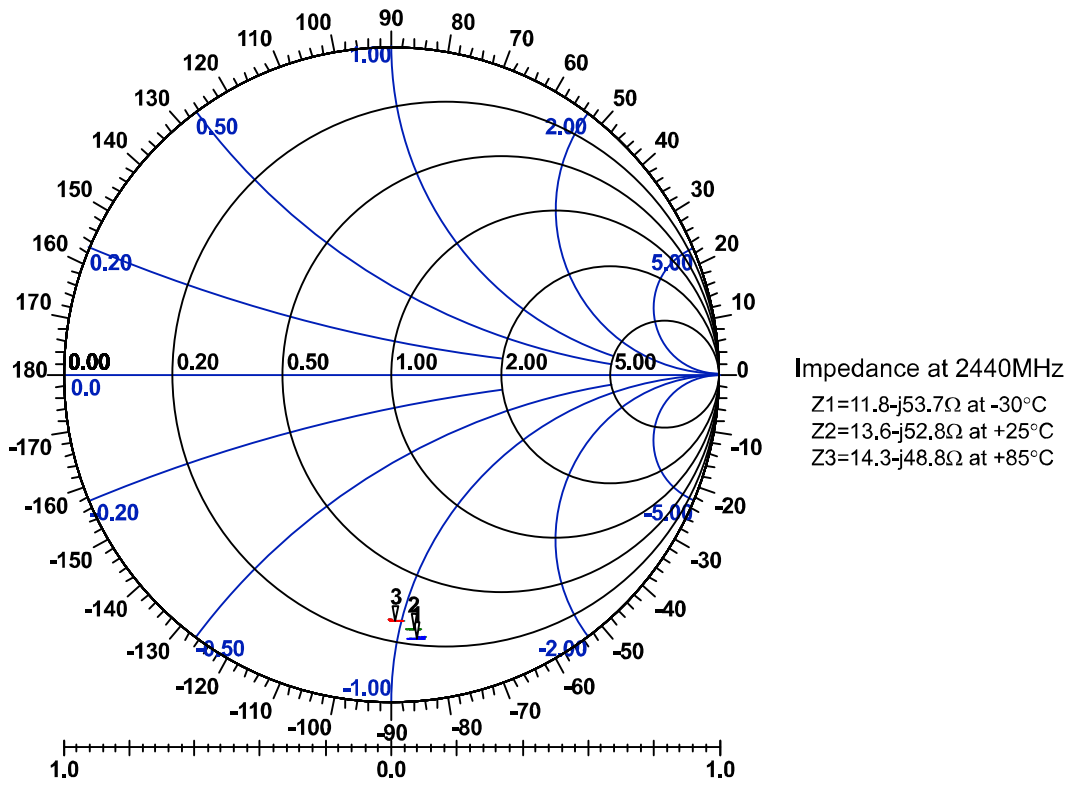

Figure 9.9: RX_A Balanced

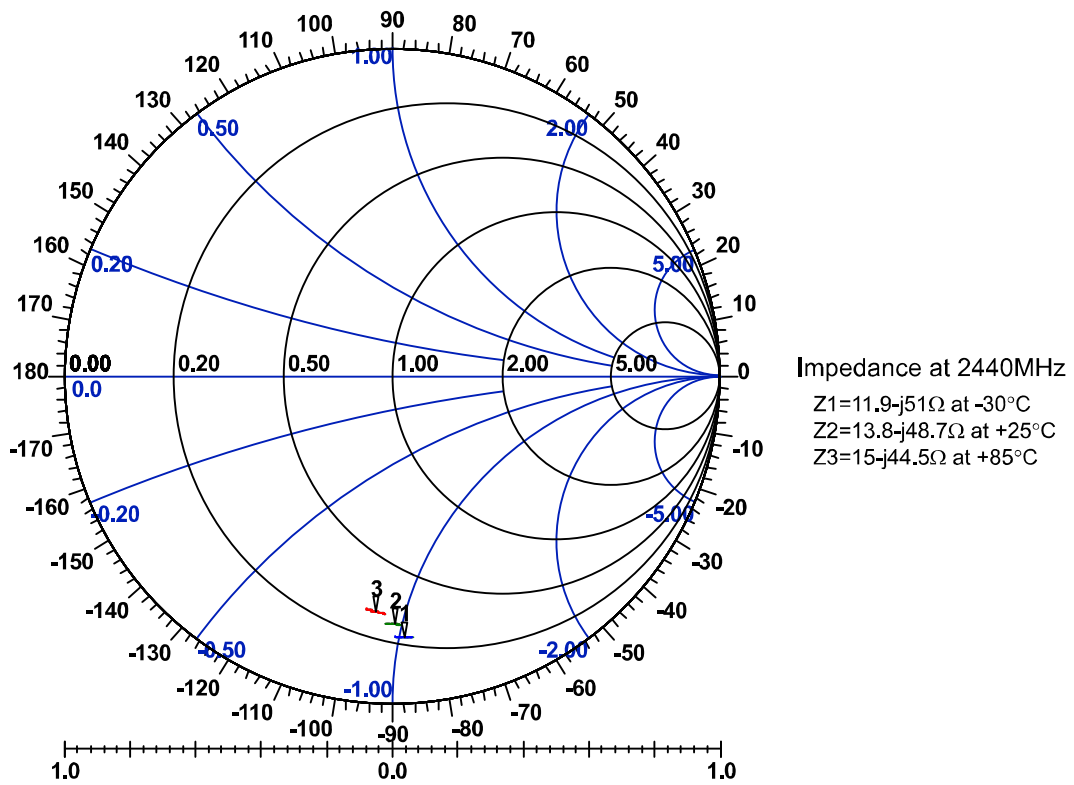

Figure 9.10: RX_B Balanced

9.2.3 Single Ended Impedance

Frequency (MHz)	S11	
	Real	Imaginary
2402	4.70E-01	-7.23E-01
2408	4.65E-01	-7.24E-01
2414	4.63E-01	-7.27E-01
2420	4.57E-01	-7.29E-01
2426	4.54E-01	-7.29E-01
2432	4.53E-01	-7.29E-01
2438	4.51E-01	-7.31E-01
2444	4.47E-01	-7.32E-01
2450	4.46E-01	-7.33E-01
2456	4.44E-01	-7.34E-01
2462	4.44E-01	-7.34E-01
2468	4.39E-01	-7.37E-01
2474	4.35E-01	-7.39E-01
2480	4.30E-01	-7.39E-01

Table 9.3: Single Ended Impedance

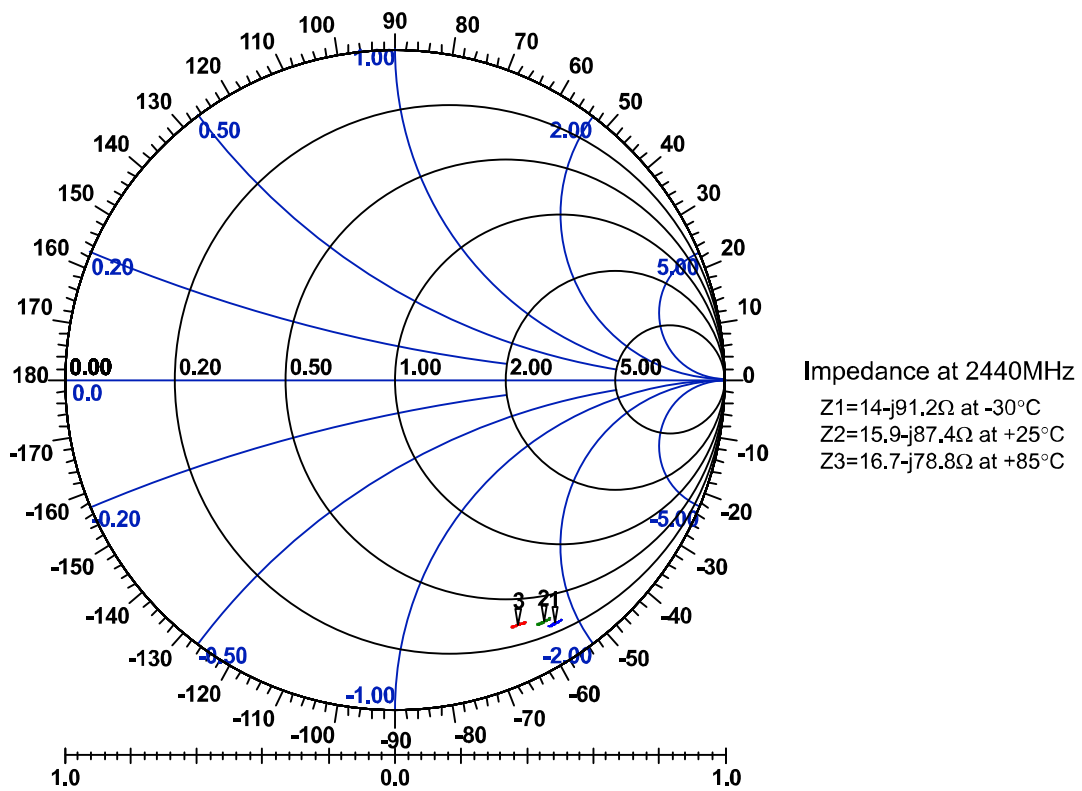

Figure 9.11: RX Un-Balanced

9.3 External Reference Clock Input (XTAL_IN)

The BlueCore3-ROM RF local oscillator and internal digital clocks are derived from the reference clock at the BlueCore3-ROM XTAL_IN input. This reference may be either an external clock or from a crystal connected between XTAL_IN and XTAL_OUT. The crystal mode is described in Section 9.4.

9.3.1 External Mode

BlueCore3-ROM can be configured to accept an external reference clock (from another device, such as TCXO) at XTAL_IN by connecting XTAL_OUT to ground. The external clock can either be a digital level square wave or sinusoidal and this may be directly coupled to XTAL_IN without the need for additional components. If the peaks of the reference clock are below VSS_ANA or above VDD_ANA, it must be driven through a DC blocking capacitor (~33pF) connected to XTAL_IN. A digital level reference clock gives superior noise immunity as the high slew rate clock edges have lower voltage to phase conversion.

The external clock signal should meet the specifications in Table 9.5:

	Min	Typ	Max
Frequency ⁽¹⁾	7.5MHz	16MHz	40MHz
Duty cycle	20:80	50:50	80:20
Edge Jitter (At Zero Crossing)	-	-	15ps rms
Signal Level	400mV pk-pk	-	VDD_ANA ⁽²⁾⁽³⁾

Table 9.4: External Clock Specifications

Notes:

- (1) The frequency should be an integer multiple of 250kHz except for the CDMA/3G frequencies
- (2) VDD_ANA is 1.8V nominal
- (3) If the external clock is driven through a DC blocking capacitor then maximum allowable amplitude is reduced from VDD_ANA to 800mV pk-pk

9.3.2 XTAL_IN Impedance in External Mode

The impedance of the XTAL_IN will not change significantly between operating modes, typically 10fF. When transitioning from deep sleep to an active state a spike of up to 1pC may be measured. For this reason it is recommended that a buffered clock input be used.

9.3.3 Clock Timing Accuracy

As Figure 9.12 indicates, the 250ppm timing accuracy on the external clock is required 7ms after the assertion of the system clock request line. This is to guarantee that the firmware can maintain timing accuracy in accordance with the Bluetooth v1.2 specification. Radio activity may occur after 11ms, therefore at this point, the timing accuracy of the external clock source must be within 20ppm.

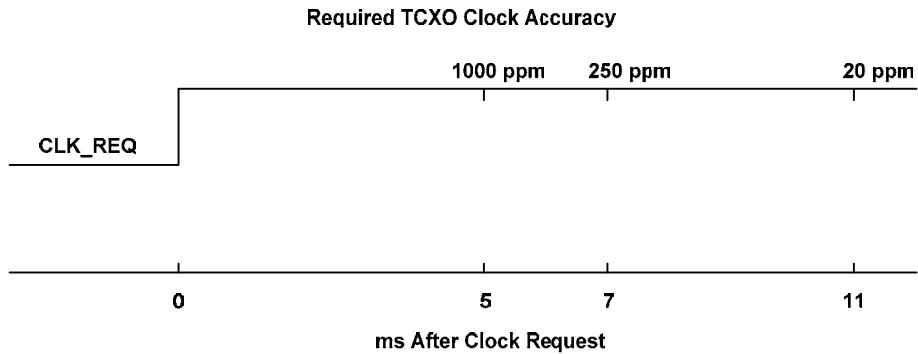

Figure 9.12: TCXO Clock Accuracy

9.3.4 Clock Start-Up Delay

BlueCore3-ROM hardware incorporates an automatic 5ms delay after the assertion of the system clock request signal before running firmware. This is suitable for most applications using an external clock source. However, there may be scenarios where the clock cannot be guaranteed to either exist or be stable after this period. Under these conditions, BlueCore3-ROM firmware provides a software function which will extend the system clock request signal by a period stored in PSKEY_CLOCK_STARTUP_DELAY. This value is set in milliseconds from 5-31ms.

This PS Key allows the designer to optimise a system where clock latencies may be longer than 5ms while still keeping the current consumption of BlueCore3-ROM as low as possible. BlueCore3-ROM will consume about 2mA of current for the duration of PSKEY_CLOCK_STARTUP_DELAY before activating the firmware.

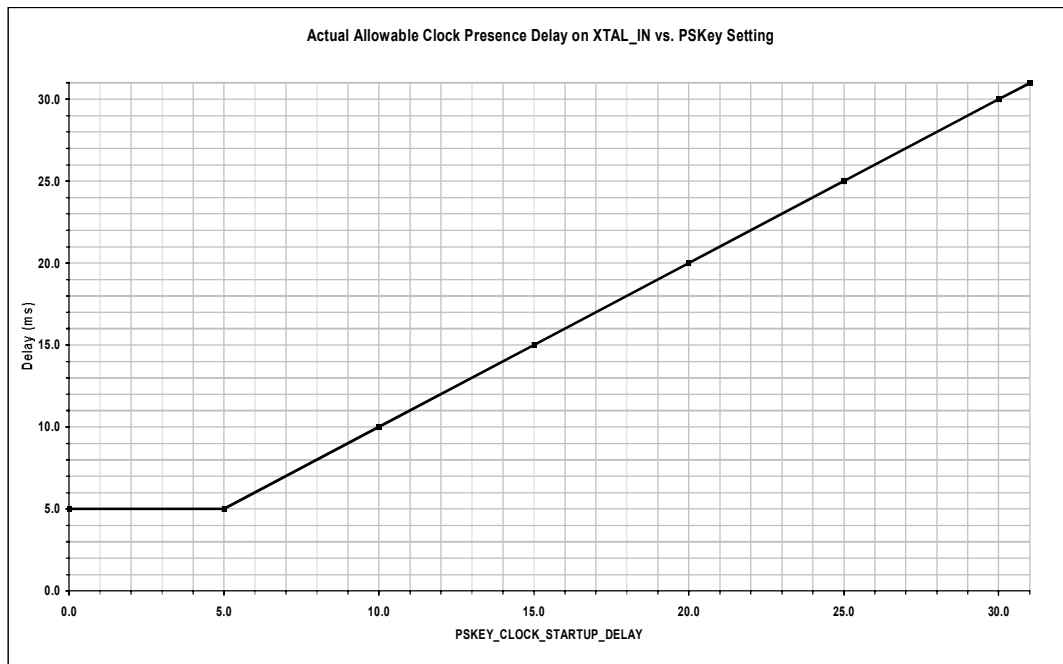

Figure 9.13: Actual Allowable Clock Presence Delay on XTAL_IN vs. PS Key Setting

9.3.5 Input Frequencies and PS Key Settings

BlueCore3-ROM should be configured to operate with the chosen reference frequency. This is accomplished by setting the PS Key PSKEY_ANA_FREQ (0x1fe) for all frequencies with an integer multiple of 250KHz. The input frequency default setting in BlueCore3-ROM is 26MHz.

The following CDMA/3G TCXO frequencies are also catered for: 7.68, 14.4, 15.36, 16.2, 16.8, 19.2, 19.44, 19.68, 19.8 and 38.4MHz. This is accomplished by also changing PSKEY PLL_FREQ_REF (0xabc).

Reference Crystal Frequency (MHz)	PSKEY_ANA_FREQ (0x1fe) (Units of 1kHz)
7.68	7680
14.40	14400
15.36	15360
16.20	16200
16.80	16800
19.20	19200
19.44	19440
19.68	19680
19.80	19800
38.40	38400
n x 250kHz	-
+26.00 Default	26000

Table 9.5: PS Key Values for CDMA/3G phone TCXO Frequencies

9.4 Crystal Oscillator (XTAL_IN, XTAL_OUT)

The BlueCore3-ROM RF local oscillator and internal digital clocks are derived from the reference clock at the BlueCore3-ROM XTAL_IN input. This reference may be either an external clock or from a crystal connected between XTAL_IN and XTAL_OUT. The external reference clock mode is described in Section 9.3.

9.4.1 XTAL Mode

BlueCore3-ROM contains a crystal driver circuit. This operates with an external crystal and capacitors to form a Pierce oscillator.

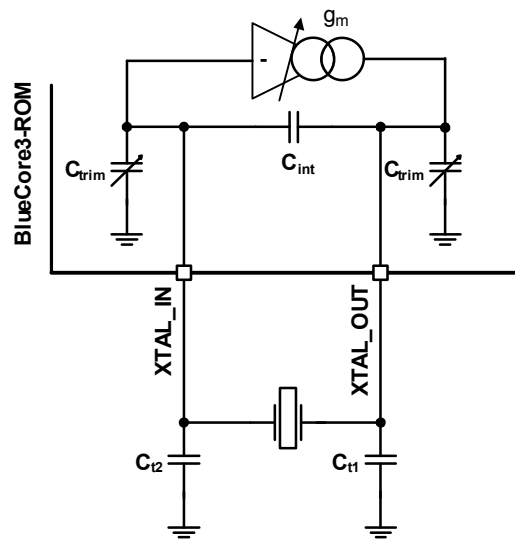

Figure 9.14: Crystal Driver Circuit

Figure 9.15 shows an electrical equivalent circuit for a crystal. The crystal appears inductive near its resonant frequency. It forms a resonant circuit with its load capacitors.

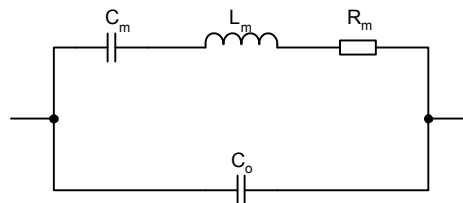

Figure 9.15: Crystal Equivalent Circuit

The resonant frequency may be trimmed with the crystal load capacitance. BlueCore3-ROM contains variable internal capacitors to provide a fine trim.

The BlueCore3-ROM driver circuit is a transconductance amplifier. A voltage at XTAL_IN generates a current at XTAL_OUT. The value of transconductance is variable and may be set for optimum performance.

9.4.2 Load Capacitance

For resonance at the correct frequency the crystal should be loaded with its specified load capacitance, which is defined for the crystal. This is the total capacitance across the crystal viewed from its terminals. BlueCore3-ROM provides some of this load with the capacitors C_{trim} and C_{int} . The remainder should be from the external capacitors labelled C_{t1} and C_{t2} . C_{t1} should be three times the value of C_{t2} for best noise performance. This maximises the signal swing, hence slew rate at XTAL_IN, to which all on chip clocks are referred. Crystal load capacitance, C_l is calculated with the following equation:

$$C_l = C_{int} + \frac{C_{trim}}{2} + \frac{C_{t1} \cdot C_{t2}}{C_{t1} + C_{t2}}$$

Equation 9.1: Load Capacitance

Where:

$C_{trim} = 3.4\text{pF}$ nominal (Mid range setting)

$C_{int} = 1.5\text{pF}$

Note:

C_{int} does not include the crystal internal self capacitance, it is the driver self capacitance

9.4.3 Frequency Trim

BlueCore3-ROM enables frequency adjustments to be made. This feature is typically used to remove initial tolerance frequency errors associated with the crystal. Frequency trim is achieved by adjusting the crystal load capacitance with on chip trim capacitors, C_{trim} . The value of C_{trim} is set by a 6-bit word in the Persistent Store Key PSKEY_ANA_FTRIM (0x1f6). Its value is calculated thus:

$$C_{trim} = 110 \text{ fF} \times \text{PSKEY_ANA_FTRIM}$$

Equation 9.2: Trim Capacitance

There are two C_{trim} capacitors, which are both connected to ground. When viewed from the crystal terminals, they appear in series so each least significant bit (LSB) increment of frequency trim presents a load across the crystal of 55fF.

The frequency trim is described by Equation 9.3:

$$\frac{\Delta(F_x)}{F_x} = \text{pullability} \times 55 \times 10^{-3} \text{ (ppm / LSB)}$$

Equation 9.3: Frequency Trim

Where F_x is the crystal frequency and pullability is a crystal parameter with units of ppm/pF. Total trim range is 63 times the value above.

If not specified, the pullability of a crystal may be calculated from its motional capacitance with Equation 9.4:

$$\frac{\partial(F_x)}{\partial(C)} = F_x \cdot \frac{C_m}{4(C_l + C_0)^2}$$

Equation 9.4: Pullability

Where:

C_0 = Crystal self capacitance (shunt capacitance)

C_m = Crystal motional capacitance (series branch capacitance in crystal model). See Figure 9.15.

Note:

It is a Bluetooth requirement that the frequency is always within $\pm 20\text{ppm}$. The trim range should be sufficient to pull the crystal within $\pm 5\text{ppm}$ of the exact frequency. This leaves a margin of $\pm 15\text{ppm}$ for frequency drift with ageing and temperature. A crystal with an ageing and temperature drift specification of better than $\pm 15\text{ppm}$ is required.

9.4.4 Transconductance Driver Model

The crystal and its load capacitors should be viewed as a transimpedance element, whereby a current applied to one terminal generates a voltage at the other. The transconductance amplifier in BlueCore3-ROM uses the voltage at its input, XTAL_IN, to generate a current at its output, XTAL_OUT. Therefore, the circuit will oscillate if the transconductance, transimpedance product is greater than unity. For sufficient oscillation amplitude, the product should be greater than 3. The transconductance required for oscillation is defined by the following relationship:

$$g_m > \frac{3(C_{t1} + C_{trim})(C_{t2} + C_{trim})}{(2\pi F_x)^2 R_m ((C_0 + C_{int})(C_{t1} + C_{t2} + 2C_{trim}) + (C_{t1} + C_{trim})(C_{t2} + C_{trim}))^2}$$

Equation 9.5: Transconductance Required for Oscillation

BlueCore3-ROM guarantees a transconductance value of at least 2mA/V at maximum drive level.

Notes:

More drive strength is required for higher frequency crystals, higher loss crystals (larger R_m) or higher capacitance loading.

Optimum drive level is attained when the level at XTAL_IN is approximately 1V pk-pk. The drive level is determined by the crystal driver transconductance, by setting the Persistent Store KEY_XTAL_LVL (0x241).

9.4.5 Negative Resistance Model

An alternative representation of the crystal and its load capacitors is a frequency dependent resistive element. The driver amplifier may be considered as a circuit that provides negative resistance. For oscillation, the value of the negative resistance must be greater than that of the crystal circuit equivalent resistance. Although the BlueCore3-ROM crystal driver circuit is based on a transimpedance amplifier, an equivalent negative resistance may be calculated for it with the following formula in Equation 9.6:

$$R_{neg} > \frac{3(C_{t1} + C_{trim})(C_{t2} + C_{trim})}{g_m (2\pi F_x)^2 (C_0 + C_{int}) ((C_{t1} + C_{t2} + 2C_{trim}) + (C_{t1} + C_{trim})(C_{t2} + C_{trim}))^2}$$

Equation 9.6: Equivalent Negative Resistance

This formula shows the negative resistance of the BlueCore3-ROM driver as a function of its drive strength.

The value of the driver negative resistance may be easily measured by placing an additional resistance in series with the crystal. The maximum value of this resistor (oscillation occurs) is the equivalent negative resistance of the oscillator.

	Min	Typ	Max
Frequency	8MHz	16MHz	32MHz
Initial Tolerance	-	±25ppm	-
Pullability	-	±20ppm/pF	-

Table 9.6: Crystal Oscillator Specification

9.4.6 Crystal PS Key Settings

See tables in Section 9.3.5.

9.4.7 Crystal Oscillator Characteristics

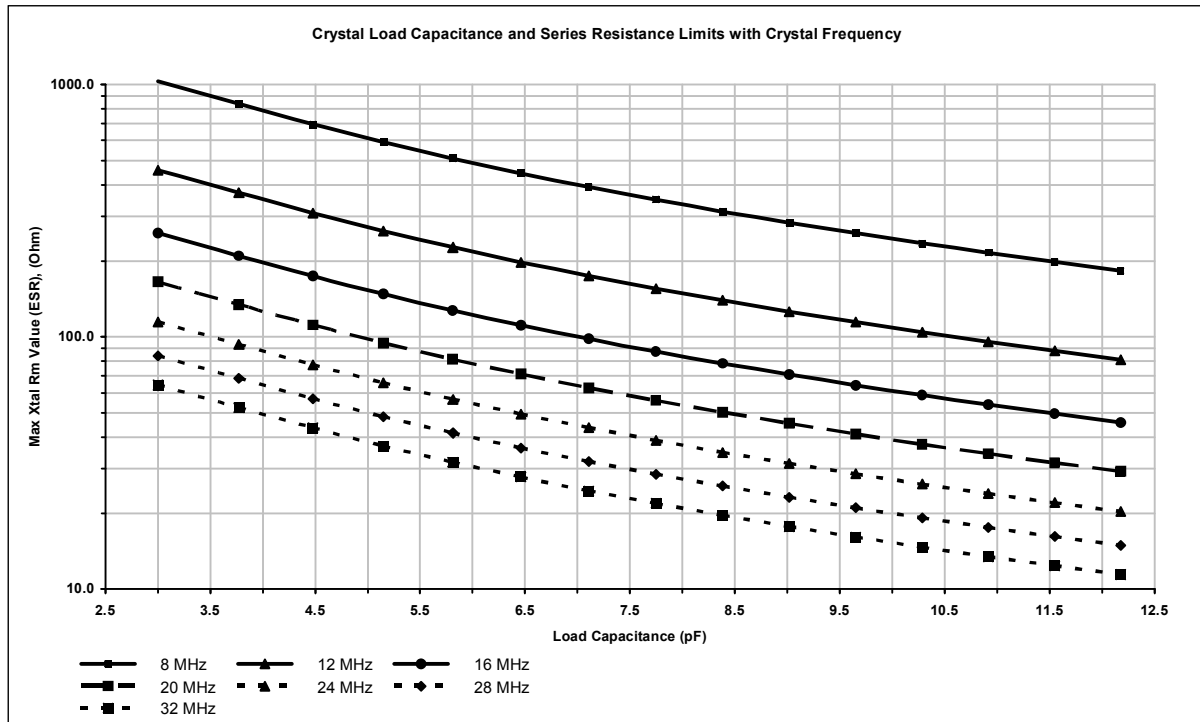

Figure 9.16: Crystal Load Capacitance and Series Resistance Limits with Crystal Frequency

Note:

Graph shows results for BlueCore3-ROM crystal driver at maximum drive level.

Conditions:

$C_{trim} = 3.4\text{pF}$ centre value

Crystal $C_o = 2\text{pF}$

Transconductance setting = 2mA/V

Loop gain = 3

$C_{t1}/C_{t2} = 3$

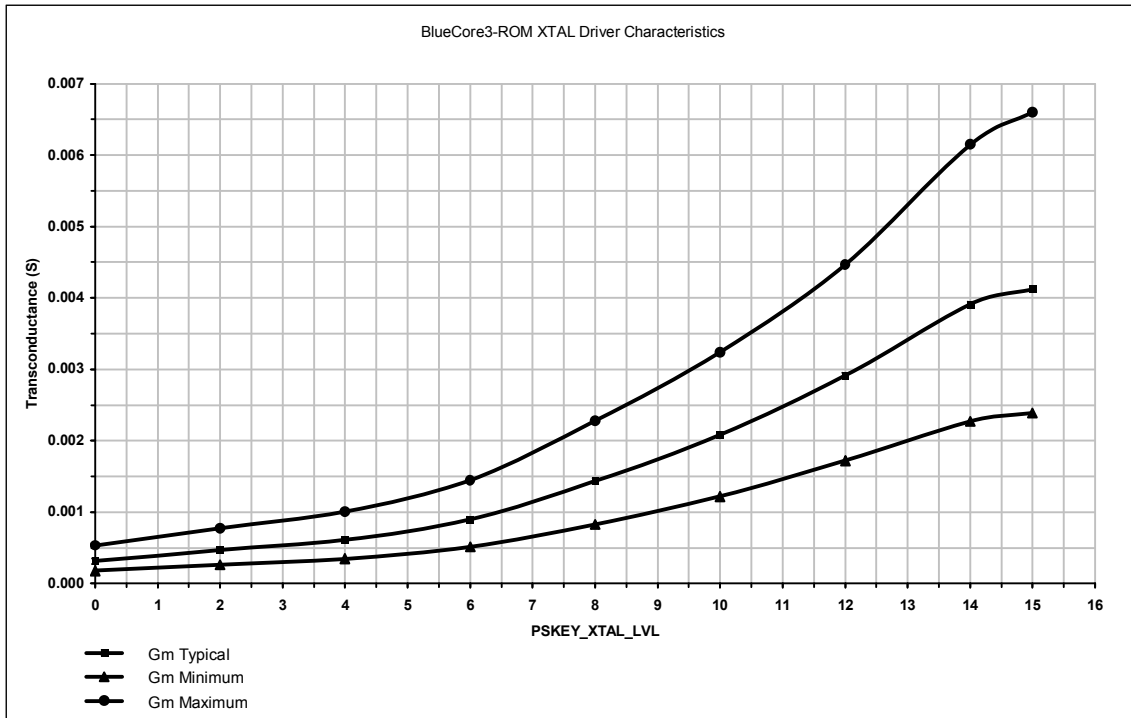

Figure 9.17: Crystal Driver Transconductance vs. Driver Level Register Setting

Note:

Drive level is set by Persistent Store Key PSKEY_XTAL_LVL (0x241).

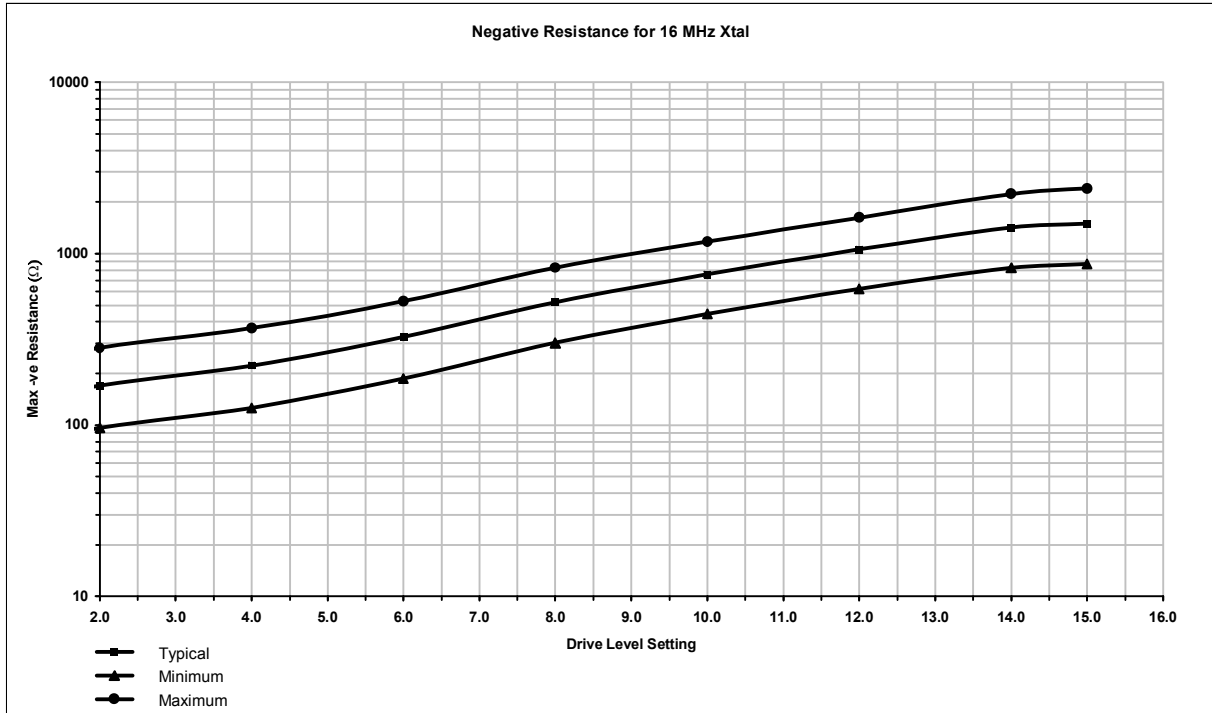

Figure 9.18: Crystal Driver Negative Resistance as a Function of Drive Level Setting

Crystal parameters:

Crystal frequency 16MHz (Please refer to your software build release note for frequencies supported);

Crystal $C_0 = 0.75\text{pF}$

Circuit parameters:

$C_{\text{trim}} = 8\text{pF}$, maximum value

$C_{t1}, C_{t2} = 5\text{pF}$ (3.9pF plus 1.1pF stray)

(Crystal total load capacitance 8.5pF)

Note:

This is for a specific crystal and load capacitance.

9.5 UART Interface

BlueCore3-ROM Universal Asynchronous Receiver Transmitter (UART) interface provides a simple mechanism for communicating with other serial devices using the RS232 standard ⁽¹⁾.

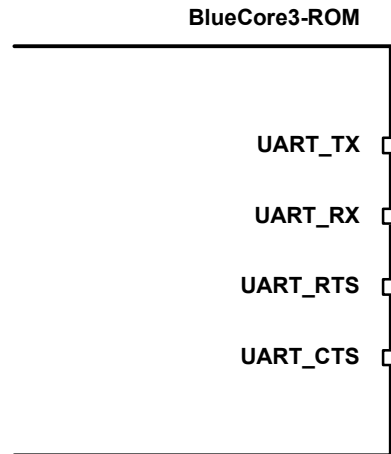

Figure 9.19: Universal Asynchronous Receiver

Four signals are used to implement the UART function, as shown in Figure 9.19. When BlueCore3-ROM is connected to another digital device, UART_RX and UART_TX transfer data between the two devices. The remaining two signals, UART_CTS and UART_RTS, can be used to implement RS232 hardware flow control where both are active low indicators. All UART connections are implemented using CMOS technology and have signalling levels of 0V and VDD_PADS.

UART configuration parameters, such as Baud rate and packet format, are set using BlueCore3-ROM software.

Notes:

In order to communicate with the UART at its maximum data rate using a standard PC, an accelerated serial port adapter card is required for the PC.

⁽¹⁾ Uses RS232 protocol but voltage levels are 0V to VDD_USB, (requires external RS232 transceiver chip)

Parameter		Possible Values
Baud Rate	Minimum	1200 Baud ($\leq 2\%$ Error)
	Maximum	9600 Baud ($\leq 1\%$ Error)
Flow Control		RTS/CTS or None
Parity		None, Odd or Even
Number of Stop Bits		1 or 2
Bits per channel		8

Table 9.7: Possible UART Settings

The UART interface is capable of resetting BlueCore3-ROM upon reception of a break signal. A Break is identified by a continuous logic low (0V) on the UART_RX terminal, as shown in Figure 9.20. If t_{BRK} is longer than the value, defined by the PS Key PSKEY_HOST_IO_UART_RESET_TIMEOUT, (0x1a4), a reset will occur. This feature allows a host to initialise the system to a known state. Also, BlueCore3-ROM can emit a Break character that may be used to wake the Host.



Figure 9.20: Break Signal

Note:

The DFU boot loader must be loaded into the Flash device before the UART or USB interfaces can be used. This initial flash programming can be done via the SPI.

Table 9.8 shows a list of commonly used Baud rates and their associated values for the Persistent Store Key PSKEY_UART_BAUD_RATE (0x204). There is no requirement to use these standard values. Any Baud rate within the supported range can be set in the Persistent Store Key according to the formula in Equation 9.7.

$$\text{Baud Rate} = \frac{\text{PSKEY_UART_BAUD_RATE}}{0.004096}$$

Equation 9.7: Baud Rate

Baud Rate	Persistent Store Value		Error
	Hex	Dec	
1200	0x0005	5	1.73%
2400	0x000a	10	1.73%
4800	0x0014	20	1.73%
9600	0x0027	39	-0.82%
19200	0x004f	79	0.45%
38400	0x009d	157	-0.18%
57600	0x00ec	236	0.03%
76800	0x013b	315	0.14%
115200	0x01d8	472	0.03%
230400	0x03b0	944	0.03%
460800	0x075f	1887	-0.02%
921600	0x0ebf	3775	0.00%
1382400	0x161e	5662	-0.01%

Table 9.8: Standard Baud Rates

9.5.1 UART Bypass

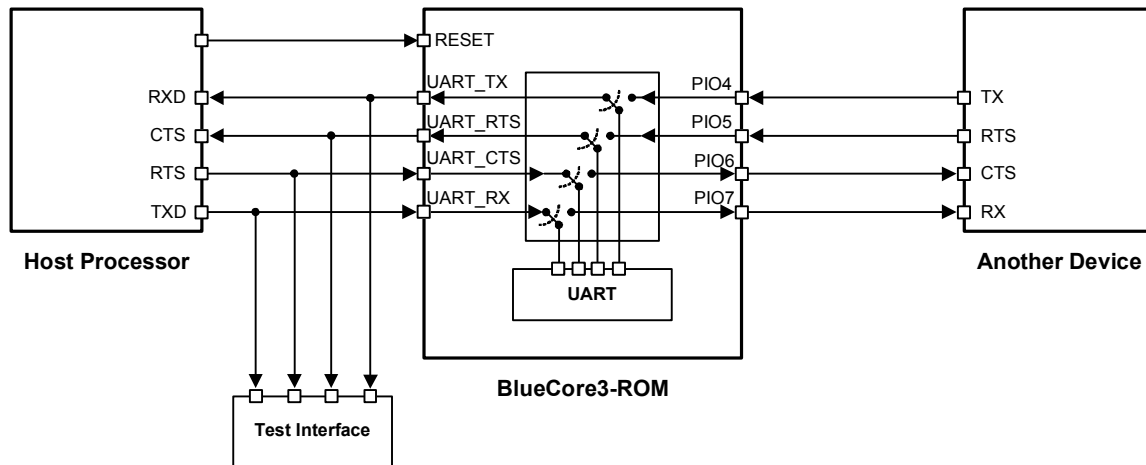

Figure 9.21: UART Bypass Architecture

9.5.2 UART Configuration while RESET is Active

The UART interface for BlueCore3-ROM while the chip is being held in reset is tri-state. This will allow the user to daisy chain devices onto the physical UART bus. The constraint on this method is that any devices connected to this bus must tri-state when BlueCore3-ROM reset is de-asserted and the firmware begins to run.

9.5.3 UART Bypass Mode

Alternatively, for devices that do not tri-state the UART bus, the UART bypass mode on BlueCore3-ROM can be used. The default state of BlueCore3-ROM after reset is de-asserted is for the host UART bus to be connected to the BlueCore3-ROM UART, thereby allowing communication to BlueCore3-ROM via the UART.

In order to apply the UART bypass mode, a BCCMD command will be issued to BlueCore3-ROM upon this, it will switch the bypass to PIO[7:4] as shown in Figure 9.21. Once the bypass mode has been invoked, BlueCore3-ROM will enter the deep sleep state indefinitely.

In order to re-establish communication with BlueCore3-ROM, the chip must be reset so that the default configuration takes affect.

It is important for the host to ensure a clean Bluetooth disconnection of any active links before the bypass mode is invoked. Therefore it is not possible to have active Bluetooth links while operating the bypass mode.

9.5.4 Current Consumption in UART Bypass Mode

The current consumption for a device in UART Bypass Mode is equal to the values quoted for a device in standby mode.

9.6 USB Interface

BlueCore3-ROM devices contain a full speed (12Mbits/s) USB interface that is capable of driving a USB cable directly. No external USB transceiver is required. The device operates as a USB peripheral, responding to requests from a master host controller such as a PC. Both the OHCI and the UHCI standards are supported. The set of USB endpoints implemented can behave as specified in the USB section of the Bluetooth specification v1.2 or alternatively can appear as a set of endpoints appropriate to USB audio devices such as speakers.

As USB is a Master/Slave oriented system (in common with other USB peripherals), BlueCore3-ROM only supports USB Slave operation.

9.6.1 USB Data Connections

The USB data lines emerge as pins USB_DP and USB_DN. These terminals are connected to the internal USB I/O buffers of the BlueCore3-ROM and therefore have a low output impedance. To match the connection to the characteristic impedance of the USB cable, resistors must be placed in series with USB_DP / USB_DN and the cable.

9.6.2 USB Pull-Up Resistor

BlueCore3-ROM features an internal USB pull-up resistor. This pulls the USB_DP pin weakly high when BlueCore3-ROM is ready to enumerate. It signals to the PC that it is a full speed (12Mbit/s) USB device.

The USB internal pull-up is implemented as a current source, and is compliant with Section 7.1.5 of the USB specification v1.2. The internal pull-up pulls USB_DP high to at least 2.8V when loaded with a $15k\Omega \pm 5\%$ pull-down resistor (in the hub/host) when $VDD_PADS=3.1V$. This presents a Thevenin resistance to the host of at least 900Ω . Alternatively, an external $1.5k\Omega$ pull-up resistor can be placed between a PIO line and D+ on the USB cable. The firmware must be alerted to which mode is used by setting PS Key PSKEY_USB_PIO_PULLUP appropriately. The default setting uses the internal pull-up resistor.

9.6.3 Power Supply

The USB specification dictates that the minimum output high voltage for USB data lines is 2.8V. To safely meet the USB specification, the voltage on the VDD_USB supply terminals must be an absolute minimum of 3.1V. CSR recommends 3.3V for optimal USB signal quality.

9.6.4 Self Powered Mode

In self powered mode, the circuit is powered from its own power supply and not from the VBUS (5V) line of the USB cable. It draws only a small leakage current (below 0.5mA) from VBUS on the USB cable. This is the easier mode for which to design for, as the design is not limited by the power that can be drawn from the USB hub or root port. However, it requires that VBUS be connected to BlueCore3-ROM via a resistor network (R_{vb1} and R_{vb2}), so BlueCore3-ROM can detect when VBUS is powered up. BlueCore3-ROM will not pull USB_DP high when VBUS is off.

Self powered USB designs (powered from a battery or PSU) must ensure that a PIO line is allocated for USB pull-up purposes. A 1.5K 5% pull-up resistor between USB_DP and the selected PIO line should be fitted to the design. Failure to fit this resistor may result in the design failing to be USB compliant in self powered mode. The internal pull-up in BlueCore is only suitable for bus powered USB devices i.e. dongles.

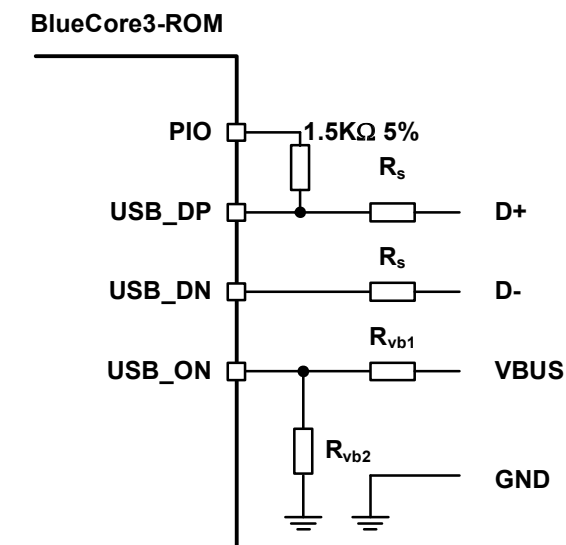

Figure 9.22: USB Connections for Self Powered Mode

The terminal marked USB_ON can be any free PIO pin. The PIO pin selected must be registered by setting PSKEY_USB_PIO_VBUS to the corresponding pin number.

9.6.5 Bus Powered Mode

In bus powered mode the application circuit draws its current from the 5V VBUS supply on the USB cable. BlueCore3-ROM negotiates with the PC during the USB enumeration stage about how much current it is allowed to consume.

For Class 2 Bluetooth applications, CSR recommends that the regulator used to derive 3.3V from VBUS is rated at 100mA average current and should be able to handle peaks of 120mA without foldback or limiting. In bus powered mode, BlueCore3-ROM requests 100mA during enumeration.

For Class 1 Bluetooth applications, the USB power descriptor should be altered to reflect the amount of power required. This is accomplished by setting the PS Key PSKEY_USB_MAX_POWER (0x2c6). This is higher than for a Class 2 application due to the extra current drawn by the Transmit RF PA.

When selecting a regulator, be aware that VBUS may go as low as 4.4V. The inrush current (when charging reservoir and supply decoupling capacitors) is limited by the USB specification (see USB specification v1.1, Section 7.2.4.1). Some applications may require soft start circuitry to limit inrush current if more than 10 μ F is present between VBUS and GND.

The 5V VBUS line emerging from a PC is often electrically noisy. As well as regulation down to 3.3V and 1.8V, applications should include careful filtering of the 5V line to attenuate noise that is above the voltage regulator bandwidth. Excessive noise on the 1.8V supply to the analogue supply pins of BlueCore3-ROM will result in reduced receive sensitivity and a distorted RF transmit signal.

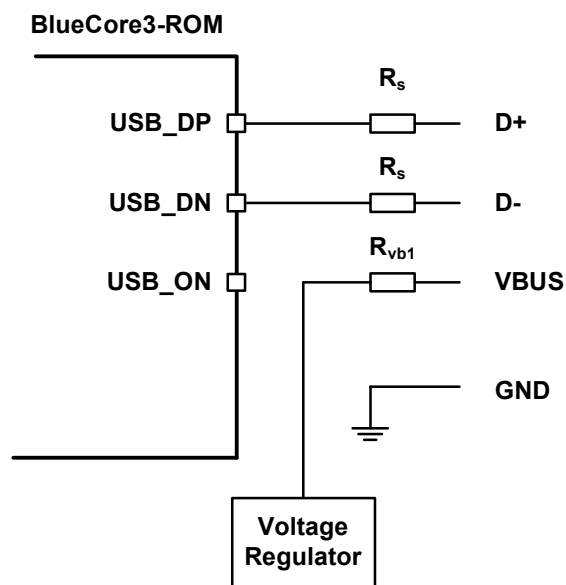

Figure 9.23: USB Connections for Bus Powered Mode

Note:

USB_ON is shared with BlueCore3-ROM PIO terminals

Identifier	Value	Function
R_s	27 Ω nominal	Impedance matching to USB cable
R_{vb1}	22k Ω 5%	VBUS ON sense divider
R_{vb2}	47k Ω 5%	VBUS ON sense divider

Table 9.9: USB Interface Component Values

9.6.6 Suspend Current

All USB devices must permit the USB controller to place them in a USB Suspend mode. While in USB Suspend, bus powered devices must not draw more than 0.5mA from USB VBUS (self powered devices may draw more than 0.5mA from their own supply). This current draw requirement prevents operation of the radio by bus powered devices during USB Suspend.

The voltage regulator circuit itself should draw only a small quiescent current (typically less than 100 μ A) to ensure adherence to the suspend current requirement of the USB specification. This is not normally a problem with modern regulators. Ensure that external LEDs and/or amplifiers can be turned off by BlueCore3-ROM. The entire circuit must be able to enter the suspend mode. (For more details on USB Suspend, see separate CSR documentation).

9.6.7 Detach and Wake_Up Signalling

BlueCore3-ROM can provide out-of-band signalling to a host controller by using the control lines called 'USB_DETACH' and 'USB_WAKE_UP'. These are outside the USB specification (no wires exist for them inside the USB cable), but can be useful when embedding BlueCore3-ROM into a circuit where no external USB is visible to the user. Both control lines are shared with PIO pins and can be assigned to any PIO pin by setting the PS Keys PSKEY_USB_PIO_DETACH and PSKEY_USB_PIO_WAKEUP to the selected PIO number.

USB_DETACH is an input which, when asserted high, causes BlueCore3-ROM to put USB_DN and USB_DP in a high impedance state and turned off the pull-up resistor on DP. This detaches the device from the bus and is logically equivalent to unplugging the device. When USB_DETACH is taken low, BlueCore3-ROM will connect back to USB and await enumeration by the USB host.

USB_WAKE_UP is an active high output (used only when USB_DETACH is active) to wake up the host and allow USB communication to recommence. It replaces the function of the software USB WAKE_UP message (which runs over the USB cable), and cannot be sent while BlueCore3-ROM is effectively disconnected from the bus.

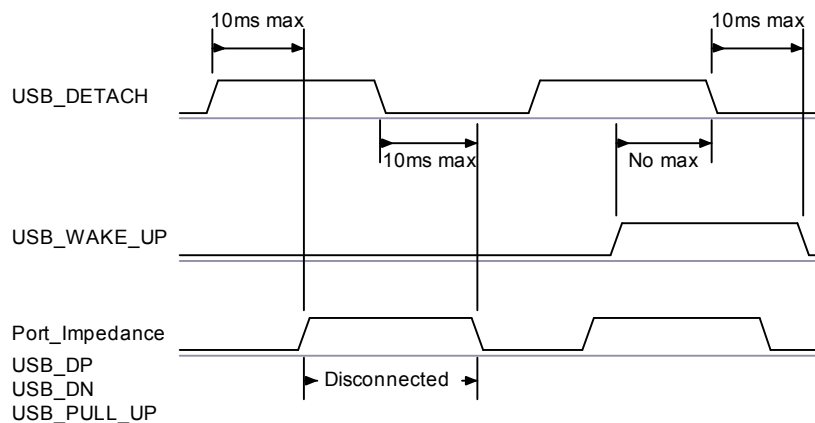

Figure 9.24: USB_DETACH and USB_WAKE_UP Signal

9.6.8 USB Driver

A USB Bluetooth device driver is required to provide a software interface between BlueCore3-ROM and Bluetooth software running on the host computer. Suitable drivers are available from www.csrsupport.com.

9.6.9 USB 1.1 Compliance

BlueCore3-ROM is qualified to the USB specification v1.1, details of which are available from <http://www.usb.org>. The specification contains valuable information on aspects such as PCB track impedance, supply inrush current and product labelling.

Although BlueCore3-ROM meets the USB specification, CSR cannot guarantee that an application circuit designed around the chip is USB compliant. The choice of application circuit, component choice and PCB layout all affect USB signal quality and electrical characteristics. The information in this document is intended as a guide and should be read in association with the USB specification, with particular attention being given to Chapter 7. Independent USB qualification must be sought before an application is deemed USB compliant and can bear the USB logo. Such qualification can be obtained from a USB plugfest or from an independent USB test house.

Terminals USB_DP and USB_DN adhere to the USB specification 2.0 (Chapter 7) electrical requirements.

9.6.10 USB 2.0 Compatibility

BlueCore3-ROM is compatible with USB v2.0 host controllers; under these circumstances the two ends agree the mutually acceptable rate of 12Mbits/s according to the USB v2.0 specification.

9.7 Serial Peripheral Interface

BlueCore3-ROM uses 16-bit data and 16-bit address serial peripheral interface, where transactions may occur when the internal processor is running or is stopped. This section details the considerations required when interfacing to BlueCore3-ROM via the four dedicated serial peripheral interface terminals. Data may be written or read one word at a time or the auto increment feature may be used to access blocks.

9.7.1 Instruction Cycle

The BlueCore3-ROM is the slave and receives commands on SPI_MOSI and outputs data on SPI_MISO. The instruction cycle for a SPI transaction is shown in Table 9.10.

1	Reset the SPI interface	Hold SPI_CSB high for two SPI_CLK cycles
2	Write the command word	Take SPI_CSB low and clock in the 8 bit command
3	Write the address	Clock in the 16-bit address word
4	Write or read data words	Clock in or out 16-bit data word(s)
5	Termination	Take SPI_CSB high

Table 9.10: Instruction Cycle for an SPI Transaction

With the exception of reset, SPI_CSB must be held low during the transaction. Data on SPI_MOSI is clocked into the BlueCore3-ROM on the rising edge of the clock line SPI_CLK. When reading, BlueCore3-ROM will reply to the master on SPI_MISO with the data changing on the falling edge of the SPI_CLK. The master provides the clock on SPI_CLK. The transaction is terminated by taking SPI_CSB high.

Sending a command word and the address of a register for every time it is to be read or written is a significant overhead, especially when large amounts of data are to be transferred. To overcome this BlueCore3-ROM offers increased data transfer efficiency via an auto increment operation. To invoke auto increment, SPI_CSB is kept low, which auto increments the address, while providing an extra 16 clock cycles for each extra word to be written or read.

9.7.2 Writing to BlueCore3-ROM

To write to BlueCore3-ROM, the 8-bit write command (00000010) is sent first (C[7:0]) followed by a 16-bit address (A[15:0]). The next 16-bits (D[15:0]) clocked in on SPI_MOSI are written to the location set by the address (A). Thereafter for each subsequent 16-bits clocked in, the address (A) is incremented and the data written to consecutive locations until the transaction terminates when SPI_CSB is taken high.

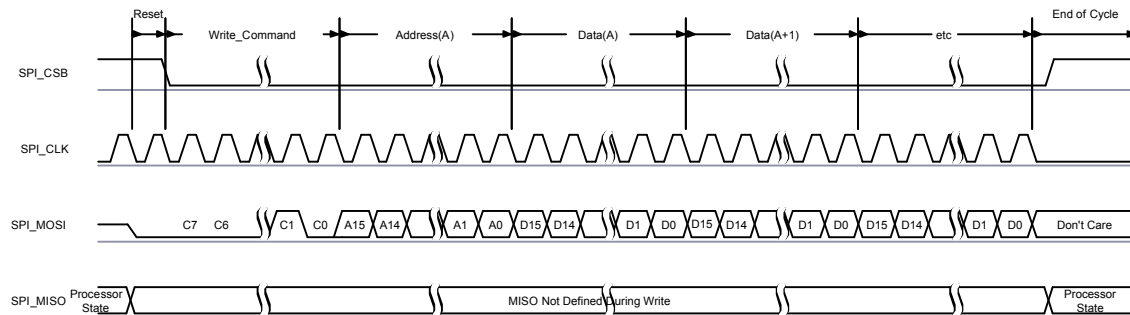

Figure 9.25: Write Operation

9.7.3 Reading from BlueCore3-ROM

Reading from BlueCore3-ROM is similar to writing to it. An 8-bit read command (00000011) is sent first (C[7:0]), followed by the address of the location to be read (A[15:0]). BlueCore3-ROM then outputs on SPI_MISO a check word during T[15:0] followed by the 16-bit contents of the addressed location during bits D[15:0].

The check word is composed of {command, address [15:8]}. The check word may be used to confirm a read operation to a memory location. This overcomes the problems encountered with typical serial peripheral interface slaves, whereby it is impossible to determine whether the data returned by a read operation is valid data or the result of the slave device not responding.

If SPI_CSB is kept low, data from consecutive locations is read out on SPI_MISO for each subsequent 16 clocks, until the transaction terminates when SPI_CSB is taken high.

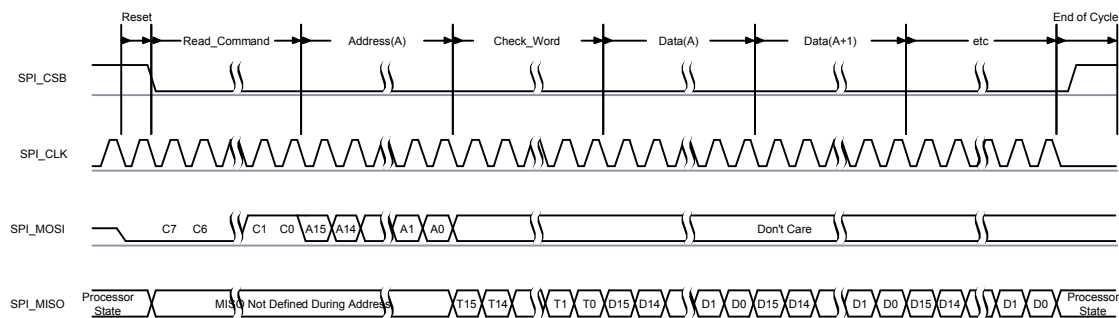

Figure 9.26: Read Operation

9.7.4 Multi Slave Operation

BlueCore3-ROM should not be connected in a multi slave arrangement by simple parallel connection of slave MISO lines. When BlueCore3-ROM is deselected (SPI_CSB = 1), the SPI_MISO line does not float, instead, BlueCore3-ROM outputs 0 if the processor is running or 1 if it is stopped.

9.7.5 PCM CODEC Interface

Pulse Code Modulation (PCM) is a standard method used to digitise human voice patterns for transmission over digital communication channels. Through its PCM interface, BlueCore3-ROM has hardware support for continual transmission and reception of PCM data, thus reducing processor overhead for wireless headset applications. BlueCore3-ROM offers a bi directional digital audio interface that routes directly into the baseband layer of the on chip firmware. It does not pass through the HCI protocol layer.

Hardware on BlueCore3-ROM allows the data to be sent to and received from a SCO connection.

Up to three SCO connections can be supported by the PCM interface at any one time⁽¹⁾.

BlueCore3-ROM can operate as the PCM interface Master generating an output clock of 128, 256 or 512kHz. When configured as PCM interface slave it can operate with an input clock up to 2048kHz. BlueCore3-ROM is compatible with a variety of clock formats, including Long Frame Sync, Short Frame Sync and GCI timing environments.

It supports 13 or 16-bit linear, 8-bit μ -law or A-law companded sample formats at 8ksamples/s and can receive and transmit on any selection of three of the first four slots following PCM_SYNC. The PCM configuration options are enabled by setting the PS Key PS_KEY_PCM_CONFIG (0x1b3).

BlueCore3-ROM interfaces directly to PCM audio devices including the following:

- Qualcomm MSM 3000 series and MSM 5000 series CDMA baseband devices
- OKI MSM7705 four channel A-law and μ -law CODEC
- Motorola MC145481 8-bit A-law and μ -law CODEC
- Motorola MC145483 13-bit linear CODEC
- STW 5093 and 5094 14-bit linear CODECs
- BlueCore3-ROM is also compatible with the Motorola SSI™ interface

Note:

- ⁽¹⁾ Subject to firmware support, contact CSR for current status.

9.7.6 PCM Interface Master/Slave

When configured as the Master of the PCM interface, BlueCore3-ROM generates PCM_CLK and PCM_SYNC.

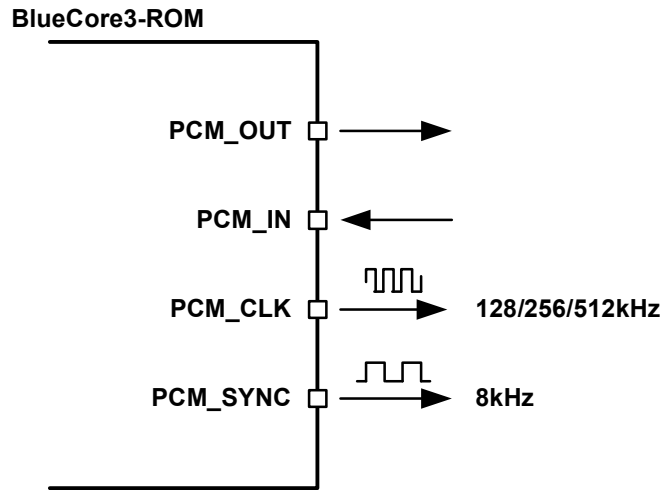

Figure 9.27: BlueCore3-ROM as PCM Interface Master

When configured as the Slave of the PCM interface, BlueCore3-ROM accepts PCM_CLK rates up to 2048kHz.

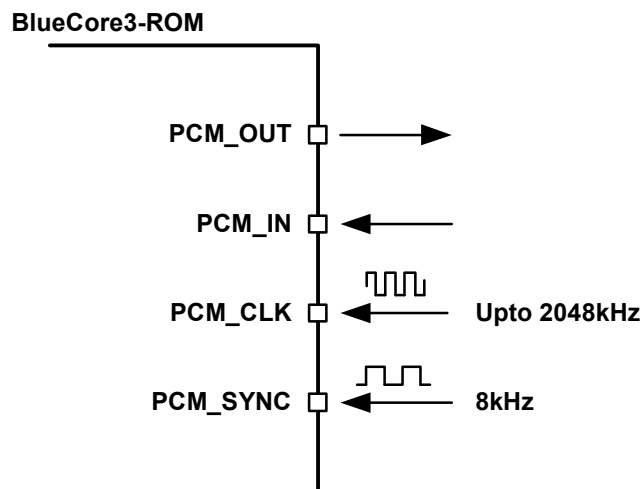

Figure 9.28: BlueCore3-ROM as PCM Interface Slave

9.7.7 Long Frame Sync

Long Frame Sync is the name given to a clocking format that controls the transfer of PCM data words or samples. In Long Frame Sync, the rising edge of PCM_SYNC indicates the start of the PCM word. When BlueCore3-ROM is configured as PCM Master, generating PCM_SYNC and PCM_CLK, then PCM_SYNC is 8-bits long. When BlueCore3-ROM is configured as PCM Slave, PCM_SYNC may be from two consecutive falling edges of PCM_CLK to half the PCM_SYNC rate, i.e. 62.5µs long.

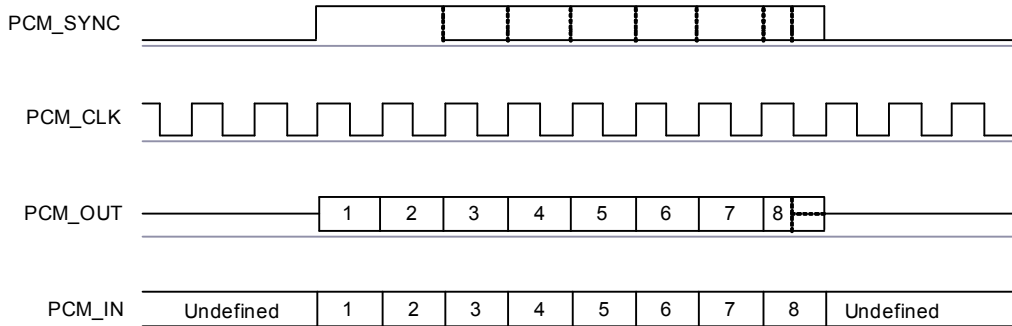

Figure 9.29: Long Frame Sync (Shown with 8-bit Companded Sample)

BlueCore3-ROM samples PCM_IN on the falling edge of PCM_CLK and transmits PCM_OUT on the rising edge. PCM_OUT may be configured to be high impedance on the falling edge of PCM_CLK in the LSB position or on the rising edge.

9.7.8 Short Frame Sync

In Short Frame Sync the falling edge of PCM_SYNC indicates the start of the PCM word. PCM_SYNC is always one clock cycle long.

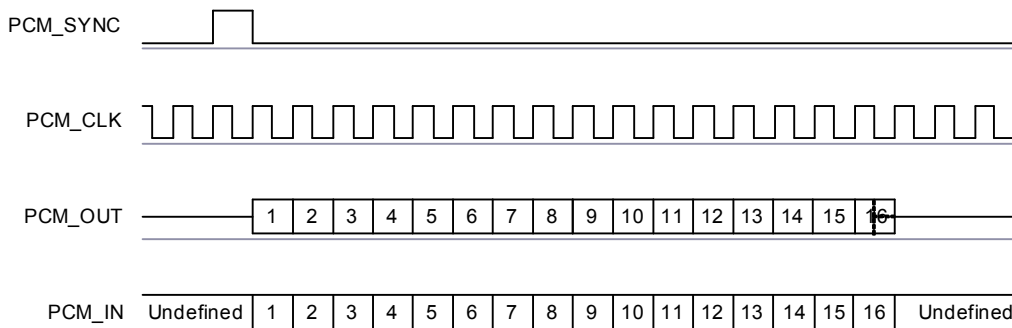

Figure 9.30: Short Frame Sync (Shown with 16-bit Sample)

As with Long Frame Sync, BlueCore3-ROM samples PCM_IN on the falling edge of PCM_CLK and transmits PCM_OUT on the rising edge. PCM_OUT may be configured to be high impedance on the falling edge of PCM_CLK in the LSB position or on the rising edge.

9.7.9 Multi Slot Operation

More than one SCO connection over the PCM interface is supported using multiple slots. Up to three SCO connections can be carried over any of the first four slots.

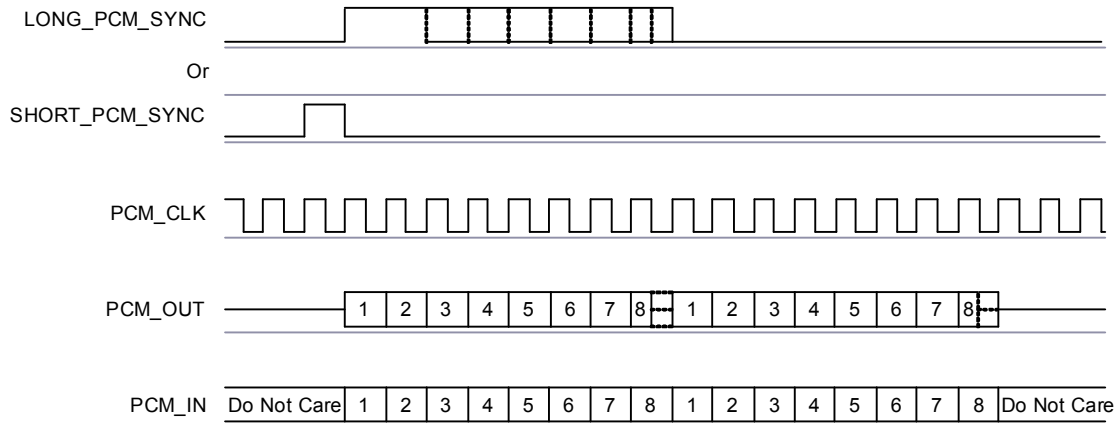

Figure 9.31: Multi Slot Operation with Two Slots and 8-bit Companded Samples

9.7.10 GCI Interface

BlueCore3-ROM is compatible with the General Circuit Interface, a standard synchronous 2B+D ISDN timing interface. The two 64Kbps B channels can be accessed when this mode is configured.

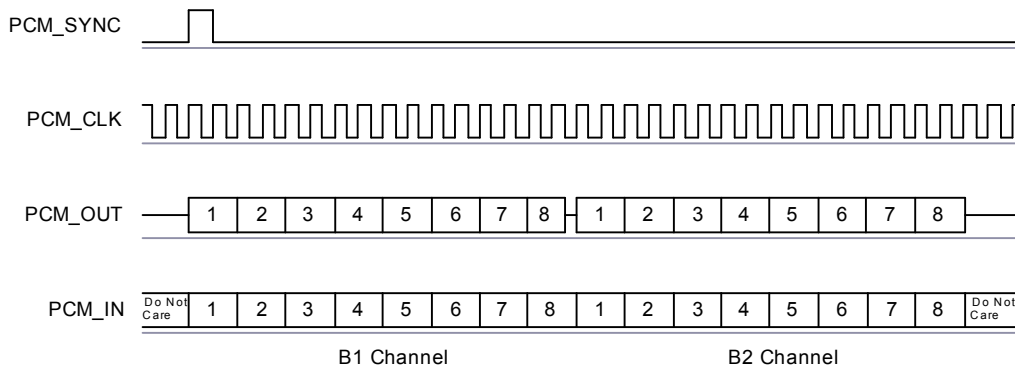

Figure 9.32: GCI Interface

The start of frame is indicated by the rising edge of PCM_SYNC and runs at 8kHz. With BlueCore3-ROM in Slave mode, the frequency of PCM_CLK can be up to 4.096MHz.

9.7.11 Slots and Sample Formats

BlueCore3-ROM can receive and transmit on any selection of the first four slots following each sync pulse. Slot durations can be either 8 or 16 clock cycles. Durations of 8 clock cycles may only be used with 8-bit sample formats. Durations of 16 clocks may be used with 8, 13 or 16-bit sample formats.

BlueCore3-ROM supports 13-bit linear, 16-bit linear and 8-bit μ -law or A-law sample formats. The sample rate is 8ksamples/s. The bit order may be little or big endian. When 16-bit slots are used, the 3 or 8 unused bits in each slot may be filled with sign extension, padded with zeros or a programmable 3-bit audio attenuation compatible with some Motorola CODECs.

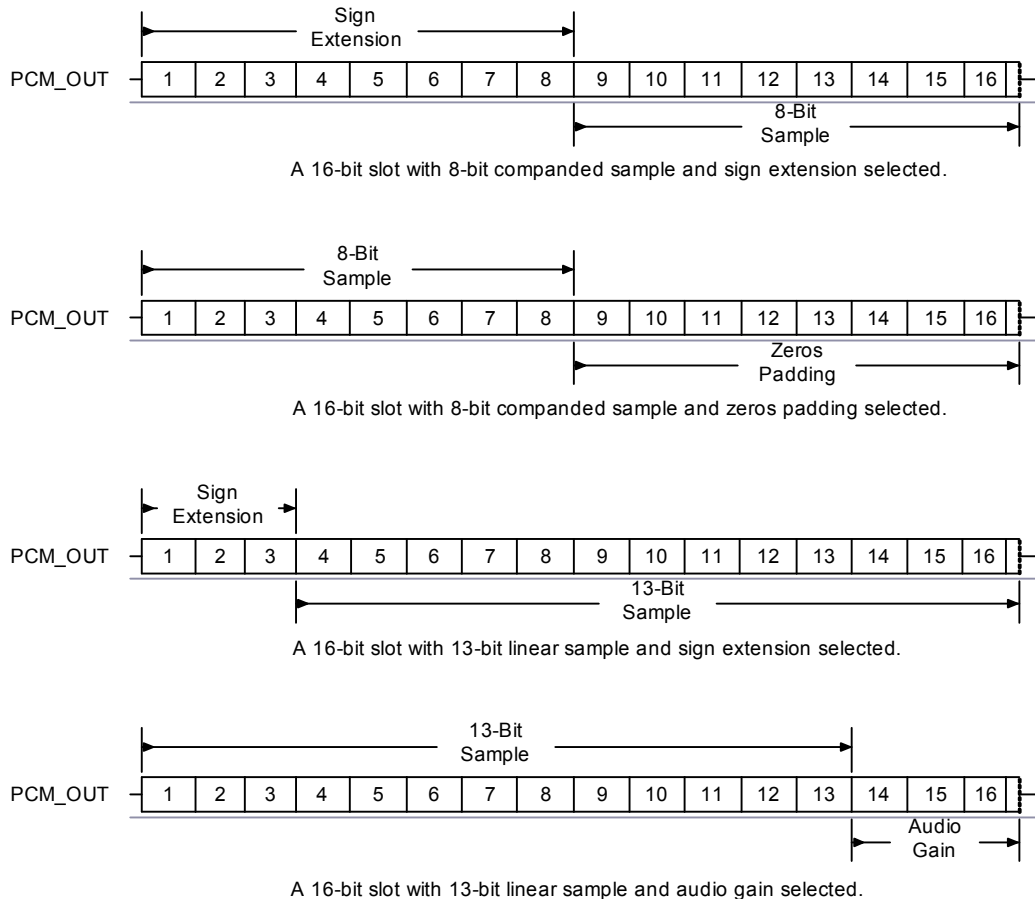

Figure 9.33: 16-Bit Slot Length and Sample Formats

9.7.12 Additional Features

BlueCore3-ROM has a mute facility that forces PCM_OUT to be 0. In Master mode, PCM_SYNC may also be forced to 0 while keeping PCM_CLK running which some CODECS use to control power down.

9.7.13 PCM Timing Information

Symbol	Parameter		Min	Typ	Max	Unit
f_{mclk}	PCM_CLK frequency	4MHz DDS generation. Selection of frequency is programmable, see Table 9.13	-	128 256 512	-	kHz
		48MHz DDS generation. Selection of frequency is programmable, see Table 9.14 and Section 9.7.15	2.9		-	kHz
-	PCM_SYNC frequency		-	8		kHz
$t_{mclkh}^{(1)}$	PCM_CLK high	4MHz DDS generation	980	-	-	ns
$t_{mckl}^{(1)}$	PCM_CLK low	4MHz DDS generation	730	-		ns
-	PCM_CLK jitter	48MHz DDS generation			21	ns pk-pk
$t_{dmclksynch}$	Delay time from PCM_CLK high to PCM_SYNC high		-	-	20	ns
$t_{dmclkpout}$	Delay time from PCM_CLK high to valid PCM_OUT		-	-	20	ns
$t_{dmcklsyncl}$	Delay time from PCM_CLK low to PCM_SYNC low (Long Frame Sync only)		-	-	20	ns
$t_{dmckhsyncl}$	Delay time from PCM_CLK high to PCM_SYNC low		-	-	20	ns
$t_{dmcklpoutz}$	Delay time from PCM_CLK low to PCM_OUT high impedance		-	-	20	ns
$t_{dmckhpoutz}$	Delay time from PCM_CLK high to PCM_OUT high impedance		-	-	20	ns
$t_{supinckl}$	Set-up time for PCM_IN valid to PCM_CLK low		30	-	-	ns
$t_{hpinckl}$	Hold time for PCM_CLK low to PCM_IN invalid		10	-	-	ns

Table 9.11: PCM Master Timing

Note:

- ⁽¹⁾ Assumes normal system clock operation. Figures will vary during low power modes, when system clock speeds are reduced.

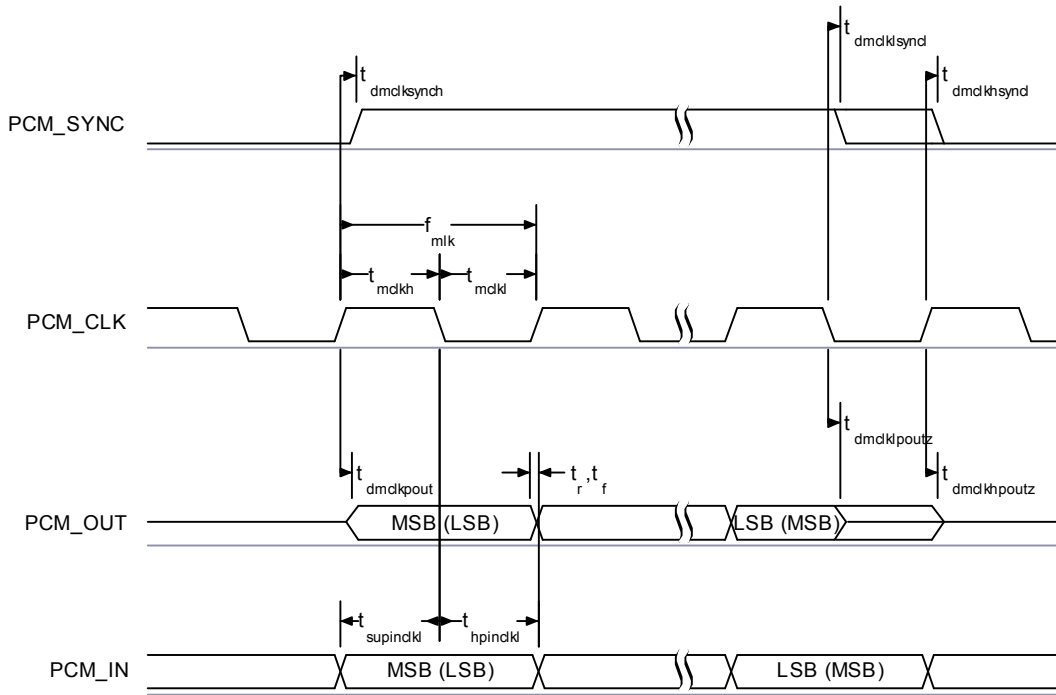

Figure 9.34: PCM Master Timing Long Frame Sync

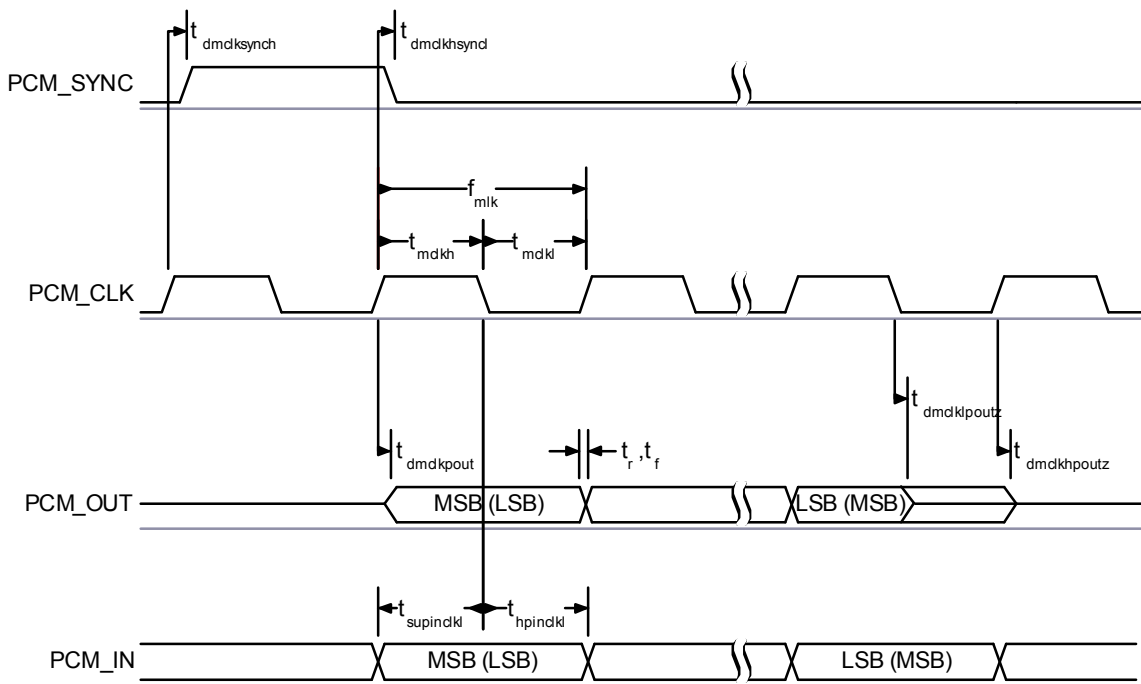

Figure 9.35: PCM Master Timing Short Frame Sync

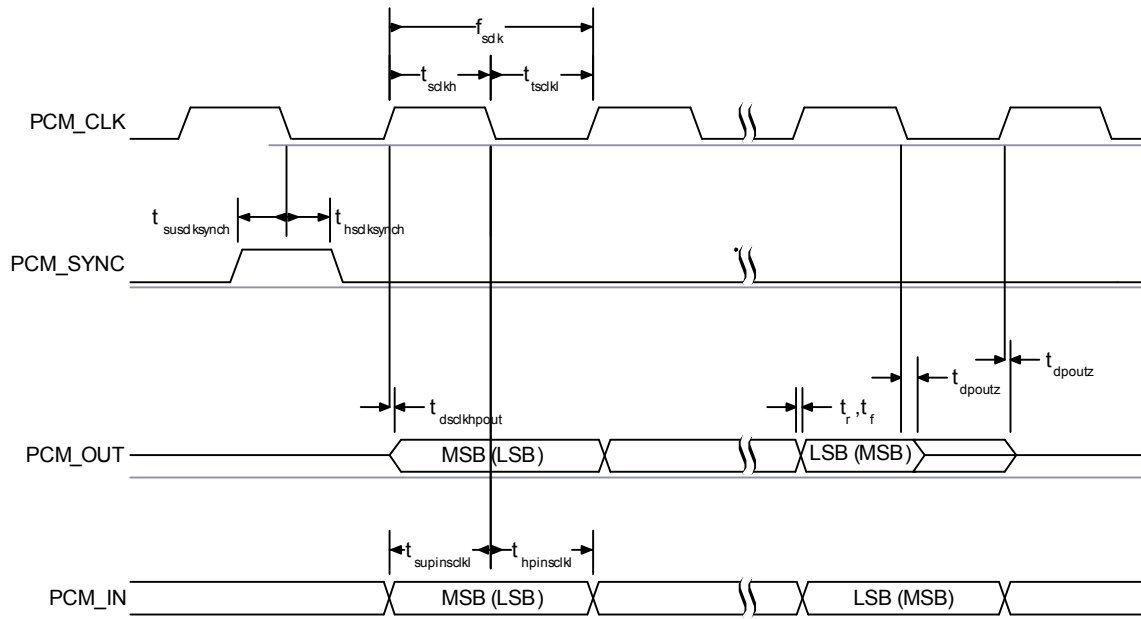

Figure 9.37: PCM Slave Timing Short Frame Sync

9.7.15 PCM_CLK and PCM_SYNC Generation

BlueCore3-ROM has two methods of generating PCM_CLK and PCM_SYNC in master mode. The first is generating these signals by Direct Digital Synthesis (DDS) from BlueCore3-ROM internal 4MHz clock (which is used in BlueCore3-ROM). Using this mode limits PCM_CLK to 128, 256 or 512kHz and PCM_SYNC to 8kHz. The second is generating PCM_CLK and PCM_SYNC by DDS from an internal 48MHz clock which allows a greater range of frequencies to be generated with low jitter but consumes more power. This second method is selected by setting bit '48M_PCM_CLK_GEN_EN' in PSKEY_PCM_CONFIG32.

Note:

The bit 'SLAVE_MODE_EN' should also be set. When in this mode and with long frame sync, the length of PCM_SYNC can be either 8 or 16 cycles of PCM_CLK, determined by 'LONG_LENGTH_SYNC_EN' in PSKEY_PCM_CONFIG32.

The Equation 9.8 describes PCM_CLK frequency when being generated using the internal 48MHz clock:

$$f = \frac{\text{CNT_RATE}}{\text{CNT_LIMIT}} \times 24\text{MHz}$$

Equation 9.8: PCM_CLK Frequency When Being Generated Using the Internal 48MHz clock

The frequency of PCM_SYNC relative to PCM_CLK can be set using following equation:

$$f = \frac{\text{PCM_CLK}}{\text{SYNC_LIMIT} \times 8}$$

Equation 9.9: PCM_SYNC Frequency Relative to PCM_CLK

CNT_RATE, CNT_LIMIT and SYNC_LIMIT are set using PSKEY_PCM_LOW_JITTER_CONFIG. As an example, to generate PCM_CLK at 512kHz with PCM_SYNC at 8kHz, set PSKEY_PCM_LOW_JITTER_CONFIG to 0x08080177.

9.7.16 PCM Configuration

The PCM configuration is set using two PS Keys, PSKEY_PCM_CONFIG32 and PSKEY_PCM_LOW_JITTER_CONFIG. The following tables detail these PS Keys. PSKEY_PCM_CONFIG32. The default for this key is 0x00800000 i.e. first slot following sync is active, 13-bit linear voice format, long frame sync and interface master generating 256kHz PCM_CLK from 4MHz internal clock with no tristating of PCM_OUT. PSKEY_PCM_LOW_JITTER_CONFIG is described in Table 9.14.

Name	Bit Position	Description
-	0	Set to 0.
SLAVE_MODE_EN	1	0 selects Master mode with internal generation of PCM_CLK and PCM_SYNC. 1 selects Slave mode requiring externally generated PCM_CLK and PCM_SYNC. This should be set to 1 if 48M_PCM_CLK_GEN_EN (bit 11) is set.
SHORT_SYNC_EN	2	0 selects long frame sync (rising edge indicates start of frame), 1 selects short frame sync (falling edge indicates start of frame).
-	3	Set to 0.
SIGN_EXTEND_EN	4	0 selects padding of 8 or 13-bit voice sample into a 16-bit slot by inserting extra LSBs, 1 selects sign extension. When padding is selected with 13-bit voice sample, the 3 padding bits are the audio gain setting; with 8-bit samples the 8 padding bits are zeroes.
LSB_FIRST_EN	5	0 transmits and receives voice samples MSB first, 1 uses LSB first.
TX_TRISTATE_EN	6	0 drives PCM_OUT continuously, 1 tri-states PCM_OUT immediately after the falling edge of PCM_CLK in the last bit of an active slot, assuming the next slot is not active.
TX_TRISTATE_RISING_EDGE_EN	7	0 tristates PCM_OUT immediately after the falling edge of PCM_CLK in the last bit of an active slot, assuming the next slot is also not active. 1 tristates PCM_OUT after the rising edge of PCM_CLK.
SYNC_SUPPRESS_EN	8	0 enables PCM_SYNC output when master, 1 suppresses PCM_SYNC whilst keeping PCM_CLK running. Some CODECS utilise this to enter a low power state.
GCI_MODE_EN	9	1 enables GCI mode.
MUTE_EN	10	1 forces PCM_OUT to 0.
48M_PCM_CLK_GEN_EN	11	0 sets PCM_CLK and PCM_SYNC generation via DDS from internal 4 MHz clock, as for BlueCore3-ROM. 1 sets PCM_CLK and PCM_SYNC generation via DDS from internal 48 MHz clock.
LONG_LENGTH_SYNC_EN	12	0 sets PCM_SYNC length to 8 PCM_CLK cycles and 1 sets length to 16 PCM_CLK cycles. Only applies for long frame sync and with 48M_PCM_CLK_GEN_EN set to 1.
-	[20:16]	Set to 0b00000.
MASTER_CLK_RATE	[22:21]	Selects 128 (0b01), 256 (0b00), 512 (0b10) kHz PCM_CLK frequency when master and 48M_PCM_CLK_GEN_EN (bit 11) is low.
ACTIVE_SLOT	[26:23]	Default is '0001'. Ignored by firmware.
SAMPLE_FORMAT	[28:27]	Selects between 13 (0b00), 16 (0b01), 8 (0b10) bit sample with 16 cycle slot duration or 8 (0b11) bit sample with 8 cycle slot duration.

Table 9.13: PSKEY_PCM_CONFIG32 Description

Name	Bit Position	Description
CNT_LIMIT	[12:0]	Sets PCM_CLK counter limit.
CNT_RATE	[23:16]	Sets PCM_CLK count rate.
SYNC_LIMIT	[31:24]	Sets PCM_SYNC division relative to PCM_CLK.

Table 9.14: PSKEY_PCM_LOW_JITTER_CONFIG Description

9.8 I/O Parallel Ports

Fifteen lines of programmable bi-directional input/outputs (I/O) are provided. PIO[11:8] and PIO[3:0] are powered from VDD_PIO. PIO[7:4] are powered from VDD_PADS. AIO [2:0] are powered from VDD_MEM.

PIO lines can be configured through software to have either weak or strong pull-ups or pull-downs. All PIO lines are configured as inputs with weak pull-downs at reset.

PIO[0] and PIO[1] are normally dedicated to RXEN and TXEN respectively, but they are available for general use.

Any of the PIO lines can be configured as interrupt request lines or as wake-up lines from sleep modes. PIO[6] or PIO [2] can be configured as a request line for an external clock source. This is useful when the clock to BlueCore3-ROM is provided from a system application specific integrated circuit (ASIC). Using PSKEY_CLOCK_REQUEST_ENABLE, (0x246) this terminal can be configured to be low when BlueCore3-ROM is in deep sleep and high when a clock is required. The clock must be supplied within 4ms of the rising edge of PIO[6] or PIO[2] to avoid losing timing accuracy in certain Bluetooth operating modes.

BlueCore3-ROM has three general purpose analogue interface pins, AIO[0], AIO[1] and AIO[2]. These are used to access internal circuitry and control signals. One pin is allocated to decoupling for the on-chip bandgap reference voltage, the other two may be configured to provide additional functionality.

Auxiliary functions available via these pins include an 8-bit ADC and an 8-bit DAC. Typically the ADC is used for battery voltage measurement. Signals selectable at these pins include the bandgap reference voltage and a variety of clock signals; 48, 24, 16, 8MHz and the XTAL clock frequency. When used with analogue signals the voltage range is constrained by the analogue supply voltage (1.8V). When configured to drive out digital level signals (clocks) generated from within the analogue part of the device, the output voltage level is determined by VDD_MEM (1.8V).

9.9 I²C Interface

PIO[8:6] can be used to form a Master I²C interface. The interface is formed using software to drive these lines. Therefore it is suited only to relatively slow functions such as driving a dot matrix liquid crystal display (LCD), keyboard scanner or EEPROM.

Notes:

PIO lines need to be pulled-up through 2.2kΩ resistors.

PIO[7:6] dual functions, UART bypass and EEPROM support, therefore devices using an EEPROM cannot support UART bypass mode

For connection to EEPROMs, refer to CSR documentation on I²C EEPROMS for use with BlueCore. This provides information on the type of devices which are currently supported.

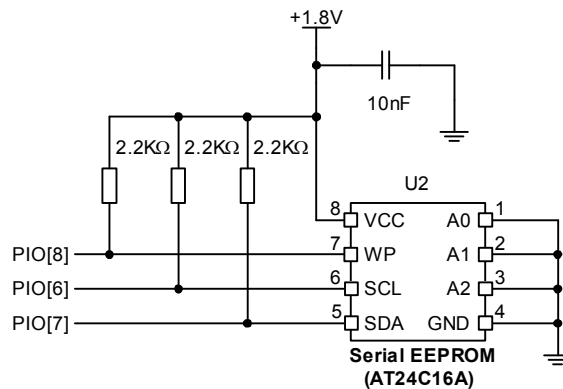

Figure 9.38: Example EEPROM Connection

9.10 TCXO Enable OR Function

An OR function exists for clock enable signals from a host controller and BlueCore3-ROM where either device can turn on the clock without having to wake up the other device. PIO[3] can be used as the Host clock enable input and PIO[2] can be used as the OR output with the TCXO enable signal from BlueCore3-ROM.

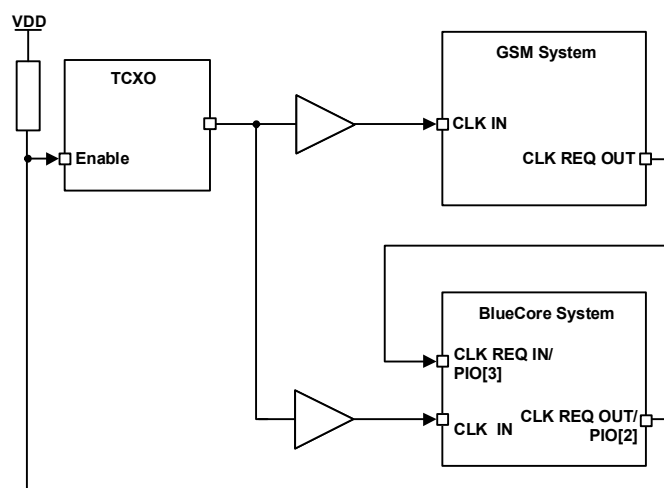

Figure 9.39: Example TXCO Enable OR Function

On reset and up to the time the PIO has been configured, PIO[2] will be tri-stated. Therefore, the developer must ensure that the circuitry connected to this pin is pulled via a 470k resistor to the appropriate power rail. This ensures that the TCXO is oscillating at start up.

9.11 RESET and RESETB

BlueCore3-ROM may be reset from several sources: RESET or RESETB pins, power on reset, a UART break character or via a software configured watchdog timer.

The RESET pin is an active high reset and is internally filtered using the internal low frequency clock oscillator. A reset will be performed between 1.5 and 4.0ms following RESET being active. CSR recommends that RESET is applied for a period greater than 5ms. The RESETB pin is the active low version of RESET and is 'ORed' on-chip with the active high RESET with either causing the reset function.

The power on reset occurs when the VDD_CORE supply falls below typically 1.5V and is released when VDD_CORE rises above typically 1.6V.

At reset the digital I/O pins are set to inputs for bi-directional pins and outputs are tri-stated. The PIOs have weak pull-downs.

Following a reset, BlueCore3-ROM assumes the maximum XTAL_IN frequency which ensures that the internal clocks run at a safe (low) frequency until BlueCore-ROM is configured for the actual XTAL_IN frequency. If no clock is present at XTAL_IN, the oscillator in BlueCore3-ROM free runs, again at a safe frequency.

9.11.1 Pin States on Reset

Table 9.15 shows the pin states of BlueCore3-ROM on reset.

Pin name	State: BlueCore3-ROM
PIO[11:0]	Input with weak pull-down
PCM_OUT	Tri-stated with weak pull-down
PCM_IN	Input with weak pull-down
PCM_SYNC	Input with weak pull-down
PCM_CLK	Input with weak pull-down
UART_TX	Output tri-stated with weak pull-up
UART_RX	Input with weak pull-down
UART_RTS	Output tri-stated with weak pull-up
UART_CTS	Input with weak pull-down
USB_DP	Input with weak pull-down
USB_DN	Input with weak pull-down
SPI_CSB	Input with weak pull-up
SPI_CLK	Input with weak pull-down
SPI_MOSI	Input with weak pull-down
SPI_MISO	Output tri-stated with weak pull-down
AIO[3:0]	Output, driving low
RESET	Input with weak pull-down
RESETB	Input with weak pull-up
TEST_EN	Input with strong pull-down
AUX_DAC	High impedance
RX_IN	High impedance
XTAL_IN	High impedance, 250k to XTAL_OUT
XTAL_OUT	High impedance, 250k to XTAL_IN

Table 9.15: Pin States of BlueCore3-ROM on Reset

9.11.2 Status after Reset

The chip status after a reset is as follows:

- Warm Reset: Baud rate and RAM data remain available
- Cold Reset⁽¹⁾: Baud rate and RAM data not available

Note:

- ⁽¹⁾ Cold Reset constitutes one of the following:
- Power cycle
 - System reset (firmware fault code)
 - Reset signal, see Section 9.11

9.12 Power Supply

9.12.1 Voltage Regulator

An on-chip linear voltage regulator can be used to power the 1.8V dependant supplies. It is advised that a smoothing circuit using a 2.2 μ F low ESR capacitor and 2.2 Ω resistor be placed on the output VDD_ANA.

VREG_EN is provided so that the regulator can be turned off when the line is pulled low.

The regulator is switched into a low power mode when the device is sent into deep sleep mode. When the on-chip regulator is not required VDD_ANA is a 1.8V input and VREG_IN must be either open circuit or tied to VDD_ANA.

Important note

If BlueCore3-ROM Flash is being used as a development part to replicate BlueCore3-ROM functionality then VREG_EN must be pulled high externally to replicate the ROM devices functionality. If VREG_EN is not being used then connect pin VREG_EN to VREG_IN.

9.12.2 Sequencing

It is recommended that VDD_CORE, VDD_RADIO, VDD_VCO and VDD_MEM are powered at the same time. The order of powering supplies for VDD_CORE, VDD_PIO, VDD_PADS and VDD_USB is not important. However, if VDD_CORE is not present all inputs have a weak pull-down irrespective of the reset state.

9.12.3 Sensitivity to Disturbances

It is recommended that if you are supplying BlueCore3-ROM from an external voltage source that VDD_VCO, VDD_ANA and VDD_RADIO should have less than 10mV rms noise levels between 0 to 10MHz. Single tone frequencies are also to be avoided. A simple RC filter is recommended for VDD_CORE as this reduces transients put back onto the power supply rails.

The transient response of the regulator is also important as at the start of a packet, power consumption will jump to the levels defined in average current consumption section. It is essential that the power rail recovers quickly, so the regulator should have a response time of 20 μ s or less.

10 Application Schematic

10.1 6 x 6mm VFBGA 84-Ball Package

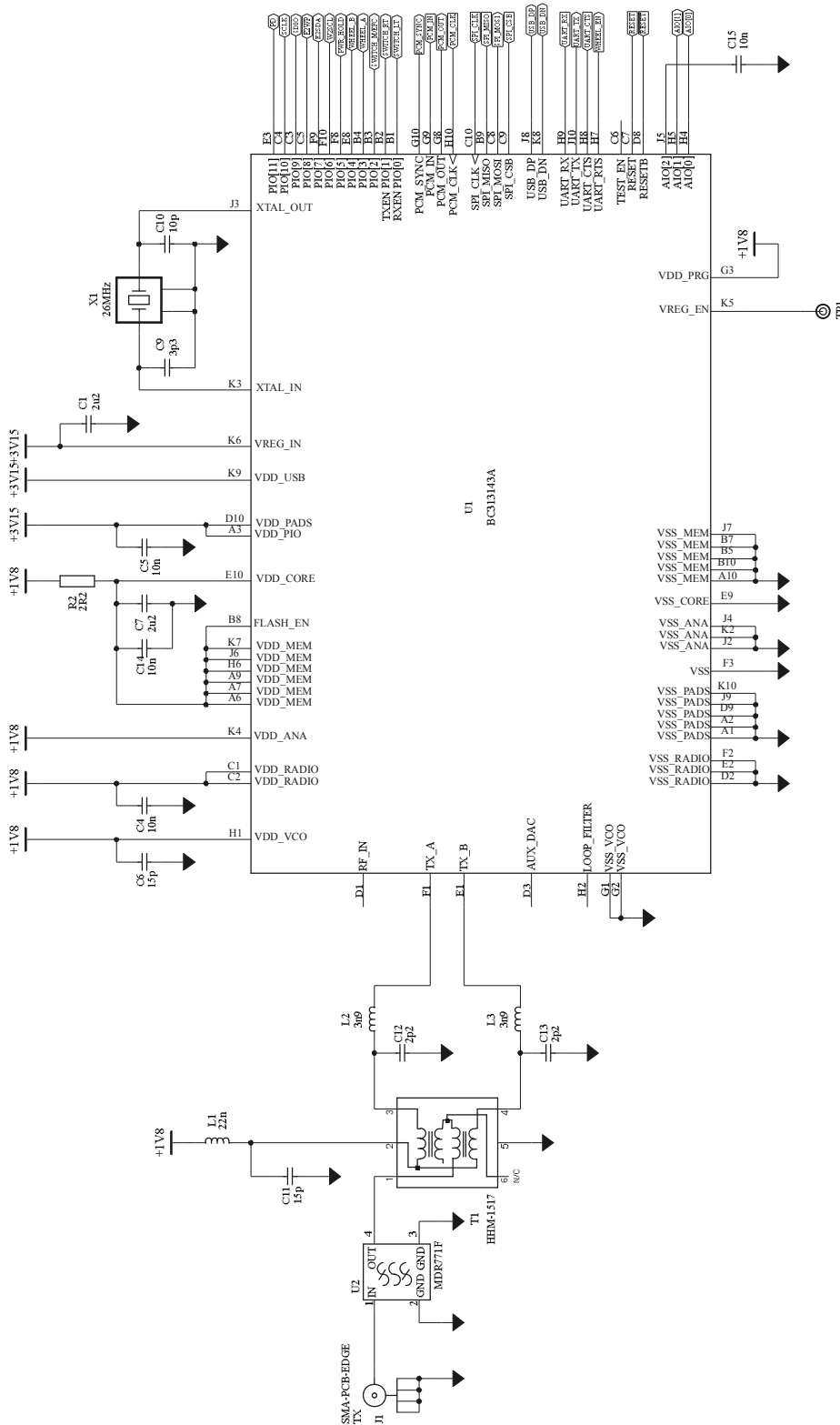

Figure 10.1: Application Circuit for Radio Characteristics Specification for 6 x 6mm VFBGA Package

11 PCB Design and Assembly Considerations

11.1 VFBGA 84-Ball Package

The following list details the recommendations to achieve maximum board-level reliability of the BlueCore3-ROM 6 x 6mm VFBGA 84-ball package:

- Non solder mask defined (NSMD) lands – lands smaller than the solder mask aperture – are preferred, because of the greater accuracy of the metal definition process compared to the solder mask process. With solder mask defined pads, the overlap of the solder mask on the land creates a step in the solder at the land interface, which can cause stress concentration and act as a point for crack initiation
- Ideally, via-in-pad technology should be employed to achieve truly NSMD lands. Where this is not possible, a maximum of one trace connected to each land is preferred and this trace should be as thin as possible – taking into consideration its current carrying and the radio frequency (RF) requirements
- 35 micron thick (1 oz.) copper lands are recommended rather than 17 micron thick (1/2 oz.), because this results in a greater standoff which has been proven to provide greater reliability during thermal cycling
- Land diameter should be 260 microns +/-10 microns to achieve optimum reliability
- Solder paste is preferred to flux during the assembly process, as this adds to the final volume of solder in the joint, increasing its reliability
- Where a nickel gold plating finish is used, the gold thickness should be kept below 0.5 microns in order to prevent brittle gold/tin intermetallics forming in the solder

12 Package Dimensions

12.1 6 x 6mm VFBGA 84-Ball Package

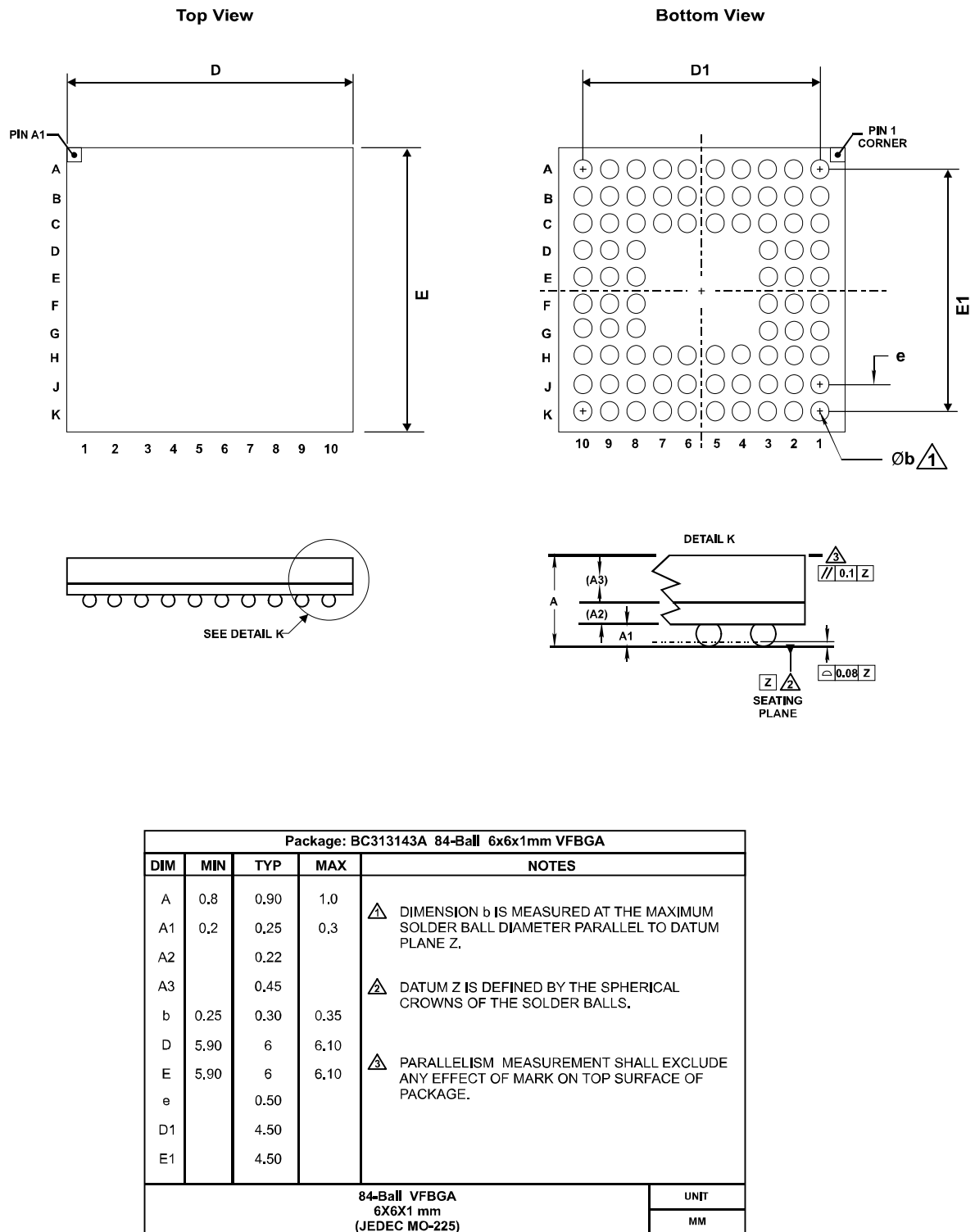
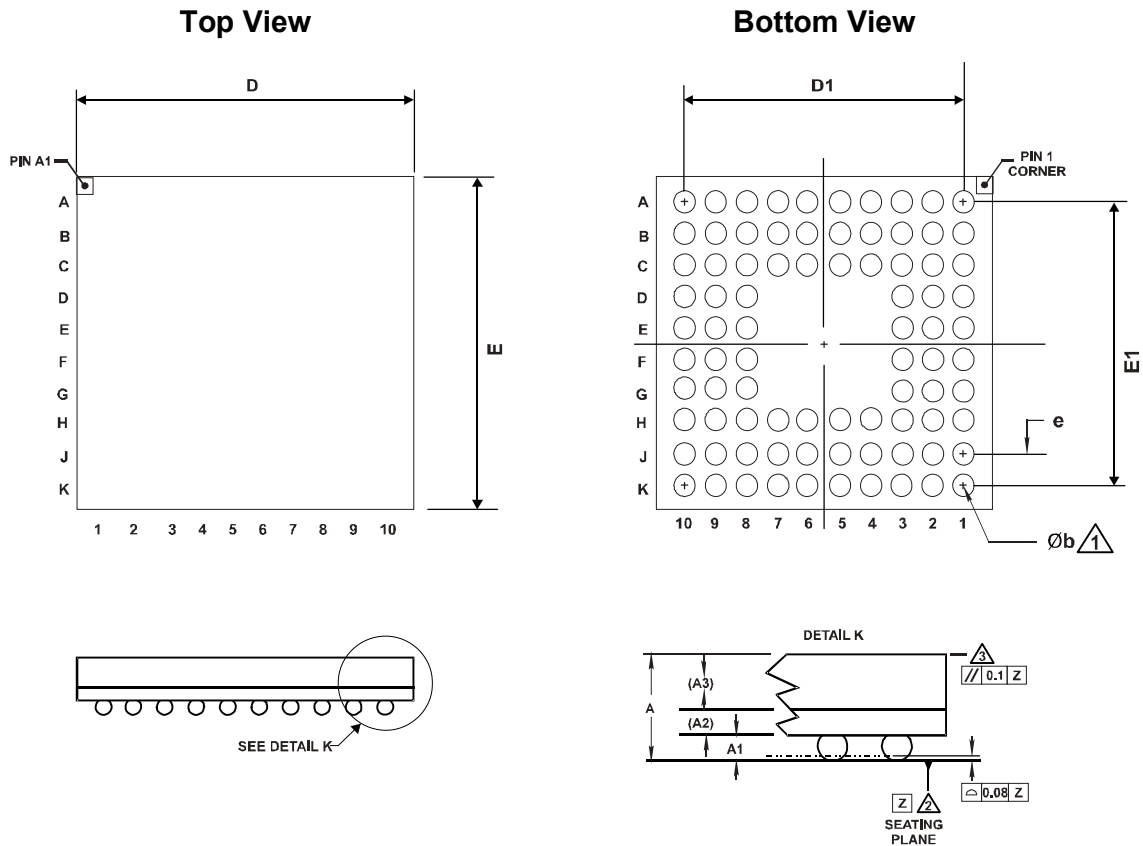

Figure 12.1: BlueCore3-ROM VFBGA Package Dimensions

12.2 6.5 x 6.5mm VFBGA 84-Ball Package



6.5 x 6.5 x 1.2mm TFBGA				
DIM	MIN	TYP	MAX	NOTES
A			1.2	
A1	0.18		0.28	⚠ DIMENSION b IS MEASURED AT THE MAXIMUM SOLDER BALL DIAMETER PARALLEL TO DATUM PLANE Z
A2		0.21		
A3		0.7		
B	0.27		0.37	⚠ DATUM Z IS DEFINED BY THE SPHERICAL CROWNS OF THE SOLDER BALLS
D		6.5		
E		6.5		⚠ PARALLELISM MEASUREMENT SHALL EXCLUDE ANY EFFECT OF MARK ON TOP SURFACE OF PACKAGE
e		0.5		
D1		4.5		
E1		4.5		
84-Ball TFBGA 6.5 x 6.5 x 1.2mm (JEDEC MO-195)				UNIT MM

Figure 12.2: BlueCore3-ROM Flash TFBGA Package Dimensions

13 Solder Profiles

The soldering profile depends on various parameters necessitating a set up for each application. The data here is given only for guidance on solder re-flow. There are four zones:

1. Preheat Zone: This zone raises the temperature at a controlled rate, typically 1-2.5°C/s.
2. Equilibrium Zone: This zone brings the board to a uniform temperature and also activates the flux. The duration in this zone (typically 2-3 minutes) will need to be adjusted to optimise the out gassing of the flux.
3. Reflow Zone: The peak temperature should be high enough to achieve good wetting but not so high as to cause component discoloration or damage. Excessive soldering time can lead to intermetallic growth which can result in a brittle joint.
4. Cooling Zone: The cooling rate should be fast, to keep the solder grains small which will give a longer lasting joint. Typical rates will be 2-5°C/s.

13.1 Example Solder Re-flow Profile for Devices with Lead-Free Solder Balls

Composition of the solder ball: Sn 95.5%, Ag 4.0%, Cu 0.5%

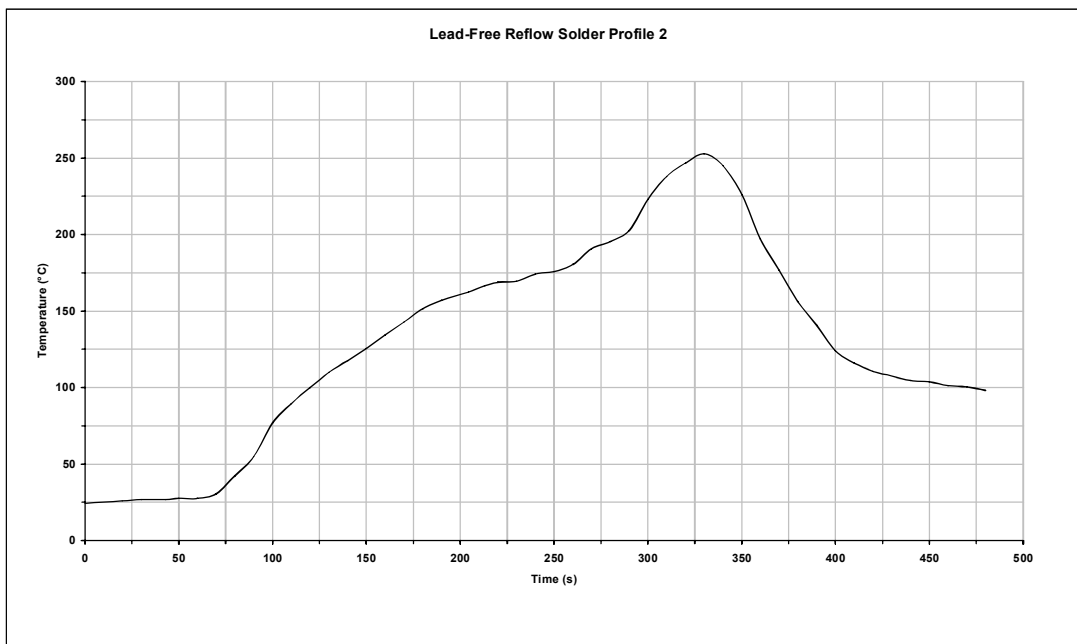

Figure 13.1: Typical Lead-Free Re-flow Solder Profile

Key features of the profile:

- Initial Ramp = 1-2.5°C/sec to 175°C±25°C equilibrium
- Equilibrium time = 60 to 180 seconds
- Ramp to Maximum temperature (250°C) = 3°C/sec max.
- Time above liquidus temperature (217°C): 45-90 seconds
- Device absolute maximum reflow temperature: 260°C

Devices will withstand the specified profile.

Lead-free devices will withstand up to 3 reflows to a maximum temperature of 260°C.

13.2 Example Solder Re-Flow Profile for Devices with Tin / Lead Solder Balls

Composition of the solder ball: Sn 62%, Pb 36.0%, Ag 2.0%

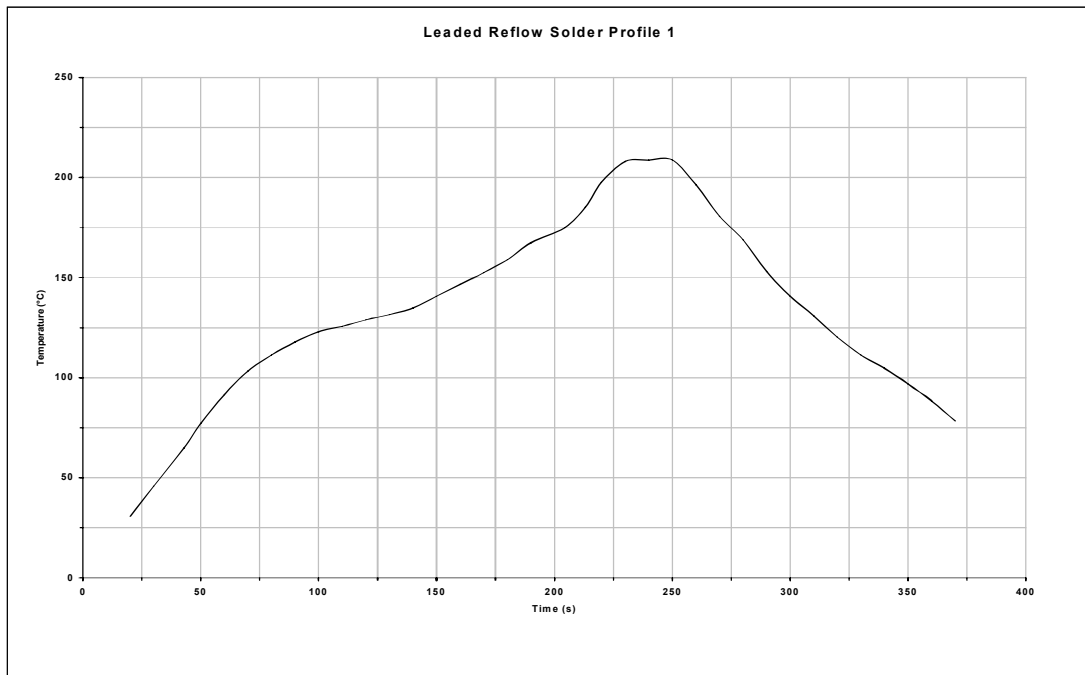

Figure 13.2: Typical Re-flow Solder Profile

Key features of the profile:

- Initial Ramp = 1-2.5°C/sec to 125°C±25°C equilibrium
- Equilibrium time = 60 to 120 seconds
- Ramp to Maximum temperature (210°C to 220°C) = 3°C/sec max.
- Time above liquidus (183°C): 45 to 90 seconds
- Device absolute maximum re-flow temperature 240°C

Devices will withstand the specified profile.

Lead-free devices will withstand up to 3 re-flows to a maximum temperature of 240°C.

14 Product Reliability Tests

Die	Test Conditions	Specification	Sample Size
ESD	Human Body Model	JEDEC	30
ESD	Machine Model	JEDEC	30
Latch-up	±200mA	JEDEC	6
Early Life	125°C	48 – 168 hours	160
Hot Life Test	125°C	1000 hours	80 (73 FITs)

Package	Test Conditions	Specification	Sample Size
Moisture Sensitivity Precon JEDEC Level 3	(125°C 24 hours) 30°C/60%RH	192 hours five re-flow simulation cycles	231
Temperature Cycling	-65°C to +150°C	500 cycles	77 from Precon
AutoClave (Steam)	121°C at 100% RH	96 hours	77 from Precon
Thermal Shock	-55°C to 125°C	100 cycles	77 from Precon
Highly Accelerated Stress Test	130°C at 85% RH	96 hours	77 from Precon ⁽¹⁾
High Temperature Storage	150°C	1000 hours	77

Note:

⁽¹⁾ Same material set as BlueCore2-ROM PnG

15 Ordering Information

15.1 BlueCore3-ROM

Interface Version	Package			Order Number
	Type	Size	Shipment Method	
UART and USB	84-Ball VFBGA	6 x 6 x 1mm	Tape and reel	BC313143AXX-IEK-E4
	84-Ball VFBGA (Pb free)	6 x 6 x 1mm	Tape and reel	BC313143AXX-IRK-E4

Note:

XX denotes firmware type and firmware version status. These are determined on a customer and project basis.

Minimum Order Quantity

2kpcs Taped and Reeled

15.2 BlueCore3-ROM Flash Software Prototyping Device

Interface Version	Package			Order Number
	Type	Size	Shipment Method	
UART and USB	84-Ball TFBGA (Pb free)	6.5 x 6.5 x 1.2mm	Tape and reel	BC31A159A-ES-ITK

Maximum Order Quantity

500pcs Taped and Reeled

16 Tape and Reel Information

Tape and reel is in accordance with EIA-481-2.

16.1 Tape Orientation and Dimensions

The general orientation of the BGA in the tape is as shown in Figure 16.1.

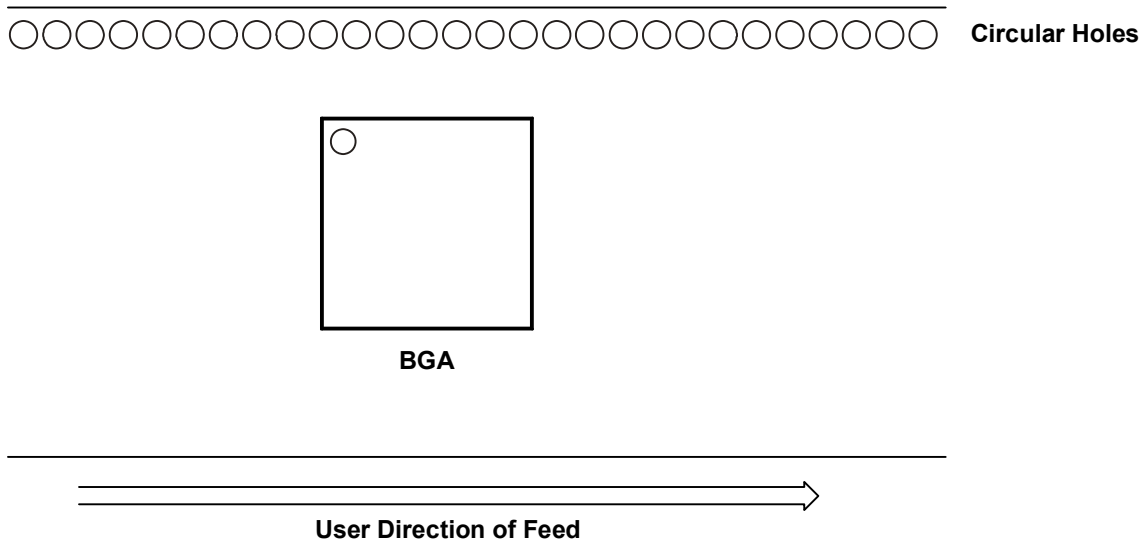

Figure 16.1: Tape and Reel Orientation

16.2 Reel Information

Reel dimensions

(All dimensions in millimeters)

Full Radius,

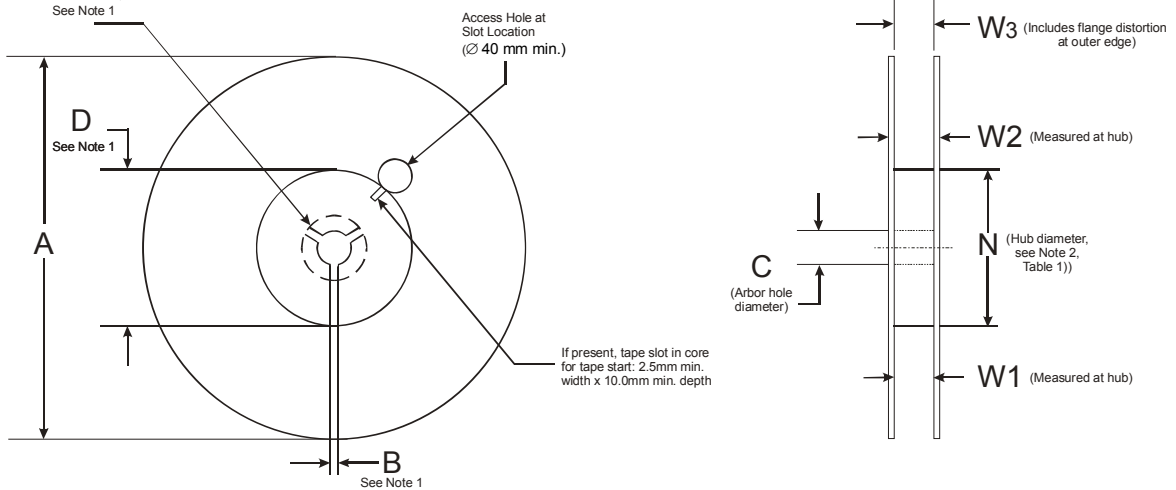

Figure 16.3: Reel Dimensions

Tape Width	B Min	C	D Min	N Min	W1
16mm	1.5mm	13.0+0.5/-0.2mm	20.2mm	50mm	16.4+2.0/-0.0mm

Table 16.1: Reel Dimensions

Tape Size	Reel Diameter, A	
	W2 Max	W3
16mm	330mm	
	22.4mm	15.9mm Min 19.4mm Max

Table 16.2: Diameter Dependent Dimensions

16.3 Dry Pack Information (6 x 6mm VFBGA 84-Ball Package Only)

The primary packed product is dry packed in accordance with Joint IPC / JEDEC J-STD-033.

All materials used in dry packing conform to EIA-541 and EIA-583.

Some illustrative views of reel dry packs are shown in Figure 16.4.





	<ul style="list-style-type: none"> Humidity Indicator Card 10% ~ 30% Desiccant: two units bags each containing 2 units of desiccant Cube of pink foam to protect tape from crushing
	<p>Desiccant and Humidity Indicator Card are put on the bottom side of the reel.</p>
	<p>Position of label on reel.</p>
	<ul style="list-style-type: none"> Caution Label is printed on dry pack bag. Dry pack bag.

Figure 16.4: Tape and Reel Packaging

Devices shipped in dry-pack bags will withstand storage in normal environmental conditions, such as 30°C and 70% RH for a minimum of one year as long as the dry-pack bag has not become punctured. Humidity indicators inside the dry-pack bag will confirm this when the bag is opened.

16.4 Baking Conditions

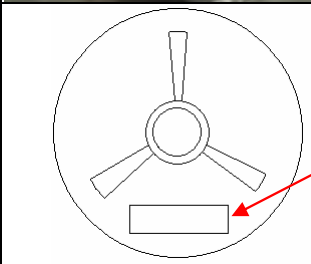
Devices may, if necessary, be re-baked at 125°C for 24 hours. If devices are still on the reel, which cannot withstand such high temperatures, they should be baked at 45°C for 192 hours at relative humidity less than 5%.

Solder wettability of parts will be unaffected by three such bakes.

16.5 Product Information

Example product information labels are shown in Figure 16.5.



Figure 16.5: Product Information Labels

A product information label is placed on each reel, primary package and shipment package.

17 Contact Information

CSR UK
Cambridge Science Park
Milton Road
Cambridge, CB4 0WH
United Kingdom
Tel: +44 (0) 1223 692 000
Fax: +44 (0) 1223 692 001
e-mail: sales@csr.com

CSR Denmark
Novi Science Park
Niels Jernes Vej 10
9220 Aalborg East
Denmark
Tel: +45 72 200 380
Fax: +45 96 354 599
e-mail: sales@csr.com

CSR U.S.
2425 N. Central Expressway
Suite 1000
Richardson
Texas 75080
USA
Tel: +1 (972) 238 2300
Fax: +1 (972) 231 1440
e-mail: sales@csr.com

CSR Korea
CSR Korea
2nd floor, Hyo-Bong Building
1364-1, SeoCho-dong
Seocho-gu
Seoul 137-863
Korea
Tel: + 82 2 3473 2372
Fax : +82 2 3473 2205
e-mail: sales@csr.com

CSR Taiwan
6th Floor, No. 407
Rui Guang Road
NeiHu, Taipei 114
Taiwan, R.O.C.
Tel: +886 2 7721 5588
Fax: +886 2 7721 5589
e-mail: sales@csr.com

CSR Japan
9F Kojimachi KS Square 5-3-3,
Kojimachi, Chiyoda-ku,
Tokyo 102-0083
Japan
Tel: +81 3 5276 2911
Fax: +81 3 5276 2915
e-mail: sales@csr.com

To contact a CSR representative, go to <http://www.csr.com/contacts.htm>

18 Document References

Document	Reference
Specification of the Bluetooth system	v1.2, 0.95, 10 October 2002
Universal Serial Bus Specification	v1.1, 23 September 1998
Selection of I ² C™ EEPROMS for use with BlueCore	bcore-an-008Pa, October 2002
Restrictions of Hazardous Substances	RoHS directive 2002/95/EC

Terms and Definitions

BlueCore	Group term for CSR's range of Bluetooth chips
Bluetooth	A set of technologies providing audio and data transfer over short-range radio connections
ACL	Asynchronous Connection-Less. A Bluetooth data packet
AC	Alternating Current
ADC	Analogue to Digital Converter
AFH	Adaptive Frequency Hopping
AGC	Automatic Gain Control
AIO	Asynchronous Input/Output
API	Application Programming Interface
BCCMD	BlueCore Command
BCSP	BlueCore™ Serial Protocol
BER	Bit Error Rate. Used to measure the quality of a link
BGA	Ball Grid Array
BIST	Built-In Self-Test
BMC	Burst Mode Controller
C/I	Carrier Over Interferer
CDMA	Code Division Multiple Access
CMOS	Complementary Metal Oxide Semiconductor
CODEC	Coder Decoder
CQDDR	Channel Quality Driven Data Rate
CSB	Chip Select (Active Low)
CSR	Cambridge Silicon Radio
CTS	Clear to Send
CVSD	Continuous Variable Slope Delta Modulation
DAC	Digital to Analogue Converter
dBm	Decibels relative to 1mW
DC	Direct Current
DDS	Direct Digital Synthesis
DFU	Device Firmware Upgrade
EEPROM	Electrically Erasable Programmable Read Only Memory
eSCO	Extended Synchronous Connection-Oriented
ESR	Equivalent Series Resistance
FSK	Frequency Shift Keying
GCI	General Circuit Interface
GSM	Global System for Mobile communications
HCI	Host Controller Interface
HV	Header Value
I/O	Input Output
IQ Modulation	In-Phase and Quadrature Modulation
IF	Intermediate Frequency
ISDN	Integrated Services Digital Network
ISM	Industrial, Scientific and Medical
ksamples/s	kilosamples per second

L2CAP	Logical Link Control and Adaptation Protocol (protocol layer)
LC	Link Controller
LCD	Liquid Crystal Display
LED	Light Emitting Diode
LM	Link Manager
LNA	Low Noise Amplifier
LSB	Least-Significant Bit
μ-law	Audio Encoding Standard
MMU	Memory Management Unit
MISO	Master In Serial Out
NRE	Non Recurring Engineering
NSMD	Non Solder Mask Defined
OHCI	Open Host Controller Interface
PA	Power Amplifier
PCB	Printed Circuit Board
PCM	Pulse Code Modulation. Refers to digital voice data
PDA	Personal Digital Assistant
PICS	Protocol Implementation Conformance Statement
PIO	Parallel Input Output
PLL	Phase Lock Loop
ppm	parts per million
PS Key	Persistent Store Key
RAM	Random Access Memory
RF	Radio Frequency
RFCOMM	Protocol layer providing serial port emulation over L2CAP
RISC	Reduced Instruction Set Computer
rms	root mean squared
ROM	Read Only Memory
RoHS	Restrictions of Hazardous Substances
RSSI	Receive Signal Strength Indication
RTS	Ready To Send
RX	Receive or Receiver
SCO	Synchronous Connection-Oriented. Voice oriented Bluetooth packet
SDK	Software Development Kit
SDP	Service Discovery Protocol
SIG	Special Interest Group
SPI	Serial Peripheral Interface
SSI	Signal Strength Indication
TBA	To Be Announced
TCXO	Temperature Controlled crystal Oscillator
TFBGA	Thin Fine-Pitch Ball Grid Array
TX	Transmit or Transmitter
UART	Universal Asynchronous Receiver Transmitter
UHCI	Upper Host Control Interface
USB	Universal Serial Bus or Upper Side Band (depending on context)

VCO	Voltage Controlled Oscillator
VFBGA	Very Fine Ball Grid Array
VM	Virtual Machine
W-CDMA	Wideband Code Division Multiple Access

Document History

Date:	Revision:	Reason for Change:
11 FEB 03	a	Original publication of Advance Information Product Data Sheet (CSR reference BC313143A-ds-001Pa)
JUL 03	b	Pinout information for 6 x 6 VFBGA corrected.
SEP 03	c	Radio Characterisation section updated to include design target figures for -20°C to 105°C temperature ranges.
OCT 03	d	CSP Pinout information and RoHS statement added.
18 DEC 03	e	Pinout information for 6 x 6 VFBGA modified Device terminal descriptions layout brought inline with rest of BlueCore3 family
05 APR 04	f	S-parameter data, RF characteristics and BlueCore3-ROM Flash added. Status moved to Production
05 MAY 04	g	Production information added.
07 MAY 04	h	Ordering codes amended.
02 JUN 04	i	Power consumption figure corrected for Master ACL with file transfer @115200
30 JUL 04	j	BC31A159A-ES-ITK ordering code amended.
03 FEB 05	k	Device diagrams and application schematic amended.
09 FEB 05	l	Application schematic and pin-out information amended.
27 JUN 05	m	Linear Regulator maximum load current figure corrected in Electrical Characteristics. Input range for On-chip Linear Regulator amended in Key Features Amended footnote to Linear Regulator table concerning VREG_IN and VREG_EN in Electrical Characteristics. Title of Record of Changes changed to Document History; Acronyms and Definitions to Terms and Definitions Updated copyright information in Status Information
07 JUL 05	n	Updated Contact Information

BlueCore™3-ROM

Product Data Sheet

BC313143A-ds-001Pn

July 2005