



Am29827A

High-Performance Buffer

DISTINCTIVE CHARACTERISTICS

- High speed buffers and inverters
 - $t_{PD} = 5.0$ ns typ
 - Inverting $t_{PD} = 4.5$ ns typ
- 200 mV minimum Input hysteresis on Input data ports
- Three-state outputs glitch-free during power-up and power-down
- I_{OL} : 48 mA Commercial
- Higher speed, lower power version of the Am29827

GENERAL DESCRIPTION

The Am29827A Bus Buffer provides high performance bus interface buffering for wide address/data paths or buses carrying parity. The device features a 10-bit wide data path and NORed output enables for maximum control flexibility. The Am29827A has non-inverting outputs, and features data inputs with 200 mV minimum input hysteresis to provide improved noise immunity. The

Am29827A is produced with AMD's proprietary IMOX™ bipolar process, and features typical propagation delays of 5 ns.

Each member of the Am29800A Bus Interface Family is designed to drive high-capacitive loads while providing low-capacitive bus loading at both inputs and outputs.

BLOCK DIAGRAM

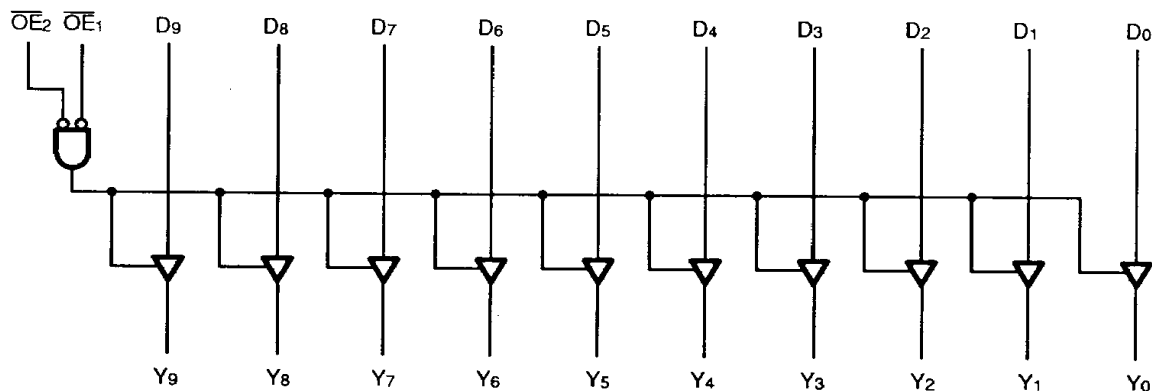

07139-001A

**CONNECTION DIAGRAM
(Top View)**

DIP

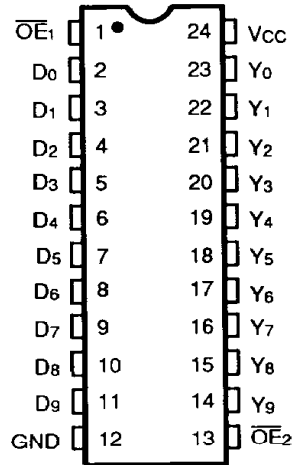

07139-002A

LOGIC SYMBOL

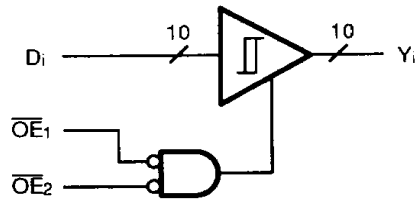

07139-003A

FUNCTION TABLE

Inputs			Outputs	Function
\overline{OE}_1	\overline{OE}_2	D_i	Y_i	
L	L	H	H	Transparent
L	L	L	L	Transparent
X	H	X	Z	Hi-Z
H	X	X	Z	Hi-Z

H = HIGH
 L = LOW
 X = Don't Care
 Z = High Impedance

ORDERING INFORMATION

Standard Products

AMD standard products are available in several packages and operating ranges. The order number (Valid Combination) is formed by a combination of:

- a. Device Number
- b. Speed Option (if applicable)
- c. Package Type
- d. Temperature Range
- e. Optional Processing

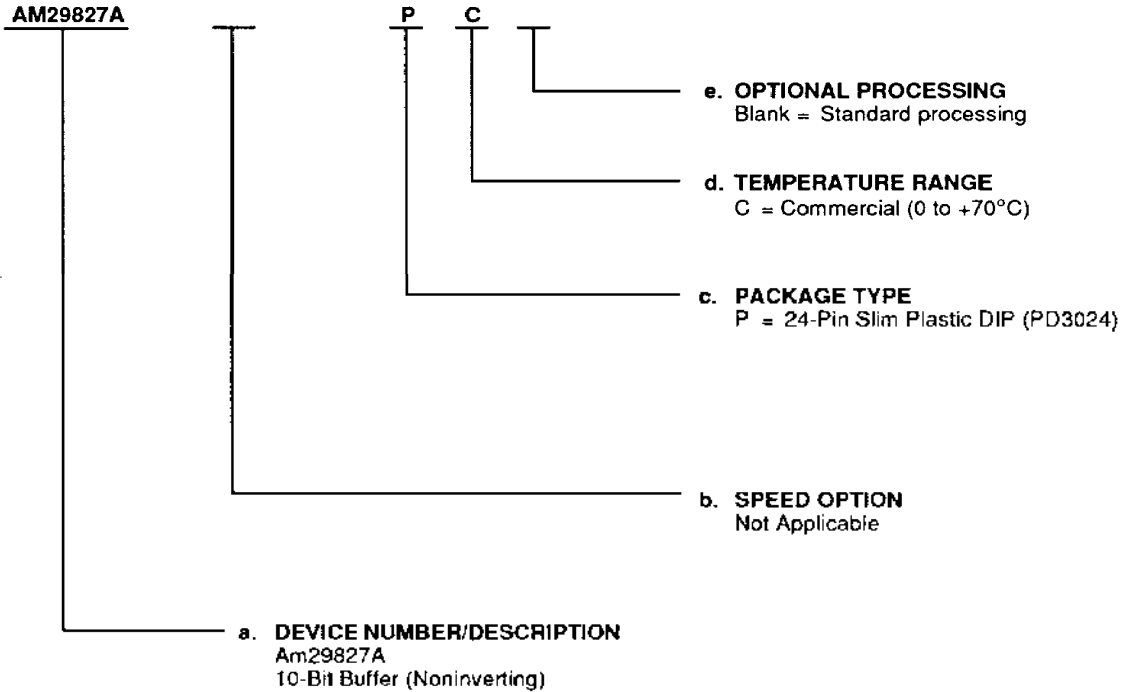

Valid Combinations	
AM29827A	PC

Valid Combinations

Valid Combinations list configurations planned to be supported in volume for this device. Consult the local AMD sales office to confirm availability of specific valid combinations or to check on newly released combinations, and to obtain additional data on AMD's standard military grade products.

PIN DESCRIPTION

\overline{OE}_i

Output Enables (Input, Active LOW)

When both Output Enables are LOW, the outputs are enabled. When either one or both are HIGH, the outputs are Hi-Z.

D_i

Data Inputs (Input)

D_i are the 10-bit data inputs.

Y_i

Data Outputs (Output)

Y_i are the 10-bit data outputs.



ABSOLUTE MAXIMUM RATINGS

Storage Temperature	-65 to +150°C
Ambient Temperature with Power Applied	-55 to +125°C
Supply Voltage to Ground Potential Continuous	-0.5 V to +7.0 V
DC Voltage Applied to Outputs for High Output State	-0.5 V to +5.5 V
DC Input Voltage	-1.5 V to +6.0 V
Output Current, into Outputs	100 mA
DC Input Current	-30 mA to +5.0 mA

Stresses above those listed under Absolute Maximum Ratings may cause permanent device failure. Functionality at or above these limits is not implied. Exposure to absolute maximum ratings for extended periods may affect device reliability.

OPERATING RANGES

Commercial (C) Devices

Temperature (T _A)	0 to +70°C
Supply Voltage (V _{CC})	+4.5 V to +5.5 V

Operating ranges define those limits between which the functionality of the device is guaranteed.

DC CHARACTERISTICS over operating ranges unless otherwise specified

Parameter Symbol	Parameter Description	Test Conditions	Min.	Max.	Unit
V _{OH}	Output HIGH Voltage	V _{CC} = 4.5 V, I _{OH} = -15 mA	2.4		V
		V _{IN} = V _{IH} or V _{IL} , I _{OH} = -24 mA	2.0		
V _{OL}	Output LOW Voltage	V _{CC} = 4.5 V, I _{OL} = 48 mA V _{IN} = V _{IH} or V _{IL}		0.5	V
V _{IH}	Input HIGH Voltage	Guaranteed Input Logical HIGH Voltage for All Inputs (Note 1)	2.0		V
V _{IL}	Input LOW Voltage	Guaranteed Input Logical LOW Voltage for All Inputs (Note 1)		0.8	V
V _I	Input Clamp Voltage	V _{CC} = 4.5 V, I _{IN} = -18 mA		-1.2	V
V _{HYST}	Input Hysteresis		200		mV
I _{IL}	Input LOW Current	V _{CC} = 5.5 V, V _{IN} = 0.4 V		-0.5	mA
I _{IH}	Input HIGH Current	V _{CC} = 5.5 V, V _{IN} = 2.7 V		50	μA
I _I	Input HIGH Current	V _{CC} = 5.5 V, V _{IN} = 5.5 V		100	μA
I _{OZH}	Output Off-State Current (High Impedance)	V _{CC} = 5.5 V, V _O = 2.7 V		50	μA
		V _{CC} = 5.5 V, V _O = 0.4 V		-50	
I _{SC}	Output Short-Circuit Current	V _{CC} = 5.5 V, V _O = 0 V (Note 2)	-75	-250	mA
I _{OFF}	Bus Leakage Current	V _{CC} = 0 V, V _{OUT} = 2.9 V		100	μA
I _{CC}	Supply Current	V _{CC} = 5.5 V			mA
		Outputs LOW		80	
		Outputs HIGH		55	
	Unloaded	Outputs Hi-Z		70	

Notes:

- Input thresholds are tested during DC parameter testing, and may be tested in combination with other DC parameters.
- Not more than one output shorted at a time. Duration of the short-circuit test should not exceed one second.

SWITCHING CHARACTERISTICS over operating ranges unless otherwise specified

Parameter Symbol	Parameter Description	Test Conditions*	Min.	Max.	Unit
t _{PLH}	Data (Di) to Output (Yi)	C _L = 50 pF R ₁ = 500 Ω R ₂ = 500 Ω		8	ns
t _{PHL}				8	ns
t _{zH}	Output Enable Time \overline{OE} to Y _i			11	ns
t _{zL}				12	ns
t _{Hz}	Output Disable Time \overline{OE} to Y _i			10	ns
t _{Lz}				10	ns

*See test circuit and waveforms (Chapter 2).