



Am26LS32/Am26LS33

Quad Differential Line Receivers

DISTINCTIVE CHARACTERISTICS

- Input voltage range of 15 V (differential or common mode) on Am26LS33; 7 V (differential or common mode) on Am26LS32
 - 200 mV sensitivity over the input voltage range on Am26LS32;
 - 500 mV sensitivity on Am26LS33
- 6k minimum input impedance with 30 mV input hysteresis
- The Am26LS32 meets all the requirements of RS-422 and RS-423
- Operation from single +5 V supply
- Fail safe input-output relationship. Output always high when inputs are open
- Three-state drive, with choice of complementary output enables, for receiving directly onto a data bus

GENERAL DESCRIPTION

The Am26LS32 is a quad line receiver designed to meet the requirements of RS-422 and RS-423, and Federal Standards 1020 and 1030 for balanced and unbalanced digital data transmission.

The Am26LS32 features an input sensitivity of 200 mV over the input voltage range of ± 7 V.

The Am26LS33 features an input sensitivity of 500 mV over the input voltage range of ± 15 V.

The Am26LS32 and Am26LS33 provide an enable and disable function common to all four receivers. Both parts feature 3-state outputs with 8 mA sink capability and incorporate a fail safe input-output relationship which keeps the outputs high when the inputs are open.

The Am26LS32 and Am26LS33 are constructed using Advanced Low-Power Schottky processing.

BLOCK DIAGRAM

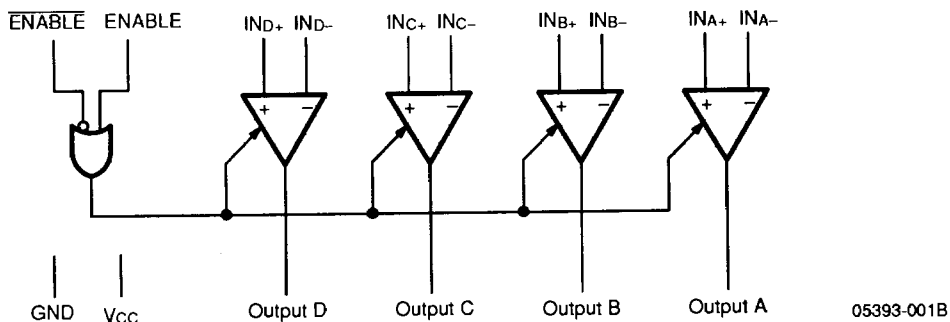

RELATED AMD PRODUCTS

Part No.	Description
26LS29	Quad Three-State Single Ended RS-423 Line Driver
26LS30	Dual Differential RS-422 Party Line/Quad Single Ended RS-423 Line Driver
26LS31	Quad High Speed Differential Line Driver

CONNECTION DIAGRAMS

Top View

DIP

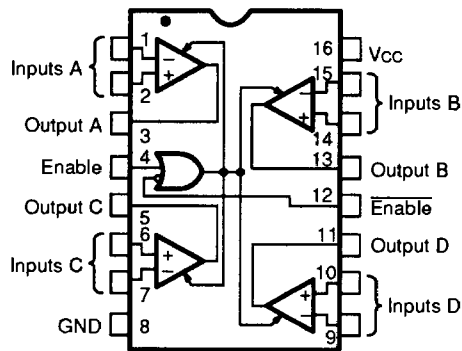

05393-002B

LCC

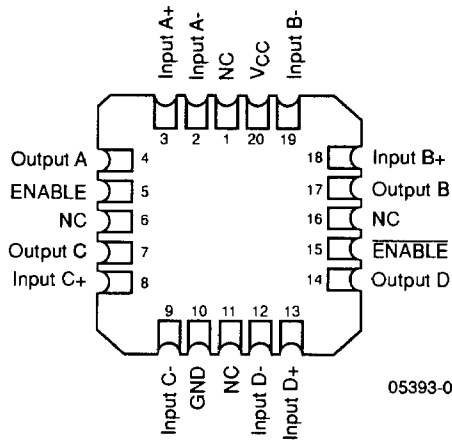

05393-003B

Note:

Pin 1 is marked for orientation.

ORDERING INFORMATION

Standard Products

AMD standard products are available in several packages and operating ranges. The order number (Valid Combination) is formed by a combination of:

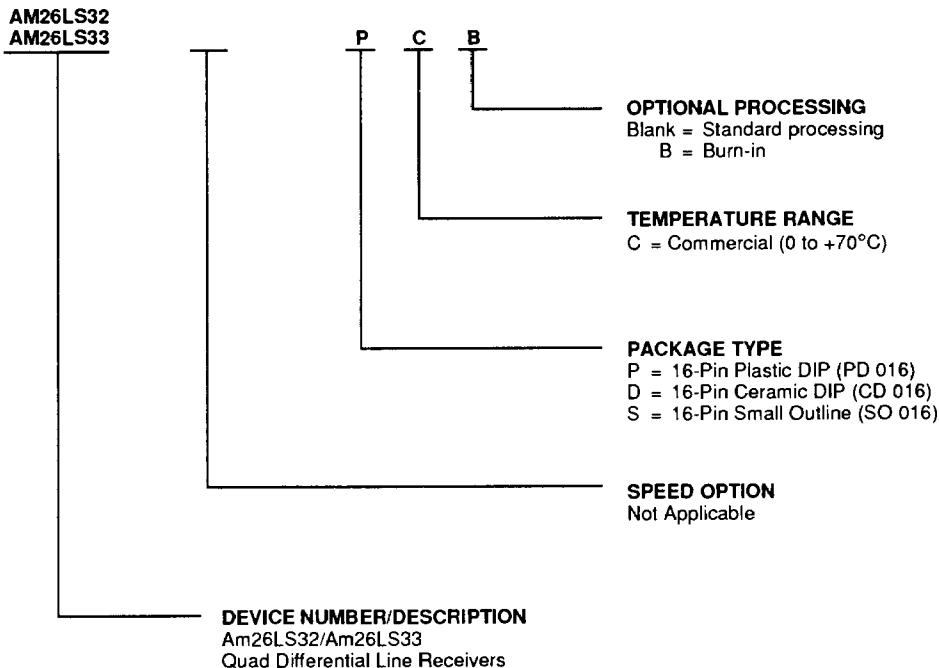

Valid Combinations	
AM26LS32	PC, PCB, DC,
AM26LS33	DCB, SC

Valid Combinations

Valid Combinations list configurations planned to be supported in volume for this device. Consult the local AMD sales office to confirm availability of specific valid combinations or to check on newly released combinations, and to obtain additional data on AMD's standard military grade products.

MILITARY ORDERING INFORMATION
Standard Military Drawing (SMD)/DESC Products

AMD products for Aerospace and Defense applications are available in several packages and operating ranges. Standard Military Drawing (SMD)/DESC products are fully compliant with MIL-STD-883C requirements. The order number (Valid Combination) for SMD/DESC products is formed by a combination of:

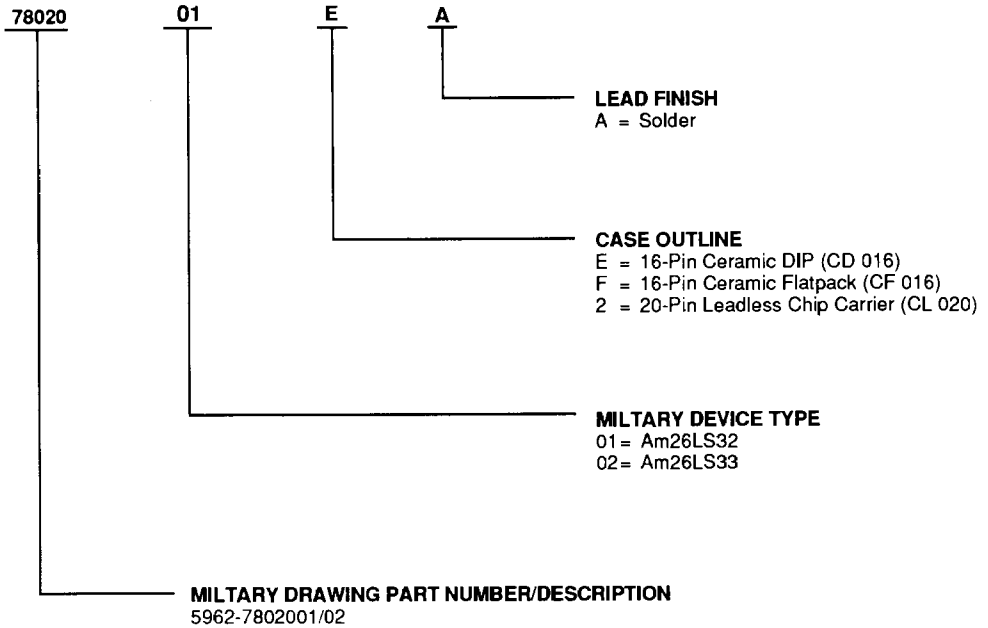

Valid Combinations	
5962-7802001	MEA, MFA, M2A
5962-7802002	

Valid Combinations

Valid Combinations list configurations planned to be supported in volume for this device. Consult the local AMD sales office to confirm availability of specific valid combinations, or to check on newly released combinations.

Group A Tests

Group A tests consist of Subgroups 1, 2, 3, 7, 8, 9, 10, 11.

MILITARY ORDERING INFORMATION

APL Products

AMD products for Aerospace and Defense applications are available in several packages and operating ranges. APL (Approved Products List) products are fully compliant with MIL-STD-883C requirements. The order number (Valid Combination) is formed by a combination of:

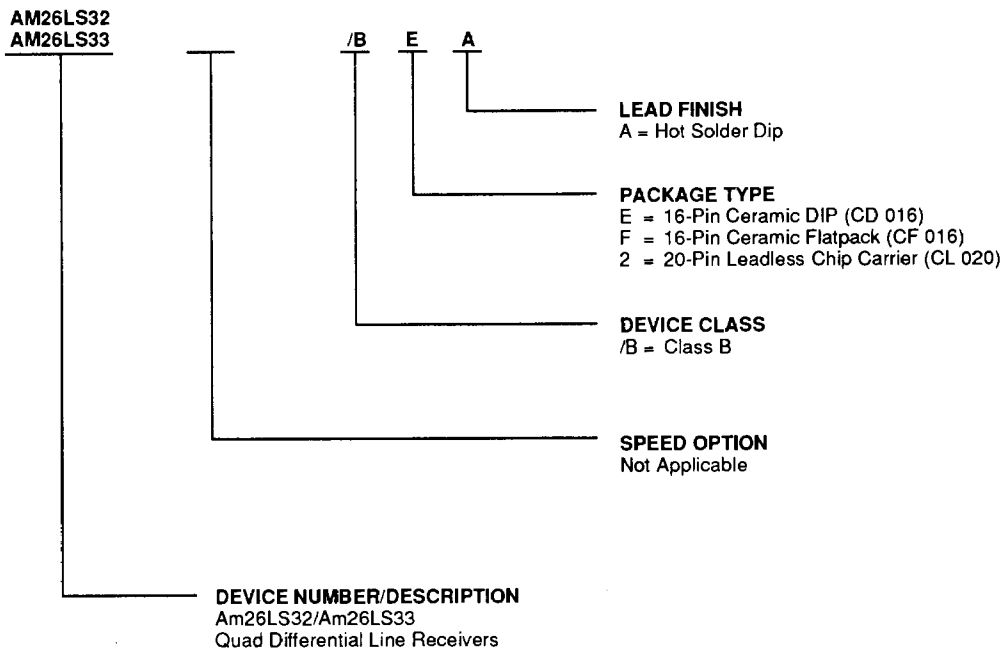

Valid Combinations	
AM26LS32	/BEA, /BFA, /B2A
AM26LS33	

Valid Combinations

Valid Combinations list configurations planned to be supported in volume for this device. Consult the local AMD sales office to confirm availability of specific valid combinations, or to check on newly released combinations.

Group A Tests

Group A tests consist of Subgroups 1, 2, 3, 7, 8, 9, 10, 11.

ABSOLUTE MAXIMUM RATINGS

Supply Voltage	7.0 V
Common Mode Range	±25 V
Differential Input Voltage	±25 V
Enable Voltage	7.0 V
Output Sink Current	50 mA
Storage Temperature Range	-65 to +165°C

OPERATING RANGES

Commercial (C) Devices

Temperature	0 to +70°C
Supply Voltage	+4.75 V to +5.25 V

Military (M) Devices

Temperature	-55 to +125°C
Supply Voltage	+4.5 V to +5.5 V

Stresses above those listed under Absolute Maximum Ratings may cause permanent device failure. Functionality at or above these limits is not implied. Exposure to absolute maximum ratings for extended periods may affect device reliability.

Operating ranges define those limits between which the functionality of the device is guaranteed.

DC CHARACTERISTICS over operating ranges unless otherwise specified

Parameter Symbol	Parameter Description	Test Conditions	Min.	Typ. (Note 1)	Max.	Unit	
V _{TH}	Differential Input Voltage	V _{OUT} = V _{OL} or V _{OH} (Note 5)	Am26LS32, -7 V ≤ V _{CM} ≤ +7 V	-0.2	±0.06	+0.2	V
		Am26LS33, -15 V ≤ V _{CM} ≤ +15 V	-0.5	±0.12	+0.5		
R _{IN}	Input Resistance	-15 V ≤ V _{CM} ≤ +15 V (One input AC ground) (Note 4)	6.0	9.8		kΩ	
I _{IN}	Input Current (Under Test)	V _{IN} = +15 V, Other Input -15 V ≤ V _{IN} ≤ +15 V			2.3	mA	
I _{IN}	Input Current (Under Test)	V _{IN} = -15 V, Other Input -15 V ≤ V _{IN} ≤ +15 V			-2.8	mA	
V _{OH}	Output HIGH Voltage	V _{CC} = Min., ΔV _{IN} = +1.0 V	COM'L	2.7	3.4		V
		V _{ENABLE} = 0.8 V, I _{OH} = -440 μA	MIL	2.5	3.4		
V _{OL}	Output LOW Voltage	V _{CC} = Min., ΔV _{IN} = -1.0 V	I _{OL} = 4.0 mA			0.4	V
		V _{ENABLE} = 0.8 V	I _{OL} = 8.0 mA			0.45	
V _{IL}	Enable LOW Voltage	(Note 2)			0.8	V	
V _{IH}	Enable HIGH Voltage	(Note 2)	2.0			V	
V _{IC}	Enable Clamp Voltage	V _{CC} = Min., I _{IN} = -18 mA			-1.5	V	
I _O	Off-state (High Impedance) Output Current	V _{CC} = Max.	V _O = 2.4 V			20	μA
			V _O = 0.4 V			-20	
I _{IL}	Enable LOW Current	V _{IN} = 0.4 V, V _{CC} = Max.		-0.2	-0.36	mA	
I _{IH}	Enable HIGH Current	V _{IN} = 2.7 V, V _{CC} = Max.			20	μA	
I _I	Enable Input High Current	V _{IN} = 5.5 V, V _{CC} = Max.			100	μA	
I _{SC}	Output Short Circuit Current	V _O = 0 V, V _{CC} = Max., ΔV _{IN} = +1.0 V (Note 3)	-15	-50	-85	mA	
I _{CC}	Power Supply Current	V _{CC} = Max., All V _{IN} = GND, Outputs Disabled		52	70	mA	
V _{HYST}	Input Hysteresis	T _A = 25°C, V _{CC} = 5.0 V, V _{CM} = 0 V		30		mV	

Notes:

- All typical values are V_{CC} = 5.0 V, T_A = 25°C.
- Input thresholds are tested during DC tests and may be done in combination with testing of other DC parameters.
- Not more than one output should be shorted at a time. Duration of short circuit test should not exceed one second.
- R_{IN} is not directly tested but is correlated. (See Attachment I)
- Input voltage is not tested directly due to tester accuracy limitation but is threshold correlated. (See Attachment II)





SWITCHING CHARACTERISTICS

Parameter Symbol	Parameter Description	Test Conditions	Min.	Typ. (Note 1)	Max.	Unit
AC Parameters (T_A = +25°C)						
t _{PLH}	Propagation Delay From Input to Output	C _L 15 pF, R _{L1} = 5 kΩ, R _{L2} = 2 kΩ, V _{CC} = 5.0		17	25	ns
t _{PHL}	Propagation Delay From Input to Output	C _L 15 pF, R _{L1} = 5 kΩ, R _{L2} = 2 kΩ, V _{CC} = 5.0		17	25	ns
t _{LZ}	Enable to Output	V _{CC} = 5.0, C _L 5 pF, R _{L1} = 5 kΩ, R _{L2} = 2 kΩ		20	30	ns
t _{HZ}	Enable to Output	V _{CC} = 5.0, C _L 5 pF, R _{L1} = 5 kΩ, R _{L2} = 2 kΩ		15	22	ns
t _{ZL}	Enable to Output	V _{CC} = 5.0, C _L 15 pF, R _{L1} = 5 kΩ, R _{L2} = 2 kΩ		15	22	ns
t _{ZH}	Enable to Output	V _{CC} = 5.0, C _L 15 pF, R _{L1} = 5 kΩ, R _{L2} = 2 kΩ		15	22	ns
AC Parameters (-55°C to +125°C)						
t _{PLH}	Propagation Delay From Input to Output	C _L 15 pF, R _{L1} = 5 kΩ, R _{L2} = 2 kΩ		23	38	ns
t _{PHL}	Propagation Delay From Input to Output	C _L 15 pF, R _{L1} = 5 kΩ, R _{L2} = 2 kΩ		22	38	ns
t _{PDZH}	Propagation Delay From Enable to Output	C _L 15 pF, R _{L1} = 5 kΩ, R _{L2} = 2 kΩ		17	33	ns
t _{PZL}	Propagation Delay From Enable to Output	C _L 15 pF, R _{L1} = 5 kΩ, R _{L2} = 2 kΩ		25	33	ns
t _{PDHZ}	Propagation Delay From Enable to Output	C _L 5 pF, R _{L1} = 5 kΩ, R _{L2} = 2 kΩ		18	33	ns
t _{PZLZ}	Propagation Delay From Enable to Output	C _L 5 pF, R _{L1} = 5 kΩ, R _{L2} = 2 kΩ		24	45	ns
Tristate Delays for $\overline{\text{Enable}}$ (T_A = +25°C)						
t _{PDZH}	Propagation Delay From Enable to Output	C _L 15 pF, R _{L1} = 5 kΩ, R _{L2} = 2 kΩ		16	32	ns
t _{PZL}	Propagation Delay From Enable to Output	C _L 15 pF, R _{L1} = 5 kΩ, R _{L2} = 2 kΩ		23	33	ns
t _{PDHZ}	Propagation Delay From Enable to Output	C _L 5 pF, R _{L1} = 5 kΩ, R _{L2} = 2 kΩ		14	24	ns
t _{PZLZ}	Propagation Delay From Enable to Output	C _L 5 pF, R _{L1} = 5 kΩ, R _{L2} = 2 kΩ		14	32	ns
Tristate Delays for $\overline{\text{Enable}}$ (-55°C to +125°C)						
t _{PDZH}	Propagation Delay From Enable to Output	C _L 15 pF, R _{L1} = 5 kΩ, R _{L2} = 2 kΩ		23	48	ns
t _{PZL}	Propagation Delay From Enable to Output	C _L 15 pF, R _{L1} = 5 kΩ, R _{L2} = 2 kΩ		35	50	ns
t _{PDHZ}	Propagation Delay From Enable to Output	C _L 5 pF, R _{L1} = 5 kΩ, R _{L2} = 2 kΩ		20	36	ns
t _{PZLZ}	Propagation Delay From Enable to Output	C _L 5 pF, R _{L1} = 5 kΩ, R _{L2} = 2 kΩ		22	48	ns

Note:

1. All typical values are V_{CC} = 5.0 V, T_A = 25°C.

KEY TO SWITCHING WAVEFORMS

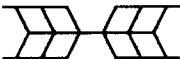
WAVEFORM	INPUTS	OUTPUTS
	Must Be Steady	Will Be Steady
	May Change from H to L	Will Be Changing from H to L
	May Change from L to H	Will Be Changing from L to H
	Don't Care, Any Change Permitted	Changing, State Unknown
	Does Not Apply	Center Line is High Impedance "Off" State

KS000010

SWITCHING WAVEFORMS

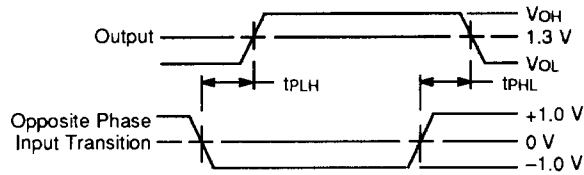

Propagation Delay (Notes 1 and 3)

05393-004B

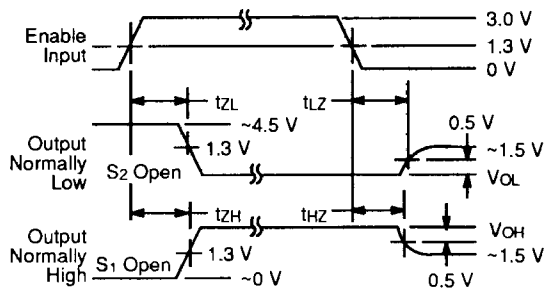

Enable and Disable Times (Notes 2 and 3)

Notes:

05393-005B

1. Diagram shown for ENABLE LOW.
2. S₁ and S₂ of Load Circuit are closed except where shown.
3. Pulse Generator for All Pulses: Rate ≤ 1.0 MHz; Z₀ = 50 Ω; t_r ≤ 15 ns; t_f ≤ 6.0 ns.

SWITCHING TEST CIRCUIT FOR THREE-STATE OUTPUTS

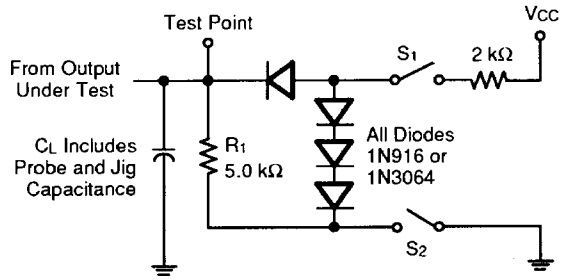

05393-006B

Am26LS32/32B/33/34 Input Resistance and Input Current (Attachment I)

Input resistance measurement for differential inputs on line receivers are generally not measured directly. Instead they are correlated to an input current measurement and to the process resistor temperature coefficient. The assumptions made include 1) Process resistor temperature coefficient is known and 2) The open input bias voltage for the input is known or measured within the same test sequence.

Under the above assumptions R_{IN} can be correlated to the input current measured. The expression

$$R_{IN} = \frac{(V_{ICM} - V_{IN}) (R_T)}{(I_{IN}) (R_{25})}$$

where V_{ICM} is the open input bias voltage of the Line Receiver. When applying this correlation to the 26LS32 die, the following criteria have been set.

- 1) V_{ICM} and I_{IN} are the values screened at wafer sort.
- 2) Temperature coefficients are for 800 ohm/square which gives 0.96 at 0°C and 0.93 at -55°C.

When setting limits, characterized values for V_{ICM} have been used instead of the test programmed limit value. $R_{IN} (dif)$ is $R_{IN} (dif) = 2 R_{IN}$.

For the Am26LS32/32B/33/34

$$R_{IN} \text{ Min.} = \frac{(2.56 - -15) 0.96}{I_{IN} (\text{Max.})} = 16.8/I_{IN} (\text{Max.}) \text{ Comm.},$$

and

$$R_{IN} \text{ Min.} = 16.3/I_{IN} (\text{Max.}) \text{ Mil.}$$

Worst Case Measurement for Input Current

Two considerations have been used to determine the test condition for input current of the data path for the Am26LS32 Line Receiver.

- 1) Input current is tested on the 26LS32 with the pin under test at one end of the range (+15 V for example) and the untested pin at the opposite extreme of the input range under test. If both pins were at the same test voltage the internal bias generator would have a lower output voltage for tests at -15 V V_{IN} and a higher output voltage at +15 V V_{IN} . This would produce test currents less than maximum.
- 2) For the 26LS32, breakdown of the differential inputs is the primary failure to the data sheet specification. Hence, both breakdown voltage and input current are tested during the input current tests.

Test Documentation For Am26LS32/32B/34 V_{TH} (Attachment II)

Input threshold (V_{TH}) for the Am26LS32/32B/34 is described by the equation,

$$V_{TH} = (N+1) (1+R1/R) K^*T/Q ((1+Rh/(m (Rc+Rh))) / (1-Rh/ (M(Rc+Rh))))$$

Where $N+1$ is the attenuator ratio, $R1/R$ is the attenuator ratio mismatch, M is the ratio of the input stage current to hysteresis stage current, and R_h and R_c are input stage loads. For Am26LS32 – 34 devices which pass function tests, V_{OH} and V_{OL} tests, thresholds for all inputs within the operating range of the circuit.

The Test system is unable to force input thresholds within the accuracy required for the Am26LS32 – 34 specifications. Figure 1 plots the expected values for V_{TH} , the worst case values at 25°C and 155°C. Also shown are the test values for V_{TH} at the -1.5 V input (V_{IN}). In addition, the test voltage at -7 V V_{IN} is shown. For the figure it is seen that the worst case value for the test limit shown would be +/-165 mV, where +/- 102 mV

is expected for process parameters and the equation for V_{TH} . Further the 25 mV negative guardband used for -7 V testing is less than half the machine uncertainty of 60 mV.

When QA testing for Am26LS32/32B/34 is done, thresholds are screened for V_{CM} other than -1.5 V. These additional tests are considered functional tests only, and the precision threshold tests which insure compliance with data sheet limits are those tests performed where the inputs are tested near -1.5 V.

The actual threshold tests are done as a sequence where a setup is performed which preconditions the DUT to a logic one state, then the threshold correlation for a logic zero is tested followed by a threshold correlation for logic one to complete the sequence. The limit values for the setup (V_t SET), logic zero test (V_t "-"), and logic one test (V_t "+") are listed under V_{TH} for supply value of 5.0 V.

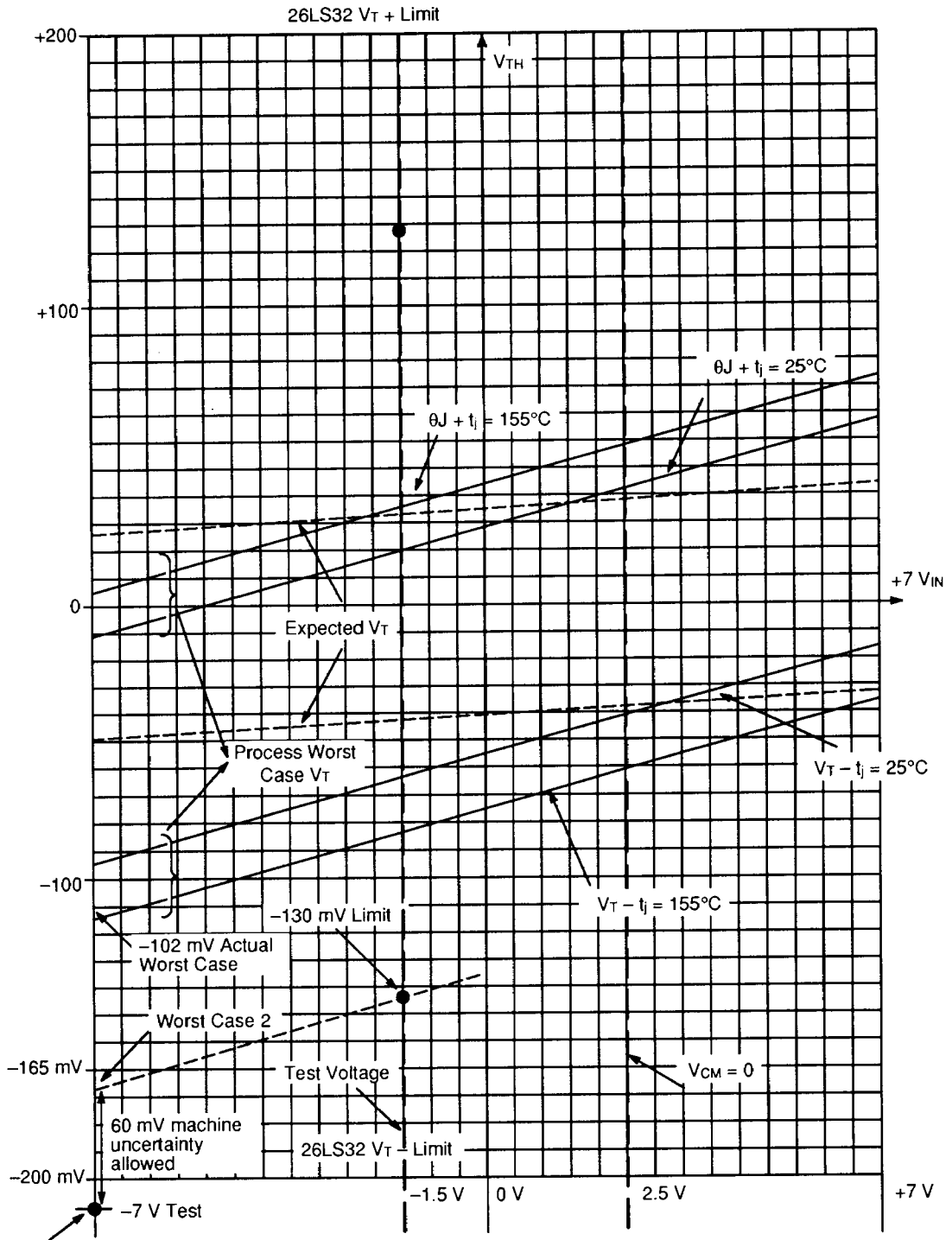

Figure 1. 26LS32 Input Threshold V_T vs. Input Voltage V_{IN}