



Am27C010

1 Megabit (131,072 x 8-Bit) CMOS EPROM

DISTINCTIVE CHARACTERISTICS

- **Fast access time**
 - 55 ns
- **Low power consumption**
 - 20 μ A typical CMOS standby current
- **JEDEC-approved pinout**
- **Single +5 V power supply**
- **$\pm 10\%$ power supply tolerance available**
- **100% Flashrite™ programming**
 - Typical programming time of 16 seconds
- **Latch-up protected to 100 mA from -1 V to $V_{cc} + 1$ V**
- **High noise immunity**
- **Versatile features for simple interfacing**
 - Both CMOS and TTL input/output compatibility
 - Two line control functions
- **Compact 32-pin DIP, PDIP, TSOP, LCC and PLCC packages**
- **DESC SMD No. 5962-89614**

GENERAL DESCRIPTION

The Am27C010 is a 1 Megabit ultraviolet erasable programmable read-only memory. It is organized as 128K words by 8 bits per word, operates from a single +5 V supply, has a static standby mode, and features fast single address location programming. Products are available in windowed ceramic DIP and LCC packages as well as plastic one time programmable (OTP) PDIP, TSOP, and PLCC packages.

Typically, any byte can be accessed in less than 55 ns, allowing operation with high-performance microprocessors without any WAIT states. The Am27C010 offers separate Output Enable (\overline{OE}) and Chip Enable (\overline{CE})

controls, thus eliminating bus contention in a multiple bus microprocessor system.

AMD's CMOS process technology provides high speed, low power, and high noise immunity. Typical power consumption is only 100 mW in active mode, and 100 μ W in standby mode.

All signals are TTL levels, including programming signals. Bit locations may be programmed singly, in blocks, or at random. The Am27C010 supports AMD's Flashrite programming algorithm (100 μ s pulses) resulting in a typical programming time of 16 seconds.

BLOCK DIAGRAM

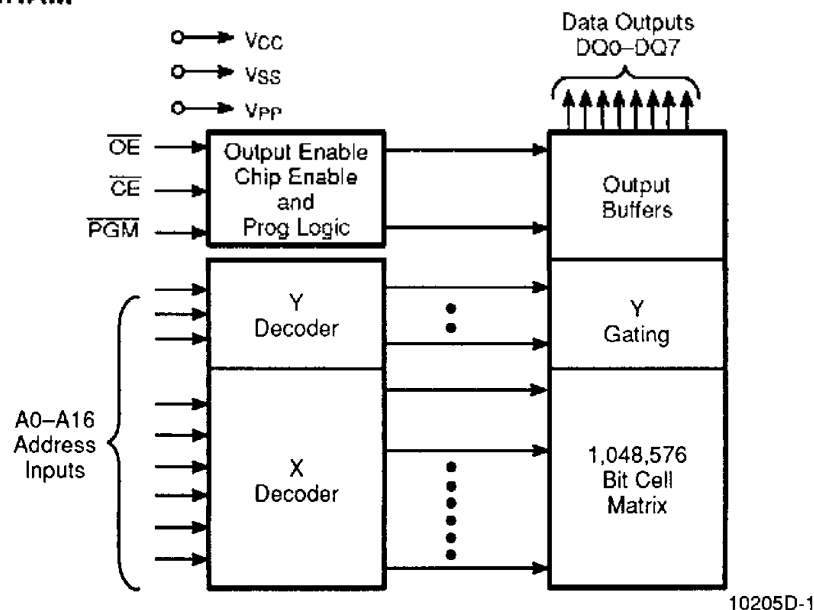

PRODUCT SELECTOR GUIDE

Family Part No.	Am27C010						
	-55	-70	-90	-120	-150	-200	-255
Ordering Part No: V _{cc} ±5%							
V _{cc} ±10%							
Max Access Time (ns)	55	70	90	120	150	200	250
\overline{CE} (\overline{E}) Access (ns)	55	70	90	120	150	200	250
\overline{OE} (\overline{G}) Access (ns)	35	35	50	50	65	75	100

CONNECTION DIAGRAMS

Top View

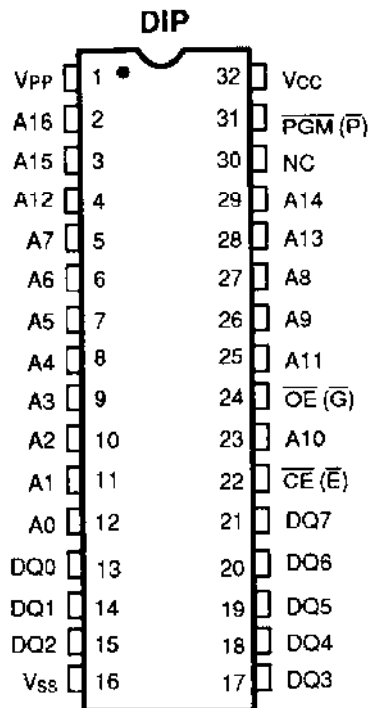

10205D-2

Notes:

1. JEDEC nomenclature is in parentheses.
2. The 32-pin DIP to 32-pin LCC configuration varies from the JEDEC 28-pin DIP to 32-pin LCC configuration.

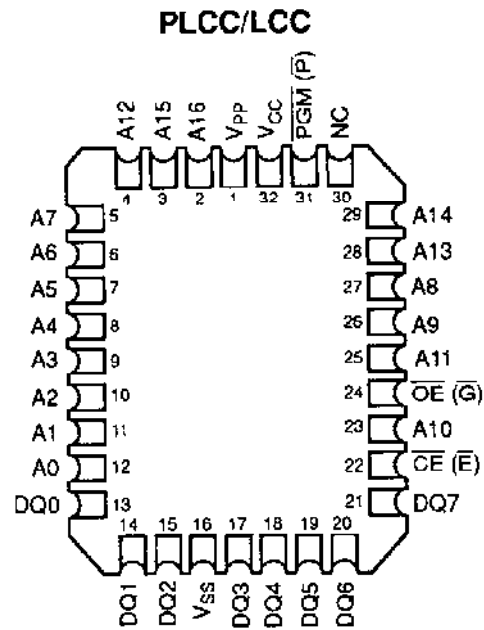

10205D-3

PIN DESIGNATIONS

- A0-A16 = Address Inputs
- \overline{CE} (\overline{E}) = Chip Enable Input
- DQ0-DQ7 = Data Input/Outputs
- \overline{OE} (\overline{G}) = Output Enable Input
- \overline{PGM} (\overline{P}) = Program Enable Input
- Vcc = Vcc Supply Voltage
- Vpp = Program Voltage Input
- Vss = Ground

LOGIC SYMBOL

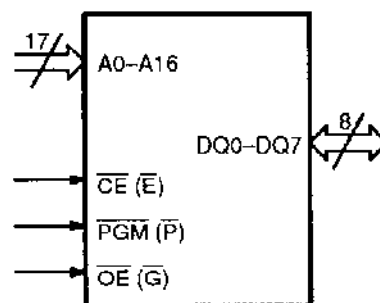

10205D-4

TSOP PACKAGES

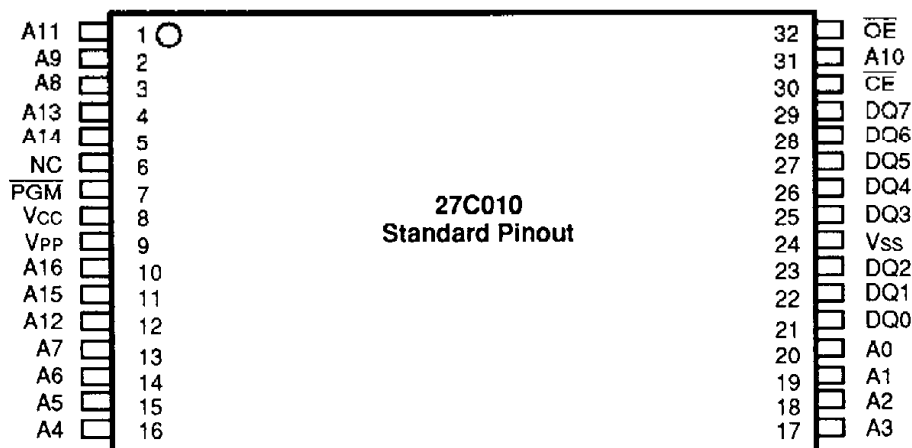

10205D-5

Am27C010 128K x 8 EPROM in 32 Lead TSOP



ORDERING INFORMATION

EPROM Products

AMD Standard products are available in several packages and operating ranges. The order number (Valid Combination) is formed by a combination of:

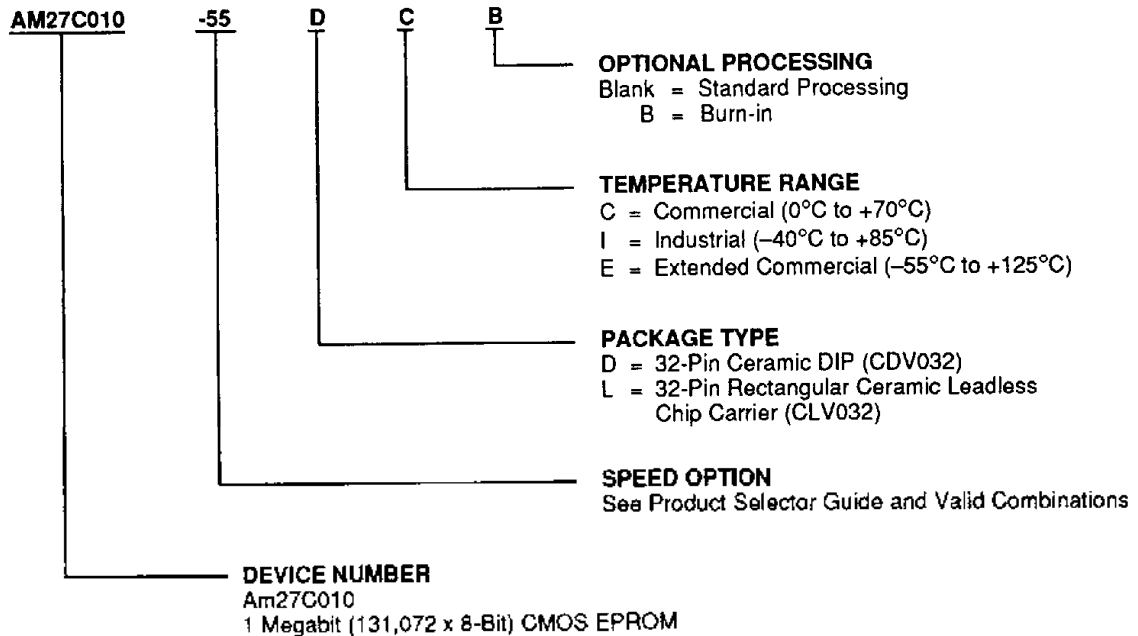

Valid Combinations	
AM27C010-55	DC
AM27C010-70	DC, DCB, DI, DIB,
AM27C010-90	LC, LCB, LI, LIB
AM27C010-120	DC, DCB, DE, DEB,
AM27C010-150	DI, DIB, LC, LCB,
AM27C010-200	LI, LIB, LE, LEB
AM27C010-255	

Valid Combinations

Valid Combinations list configurations planned to be supported in volume for this device. Consult the local AMD sales office to confirm availability of specific valid combinations and to check on newly released combinations.

ORDERING INFORMATION

OTP Products

AMD Standard products are available in several packages and operating ranges. The order number (Valid Combination) is formed by a combination of:

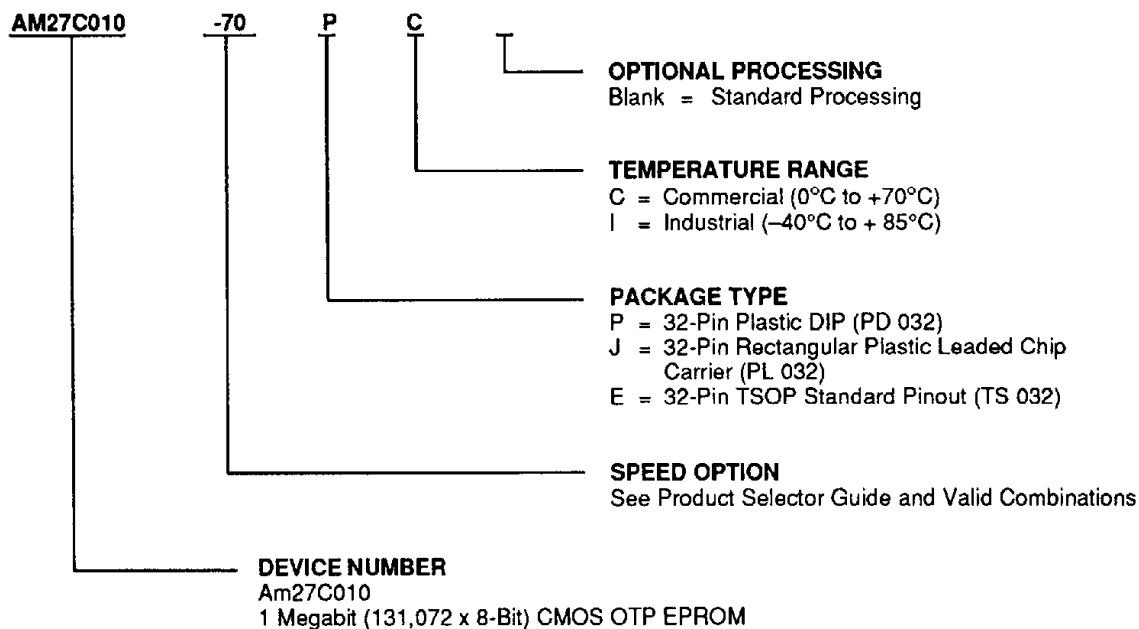

Valid Combinations	
AM27C010-70	PC, JC, EC, PI, JI, EI
AM27C010-90	
AM27C010-120	
AM27C010-150	
AM27C010-200	
AM27C010-255	

Valid Combinations

Valid Combinations list configurations planned to be supported in volume for this device. Consult the local AMD sales office to confirm availability of specific valid combinations and to check on newly released combinations.

ORDERING INFORMATION

Military APL Products

AMD products for Aerospace and Defense applications are available in several packages and operating ranges. APL (Approved Products List) products are fully compliant with MIL-STD-883 requirements. The order number (Valid Combination) is formed by a combination of:

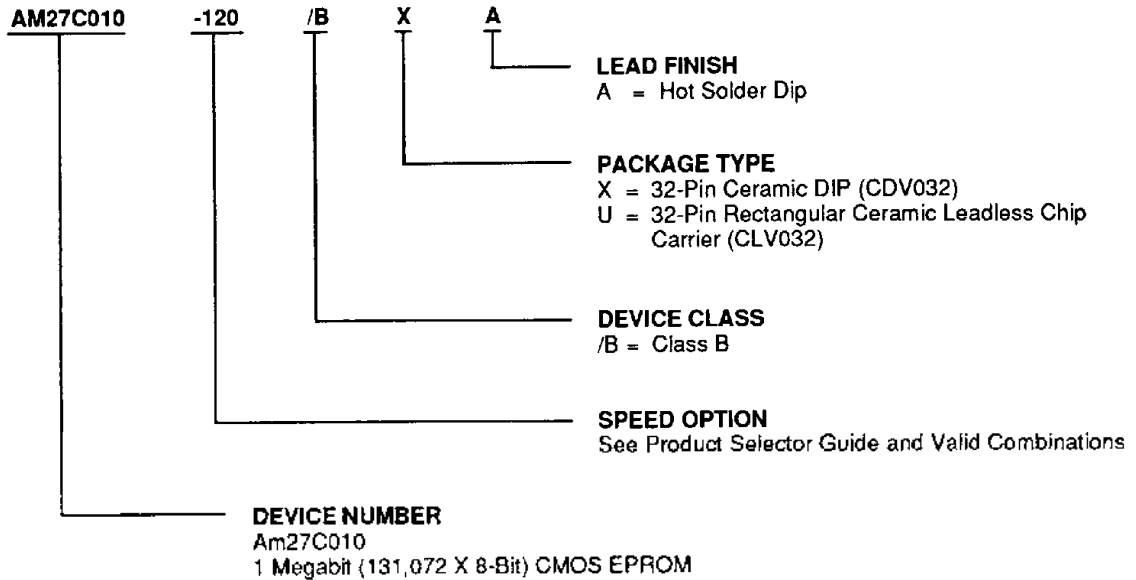

Valid Combinations	
AM27C010-120	/BXA, /BUA
AM27C010-150	
AM27C010-200	
AM27C010-250	

Valid Combinations

Valid Combinations list configurations planned to be supported in volume for this device. Consult the local AMD sales office to confirm availability of specific valid combinations and to check on newly released combinations.

Group A Tests

Group A tests consist of Subgroups
1, 2, 3, 7, 8, 9, 10, 11.

FUNCTIONAL DESCRIPTION

Erasing the Am27C010

In order to clear all locations of their programmed contents, it is necessary to expose the Am27C010 to an ultraviolet light source. A dosage of 15 W seconds/cm² is required to completely erase an Am27C010. This dosage can be obtained by exposure to an ultraviolet lamp—wavelength of 2537 Å—with intensity of 12,000 μW/cm² for 15 to 20 minutes. The Am27C010 should be directly under and about one inch from the source and all filters should be removed from the UV light source prior to erasure.

It is important to note that the Am27C010 and similar devices will erase with light sources having wavelengths shorter than 4000 Å. Although erasure times will be much longer than with UV sources at 2537 Å, exposure to fluorescent light and sunlight will eventually erase the Am27C010 and exposure to them should be prevented to realize maximum system reliability. If used in such an environment, the package window should be covered by an opaque label or substance.

Programming the Am27C010

Upon delivery or after each erasure the Am27C010 has all 1,048,576 bits in the "ONE" or HIGH state. "ZEROS" are loaded into the Am27C010 through the procedure of programming.

The programming mode is entered when 12.75 V ± 0.25 V is applied to the V_{PP} pin, \overline{CE} and \overline{PGM} are at V_{IL}, and \overline{OE} is at V_{IH}.

For programming, the data to be programmed is applied 8 bits in parallel to the data output pins.

The Flashrite algorithm reduces programming time by using 100 μs programming pulses and by giving each address only as many pulses as is necessary in order to reliably program the data. After each pulse is applied to a given address, the data in that address is verified. If the data does not verify, additional pulses are given until it verifies or the maximum is reached. This process is repeated while sequencing through each address of the Am27C010. This part of the algorithm is done at V_{CC} = 6.25 V to assure that each EPROM bit is programmed to a sufficiently high threshold voltage. After the final address is completed, the entire EPROM memory is verified at V_{CC} = V_{PP} = 5.25 V.

Please refer to Section 6 for programming flow chart and characteristics.

Program Inhibit

Programming of multiple Am27C010 in parallel with different data is also easily accomplished. Except for \overline{CE} , all like inputs of the parallel Am27C010 may be common. A TTL low-level program pulse applied to an

Am27C010 \overline{CE} input and V_{PP} = 12.75 V ± 0.25 V, \overline{PGM} Low and \overline{OE} High will program that Am27C010. A high-level \overline{CE} input inhibits the other Am27C010 devices from being programmed.

Program Verify

A verify should be performed on the programmed bits to determine that they were correctly programmed. The verify should be performed with \overline{OE} and \overline{CE} at V_{IL}, \overline{PGM} at V_{IH}, and V_{PP} between 12.5 V and 13.0 V.

Auto Select Mode

The auto select mode allows the reading out of a binary code from an EPROM that will identify its manufacturer and type. This mode is intended for use by programming equipment for the purpose of automatically matching the device to be programmed with its corresponding programming algorithm. This mode is functional in the 25°C ± 5°C ambient temperature range that is required when programming the Am27C010.

To activate this mode, the programming equipment must force 12.0 V ± 0.5 V on address line A9 of the Am27C010. Two identifier bytes may then be sequenced from the device outputs by toggling address line A0 from V_{IL} to V_{IH}. All other address lines must be held at V_{IL} during auto select mode.

Byte 0 (A0 = V_{IL}) represents the manufacturer code, and byte 1 (A0 = V_{IH}), the device code. For the Am27C010, these two identifier bytes are given in the Mode Select Table. All identifiers for manufacturer and device codes will possess odd parity, with the MSB (DQ7) defined as the parity bit.

Read Mode

The Am27C010 has two control functions, both of which must be logically satisfied in order to obtain data at the outputs. Chip Enable (\overline{CE}) is the power control and should be used for device selection. Output Enable (\overline{OE}) is the output control and should be used to gate data to the output pins, independent of device selection. Assuming that addresses are stable, address access time (t_{ACC}) is equal to the delay from \overline{CE} to output (t_{CE}). Data is available at the outputs t_{OE} after the falling edge of \overline{OE} , assuming that \overline{CE} has been LOW and addresses have been stable for at least t_{ACC} - t_{OE}.

Standby Mode

The Am27C010 has a CMOS standby mode which reduces the maximum V_{CC} current to 100 μA. It is placed in CMOS-standby when \overline{CE} is at V_{CC} ± 0.3 V. The Am27C010 also has a TTL-standby mode which reduces the maximum V_{CC} current to 1.0 mA. It is placed in TTL-standby when \overline{CE} is at V_{IH}. When in standby mode, the outputs are in a high-impedance state, independent of the \overline{OE} input.

Output OR-Tieing

To accommodate multiple memory connections, a two-line control function is provided to allow for:

- Low memory power dissipation
- Assurance that output bus contention will not occur

It is recommended that \overline{CE} be decoded and used as the primary device-selecting function, while \overline{OE} be made a common connection to all devices in the array and connected to the READ line from the system control bus. This assures that all deselected memory devices are in low-power standby mode and that the output pins are only active when data is desired from a particular memory device.

System Applications

During the switch between active and standby conditions, transient current peaks are produced on the rising and falling edges of Chip Enable. The magnitude of these transient current peaks is dependent on the output capacitance loading of the device. At a minimum, a 0.1- μ F ceramic capacitor (high frequency, low inherent inductance) should be used on each device between V_{CC} and V_{SS} to minimize transient effects. In addition, to overcome the voltage drop caused by the inductive effects of the printed circuit board traces on EPROM arrays, a 4.7- μ F bulk electrolytic capacitor should be used between V_{CC} and V_{SS} for each eight devices. The location of the capacitor should be close to where the power supply is connected to the array.

MODE SELECT TABLE

Mode		Pins	\overline{CE}	\overline{OE}	\overline{PGM}	A0	A9	V_{PP}	Outputs
Read			V_{IL}	V_{IL}	X	X	X	V_{CC}	DOUT
Output Disable			X	V_{IH}	X	X	X	V_{CC}	Hi-Z
Standby (TTL)			V_{IH}	X	X	X	X	V_{CC}	Hi-Z
Standby (CMOS)			$V_{CC} \pm 0.3 V$	X	X	X	X	V_{CC}	Hi-Z
Program			V_{IL}	V_{IH}	V_{IL}	X	X	V_{PP}	DIN
Program Verify			V_{IL}	V_{IL}	V_{IH}	X	X	V_{PP}	DOUT
Program Inhibit			V_{IH}	X	X	X	X	V_{PP}	Hi-Z
Auto Select (Note 3)	Manufacturer Code		V_{IL}	V_{IL}	X	V_{IL}	V_{H}	V_{CC}	01H
	Device Code		V_{IL}	V_{IL}	X	V_{IH}	V_{H}	V_{CC}	0E

Notes:

1. $V_H = 12.0 V \pm 0.5 V$
2. X = Either V_{IH} or V_{IL}
3. A1-A8 = A10-A16 = V_{IL}
4. See DC Programming Characteristics for V_{PP} voltage during programming.

ABSOLUTE MAXIMUM RATINGS

Storage Temperature	
OTP Products	–65°C to +125°C
All Other Products	–65°C to +150°C
Ambient Temperature	
with Power Applied	–55°C to +125°C
Voltage with Respect To V_{SS}	
All pins except A9, V_{PP} , V_{CC}	–0.6 V to $V_{CC} + 0.5$ V
A9 and V_{PP}	–0.6 V to +13.5 V
V_{CC}	–0.6 V to +7.0 V

Notes:

1. Minimum DC voltage on input or I/O pins is –0.5 V. During transitions, the inputs may overshoot V_{SS} to –2.0 V for periods of up to 20 ns. Maximum DC voltage on input and I/O pins is $V_{CC} + 0.5$ V which may overshoot to $V_{CC} + 2.0$ V for periods up to 20 ns.
2. For A9 and V_{PP} the minimum DC input is –0.5 V. During transitions, A9 and V_{PP} may overshoot V_{SS} to –2.0 V for periods of up to 20 ns. A9 and V_{PP} must not exceed 13.5 V for any period of time.

Stresses above those listed under “Absolute Maximum Ratings” may cause permanent damage to the device. This is a stress rating only; functional operation of the device at these or any other conditions above those indicated in the operational sections of this specification is not implied. Exposure of the device to absolute maximum rating conditions for extended periods may affect device reliability.

OPERATING RANGES**Commercial (C) Devices**

Case Temperature (T_C) 0°C to +70°C

Industrial (I) Devices

Case Temperature (T_C) –40°C to +85°C

Extended Commercial (E) Devices

Case Temperature (T_C) –55°C to +125°C

Military (M) Devices

Case Temperature (T_C) –55°C to +125°C

Supply Read Voltages

V_{CC} for Am27C010-XX5 +4.75 V to +5.25 V

V_{CC} for Am27C010-XX0 +4.50 V to +5.50 V

V_{CC} for Am27C010-55 +4.75 V to +5.25 V

Operating ranges define those limits between which the functionality of the device is guaranteed.

DC CHARACTERISTICS over operating range unless otherwise specified.
 (Notes 1, 2, and 4) (for APL Products, Group A, Subgroups 1, 2, 3, 7, and 8 are tested unless otherwise noted)

Parameter Symbol	Parameter Description	Test Conditions	Min	Max	Unit
V _{OH}	Output HIGH Voltage	I _{OH} = -400 μA	2.4		V
V _{OL}	Output LOW Voltage	I _{OL} = 2.1 mA		0.45	V
V _{IH}	Input HIGH Voltage		2.0	V _{CC} + 0.5	V
V _{IL}	Input LOW Voltage		-0.5	+0.8	V
I _{I1}	Input Load Current	V _{IN} = 0 V to V _{CC}		1.0	μA
I _{LO}	Output Leakage Current	V _{OUT} = 0 V to V _{CC}		5.0	μA
I _{CC1}	V _{CC} Active Current (Note 3)	$\overline{CE} = V_{IL}, f = 10 \text{ MHz}, I_{OUT} = 0 \text{ mA}$	C/I Devices	30	mA
			E/M Devices	60	
I _{CC2}	V _{CC} TTL Standby Current	$\overline{OE} = V_{IH}$		1.0	mA
I _{CC3}	V _{CC} CMOS Standby Current	$\overline{OE} = V_{CC} \pm 0.3 \text{ V}$		100	μA
I _{PP1}	V _{PP} Current During Read	$\overline{CE} = \overline{OE} = V_{IL}, V_{PP} = V_{CC}$		100	μA

Notes:

- V_{CC} must be applied simultaneously or before V_{PP}, and removed simultaneously or after V_{PP}.
- Caution:** The Am27C010 must not be removed from (or inserted into) a socket when V_{CC} or V_{PP} is applied.
- I_{CC1} is tested with $\overline{OE} = V_{IH}$ to simulate open outputs.
- Minimum DC Input Voltage is -0.5 V. During transitions, the inputs may overshoot to -2.0 V for periods less than 20 ns. Maximum DC Voltage on output pins is V_{CC} + 0.5 V, which may overshoot to V_{CC} + 2.0 V for periods less than 20 ns.

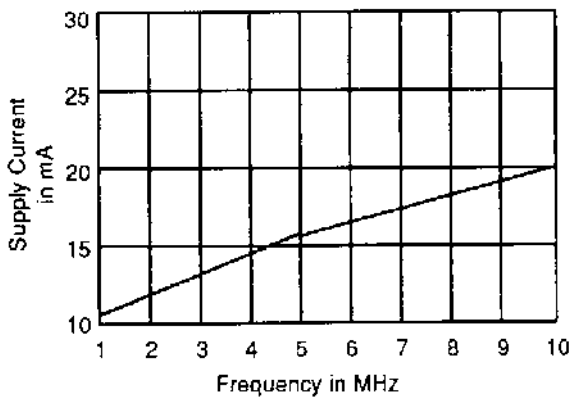

Figure 1. Typical Supply Current vs. Frequency
 V_{CC} = 5.5 V, T = 25°C

10205D-6

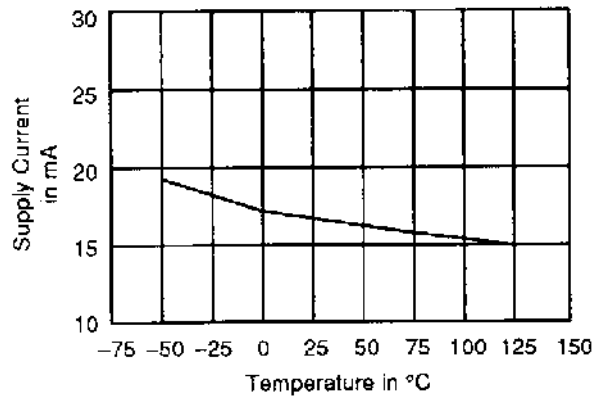

Figure 2. Typical Supply Current vs. Temperature
 V_{CC} = 5.5 V, f = 5 MHz

10205D-7

CAPACITANCE

Parameter Symbol	Parameter Description	Test Conditions	CLV032		CDV032		PL 032		PD 032		TS 032		Unit
			Typ	Max	Typ	Max	Typ	Max	Typ	Max	Typ	Max	
C _{IN}	Input Capacitance	V _{IN} = 0	9	12	9	12	8	12	8	12	10	12	pF
C _{OUT}	Output Capacitance	V _{OUT} = 0	11	14	13	15	11	14	11	14	12	14	pF

Notes:

1. This parameter is only sampled and not 100% tested.

SWITCHING CHARACTERISTICS over operating range unless otherwise specified (Notes 1, 3, and 4) (for APL Products, Group A, Subgroups 9,10, and 11 are tested unless otherwise noted)

Parameter Symbols		Parameter Description	Test Conditions	Am27C010							Unit	
JEDEC	Standard			-55	-70	-90	-120	-150	-200	-255 -250		
tAVQV	tACC	Address to Output Delay	$\overline{CE} = \overline{OE} = V_{IL}$	Min	-	-	-	-	-	-	-	
				Max	55	70	90	120	150	200	250	ns
tELOV	tCE	Chip Enable to Output Delay	$\overline{OE} = V_{IL}$	Min	-	-	-	-	-	-	-	
				Max	55	70	90	120	150	200	250	ns
tGLQV	tOE	Output Enable to Output Delay	$\overline{CE} = V_{IL}$	Min	-	-	-	-	-	-	-	
				Max	35	35	40	50	65	75	75	ns
tEHQZ tGHQZ	tDF (Note 2)	Chip Enable HIGH or Output Enable HIGH, whichever comes first, to Output Float		Min	-	-	-	-	-	-	-	
				Max	25	25	25	35	35	40	40	ns
tAXQX	tOH	Output Hold from Addresses, \overline{CE} , or \overline{OE} , whichever occurred first		Min	0	0	0	0	0	0	0	
				Max	-	-	-	-	-	-	-	ns

Notes:

1. V_{CC} must be applied simultaneously or before V_{PP}, and removed simultaneously or after V_{PP}.
2. This parameter is only sampled and not 100% tested.
3. **Caution:** The Am27C010 must not be removed from (or inserted into) a socket or board when V_{PP} or V_{CC} is applied.
4. Output Load: 1 TTL gate and C_L = 100 pF
 Input Rise and Fall Times: 20 ns
 Input Pulse Levels: 0.45 V to 2.4 V
 Timing Measurement Reference Level: 0.8 V and 2 V for inputs and outputs

SWITCHING TEST CIRCUIT

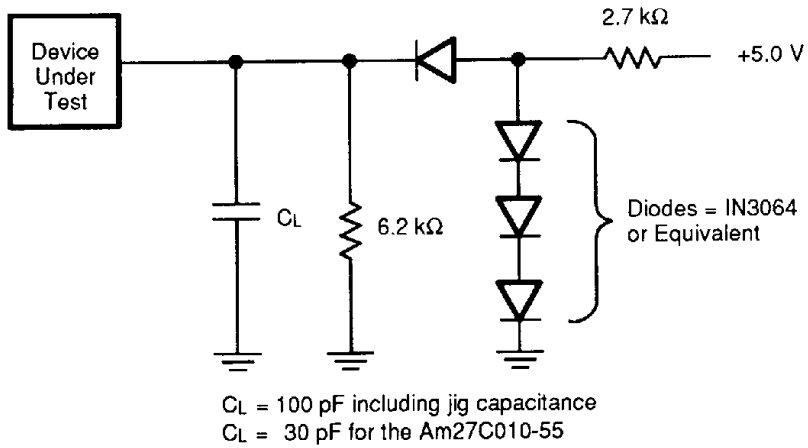

SWITCHING TEST WAVEFORM

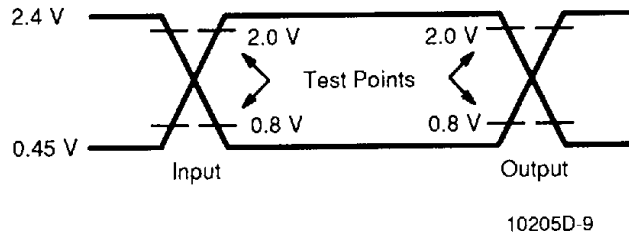

AC Testing: Inputs are driven at 2.4 V for a logic "1" and 0.45 V for a logic "0". Input pulse rise and fall times are ≤ 20 ns.

KEY TO SWITCHING WAVEFORMS

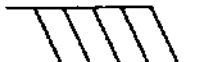
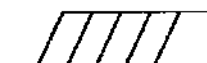
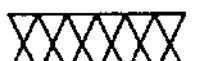
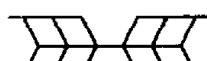
WAVEFORM	INPUTS	OUTPUTS
	Must Be Steady	Will Be Steady
	May Change from H to L	Will Be Changing from H to L
	May Change from L to H	Will Be Changing from L to H
	Don't Care, Any Change Permitted	Changing State Unknown
	Does Not Apply	Center Line is High Impedence "Off" State

KS000010

SWITCHING WAVEFORMS

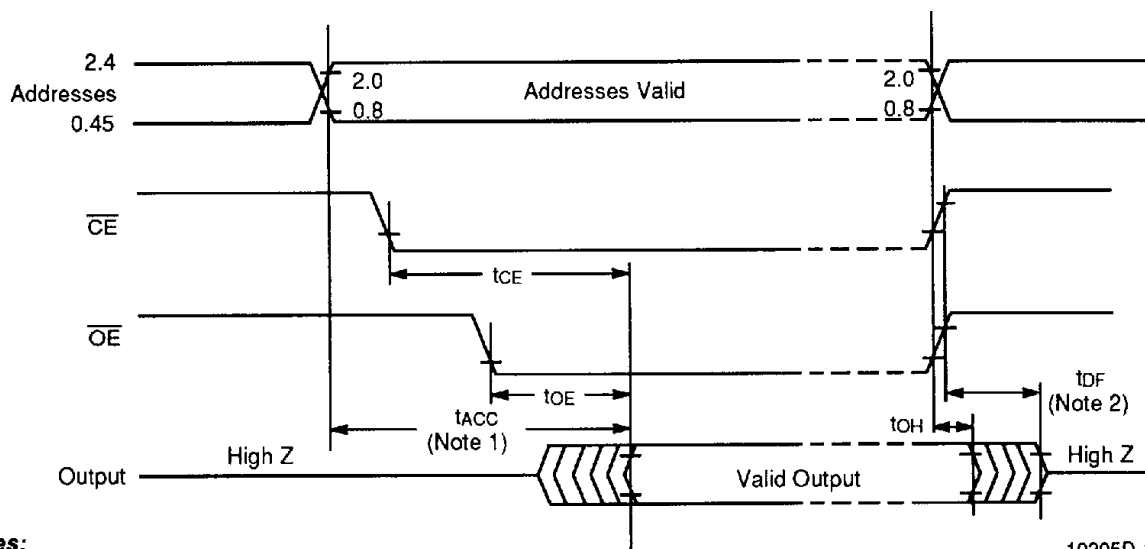

Notes:

- \overline{OE} may be delayed up to $t_{ACC} - t_{OE}$ after the falling edge of the addresses without impact on t_{ACC} .
- t_{DF} is specified from \overline{OE} or \overline{CE} , whichever occurs first.

10205D-10

PHYSICAL DIMENSIONS*

CDV032

32-Pin Ceramic DIP (measured in inches)

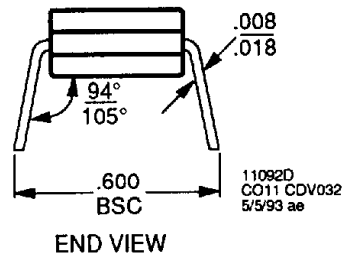
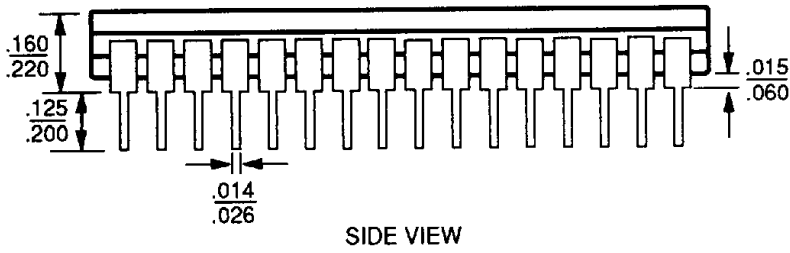
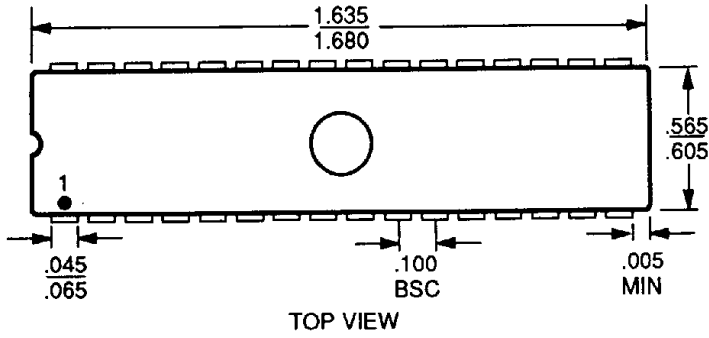

*For reference only. BSC is an ANSI standard for Basic Space Centering.

PHYSICAL DIMENSIONS

CLV032

32-Pin Rectangular Ceramic

Leadless Chip Carrier (measured in inches)

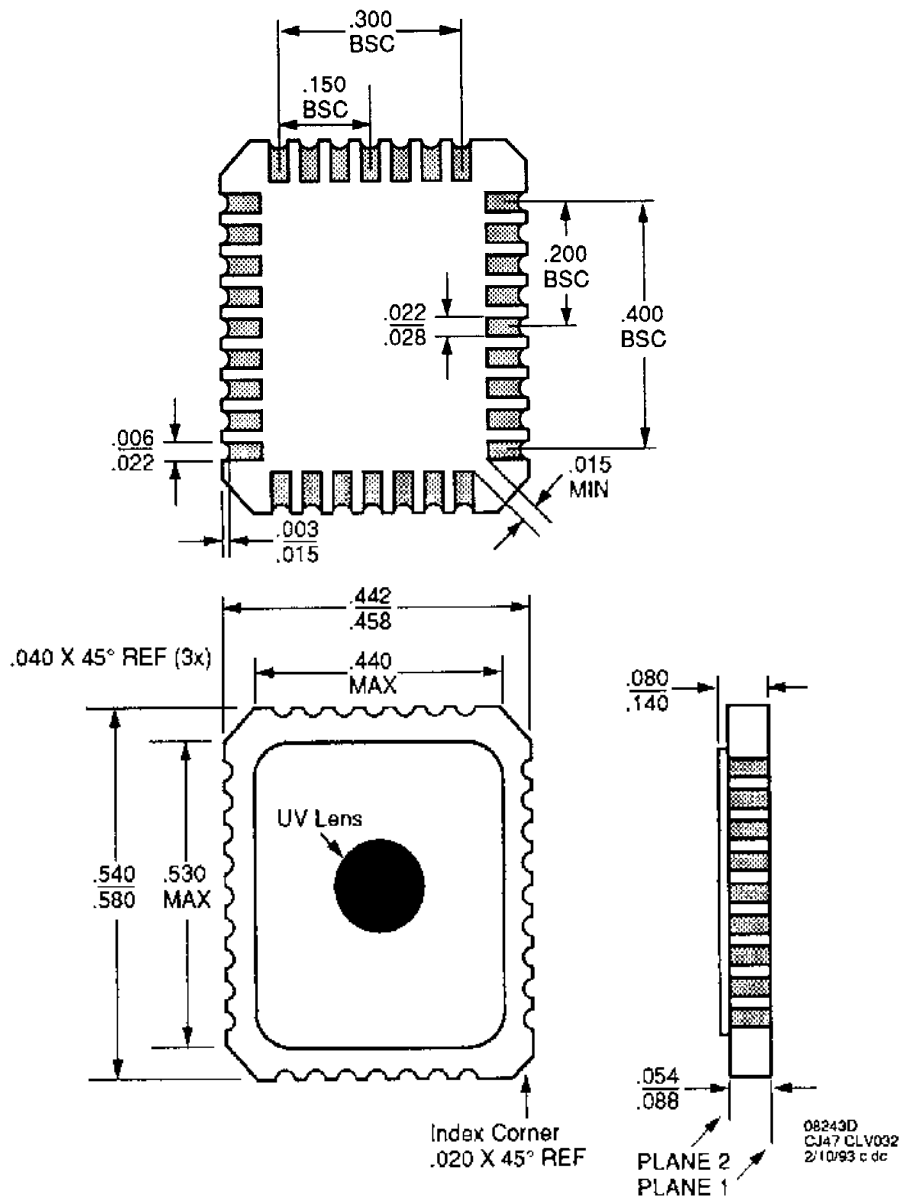

PHYSICAL DIMENSIONS

PD 032

32-Pin Plastic DIP (measured in inches)

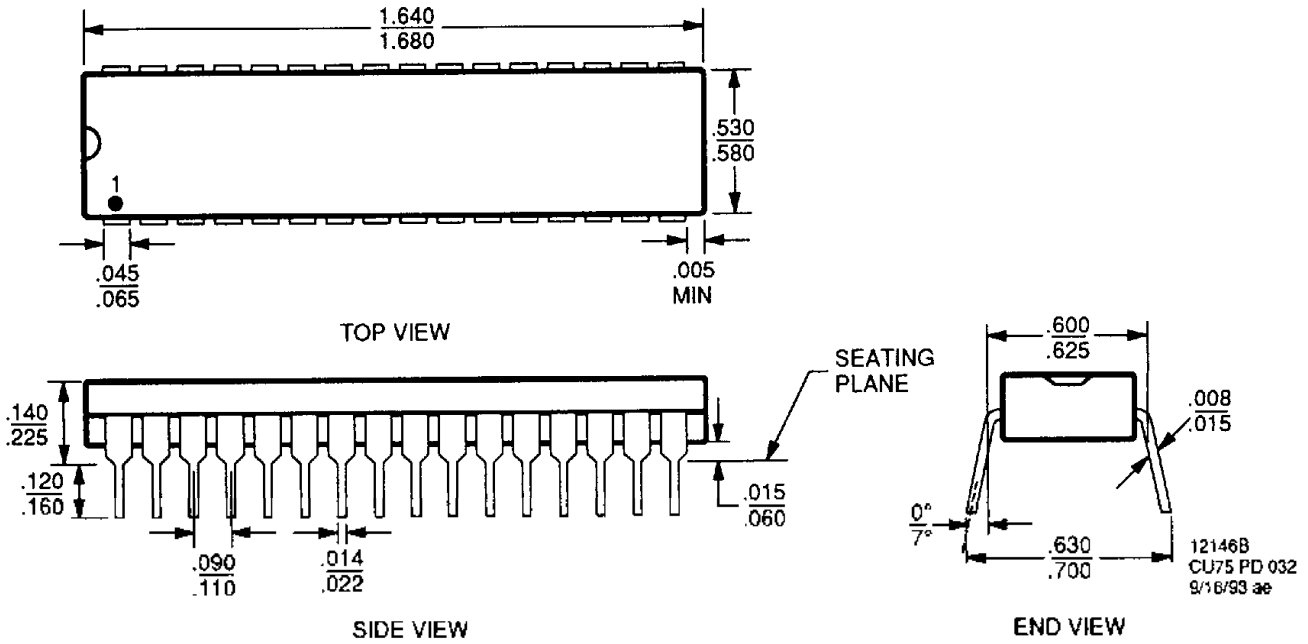

PL 032

32-Pin Rectangular Plastic

Leaded Chip Carrier (measured in inches)

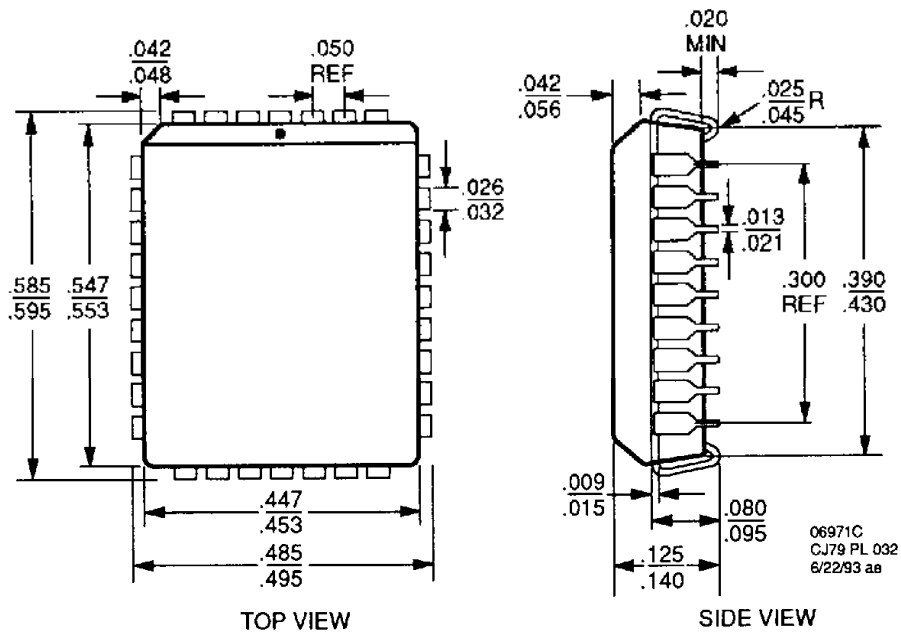

PHYSICAL DIMENSIONS

TS 032

32-Pin TSOP Standard Pinout (measured in millimeters)

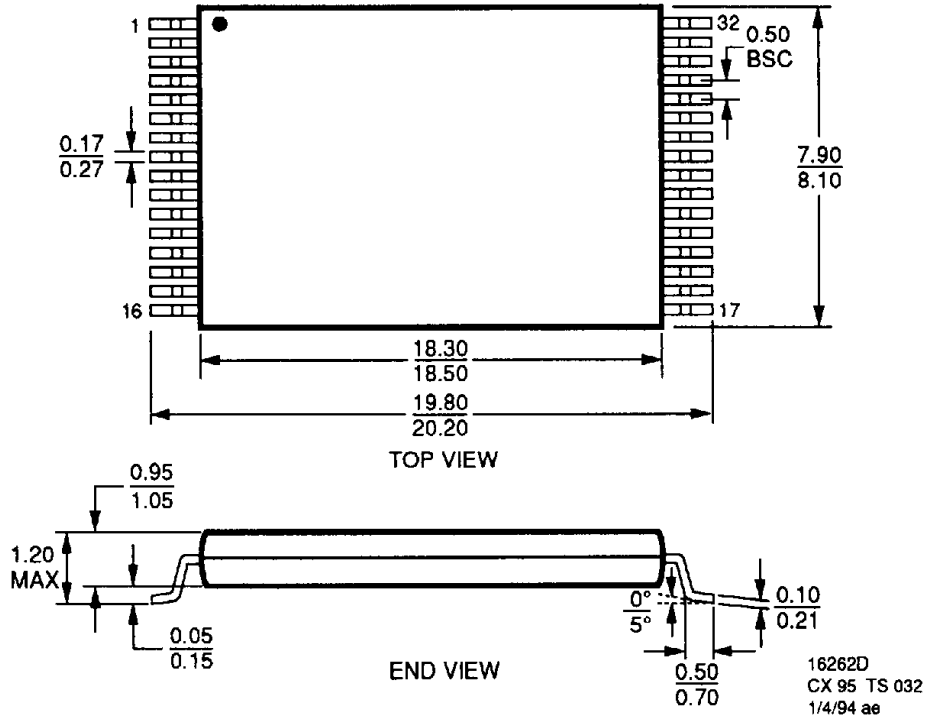

Trademarks

Copyright © 1994 Advanced Micro Devices, Inc. All rights reserved.

AMD, and the AMD logo are registered trademarks, and Flashrite is a trademark of Advanced Micro Devices, Inc.

Product names used in this publication are for identification purposes only and may be trademarks of their respective companies.

Sales Offices

North American

ALABAMA	(205) 882-9122
ARIZONA	(602) 242-4400
CALIFORNIA,	
Culver City	(310) 645-1524
Newport Beach	(714) 752-6262
Sacramento(Roseville)	(916) 786-6700
San Diego	(619) 560-7030
San Jose	(408) 922-0500
Woodland Hills	(818) 878-9988
CANADA, Ontario,	
Kanata	(613) 592-0060
Willowdale	(416) 222-7800
COLORADO	(303) 741-2900
CONNECTICUT	(203) 264-7800
FLORIDA,	
Clearwater	(813) 530-9971
Boca Raton	(407) 361-0050
Orlando (Longwood)	(407) 862-9292
GEORGIA	(404) 449-7920
IDAHO	(208) 377-0393
ILLINOIS,	
Chicago (Itasca)	(708) 773-4422
Naperville	(708) 505-9517
MARYLAND	(301) 381-3790
MASSACHUSETTS	(617) 273-3970
MINNESOTA	(612) 938-0001
NEW JERSEY,	
Cherry Hill	(609) 662-2900
Parsippany	(201) 299-0002
NEW YORK,	
Brewster	(914) 279-8323
Rochester	(716) 425-8050
NORTH CAROLINA	
Charlotte	(704) 875-3091
Raleigh	(919) 878-8111
OHIO,	
Columbus (Westerville)	(614) 891-6455
Dayton	(513) 439-0268
OREGON	(503) 245-0080
PENNSYLVANIA	(215) 398-8006
TEXAS,	
Austin	(512) 346-7830
Dallas	(214) 934-9099
Houston	(713) 376-8084

International

BELGIUM, Antwerpen	TEL	(03) 248 43 00
	FAX	(03) 248 46 42
FRANCE, Paris	TEL	(1) 49-75-10-10
	FAX	(1) 49-75-10-13
GERMANY,		
Bad Homburg	TEL	(06172)-24061
	FAX	(06172)-23195
München	TEL	(089) 45053-0
	FAX	(089) 406490
HONG KONG,		
Wanchai	TEL	(852) 865-4525
	FAX	(852) 865-4335
ITALY, Milano	TEL	(02) 3390541
	FAX	(02) 38103458
JAPAN,		
Tokyo	TEL	(03) 3346-7550
	FAX	(03) 3342-5196
Osaka	TEL	(06) 243-3250
	FAX	(06) 243-3253
KOREA, Seoul	TEL	(82) 2-784-0030
	FAX	(82) 2-784-8014

International (Continued)

LATIN AMERICA,		
Ft. Lauderdale	TEL	(305) 484-8600
	FAX	(305) 485-9736
SINGAPORE	TEL	(65) 3481188
	FAX	(65) 3480161
SWEDEN,		
Stockholm area	TEL	(08) 98 61 80
(Bromma)	FAX	(08) 98 09 06
TAIWAN, Taipei	TEL	(886) 2-7153536
	FAX	(886) 2-7122183
UNITED KINGDOM,		
Manchester area	TEL	(0925) 830380
(Warrington)	FAX	(0925) 830204
London area	TEL	(0483) 740440
(Woking)	FAX	(0483) 756196

North American Representatives

CANADA		
Burnaby, B.C. - DAVETEK MARKETING	(604) 430-3680	
Kanata, Ontario - VITEL ELECTRONICS	(613) 592-0060	
Mississauga, Ontario -		
VITEL ELECTRONICS	(905) 564-9720	
Lachina, Quebec - VITEL ELECTRONICS	(514) 636-5951	
ILLINOIS		
Skokie - INDUSTRIAL		
REPRESENTATIVES, INC.	(708) 967-8430	
IOWA		
LORENZ SALES	(319) 377-4666	
KANSAS		
Merriam - LORENZ SALES	(913) 469-1312	
Wichita - LORENZ SALES	(316) 721-0500	
MEXICO		
Chula Vista - SONIKA ELECTRONICA	(619) 498-8340	
Guadalajara - SONIKA ELECTRONICA	(523) 647-4250	
Mexico City - SONIKA ELECTRONICA	(523) 754-6480	
Monterrey - SONIKA ELECTRONICA	(523) 358-9280	
MICHIGAN		
Holland - COM-TEK SALES, INC.	(616) 335-8418	
Brighton - COM-TEK SALES, INC.	(313) 227-0007	
MINNESOTA		
Mel Foster Tech. Sales, Inc.	(612) 941-9790	
MISSOURI		
LORENZ SALES	(314) 997-4558	
NEBRASKA		
LORENZ SALES	(402) 475-4660	
NEW MEXICO		
THORSON DESERT STATES	(505) 883-4343	
NEW YORK		
East Syracuse - NYCOM, INC.	(315) 437-8343	
Hauppauge - COMPONENT		
CONSULTANTS, INC.	(516) 273-5050	
OHIO		
Centerville - DOLFUSS ROOT & CO.	(513) 433-6776	
Westlake - DOLFUSS ROOT & CO.	(216) 899-9370	
PENNSYLVANIA		
RUSSELL F. CLARK CO., INC.	(412) 242-9500	
PUERTO RICO		
COMP REP ASSOC, INC.	(809) 746-6550	
UTAH		
FRONT RANGE MARKETING	(801) 288-2500	
WASHINGTON		
ELECTRA TECHNICAL SALES	(206) 821-7442	
WISCONSIN		
Brookfield - INDUSTRIAL		
REPRESENTATIVES, INC.	(414) 574-9393	

Advanced Micro Devices reserves the right to make changes in its product without notice in order to improve design or performance characteristics. The performance characteristics listed in this document are guaranteed by specific tests, guard banding, design and other practices common to the industry. For specific testing details, contact your local AMD sales representative. The company assumes no responsibility for the use of any circuits described herein.



RECYCLED & RECYCLABLE



Advanced Micro Devices, Inc. 901 Thompson Place, P.O. Box 3453, Sunnyvale, CA 94088, USA
 Tel: (408) 732-2400 • TWX: 910-339-9280 • TELEX: 34-6306 • TOLL FREE: (800) 538-8450
 APPLICATIONS HOTLINE & LITERATURE ORDERING • TOLL FREE: (800) 222-9323 • (408) 749-5703

© 1994 Advanced Micro Devices, Inc.
 CP-8.3M-5/94-0
 10205E
 4/7/94
 Printed in USA