

ADC2300E Audio A/D Converter Europe (24-Pin Plastic Package)

Analog-to-digital converter for digitizing the analog sound signals in a digital TV receiver with stereo sound channel to European standard. The ADC2300E is an integrated circuit in CI technology and contains on one silicon chip the following functions:

- two pulse-density modulators
- five analog switches for selecting different signal sources
- the analog stereo dematrix circuit
- the IM bus interface circuit acting as receiver for commands given by the CCU2030, CCU2050 or CCU2070 Central Control Unit to control the dematrix and the analog switches

Functional Description

The analog sound signals selected for conversion by the analog switches S1 are fed to the pulse-density modulators PDM I and PDM II. The output signals of these are 1-bit data streams having a rate of 4.7 MHz maximum. This data is then transferred to the APU2400T Audio Processor where the digital audio filter is at the front end, performing the second step of the conversion process. The digital output data of the whole converting system has a signal-to-noise ratio which can be compared to that of a conventional 13-bit A/D converter.

The five analog switches S1 to S5 are controlled via the IM bus to select the required connections between the four analog inputs and the two digital outputs and the two additional analog outputs.

When switched on via the IM bus, the dematrix provides the 2R and the 2L-signals for stereo at the analog outputs. These signals are extracted from the L+R and 2R input signals according to the German TV stereo sound system.

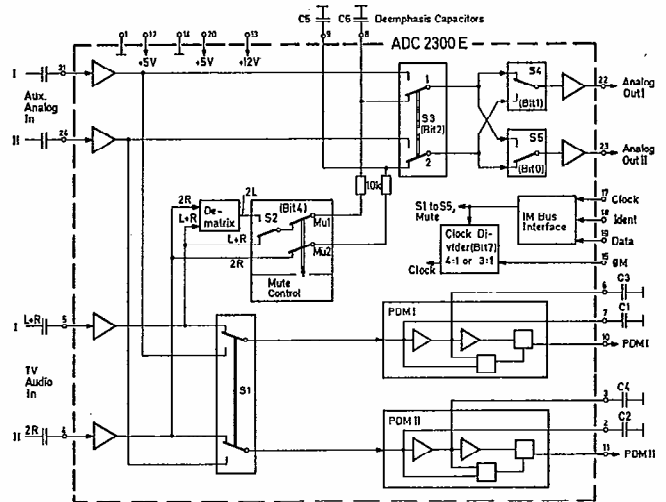

ADC2300E Block Diagram

The pulse-density modulators, PDM I and PDM II, are sigma-delta modulators equipped with two feedback loops. At the outputs they supply pulse trains whose pulse density is proportional to the amplitude of the input signal. The maximum sampling rate, and thus the maximum pulse rate, is 4.7 MHz.

ADC2310E Audio A/D Converter Europe (24-Pin Plastic Package)

Analog-to-digital converter for digitizing the analog stereo sound signals in digital TV receivers based on the DIGIT2000 system, intended for working together with the APU2400T or the APU2470 Audio Processor, being controlled by the CCU2030, CCU2050 or CCU2070 Central Control Unit and clocked by the MCU2632 Clock Generator. The ADC2310E is an integrated circuit in CI technology, and contains on one silicon chip the following functions:

- several analog input and output amplifiers
- five analog switches (S1 to S5) for selecting different signal sources
- an analog stereo dematrix circuit
- a level control facility
- two pulse-density modulators (PDM I and PDM II)
- an IM bus interface

Functional Description

The analog sound signals selected for conversion by the analog switch S1 firstly pass through the level control section where the desired level control is carried out. Thereafter, they are fed to the first processing stage of the A/D conversion, the pulse-density modulators PDM I and PDM II, whose output signals are 1-bit data streams with a data rate of 4.7 MHz maximum. This data is then transferred to the APU Audio Processor where the digital decimation filters are the input, performing the second step of the conversion process. Due to the very high sampling rate of the pulse-density modulators, no steep anti-aliasing filters are needed at the input. The digital output data of the whole converting system has a signal-to-noise ratio which can be compared to that of a conventional 13-bit A/D converter.

The TV Audio inputs get their analog signal (L + R and 2 R) from the stereo decoder of the TV set, whereas the Aux. Analog inputs are intended to receive an audio signal from a video recorder or another external source, e.g. via the SCART connector. The Analog Out I and II

pins supply the selected audio signal, e.g., to the SCART connector for connection to a video recorder or other equipment.

The five analog switches S1 to S5 (S1 and S3 are two-pole switches) are controlled via the IM bus to select the required connections between the four analog inputs and the two digital outputs and the two additional analog outputs.

The level control section serves to reduce the level of the input signal to be converted if the input signal exceeds the level for full drive of the PDM pulse-density modulators.

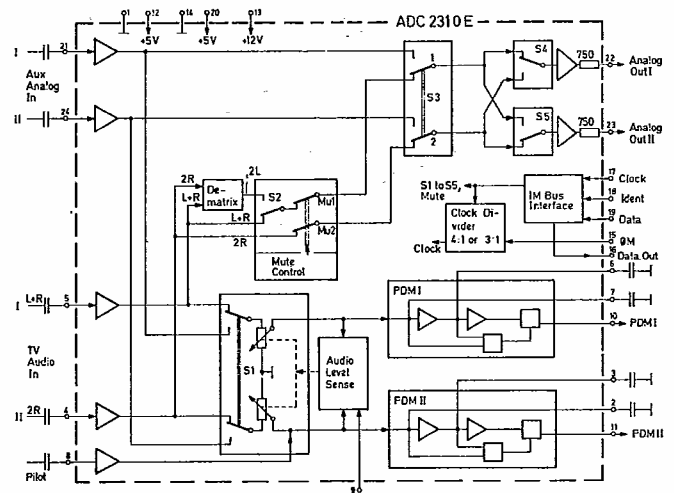

ADC2310 Block Diagram