

PRODUCT NUMBER
SEE TABLE

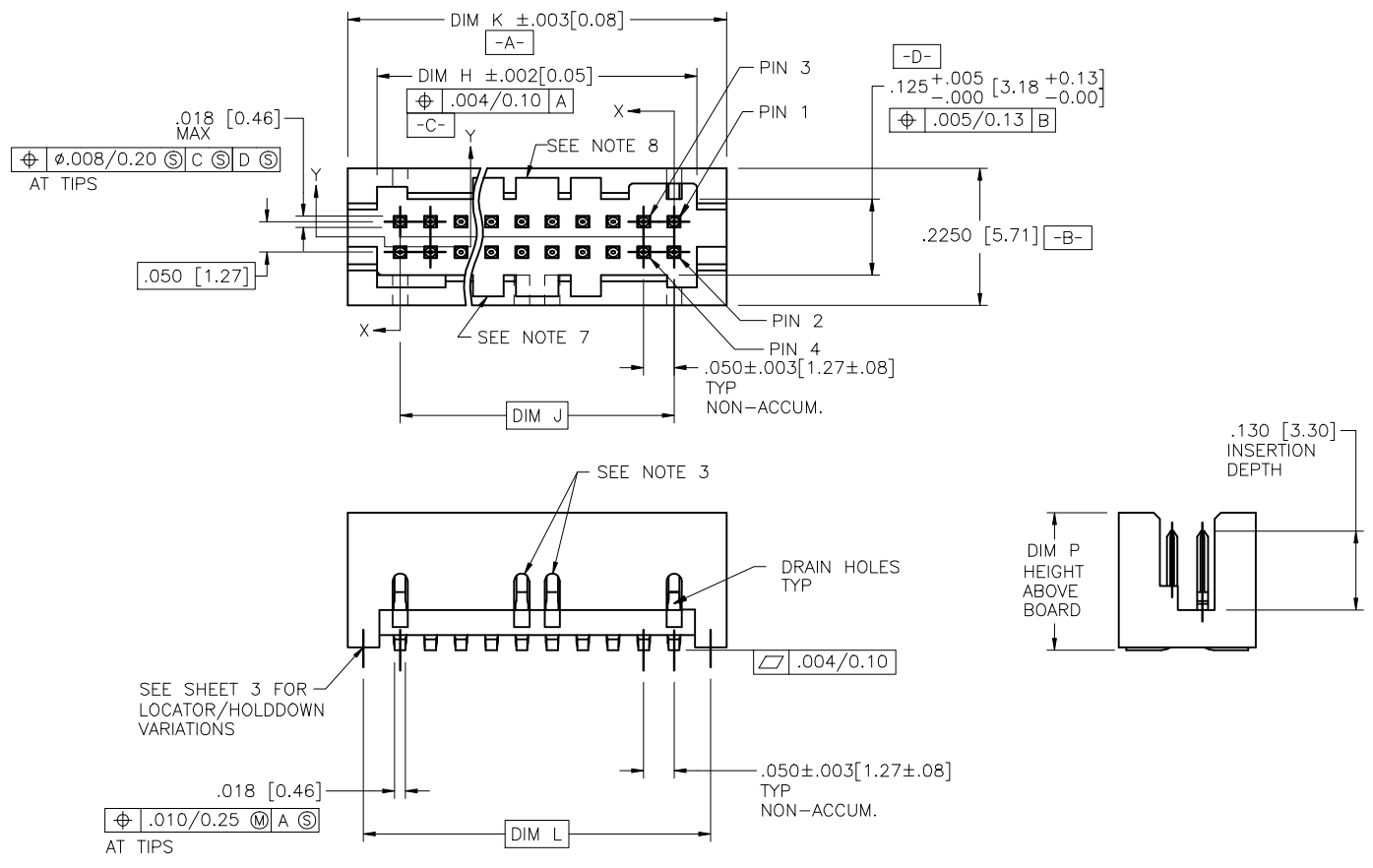

SEE SHEET 3 FOR LOCATOR/HOLDDOWN VARIATIONS



FCIconnect.com

Copyright FCI

mat'l. code SEE NOTES				surface ISO 1302	tolerance ISO 406 ISO 1101	projection INCH/MM	product family RIB CAGE
ltr	ec'n no	dr	date	tolerances unless otherwise specified		scale 1:1	title RIB CAGE III SMT VERT. HEADER ASS'Y
V	V10329	CRG	6/06/01	linear	XX ±.01/XX±0.3		dwg no 95781
W	V04-0004	DAL	1/21/04	∠±z	XXX±.005/XXX±0.13	sheet 1 of 6	size A3
X	M05-0084	MHT	5/05/05		XXX±.002/XXX±0.051		
Y	M06-0284	AEA	7/27/06	dr	M. CORNMAN	6/07/95	
AA	M08-0245	MHT	8/27/08	engr	D. WHITING	6/07/95	
AB	M09-0058	MHT	4/02/09	chr	D. WHITING	6/07/95	
AC	M09-0087	MHT	6/10/09	appd	D. WHITING	6/07/95	
sheet	revision	AC	AC	AC	AC	AC	
index	sheet	1	2	3	4	5	6

PRODUCT NUMBER
SEE TABLE

SIZE	DIM H	DIM J	DIM K	DIM L
2X5	.275/6.99	.200/5.08	.372/9.45	.320/8.13
2X10	.525/13.34	.450/11.43	.622/15.80	.570/14.48
2X15	.775/19.68	.700/17.78	.872/22.15	.820/20.83
2X20	1.025/26.03	.950/24.13	1.122/28.50	1.070/27.18
2X25	1.275/32.38	1.200/30.48	1.372/34.85	1.320/33.53
2X30	1.525/38.74	1.450/36.83	1.622/41.20	1.570/39.88
2X35	1.775/45.08	1.700/43.18	1.872/47.55	1.820/46.23
2X40	2.025/51.43	1.950/49.53	2.122/53.90	2.070/52.58
2X45	2.275/57.78	2.200/55.88	2.372/60.25	2.320/58.93
2X50	2.525/64.14	2.450/62.23	2.622/66.60	2.570/65.28

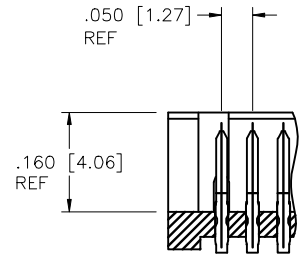
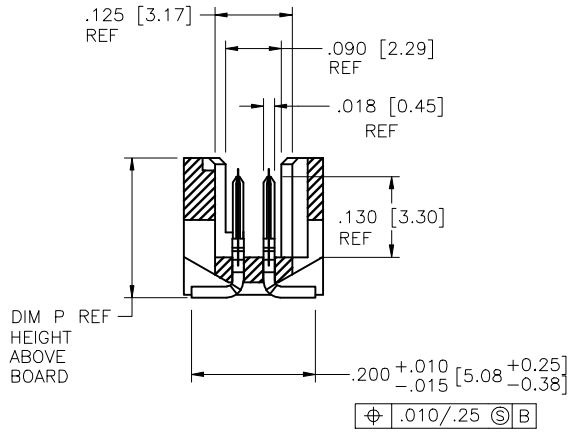

SECTION Y-Y

SECTION X-X
ROTATED 90° CW

mat'l. code SEE NOTES		surface ISO 1302	tolerance ISO 406 ISO 1101	projection FIRST ANGLE	product family RIB CAGE
l/r	ec'n no	dr	date	INCH/MM	title RIB CAGE III SMT VERT. HEADER ASS'Y
AC				linear	scale 1:1
				angular	dwg no 95781
				radius	sheet 2 of 6 size A3
				fillet	type Product Customer Drawing
				thread	
dr	M. CORNMAN	6/07/95			
engr	D. WHITING	6/07/95			
chr	D. WHITING	6/07/95			
appd	D. WHITING	6/07/95			
sheet index	revision sheet				



FCconnect.com

Copyright FCJ

PRODUCT NUMBER
SEE TABLE

LOCATOR/HOLDDOWN VARIATIONS

STYLE
1



STYLE
5

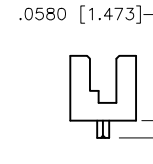
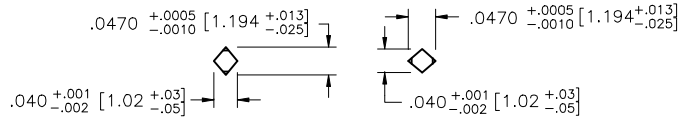
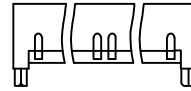

STYLE
2

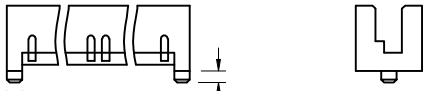

STYLE
6
SEE NOTE 9

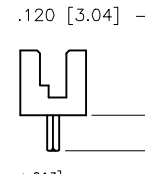
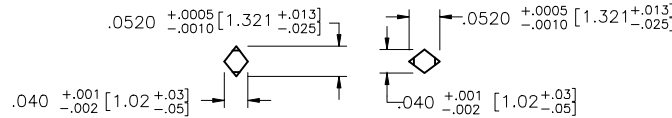
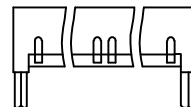

STYLE
3

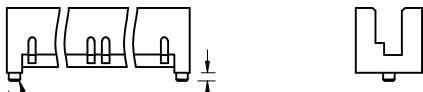

STYLE
7

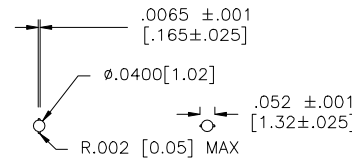
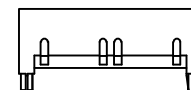

STYLE
4

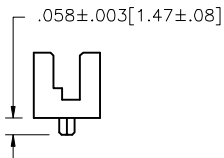
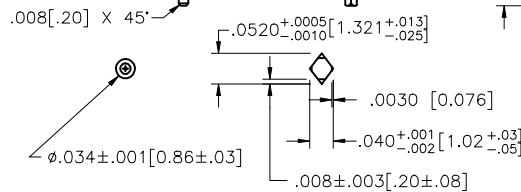
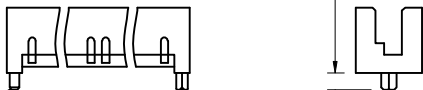

mat'l. code SEE NOTES				surface ISO 1302	tolerance ISO 406 ISO 1101	projection	product family RIB CAGE
litr	ecm no	dr	date	tolerances unless otherwise specified		INCH/MM	title
AC				angles	linear		scale 1:1
				σ±z	linear		dwg no
							sheet 3 of 6
				dr	M. CORNMAN	6/07/95	size
				engr	D. WHITING	6/07/95	A3
				chr	D. WHITING	6/07/95	
				appd	D. WHITING	6/07/95	
sheet	revision						type
index	sheet						Product Customer Drawing



FCJconnect.com

Copyright FCJ

form: A3

PRODUCT NUMBER
SEE TABLE

RECOMMENDED PCB MOUNTING PAD PATTERN

STYLE
1

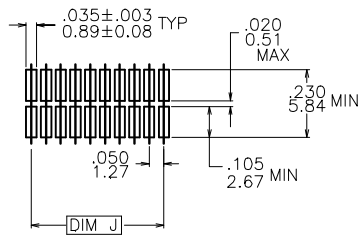

STYLE
5

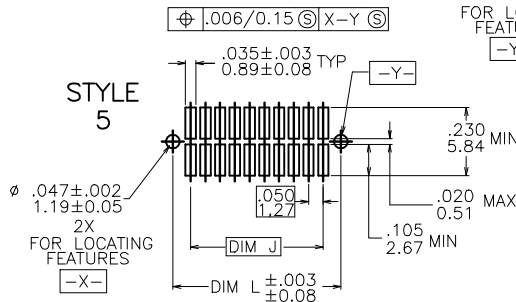

STYLE
4

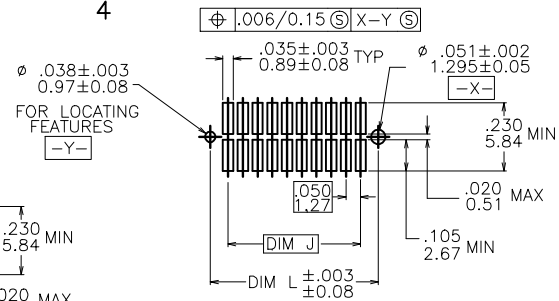

STYLE
6

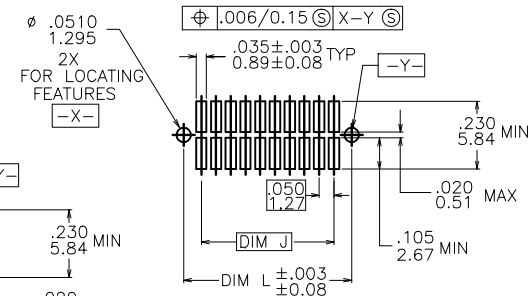

STYLE
2

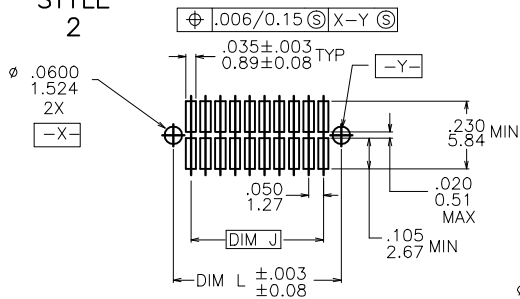

STYLE
7

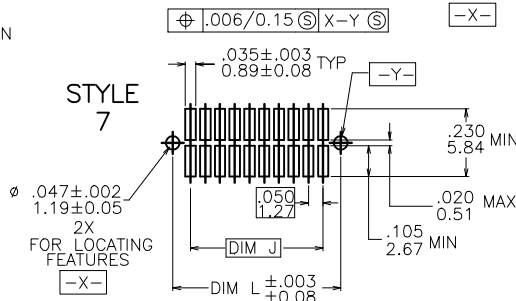

STYLE
3

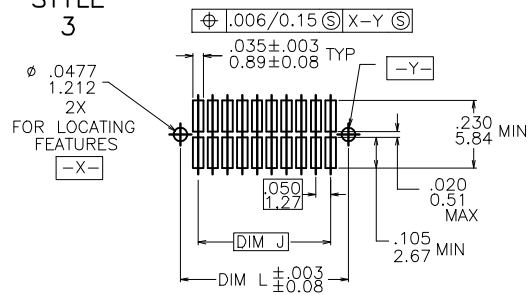

mat'l. code		surface		tolerance		projection		product family	
SEE NOTES		ISO 1302		ISO 406 ISO 1101				RIB CAGE	
ltr	ecrn no	dr	date	tolerances unless otherwise specified				title	
AC				angles	linear	XX ±01/XX±0.3	INCH/MM		RIB CAGE III SMT
				σ±z		XXX±005/XXX±0.13	scale 1:1		VERT. HEADER ASS'Y
				dr	M. CORNMAN	6/07/95	dwg no		sheet 4 of 6 size
				engr	D. WHITING	6/07/95	95781		A3
				chr	D. WHITING	6/07/95	type		Product Customer Drawing
				appd	D. WHITING	6/07/95			
sheet	revision								
index	sheet								



FCIconnect.com

Copyright FCI

form A3

PRODUCT NUMBER NOTE 1,4A & 4B	DIM P HEIGHT ABOVE BOARD (REF.)	HOLDDOWN STYLE
72428-1XX	.244/6.20	1
73546-1XX	.364/9.25	1
73547-1XX	.364/9.25	2
73548-1XX	.364/9.25	4
84700-1XX	.226/5.74	7
84701-1XX	.298/7.57	7
84734-1XX	.364/9.25	7
87401-1XX	.226/5.74	6
87409-1XX	.226/5.74	2
87849-1XX	.226/5.74	1
88566-1XX	.260/6.60	2
90098-1XX	.298/7.57	2
90863-1XX	.226/5.74	1
91036-1XX	.364/9.25	5
91423-1XX	.226/5.74	2
91855-1XX	.226/5.74	5
92099-1XX	.226/5.74	4
92412-1XX	.298/7.57	4
93206-1XX	.226/5.74	3
93221-1XX	.298/7.57	1
93289-1XX	.298/7.57	5

TABLE A

* CUSTOMER SPECIAL

SEE NOTE 10

*

NOTES:

- ① XXXXX-XXXLF
LEAD FREE OPTION (NOTE 11& 13)
NUMBER OF POSITIONS (NOTE 2)
- ② NUMBER OF POSITIONS = 05 THRU 50 IN 5 POS INCREMENTS.
(EXAMPLE : 105=10 POS., 110=20 POS. ETC.)
- ③ REQUIRED ON -X40,-X45 & -X50 POSITION PARTS ONLY.
4. PACKAGING :
A. ANTISTATIC TUBES. SEE TABLE A
B. ADD "CT" TO END OF DASH NUMBER FOR CONNECTOR
WITH VACUUM CAP IN ANTISTATIC TUBES.
EX. : XXXXX-1XXCT
C. PRESSURE SEALED TAPE AND REEL. SEE TABLE C
FOR AVAILABLE PART NUMBERS.
- ⑤ HOUSING MATERIAL :
GLASS FILLED THERMOPLASTIC FLAME RETARDANT PER UL 94V-0.
COLOR : NATURAL
- ⑥ TERMINAL PLATING :
30u"/.76u HARD Au OVER 50u"/1.27u Ni ON CONTACT ZONES.
100u"/2.54u TIN LEAD OVER 50u"/1.27u Ni IN SOLDERING ZONES.
LEAD FREE OPTION:
30u"/.76u HARD Au OVER 50u"/1.27u Ni ON CONTACT ZONES.
100u"/2.54u PURE TIN OVER 50u"/1.27u Ni IN SOLDERING ZONES.
- ⑦ MOLDING FLOW RESTRICTOR QUANTITY AND LOCATION IS
MANUFACTURING OPTION.
- ⑧ VACUUM CAP SLOT REQUIRED ON ALL SIZES, SLOT MAY
BE LOCATED ON OPPOSITE SIDE FOR 2 X 5.
- ⑨ STYLE 6 IS NOT AVAILABLE IN TAPE AND REEL.
- ⑩ 90863-1XX IS PACKAGED ONLY IN TAPE AND REEL.
- ⑪ ADD LF SUFFIX AT THE END OF PART NUMBER FOR LEAD FREE OPTION.
12. THE HOUSING WILL WITHSTAND EXPOSURE TO 260°C PEAK TEMPERATURE
FOR 20 SECONDS IN A CONVECTION, INFRA-RED OR VAPOR PHASE REFLOW
OVEN. SEE APPLICATION NOTE/PROCEDURES IF THEY ARE AVAILABLE.
- ⑬ THIS PRODUCT MEETS EUROPEAN UNION DIRECTIVES AND OTHER
COUNTRY REGULATION AS DESCRIBED IN GS-22-008.



FCJconnect.com

Copyright FCJ

mat'l. code		surface		tolerance		projection		product family	
SEE NOTES		ISO 1302		ISO 406 ISO 1101				RIB CAGE	
l/r	ecm no	dr	date	tolerances unless otherwise specified		INCH/MM		title	
AC				angles	linear	XX ±01/XX±0.3 XXX±.005/XXX±0.13		RIB CAGE III SMT	
				σ±z		XXX±.002/XXX±0.051		VERT. HEADER ASS'Y	
				dr	M. CORNMAN	6/07/95		dwg no	
				engr	D. WHITING	6/07/95		sheet 5 of 6 size	
				chr	D. WHITING	6/07/95		95781 A3	
				appd	D. WHITING	6/07/95		type Product Customer Drawing	
sheet	revision								
index	sheet								

form A3

PRODUCT NUMBER NOTE 11,4C	QTY. REEL	TAPE WIDTH PITCH MM	CONNECTOR ORIENTATION IN TAPE POCKET
72428-120TR	500	44/12	VIEW 1
73547-110TR		24/12	
84700-105TR		24/12	
84700-135TR		56/12	
87409-115TR		44/12	
87409-120TR		44/12	
87409-125TR		56/12	
87409-130TR		56/12	
87409-140TR		72/12	
87849-110TR		24/12	
87849-115TR		44/12	
87849-120TR		44/12	
87849-125TR		56/12	
87849-130TR	500	56/12	
88566-110TR	750	24/12	
88566-115TR	500	44/12	
88566-130TR	500	56/12	
90863-110		24/12	
90863-115		44/12	VIEW 1
90863-115REV		44/12	VIEW 2 *
90863-120		44/12	VIEW 1
90863-125		56/12	
90863-130		56/12	
91036-110P		24/16	
93206-115TR		44/12	
93221-105TR		24/12	
93221-110TR		32/12	
93221-125TR	500	56/12	VIEW 1

TABLE C

* CUSTOMER SPECIAL
NO VACUUM CAP

REFERENCE ONLY :

TAPE WIDTH 32mm AND ABOVE HAS BOTH FEED TRACKS,
BELOW 32mm HAS TOP FEED TRACK ONLY.

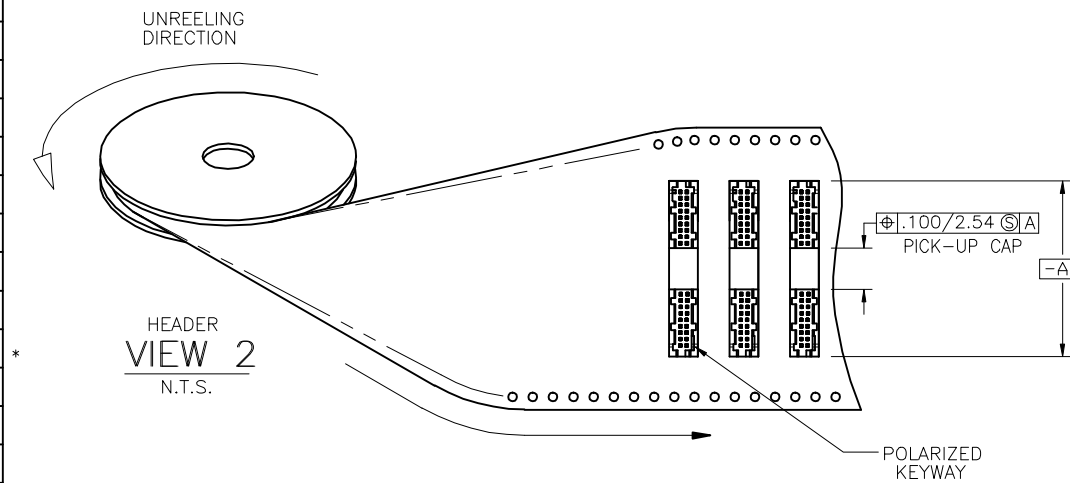
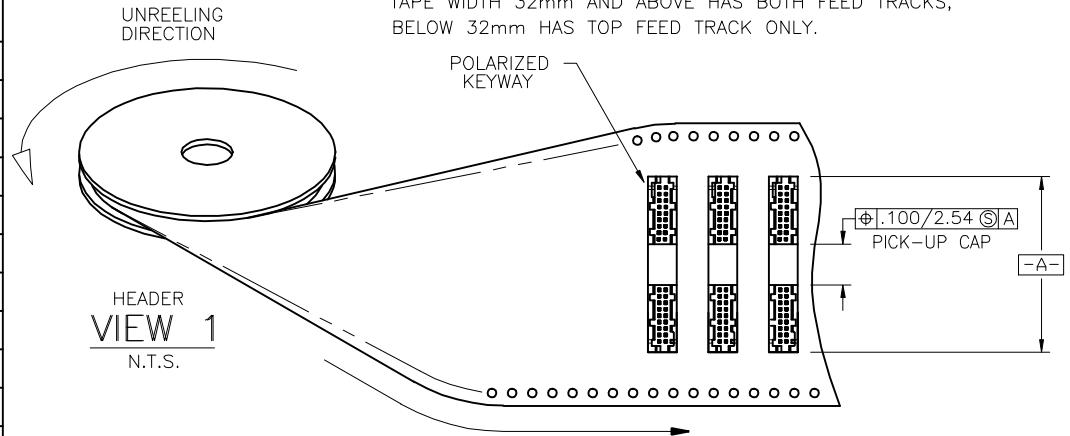

mat'l. code SEE NOTES		surface ISO 1302	tolerance ISO 406 ISO 1101	projection FIRST ANGLE	product family RIB CAGE
ltr	ecn no	dr	date	tolerances unless otherwise specified	title RIB CAGE III SMT VERT. HEADER ASS'Y
AC				angles linear XX ±01/XX±0.3 XXX±.005/XXX±0.13 XXXX±.0020/XXX±0.051	INCH/MM
				scale 1:1	dwg no 95781
		dr	M. CORNMAN	6/07/95	sheet 6 of 6 size A3
		engr	D. WHITING	6/07/95	type Product Customer Drawing
		chr	D. WHITING	6/07/95	
		appd	D. WHITING	6/07/95	
sheet index	revision sheet				