



# MCS<sup>®</sup> 51

## 8-BIT CONTROL-ORIENTED MICROCONTROLLERS

*Commercial/Express*

**8031AH/8051AH/8051AHP  
8032AH/8052AH  
8751H/8751H-8  
8751BH/8752BH**

- |  |  |
|--|--|
| <ul style="list-style-type: none"> <li>■ High Performance HMOS Process</li> <li>■ Internal Timers/Event Counters</li> <li>■ 2-Level Interrupt Priority Structure</li> <li>■ 32 I/O Lines (Four 8-Bit Ports)</li> <li>■ 64K External Program Memory Space</li> <li>■ Security Feature Protects EPROM Parts Against Software Piracy</li> </ul> | <ul style="list-style-type: none"> <li>■ Boolean Processor</li> <li>■ Bit-Addressable RAM</li> <li>■ Programmable Full Duplex Serial Channel</li> <li>■ 111 Instructions (64 Single-Cycle)</li> <li>■ 64K External Data Memory Space</li> <li>■ Extended Temperature Range (-40°C to +85°C)</li> </ul> |
|--|--|

2

The MCS<sup>®</sup> 51 controllers are optimized for control applications. Byte-processing and numerical operations on small data structures are facilitated by a variety of fast addressing modes for accessing the internal RAM. The instruction set provides a convenient menu of 8-bit arithmetic instructions, including multiply and divide instructions. Extensive on-chip support is provided for one-bit variables as a separate data type, allowing direct bit manipulation and testing in control and logic systems that require Boolean processing.

The 8751H is an EPROM version of the 8051AH. It has 4 Kbytes of electrically programmable ROM which can be erased with ultraviolet light. It is fully compatible with the 8051AH but incorporates one additional feature: a Program Memory Security bit that can be used to protect the EPROM against unauthorized readout. The 8751H-8 is identical to the 8751H but only operates up to 8 MHz.

The 8051AHP is identical to the 8051AH with the exception of the Protection Feature. To incorporate this Protection Feature, program verification has been disabled and external memory accesses have been limited to 4K.

The 8052AH is an enhanced version of the 8051AH. It is backwards compatible with the 8051AH and is fabricated with HMOS II technology. The 8052AH enhancements are listed in the table below. Also refer to this table for the ROM, ROMless and EPROM versions of each product.

Device	Internal Memory		Timers/ Event Counters	Interrupts
	Program	Data		
8031AH	none	128 x 8 RAM	2 x 16-Bit	5
8051AH	4K x 8 ROM	128 x 8 RAM	2 x 16-Bit	5
8051AHP	4K x 8 ROM	128 x 8 RAM	2 x 16-Bit	5
8751H	4K x 8 EPROM	128 x 8 RAM	2 x 16-Bit	5
8751H-8	4K x 8 EPROM	128 x 8 RAM	2 x 16-Bit	5
8751BH	4K x 8 EPROM	128 x 8 RAM	2 x 16-Bit	5
8032AH	none	256 x 8 RAM	3 x 16-Bit	6
8052AH	8K x 8 ROM	256 x 8 RAM	3 x 16-Bit	6
8752BH	8K x 8 EPROM	256 x 8 RAM	3 x 16-Bit	6

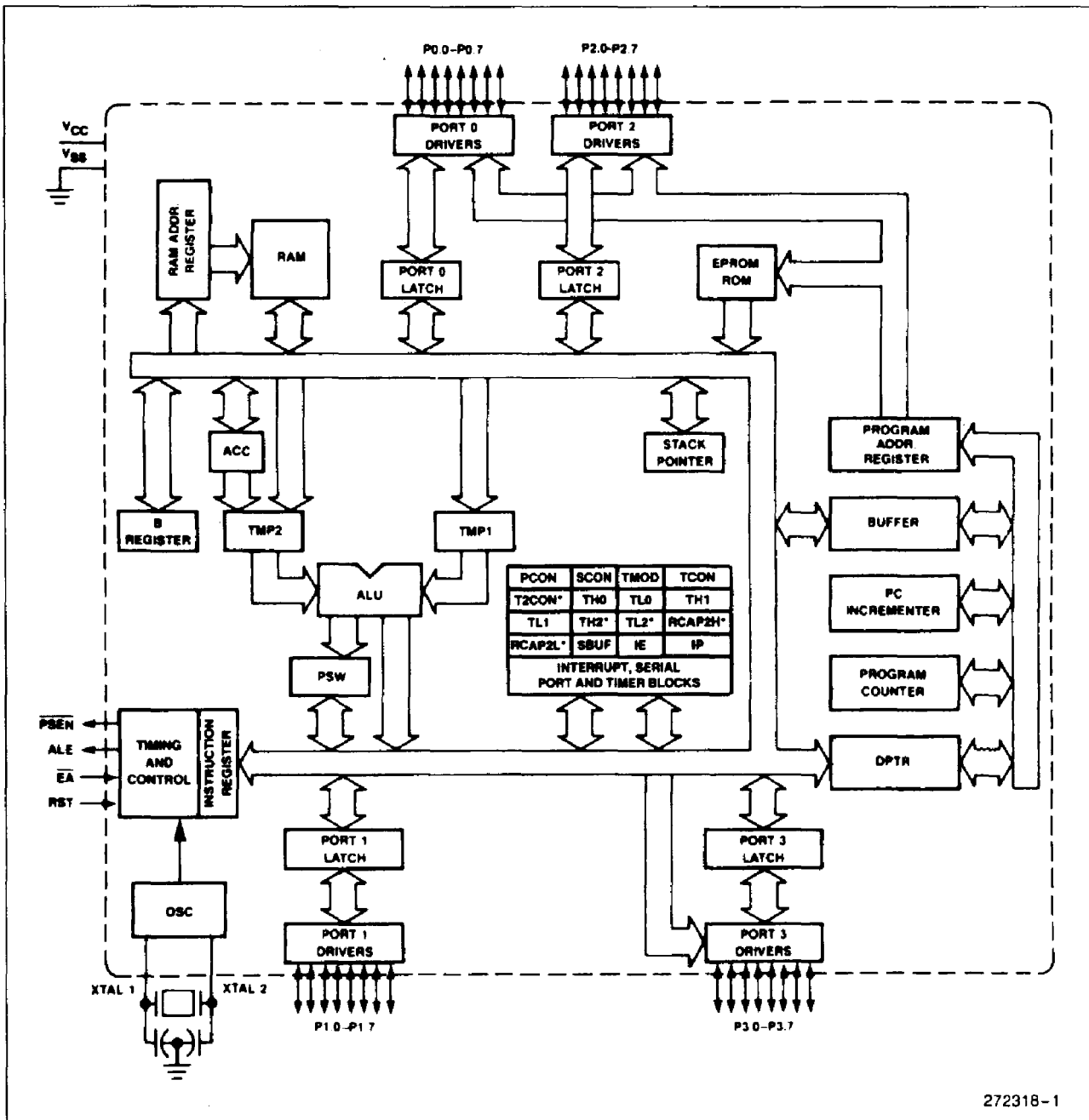

Figure 1. MCS® 51 Controller Block Diagram

### PROCESS INFORMATION

The 8031AH/8051AH and 8032AH/8052AH devices are manufactured on P414.1, an HMOS II process. The 8751H/8751H-8 devices are manufactured on P421.X, an HMOS-E process. The 8751BH and 8752BH devices are manufactured on P422. Additional process and reliability information is available in Intel's *Components Quality and Reliability Handbook*, Order No. 210997.

**PACKAGES**

Part	Prefix	Package Type	$\theta_{ja}$	$\theta_{jc}$
8051AH	P	40-Pin Plastic DIP	45°C/W	16°C/W
8031AH	D	40-Pin CERDIP	45°C/W	15°C/W
8052AH	N	44-Pin PLCC	46°C/W	16°C/W
8032AH				
8752BH*				
8751H	D	40-Pin CERDIP	45°C/W	15°C/W
8751H-8				
8051AHP	P	40-Pin Plastic DIP	45°C/W	16°C/W
	D	40-Pin CERDIP	45°C/W	15°C/W
8751BH	P	40-Pin Plastic DIP	36°C/W	12°C/W
	N	44-Pin PLCC	47°C/W	16°C/W

2

**NOTE:**

\*8752BH is 36°/10° for D, and 38°/22° for N.

All thermal impedance data is approximate for static air conditions at 1W of power dissipation. Values will change depending on operating conditions and application. See the Intel *Packaging Handbook* (Order Number 240800) for a description of Intel's thermal impedance test methodology.

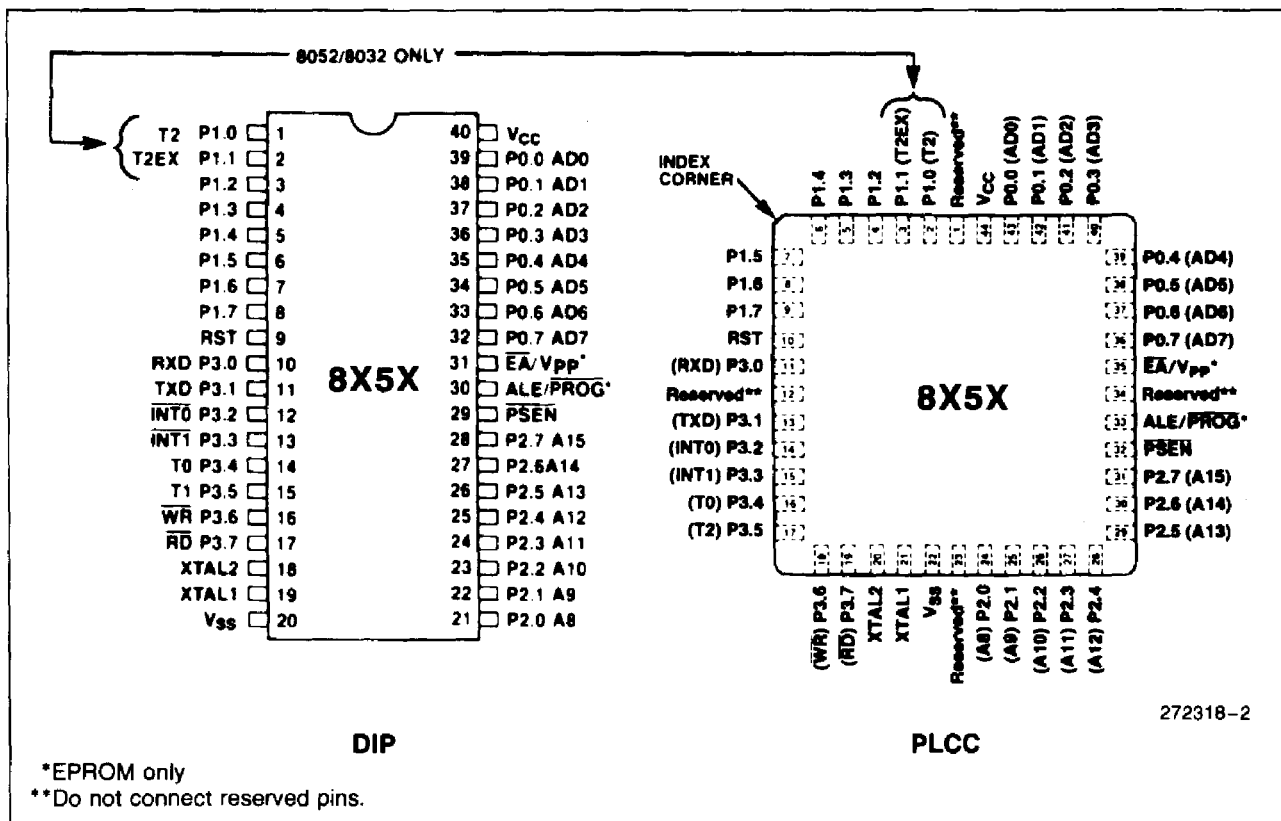

Figure 2. MCS® 51 Controller Connections

## PIN DESCRIPTIONS

**V<sub>CC</sub>**: Supply voltage.

**V<sub>SS</sub>**: Circuit ground.

**Port 0:** Port 0 is an 8-bit open drain bidirectional I/O port. As an output port each pin can sink 8 LS TTL inputs.

Port 0 pins that have 1's written to them float, and in that state can be used as high-impedance inputs.

Port 0 is also the multiplexed low-order address and data bus during accesses to external Program and Data Memory. In this application it uses strong internal pullups when emitting 1's and can source and sink 8 LS TTL inputs.

Port 0 also receives the code bytes during programming of the EPROM parts, and outputs the code bytes during program verification of the ROM and EPROM parts. External pullups are required during program verification.

**Port 1:** Port 1 is an 8-bit bidirectional I/O port with internal pullups. The Port 1 output buffers can sink/source 4 LS TTL inputs. Port 1 pins that have 1's written to them are pulled high by the internal pullups, and in that state can be used as inputs. As inputs, Port 1 pins that are externally pulled low will source current ( $I_{IL}$  on the data sheet) because of the internal pullups.

Port 1 also receives the low-order address bytes during programming of the EPROM parts and during program verification of the ROM and EPROM parts.

In the 8032AH, 8052AH and 8752BH, Port 1 pins P1.0 and P1.1 also serve the T2 and T2EX functions, respectively.

Port Pin	Alternative Function
P1.0 P1.1	T2 (Timer/Counter 2 External Input) T2EX (Timer/Counter 2 Capture/Reload Trigger)

**Port 2:** Port 2 is an 8-bit bidirectional I/O port with internal pullups. The Port 2 output buffers can sink/source 4 LS TTL inputs. Port 2 pins that have 1's written to them are pulled high by the internal pullups, and in that state can be used as inputs. As inputs, Port 2 pins that are externally pulled low will source current ( $I_{IL}$  on the data sheet) because of the internal pullups.

Port 2 emits the high-order address byte during fetches from external Program Memory and during accesses to external Data Memory that use 16-bit addresses (MOVX @DPTR). In this application it uses strong internal pullups when emitting 1's. During accesses to external Data Memory that use 8-bit addresses (MOVX @Ri), Port 2 emits the contents of the P2 Special Function Register.

Port 2 also receives the high-order address bits during programming of the EPROM parts and during program verification of the ROM and EPROM parts.

The protection feature of the 8051AHP causes bits P2.4 through P2.7 to be forced to 0, effectively limiting external Data and Code space to 4K each during external accesses.

**Port 3:** Port 3 is an 8-bit bidirectional I/O port with internal pullups. The Port 3 output buffers can sink/source 4 LS TTL inputs. Port 3 pins that have 1's written to them are pulled high by the internal pullups, and in that state can be used as inputs. As inputs, Port 3 pins that are externally pulled low will source current ( $I_{IL}$  on the data sheet) because of the pullups.

Port 3 also serves the functions of various special features of the MCS 51 Family, as listed below:

Port Pin	Alternative Function
P3.0	RXD (serial input port)
P3.1	TXD (serial output port)
P3.2	$\overline{INT0}$ (external interrupt 0)
P3.3	$\overline{INT1}$ (external interrupt 1)
P3.4	T0 (Timer 0 external input)
P3.5	T1 (Timer 1 external input)
P3.6	$\overline{WR}$ (external data memory write strobe)
P3.7	$\overline{RD}$ (external data memory read strobe)

**RST:** Reset input. A high on this pin for two machine cycles while the oscillator is running resets the device.

**ALE/PROG:** Address Latch Enable output pulse for latching the low byte of the address during accesses to external memory. This pin is also the program pulse input (PROG) during programming of the EPROM parts.

In normal operation ALE is emitted at a constant rate of  $\frac{1}{6}$  the oscillator frequency, and may be used for external timing or clocking purposes. Note, however, that one ALE pulse is skipped during each access to external Data Memory.

**PSEN:** Program Store Enable is the read strobe to external Program Memory.

When the device is executing code from external Program Memory, PSEN is activated twice each machine cycle, except that two PSEN activations are skipped during each access to external Data Memory.

**EA/Vpp:** External Access enable EA must be strapped to VSS in order to enable any MCS 51 device to fetch code from external Program memory locations starting at 0000H up to FFFFH. EA must be strapped to VCC for internal program execution.

Note, however, that if the Security Bit in the EPROM devices is programmed, the device will not fetch code from any location in external Program Memory.

This pin also receives the programming supply voltage (VPP) during programming of the EPROM parts.

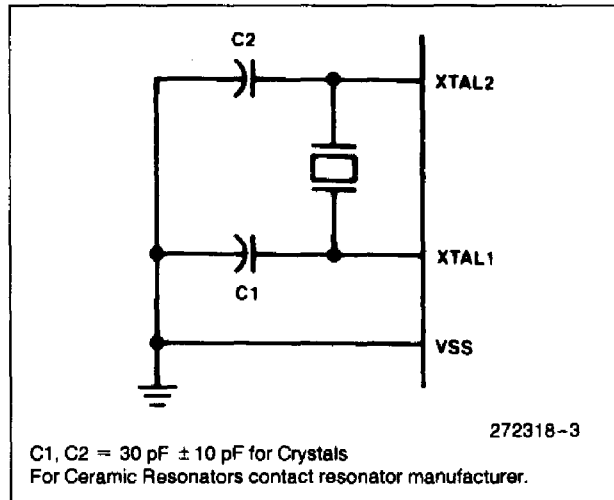

Figure 3. Oscillator Connections

**XTAL1:** Input to the inverting oscillator amplifier.

**XTAL2:** Output from the inverting oscillator amplifier.

### OSCILLATOR CHARACTERISTICS

XTAL1 and XTAL2 are the input and output, respectively, of an inverting amplifier which can be configured for use as an on-chip oscillator, as shown in Figure 3. Either a quartz crystal or ceramic resonator may be used. More detailed information concerning the use of the on-chip oscillator is available in Application Note AP-155, "Oscillators for Microcontrollers," Order No. 230659.

To drive the device from an external clock source, XTAL1 should be grounded, while XTAL2 is driven, as shown in Figure 4. There are no requirements on the duty cycle of the external clock signal, since the input to the internal clocking circuitry is through a divide-by-two flip-flop, but minimum and maximum high and low times specified on the data sheet must be observed.

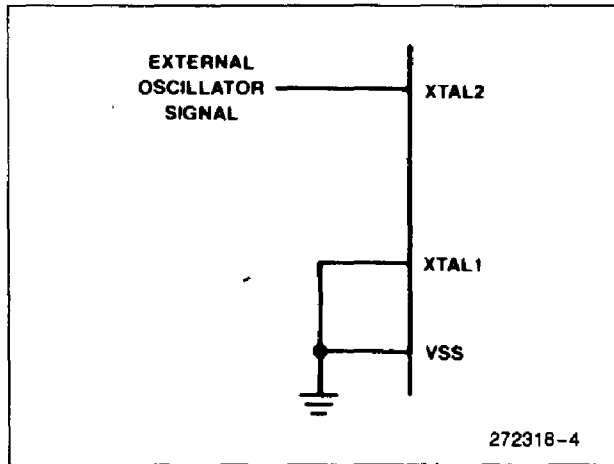

Figure 4. External Drive Configuration

### EXPRESS Version

The Intel EXPRESS system offers enhancements to the operational specifications of the MCS 51 family of microcontrollers. These EXPRESS products are designed to meet the needs of those applications whose operating requirements exceed commercial standards.

The EXPRESS program includes the commercial standard temperature range with burn-in, and an extended temperature range with or without burn-in.

With the commercial standard temperature range, operational characteristics are guaranteed over the temperature range of 0°C to +70°C. With the extended temperature range option, operational characteristics are guaranteed over a range of -40°C to +85°C.

The optional burn-in is dynamic, for a minimum time of 160 hours at 125°C with VCC = 5.5V ± 0.25V, following guidelines in MIL-STD-883, Method 1015.

Package types and EXPRESS versions are identified by a one- or two-letter prefix to the part number. The prefixes are listed in Table 1.

For the extended temperature range option, this data sheet specifies the parameters which deviate from their commercial temperature range limits.

2

Table 1. EXPRESS Prefix Identification

Prefix	Package Type	Temperature Range	Burn-In
P	Plastic	Commercial	No
D	Cerdip	Commercial	No
N	PLCC	Commercial	No
TD	Cerdip	Extended	No
TP	Plastic	Extended	No
TN	PLCC	Extended	No
QP	Plastic	Commercial	Yes
QD	Cerdip	Commercial	Yes
LD	Cerdip	Extended	Yes
LP	Plastic	Extended	Yes

**NOTE:**

Contact distributor or local sales office to match EXPRESS prefix with proper device.

**DESIGN CONSIDERATIONS**

- If an 8751BH or 8752BH is replacing an 8751H in a future design, the user should carefully compare both data sheets for DC or AC Characteristic differences. Note that the  $V_{IH}$  and  $I_{IH}$  specifications for the EA pin differ significantly between the devices.
- Exposure to light when the EPROM device is in operation may cause logic errors. For this reason, it is suggested that an opaque label be placed over the window when the die is exposed to ambient light.

- The 8051AHP cannot access external Program or Data memory above 4K. This means that the following instructions that use the Data Pointer only read/write data at address locations below 0FFFH:

```
MOVX A, @DPTR
MOVX @DPTR, A
```

When the Data Pointer contains an address above the 4K limit, those locations will not be accessed.

To access Data Memory above 4K, the MOVX @Ri,A or MOVX A,@Ri instructions must be used.



**ABSOLUTE MAXIMUM RATINGS\***

Ambient Temperature Under Bias . . . -40°C to +85°C  
 Storage Temperature . . . . . -65°C to +150°C  
 Voltage on  $\overline{EA}/V_{PP}$  Pin to  $V_{SS}$   
     8751H . . . . . -0.5V to +21.5V  
     8751BH/8752BH . . . . . -0.5V to +13.0V  
 Voltage on Any Other Pin to  $V_{SS}$  . . . . -0.5V to +7V  
 Power Dissipation . . . . . 1.5W

NOTICE: This is a production data sheet. It is valid for the devices indicated in the revision history. The specifications are subject to change without notice.

*\*WARNING: Stressing the device beyond the "Absolute Maximum Ratings" may cause permanent damage. These are stress ratings only. Operation beyond the "Operating Conditions" is not recommended and extended exposure beyond the "Operating Conditions" may affect device reliability.*

**OPERATING CONDITIONS**

Symbol	Description	Min	Max	Units
$T_A$	Ambient Temperature Under Bias Commercial Express	0	+70	°C
		-40	+85	°C
$V_{CC}$	Supply Voltage	4.5	5.5	V
$F_{OSC}$	Oscillator Frequency	3.5	12	MHz

**DC CHARACTERISTICS** (Over Operating Conditions)

All parameter values apply to all devices unless otherwise indicated

Symbol	Parameter	Min	Max	Units	Test Conditions
$V_{IL}$	Input Low Voltage (Except $\overline{EA}$ Pin of 8751H and 8751H-8)	-0.5	0.8	V	
$V_{IL1}$	Input Low Voltage to $\overline{EA}$ Pin of 8751H and 8751H-8	0	0.7	V	
$V_{IH}$	Input High Voltage (Except XTAL2, RST)	2.0	$V_{CC} + 0.5$	V	
$V_{IH1}$	Input High Voltage to XTAL2, RST	2.5	$V_{CC} + 0.5$	V	XTAL1 = $V_{SS}$
$V_{IH2}$	Input High Voltage to $\overline{EA}$ pin of 8751BH and 8752BH	4.5	5.5V		
$V_{OL}$	Output Low Voltage (Ports 1, 2, 3)*		0.45	V	$I_{OL} = 1.6$ mA
$V_{OL1}$	Output Low Voltage (Port 0, ALE, $\overline{PSEN}$ )* 8751H, 8751H-8  All Others		0.60	V	$I_{OL} = 3.2$ mA
			0.45	V	$I_{OL} = 2.4$ mA
			0.45	V	$I_{OL} = 3.2$ mA
$V_{OH}$	Output High Voltage (Ports 1, 2, 3, ALE, $\overline{PSEN}$ )	2.4		V	$I_{OH} = -80$ $\mu$ A
$V_{OH1}$	Output High Voltage (Port 0 in External Bus Mode)	2.4		V	$I_{OH} = -400$ $\mu$ A
$I_{IL}$	Logical 0 Input Current (Ports 1, 2, 3, and RST)		-500	$\mu$ A	$V_{IN} = 0.45$ V
$I_{IL1}$	Logical 0 Input Current ( $\overline{EA}$ ) 8751H and 8751H-8 8751BH 8752BH		-15	mA	$V_{IN} = 0.45$ V
			-10	mA	$V_{IN} = V_{SS}$
		-10		mA	$V_{IN} = V_{SS}$
			0.5	mA	

**DC CHARACTERISTICS** (Over Operating Conditions)

All parameter values apply to all devices unless otherwise indicated (Continued)

Symbol	Parameter	Min	Max	Units	Test Conditions
$I_{IL2}$	Logical 0 Input Current (XTAL2)		-3.2	mA	$V_{IN} = 0.45V$
$I_{LI}$	Input Leakage Current (Port 0) 8751H and 8751H-8 All Others		$\pm 100$ $\pm 10$	$\mu A$ $\mu A$	$0.45 \leq V_{IN} \leq V_{CC}$ $0.45 \leq V_{IN} \leq V_{CC}$
$I_{IH}$	Logical 1 Input Current ( $\overline{EA}$ ) 8751H and 8751H-8 8751BH/8752BH		500 1	$\mu A$ mA	$V_{IN} = 2.4V$ $4.5V < V_{IN} < 5.5V$
$I_{IH1}$	Input Current to RST to Activate Reset		500	$\mu A$	$V_{IN} < (V_{CC} - 1.5V)$
$I_{CC}$	Power Supply Current: 8031AH/8051AH/8051AHP 8032AH/8052AH/8751BH/8752BH 8751H/8751H-8		125 175 250	mA mA mA	All Outputs Disconnected; $\overline{EA} = V_{CC}$
$C_{IO}$	Pin Capacitance		10	pF	Test freq = 1 MHz

**NOTES:**

1. Capacitive loading on Ports 0 and 2 may cause spurious noise pulses to be superimposed on the  $V_{OLs}$  of ALE/ $\overline{PROG}$  and Ports 1 and 3. The noise is due to external bus capacitance discharging into the Port 0 and Port 2 pins when these pins make 1-to-0 transitions during bus operations. In the worst cases (capacitive loading > 100 pF), the noise pulse on the ALE/ $\overline{PROG}$  pin may exceed 0.8V. In such cases it may be desirable to qualify ALE with a Schmitt Trigger, or use an address latch with a Schmitt Trigger STROBE input.

2. ALE/ $\overline{PROG}$  refers to a pin on the 8751BH. ALE refers to a timing signal that is output on the ALE/ $\overline{PROG}$  pin.

3. Under steady state (non-transient) conditions,  $I_{OL}$  must be externally limited as follows:

Maximum  $I_{OL}$  per port pin: 10 mA

Maximum  $I_{OL}$  per 8-bit port -

Port 0: 26 mA

Ports 1, 2, and 3: 15 mA

Maximum total  $I_{OL}$  for all output pins: 71 mA

If  $I_{OL}$  exceeds the test condition,  $V_{OL}$  may exceed the related specification. Pins are not guaranteed to sink current greater than the listed test conditions.





**EXPLANATION OF THE AC SYMBOLS**

Each timing symbol has 5 characters. The first character is always a 'T' (stands for time). The other characters, depending on their positions, stand for the name of a signal or the logical status of that signal. The following is a list of all the characters and what they stand for.

- A: Address
- C: Clock
- D: Input Data
- H: Logic level HIGH
- I: Instruction (program memory contents)

- L: Logic level LOW, or ALE
- P: PSEN
- Q: Output data
- R: RD signal
- T: Time
- V: Valid
- W: WR signal
- X: No longer a valid logic level
- Z: Float

For example,

TAVLL = Time from Address Valid to ALE Low.  
 TLLPL = Time from ALE Low to PSEN Low.

**AC CHARACTERISTICS** (Under Operating Conditions; Load Capacitance for Port 0, ALE/ $\overline{\text{P}}\text{ROG}$ , and PSEN = 100 pF; Load Capacitance for All Other Outputs = 80 pF)

**2**
**EXTERNAL PROGRAM MEMORY CHARACTERISTICS**

Symbol	Parameter	12 MHz Oscillator		Variable Oscillator		Units
		Min	Max	Min	Max	
1/TCLCL	Oscillator Frequency			3.5	12.0	MHz
TLHLL	ALE Pulse Width	127		2TCLCL - 40		ns
TAVLL	Address Valid to ALE Low	43		TCLCL - 40		ns
TLLAX	Address Hold after ALE Low	48		TCLCL - 35		ns
TLLIV	ALE Low to Valid Instr In 8751H All Others		183		4TCLCL - 150	ns
			233		4TCLCL - 100	ns
TLLPL	ALE Low to PSEN Low	58		TCLCL - 25		ns
TPLPH	PSEN Pulse Width 8751H All Others	190		3TCLCL - 60		ns
		215		3TCLCL - 35		ns
TPLIV	PSEN Low to Valid Instr In 8751H All Others		100		3TCLCL - 150	ns
			125		3TCLCL - 125	ns
TPXIX	Input Instr Hold after PSEN	0		0		ns
TPXIZ	Input Instr Float after PSEN		63		TCLCL - 20	ns
TPXAV	PSEN to Address Valid	75		TCLCL - 8		ns
TAVIV	Address to Valid Instr In 8751H All Others		267		5TCLCL - 150	ns
			302		5TCLCL - 115	ns
TPLAZ	PSEN Low to Address Float		20		20	ns
TRLRH	RD Pulse Width	400		6TCLCL - 100		ns
TWLWH	WR Pulse Width	400		6TCLCL - 100		ns
TRLDV	RD Low to Valid Data In		252		5TCLCL - 165	ns
TRHDX	Data Hold after RD	0		0		ns
TRHDZ	Data Float after RD		97		2TCLCL - 70	ns
TLLDV	ALE Low to Valid Data In		517		8TCLCL - 150	ns
TAVDV	Address to Valid Data In		585		9TCLCL - 165	ns

**EXTERNAL PROGRAM MEMORY CHARACTERISTICS** (Continued)

Symbol	Parameter	12 MHz Oscillator		Variable Oscillator		Units
		Min	Max	Min	Max	
TLLWL	ALE Low to $\overline{RD}$ or $\overline{WR}$ Low	200	300	$3TCLCL - 50$	$3TCLCL + 50$	ns
TAVWL	Address to $\overline{RD}$ or $\overline{WR}$ Low	203		$4TCLCL - 130$		ns
TQVWX	Data Valid to $\overline{WR}$ Transition					
	8751H	13		$TCLCL - 70$		ns
	All Others	23		$TCLCL - 60$		ns
TQVWH	Data Valid to $\overline{WR}$ High	433		$7TCLCL - 150$		ns
TWHQX	Data Hold after $\overline{WR}$	33		$TCLCL - 50$		ns
TRLAZ	$\overline{RD}$ Low to Address Float		20		20	ns
TWHLH	$\overline{RD}$ or $\overline{WR}$ High to ALE High					
	8751H	33	133	$TCLCL - 50$	$TCLCL + 50$	ns
	All Others	43	123	$TCLCL - 40$	$TCLCL + 40$	ns

**NOTE:**

\*The 8751H-8 is identical to the 8751H but only operates up to 8 MHz. When calculating the AC Characteristics for the 8751H-8, use the 8751H formula for variable oscillators.

### EXTERNAL PROGRAM MEMORY READ CYCLE

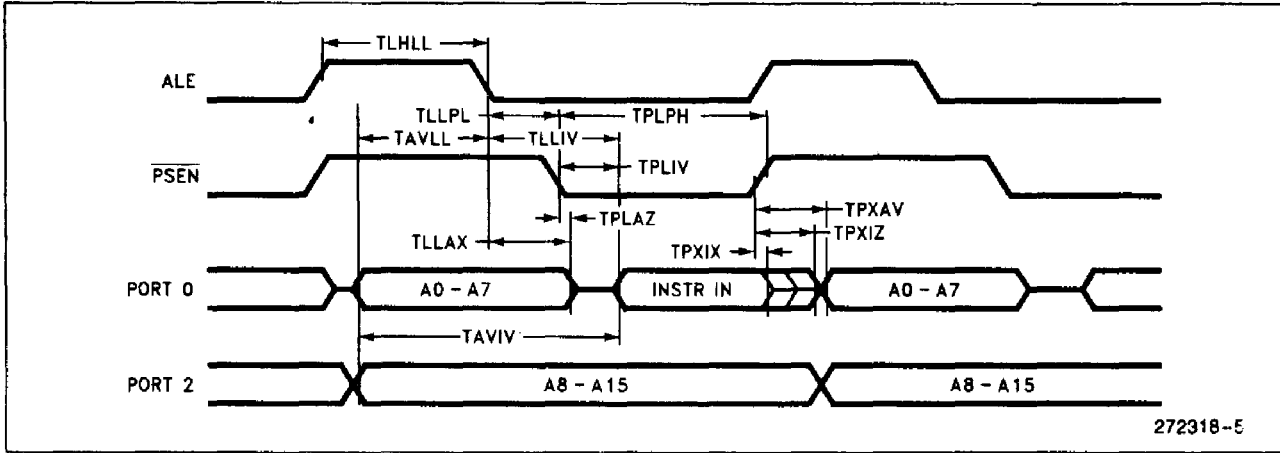

2

### EXTERNAL DATA MEMORY READ CYCLE

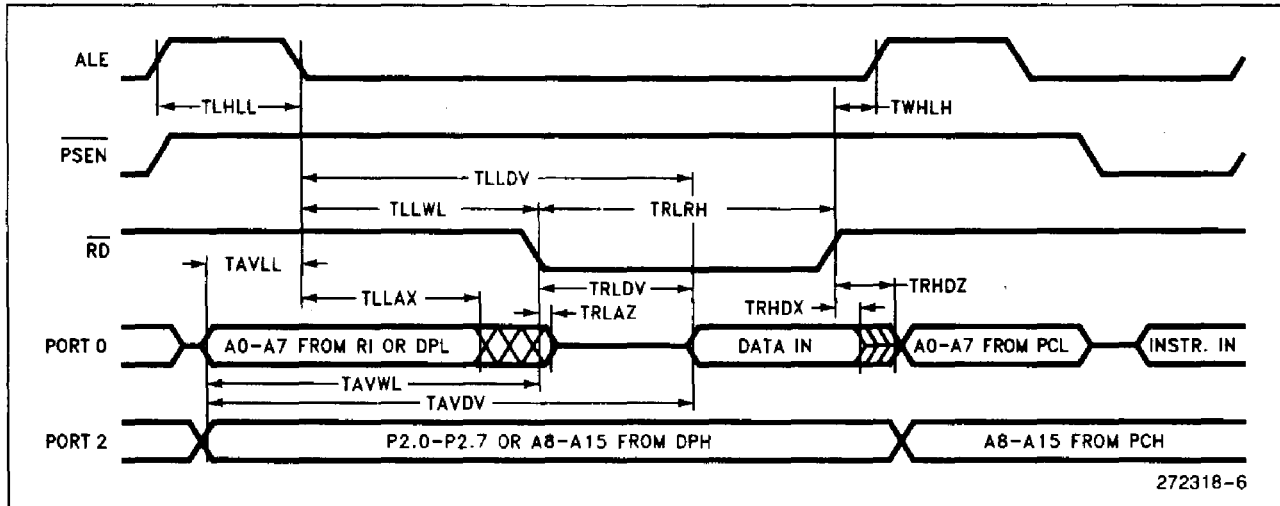

### EXTERNAL DATA MEMORY WRITE CYCLE

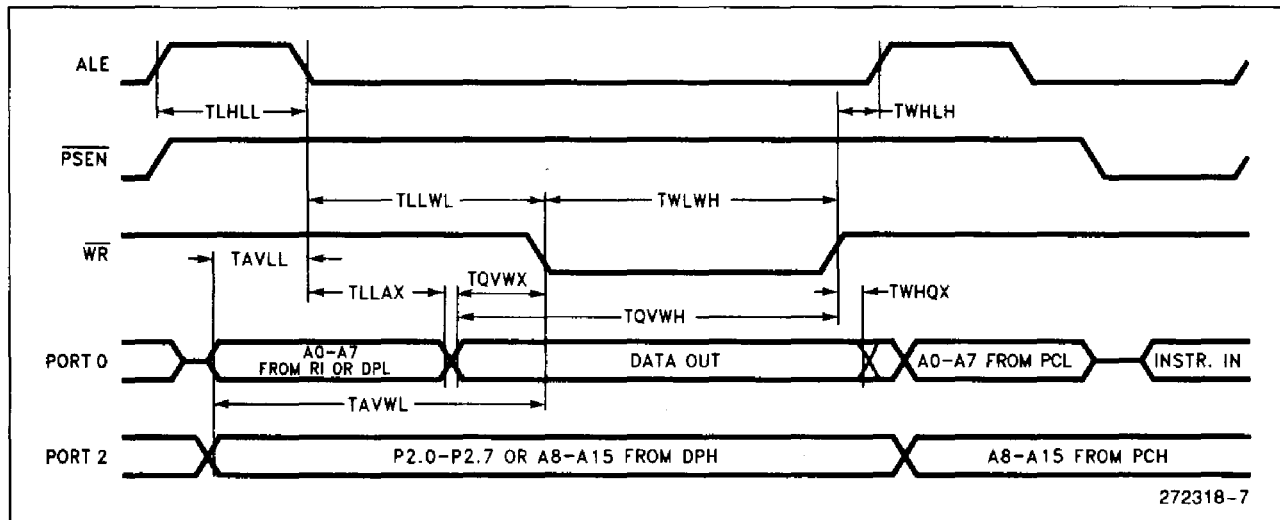

### SERIAL PORT TIMING—SHIFT REGISTER MODE

Test Conditions: Over Operating Conditions; Load Capacitance = 80 pF

Symbol	Parameter	12 MHz Oscillator		Variable Oscillator		Units
		Min	Max	Min	Max	
TXLXL	Serial Port Clock Cycle Time	1.0		12TCLCL		μs
TQVXH	Output Data Setup to Clock Rising Edge	700		10TCLCL - 133		ns
TXHQX	Output Data Hold after Clock Rising Edge	50		2TCLCL - 117		ns
TXHDX	Input Data Hold after Clock Rising Edge	0		0		ns
TXHDV	Clock Rising Edge to Input Data Valid		700		10TCLCL - 133	ns

### SHIFT REGISTER MODE TIMING WAVEFORMS

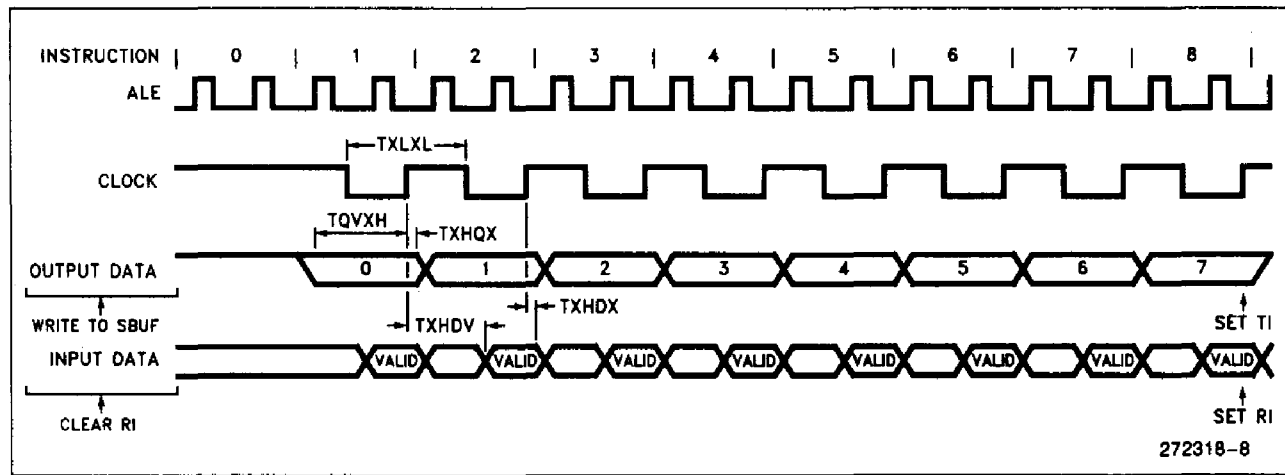

**EXTERNAL CLOCK DRIVE**

Symbol	Parameter	Min	Max	Units
1/TCLCL	Oscillator Frequency (except 8751H-8) 8751H-8	3.5 3.5	12 8	MHz MHz
TCHCX	High Time	20		ns
TCLCX	Low Time	20		ns
TCLCH	Rise Time		20	ns
TCHCL	Fall Time		20	ns

**EXTERNAL CLOCK DRIVE WAVEFORM**

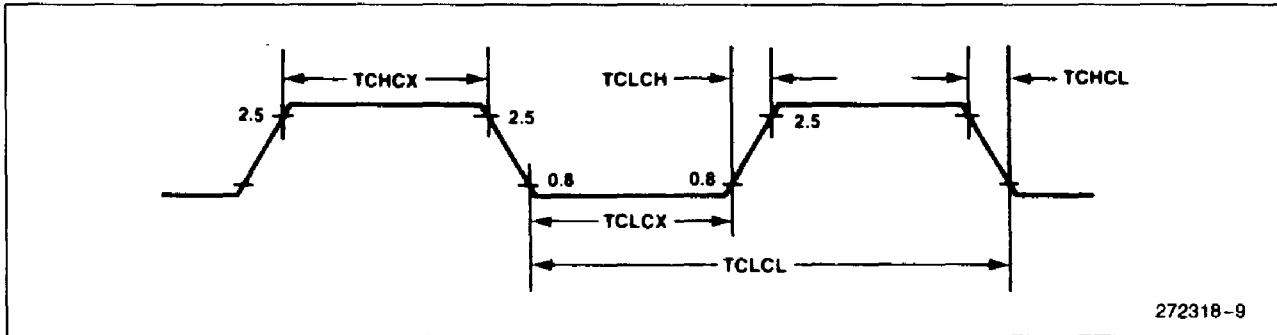

2

**AC TESTING INPUT, OUTPUT WAVEFORM**

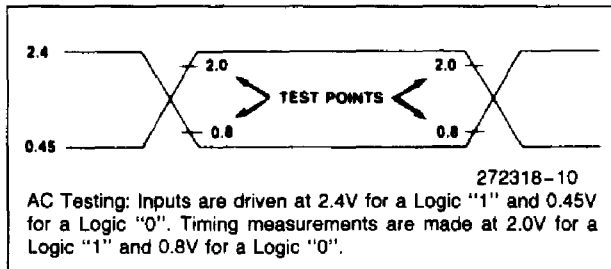

## EPROM CHARACTERISTICS

Table 3. EPROM Programming Modes

Mode	RST	PSEN	ALE	EA	P2.7	P2.6	P2.5	P2.4
Program	1	0	0*	VPP	1	0	X	X
Verify	1	0	1	1	0	0	X	X
Security Set	1	0	0*	VPP	1	1	X	X

**NOTE:**

"1" = logic high for that pin  
 "0" = logic low for that pin  
 "X" = "don't care"

"VPP" = +21V ±0.5V

\*ALE is pulsed low for 50 ms.

### PROGRAMMING THE 8751H

To be programmed, the part must be running with a 4 to 6 MHz oscillator. (The reason the oscillator needs to be running is that the internal bus is being used to transfer address and program data to appropriate internal registers.) The address of an EPROM location to be programmed is applied to Port 1 and pins P2.0–P2.3 of Port 2, while the code byte to be programmed into that location is applied to Port 0. The other Port 2 pins, and RST, PSEN, and EA/VPP should be held at the "Program" levels indicated in Table 3. ALE/PROG is pulsed low for 50 ms to program the code byte into the addressed EPROM location. The setup is shown in Figure 5.

Normally EA/VPP is held at a logic high until just before ALE/PROG is to be pulsed. Then EA/VPP is raised to +21V, ALE/PROG is pulsed, and then EA/VPP is returned to a logic high. Waveforms and detailed timing specifications are shown in later sections of this data sheet.

Note that the EA/VPP pin must not be allowed to go above the maximum specified VPP level of 21.5V for any amount of time. Even a narrow glitch above that voltage level can cause permanent damage to the device. The VPP source should be well regulated and free of glitches.

### Program Verification

If the Security Bit has not been programmed, the on-chip Program Memory can be read out for verification purposes, if desired, either during or after the programming operation. The address of the Program Memory location to be read is applied to Port 1 and pins P2.0–P2.3. The other pins should be held at the "Verify" levels indicated in Table 3. The contents of the addressed location will come out on Port 0. External pullups are required on Port 0 for this operation.

The setup, which is shown in Figure 6, is the same as for programming the EPROM except that pin P2.7 is held at a logic low, or may be used as an active-low read strobe.

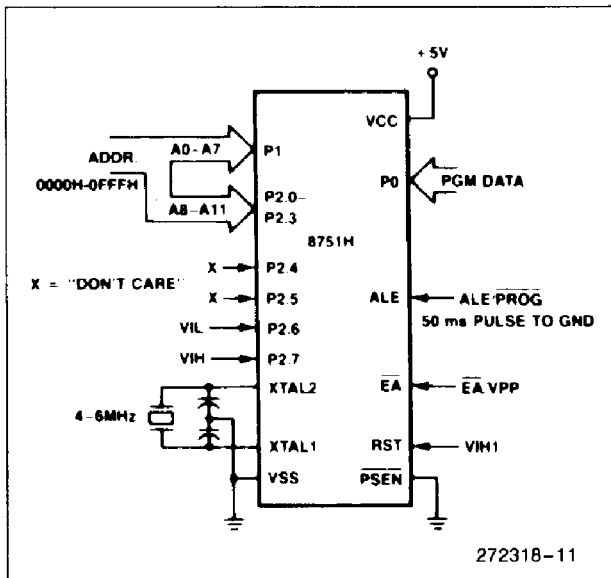

Figure 5. Programming Configuration

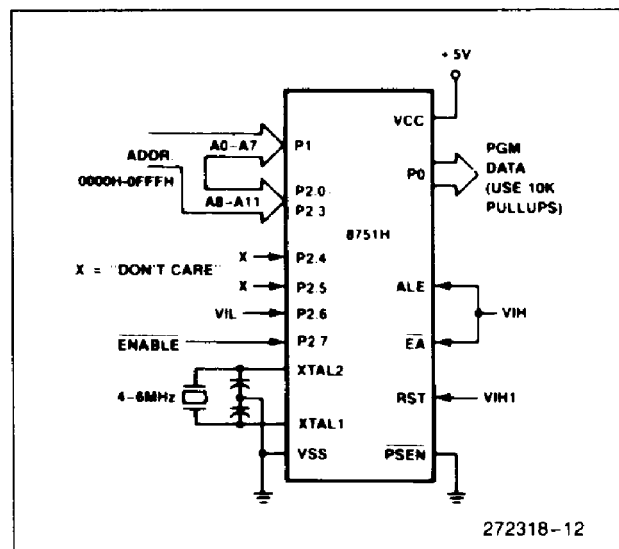

Figure 6. Program Verification

### EPROM Security

The security feature consists of a "locking" bit which when programmed denies electrical access by any external means to the on-chip Program Memory. The bit is programmed as shown in Figure 7. The setup and procedure are the same as for normal EPROM programming, except that P2.6 is held at a logic high. Port 0, Port 1 and pins P2.0–P2.3 may be in any state. The other pins should be held at the "Security" levels indicated in Table 3.

Once the Security Bit has been programmed, it can be cleared only by full erasure of the Program Memory. While it is programmed, the internal Program Memory can not be read out, the device can not be further programmed, and it **can not execute out of external program memory**. Erasing the EPROM, thus clearing the Security Bit, restores the device's full functionality. It can then be reprogrammed.

### Erase Characteristics

Erasure of the EPROM begins to occur when the device is exposed to light with wavelengths shorter than approximately 4,000 Angstroms. Since sunlight and fluorescent lighting have wavelengths in this range, exposure to these light sources over an extended time (about 1 week in sunlight, or 3 years in room-level fluorescent lighting) could cause inadvertent erasure. If an application subjects the device to this type of exposure, it is suggested that an opaque label be placed over the window.

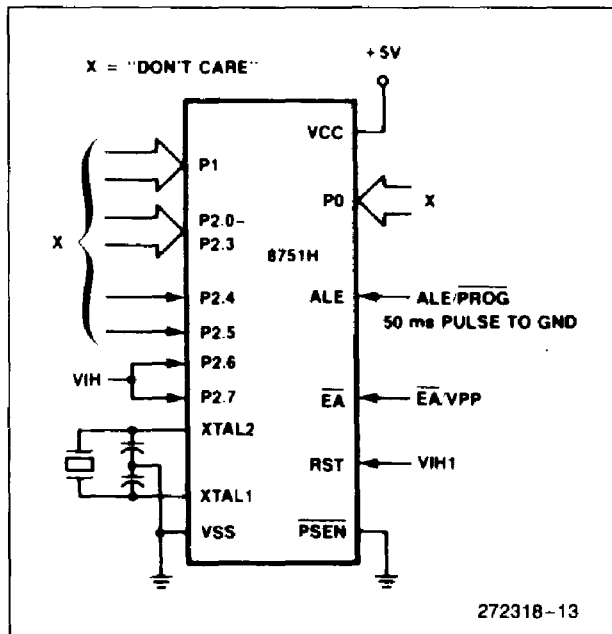

Figure 7. Programming the Security Bit

The recommended erasure procedure is exposure to ultraviolet light (at 2537 Angstroms) to an integrated dose of at least 15 W-sec/cm<sup>2</sup>. Exposing the EPROM to an ultraviolet lamp of 12,000 μW/cm<sup>2</sup> rating for 20 to 30 minutes, at a distance of about 1 inch, should be sufficient.

Erasure leaves the array in an all 1's state.

### EPROM PROGRAMMING AND VERIFICATION CHARACTERISTICS

T<sub>A</sub> = 21°C to 27°C; VCC = 5V ±10%; VSS = 0V

Symbol	Parameter	Min	Max	Units
VPP	Programming Supply Voltage	20.5	21.5	V
IPP	Programming Supply Current		30	mA
1/TCLCL	Oscillator Frequency	4	6	MHz
TAVGL	Address Setup to $\overline{\text{PROG}}$ Low	48TCLCL		
TGHAX	Address Hold after $\overline{\text{PROG}}$	48TCLCL		
TDVGL	Data Setup to $\overline{\text{PROG}}$ Low	48TCLCL		
TGHDX	Data Hold after $\overline{\text{PROG}}$	48TCLCL		
TEHSH	P2.7 ( $\overline{\text{ENABLE}}$ ) High to VPP	48TCLCL		
TSHGL	VPP Setup to $\overline{\text{PROG}}$ Low	10		μs
TGHSL	VPP Hold after $\overline{\text{PROG}}$	10		μs
TGLGH	$\overline{\text{PROG}}$ Width	45	55	ms
TAVQV	Address to Data Valid		48TCLCL	
TELQV	$\overline{\text{ENABLE}}$ Low to Data Valid		48TCLCL	
TEHQZ	Data Float after $\overline{\text{ENABLE}}$	0	48TCLCL	

2

EPROM PROGRAMMING AND VERIFICATION WAVEFORMS

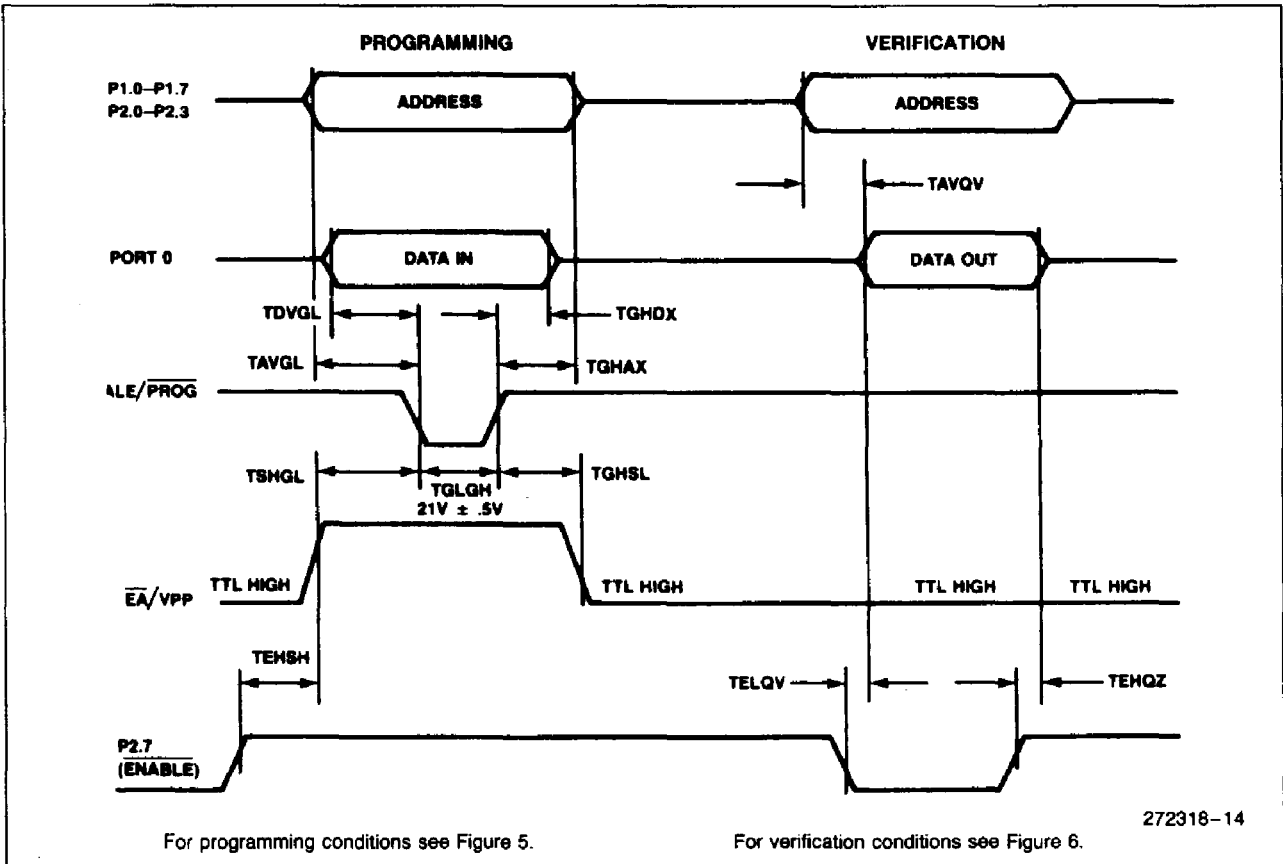



### Programming the 8751BH/8752BH

To be programmed, the 875XBH must be running with a 4 to 6 MHz oscillator. (The reason the oscillator needs to be running is that the internal bus is being used to transfer address and program data to appropriate internal registers.) The address of an EPROM location to be programmed is applied to Port 1 and pins P2.0 - P2.4 of Port 2, while the code byte to be programmed into that location is applied to Port 0. The other Port 2 and 3 pins, and RST, PSEN, and EA/V<sub>PP</sub> should be held at the "Program" levels indicated in Table 1. ALE/PROG is pulsed low to program the code byte into the addressed EPROM location. The setup is shown in Figure 8.

Normally EA/V<sub>PP</sub> is held at a logic high until just before ALE/PROG is to be pulsed. Then EA/V<sub>PP</sub> is raised to V<sub>PP</sub>, ALE/PROG is pulsed low, and then EA/V<sub>PP</sub> is returned to a valid high voltage. The voltage on the EA/V<sub>PP</sub> pin must be at the valid EA/V<sub>PP</sub> high level before a verify is attempted. Waveforms and detailed timing specifications are shown in later sections of this data sheet.

Note that the EA/V<sub>PP</sub> pin must not be allowed to go above the maximum specified V<sub>PP</sub> level for any amount of time. Even a narrow glitch above that voltage level can cause permanent damage to the device. The V<sub>PP</sub> source should be well regulated and free of glitches.

2

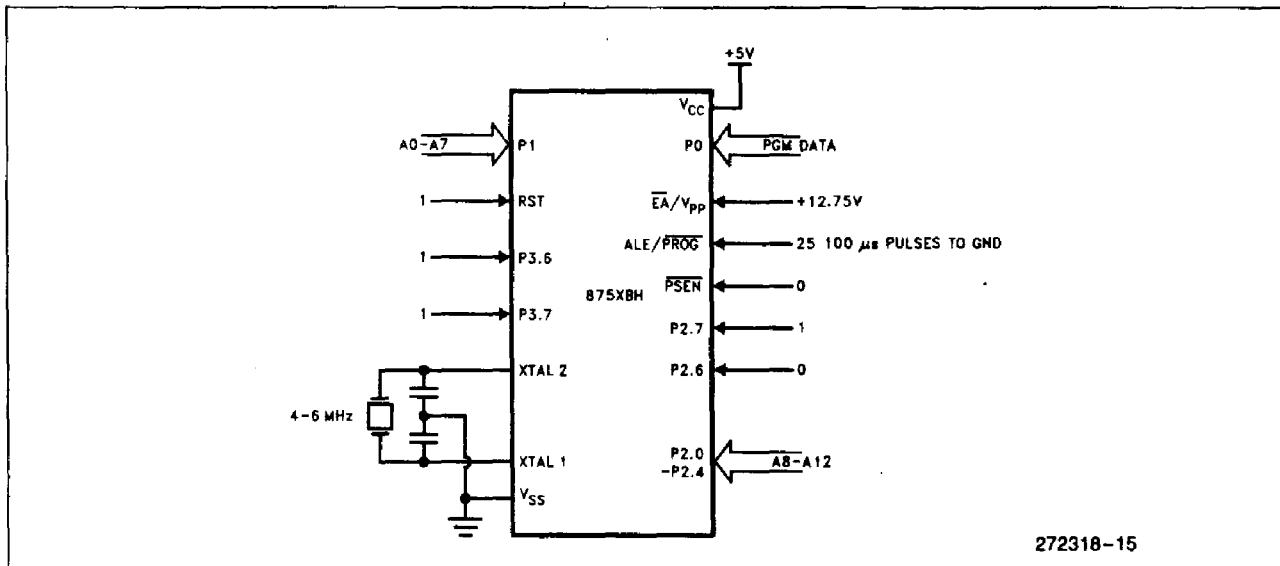

Figure 8. Programming the EPROM

Table 4. EPROM Programming Modes for 875XBH

MODE	RST	PSEN	ALE/ PROG	EA/ V <sub>PP</sub>	P2.7	P2.6	P3.6	P3.7
Program Code Data	1	0	0*	V <sub>PP</sub>	1	0	1	1
Verify Code Data	1	0	1	1	0	0	1	1
Program Encryption Table Use Addresses 0-1FH	1	0	0*	V <sub>PP</sub>	1	0	0	1
Program Lock    x = 1	1	0	0*	V <sub>PP</sub>	1	1	1	1
Bits (LBx)        x = 2	1	0	0*	V <sub>PP</sub>	1	1	0	0
Read Signature	1	0	1	1	0	0	0	0

**NOTES:**

"1" = Valid high for that pin

"0" = Valid low for that pin

"V<sub>PP</sub>" = +12.75V ±0.25V

\*ALE/PROG is pulsed low for 100 uS for programming. (Quick-Pulse Programming)

### QUICK-PULSE PROGRAMMING ALGORITHM

The 875XBH can be programmed using the Quick-Pulse Programming Algorithm for microcontrollers. The features of the new programming method are a lower  $V_{PP}$  (12.75 volts as compared to 21 volts) and a shorter programming pulse. For example, it is possible to program the entire 8 Kbytes of 875XBH EPROM memory in less than 25 seconds with this algorithm!

To program the part using the new algorithm,  $V_{PP}$  must be 12.75  $\pm$  0.25 Volts. ALE/PROG is pulsed low for 100  $\mu$ seconds, 25 times as shown in Figure 9. Then, the byte just programmed may be verified. After programming, the entire array should be verified. The Program Lock features are programmed using the same method, but with the setup as shown in Table 4. The only difference in programming Lock features is that the Lock features cannot be directly verified. Instead, verification of programming is by observing that their features are enabled.

### PROGRAM VERIFICATION

If the Lock Bits have not been programmed, the on-chip Program Memory can be read out for verification purposes, if desired, either during or after the programming operation. The address of the Program Memory location to be read is applied to Port 1 and pins P2.0 - P2.4. The other pins should be held at the "Verify" levels indicated in Table 1. The contents of the addressed location will come out on Port 0. External pullups are required on Port 0 for this operation. (If the Encryption Array in the EPROM has been programmed, the data present at Port 0 will be Code Data XNOR Encryption Data. The user must know the Encryption Array contents to manually "unencrypt" the data during verify.)

The setup, which is shown in Figure 10, is the same as for programming the EPROM except that pin P2.7 is held at a logic low, or may be used as an active low read strobe.

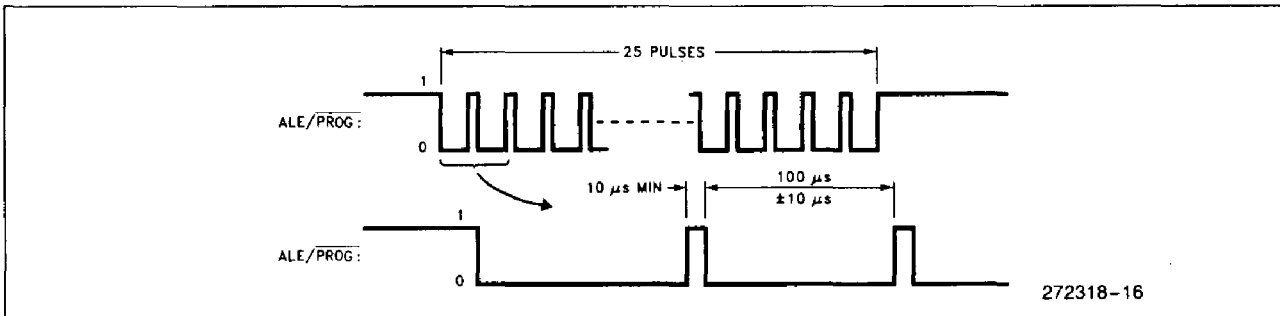

Figure 9. PROG Waveforms

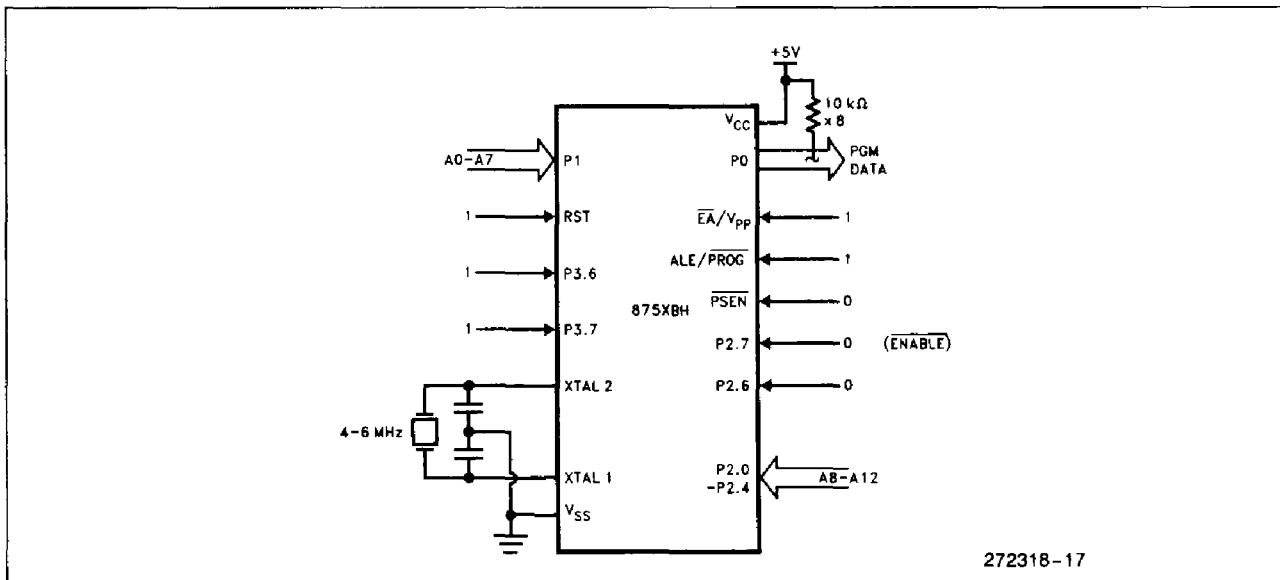

Figure 10. Verifying the EPROM



## PROGRAM MEMORY LOCK

The two-level Program Lock system consists of 2 Lock bits and a 32-byte Encryption Array which are used to protect the program memory against software piracy.

## ENCRYPTION ARRAY

Within the EPROM array are 32 bytes of Encryption Array that are initially unprogrammed (all 1s). Every time that a byte is addressed during a verify, 5 address lines are used to select a byte of the Encryption Array. This byte is then exclusive-NORed (XNOR) with the code byte, creating an Encrypted Verify byte. The algorithm, with the array in the unprogrammed state (all 1s), will return the code in its original, unmodified form.

It is recommended that whenever the Encryption Array is used, at least one of the Lock Bits be programmed as well.

## LOCK BITS

Also included in the EPROM Program Lock scheme are two Lock Bits which function as shown in Table 5.

Erasing the EPROM also erases the Encryption Array and the Lock Bits, returning the part to full unlocked functionality.

To ensure proper functionality of the chip, the internally latched value of the  $\overline{EA}$  pin must agree with its external state.

Table 5. Lock Bits and their Features

Lock Bits		Logic Enabled
LB1	LB2	
U	U	Minimum Program Lock features enabled. (Code Verify will still be encrypted by the Encryption Array)
P	U	MOVC instructions executed from external program memory are disabled from fetching code bytes from internal memory, $\overline{EA}$ is sampled and latched on reset, and further programming of the EPROM is disabled
P	P	Same as above, but Verify is also disabled
U	P	Reserved for Future Definition

P = Programmed  
U = Unprogrammed



## READING THE SIGNATURE BYTES

The signature bytes are read by the same procedure as a normal verification of locations 030H and 031H, except that P3.6 and P3.7 need to be pulled to a logic low. The values returned are:

- (030H) = 89H indicates manufactured by Intel
- (031H) = 51H indicates 8751BH
- 52H indicates 8752BH

### ERASURE CHARACTERISTICS

Erasure of the EPROM begins to occur when the 8752BH is exposed to light with wavelengths shorter than approximately 4,000 Angstroms. Since sunlight and fluorescent lighting have wavelengths in this range, exposure to these light sources over an extended time (about 1 week in sunlight, or 3 years in room-level fluorescent lighting) could cause inadvertent erasure. If an application subjects the device to

this type of exposure, it is suggested that an opaque label be placed over the window.

The recommended erasure procedure is exposure to ultraviolet light (at 2537 Angstroms) to an integrated dose of at least 15 W-sec/cm. Exposing the EPROM to an ultraviolet lamp of 12,000  $\mu\text{W}/\text{cm}$  rating for 30 minutes, at a distance of about 1 inch, should be sufficient.

Erasure leaves the array in an all 1s state.

### EPROM PROGRAMMING AND VERIFICATION CHARACTERISTICS

( $T_A = 21^\circ\text{C}$  to  $27^\circ\text{C}$ ,  $V_{CC} = 5.0\text{V} \pm 10\%$ ,  $V_{SS} = 0\text{V}$ )

Symbol	Parameter	Min	Max	Units
$V_{PP}$	Programming Supply Voltage	12.5	13.0	V
$I_{PP}$	Programming Supply Current		50	mA
1/TCLCL	Oscillator Frequency	4	6	MHz
TAVGL	Address Setup to $\overline{\text{PROG}}$ Low	48TCLCL		
TGHAX	Address Hold After $\overline{\text{PROG}}$	48TCLCL		
TDVGL	Data Setup to $\overline{\text{PROG}}$ Low	48TCLCL		
TGHDX	Data Hold After $\overline{\text{PROG}}$	48TCLCL		
TEHSH	P2.7 ( $\overline{\text{ENABLE}}$ ) High to $V_{PP}$	48TCLCL		
TSHGL	$V_{PP}$ Setup to $\overline{\text{PROG}}$ Low	10		$\mu\text{S}$
TGHSL	$V_{PP}$ Hold After $\overline{\text{PROG}}$	10		$\mu\text{S}$
TGLGH	$\overline{\text{PROG}}$ Width	90	110	$\mu\text{S}$
TAVQV	Address to Data Valid		48TCLCL	
TELQV	$\overline{\text{ENABLE}}$ Low to Data Valid		48TCLCL	
TEHQZ	Data Float After $\overline{\text{ENABLE}}$	0	48TCLCL	
TGHGL	$\overline{\text{PROG}}$ High to $\overline{\text{PROG}}$ Low	10		$\mu\text{S}$

### EPROM PROGRAMMING AND VERIFICATION WAVEFORMS

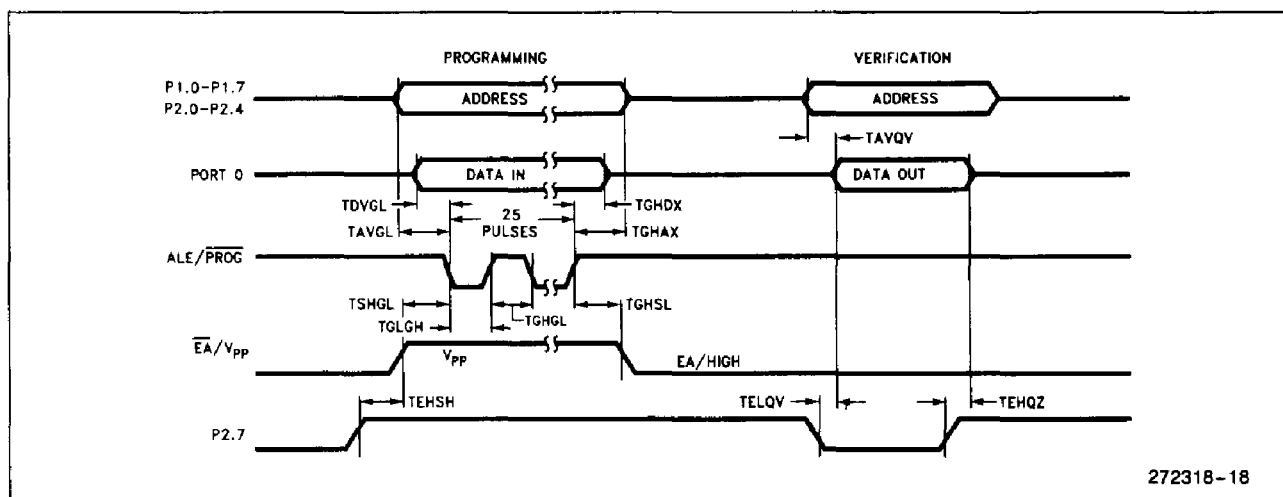

272318-18

**DATA SHEET REVISION HISTORY**

This datasheet (272318-001) replaces the following datasheets:

MCS® 51 Controllers (270048-007)

8051AHP (270279-004)

8751BH (270248-005)

8751BH EXPRESS (270708-001)

8752BH (270429-004)

8752BH EXPRESS (270650-002)