

- MATERIAL**
 CONTACTS: PHOSPHOR BRONZE
 HOUSING & PIN SPACER: UL 94V-0 RATED, THERMOPLASTIC, BLACK
 BRACKET: ZINC
 SHELL: CARBON STEEL
 BOARDLOCKS: COPPER ALLOY.
- FINISH**
 CONTACTS: EITHER 0.76µm [.000030] MIN GOLD PLATE FOR A LENGTH OF 0.64 [.025] MAX, 0.13 [.005] MIN FROM MATING END OR GOLD FLASH OVER PALLADIUM NICKEL PLATE, 0.76µm [.000030] MIN TOTAL FOR A LENGTH OF 0.64 [.025] MAX, 0.13 [.005] MIN FROM MATING END, 3.81µm [.000150] MIN TIN-LEAD ON OPPOSITE END FOR A LENGTH OF 2.72 [.107] MIN, BOTH OVER 1.27µm [.000050] MIN NICKEL.
 SHELL: 5.08µm [.000200] MIN NICKEL OVER 1.27µm [.000050] MIN COPPER.
 BRACKET: 2.54µm [.000100] MIN NICKEL OVER 5.08µm [.000200] COPPER.
- 5.08µm [.000200] MIN TIN-LEAD OVER 1.27µm [.000050] MIN NICKEL.
 3.00µm [.000118] MIN TIN OVER 1.27µm [.000050] MIN NICKEL.
 OBSOLETE PARTS: OBSOLETE CIS STREAMLINING PER D.RENAUD/D.SINISI

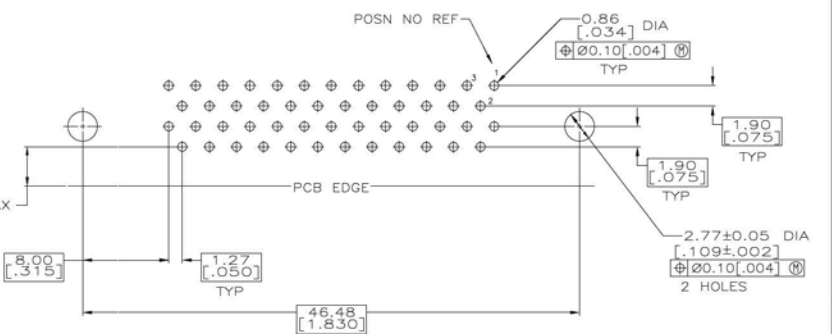

P.C. BOARD MOUNTING DIMENSIONS
 CONNCTOR SIDE
 P.C. BOARD THICKNESS 1.57±0.20 [.062±.008]
 PC BOARD PATTERN S

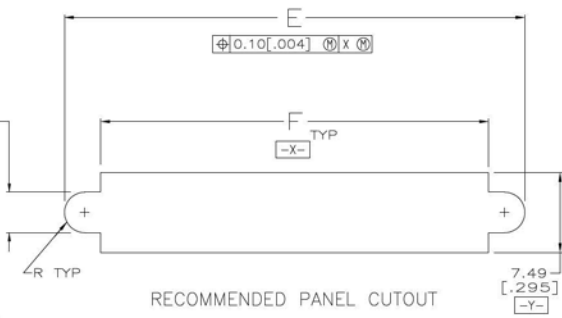
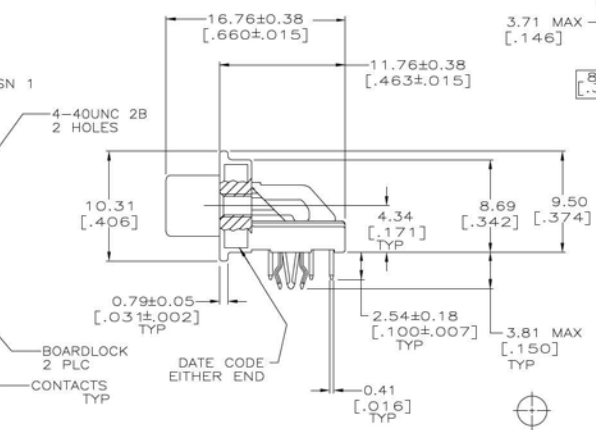
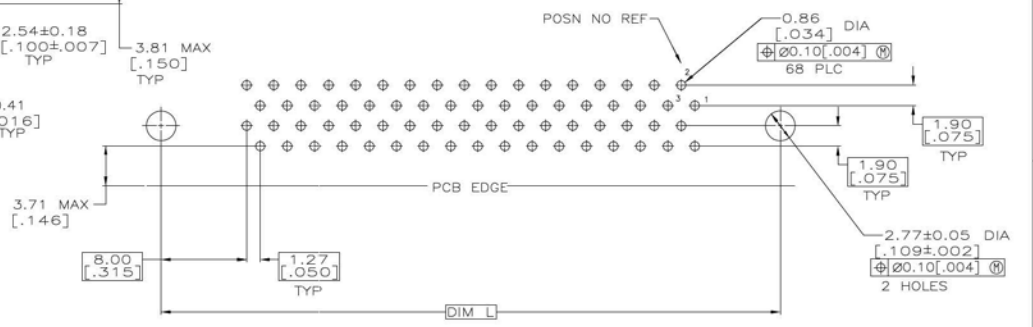

P.C. BOARD MOUNTING DIMENSIONS
 CONNCTOR SIDE
 P.C. BOARD THICKNESS 1.57±0.20 [.062±.008]
 PC BOARD PATTERN T

T	△	57.91 [2.280]	0.64 [.025]	49.12 [1.934]	61.72 [2.430]	63.88 [2.515]	46.13 [1.816]	57.91 [2.280]	68	△	1-787170-0
T	△	78.23 [3.080]	0.64 [.025]	69.44 [2.734]	82.04 [3.230]	84.20 [3.315]	66.45 [2.616]	78.23 [3.080]	100		787170-9
T	△	57.91 [2.280]	0.64 [.025]	49.12 [1.934]	61.72 [2.430]	63.88 [2.515]	46.13 [1.816]	57.91 [2.280]	68		787170-7
S	△	-	1.27 [.050]	37.69 [1.484]	50.29 [1.980]	52.45 [2.065]	34.70 [1.366]	46.48 [1.830]	50		787170-5
T	△	40.13 [1.580]	0.64 [.025]	36.78 [1.448]	43.56 [1.715]	46.10 [1.815]	28.35 [1.116]	40.13 [1.580]	40		787170-4
PC BOARD PATTERN	BOARDLOCK FINISH	L	G	F	E	D	B	A	NO OF POSN		PART NUMBER

THIS DRAWING IS A CONTROLLED DOCUMENT.

DRW: MCMMASTER
 DES: SHUEY
 APP: M. WALMSLEY
 PROD: 108-1228
 APPLICATION SPEC: 114-40029
 WEIGHT: -

DATE: 10/07/99
 DRAWING NO: 787170
 CUSTOMER DRAWING

Typo Electronics Corporation
 Harrisburg, PA 17105-3608

RECEPTACLE ASSEMBLY, SHIELDED, RIGHT ANGLE, .050 SERIES, AMPLIMITE

SCALE: 4:1 SHEET 1 OF 1 REV: V1