

NOTE

All numerical values are in metric units [with U.S. customary units in brackets]. Dimensions are in millimeters [and inches]. Unless otherwise specified, dimensions have a tolerance of ± 0.13 [$\pm .005$] and angles have a tolerance of $\pm 2^\circ$. Figures and illustrations are for identification only and are not drawn to scale.

1. INTRODUCTION

This specification covers the requirements for application of Terminal Block Stacking Connectors. The complete line consists of one-piece side entry, angled entry, and top entry printed circuit (pc) board terminal blocks and plug connectors with mating right-angle or vertical mount pc board headers. PC board headers are offered with either open and closed ends, and also in double-row configurations. These terminal blocks feature screw clamp contacts that accept wire sizes 0.03–4 mm² (solid), or 0.03–2.5 mm² (stranded). Wire entry is perpendicular to the screws. They are available in configurations of 2.54, 3.5, 3.81, 5, 5.08, 7.5, 7.62, 10, or 10.16 mm contact centerline spacings.

Side entry wire, angled entry wire, and top entry wire pc board mount terminal blocks (only 5, 5.08, 7.5, and 7.62 mm pitch), as well as the pc board mating header (only 5, 5.08 mm pitch, open-ended, or unshrouded) are stackable end-to-end without loss of centerline. Ease of assembly is facilitated, in most versions, by built-in interlocks on the housing.

When corresponding with Tyco Electronics Personnel, use the terminology provided on this specification to help facilitate your inquiry for information. Basic terms and features of components are provided in Figure 1.

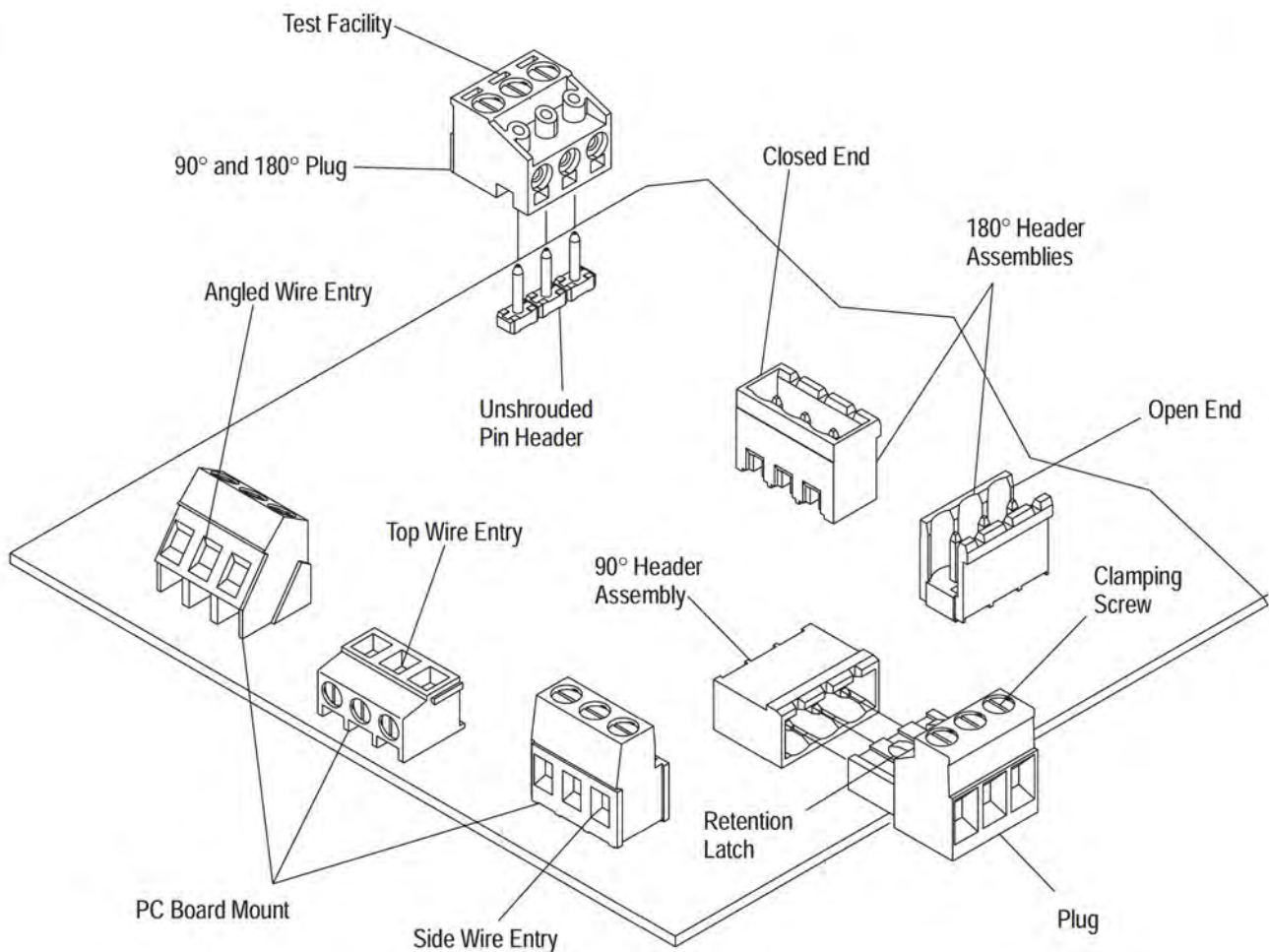

Figure 1 (cont'd)

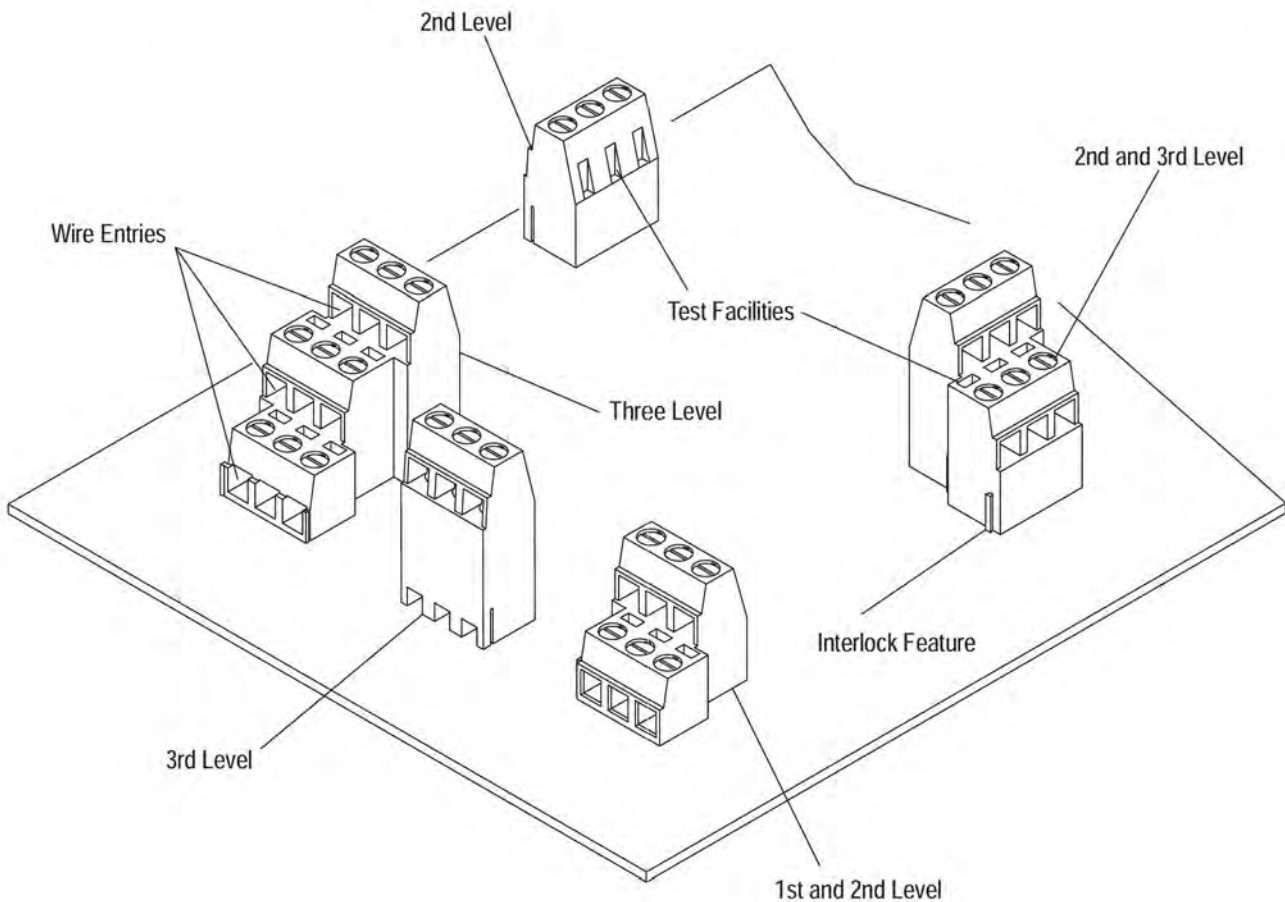

Figure 1 (end)

2. REFERENCE MATERIAL

2.1. Revision Summary

This paragraph is reserved for a revision summary covering the most recent additions and changes made to this specification which include the following:

Per EC 0990-0135-04

- Updated document to corporate requirements
- Changed soldering information in Paragraph 3.7.B and Figure 7
- Deleted text from Paragraph 3.7.C

2.2. Customer Assistance

Reference base part number 284093 and product code 7742 are representative numbers of Terminal Block Stacking Connectors. Use of these numbers will identify the product line and expedite your inquiries through a service network established to help you obtain product information. Such information can be obtained through a local Tyco Electronics Representative (Field Sales Engineer, Field Applications Engineer, etc) or, after purchase, by calling the Tooling Assistance Center or the FAX/Product Information Center number at the bottom of page 1.

2.3. Drawings

Customer Drawings for the connectors are available from the service network. The information contained in Customer Drawings takes priority if there is a conflict with this specification or with any technical documentation supplied by Tyco Electronics.

2.4. Specifications

Product Specification 108-20166 provides test and performance requirements.

2.5. Manuals

Manual 402-40 is available upon request and can be used as a guide in soldering. This manual provides information on various flux types and characteristics along with the commercial designation and flux removal procedures. A checklist is attached to the manual as a guide for information on soldering problems.

2.6. Instructional Material

Instruction Sheet 408-6927 provides information on design recommendations for pc board support fixtures.

3. REQUIREMENTS

3.1. Materials

Terminal Block Stacking Connectors are made of UL 94V-0 rated PA-66.

3.2. Storage

A. Ultraviolet Light

Prolonged exposure to ultraviolet light may deteriorate the chemical composition used in the pc board jack connector material.

B. Shelf Life

The jack connectors are packaged and shipped in protective anti-static tube or tray containers. To prevent damage to these connectors, they should remain in the container until ready for installation. Also, to prevent possible storage contamination, the connectors should be used on a first in, first out basis.

C. Chemical Exposure

Do not store jack connectors near any chemical listed below as they may cause stress corrosion cracks in the connector.

Alkalies	Ammonia	Citrates	Phosphates	Citrates	Sulfur Compounds
Amines	Carbonates	Nitrites	Sulfur	Nitrites	Tartrates

3.3. Polarization

Design configuration prevents plug and receptacle connectors from being mated incorrectly.

3.4. PC Board Layout

A. Single Connector

Use a pc board with a nominal thickness of 1.6-2.4 mm. See Figure 2. Customer drawings provide a complete definition of pc board layout.

DESCRIPTION	WIRE SIZE		HOLE DIAMETER (mm)
	SOLID	STRANDED	
PC Board Mount	1 mm ²	0.75 mm ²	1.1 +0.1/-0
	1.5 mm ²	1 mm ²	1.1 +0.1/-0
	2.5 mm ²	1.5 mm ²	1.4 +0.1/-0
	4 mm ²	2.5 mm ²	1.4 +0.1/-0
Pin Header Unshrouded	---	---	1.4 +0.1/-0
Header Assembly	---	---	1.4 +0.1/-0

Figure 2

B. Stacked Connectors

PC board mount connectors with 5, 5.08, 7.5, and 7.62 mm pitch; or headers with 5 and 5.08 mm pitch can be stacked end-to-end without loss of centerline spacing to create the required position size. Ease of assembly is facilitated in most versions by interlocking features. The 5 and 5.08 mm pitch open-ended headers are designed for stacking applications. However, those with closed ends are not. See Figure 3.

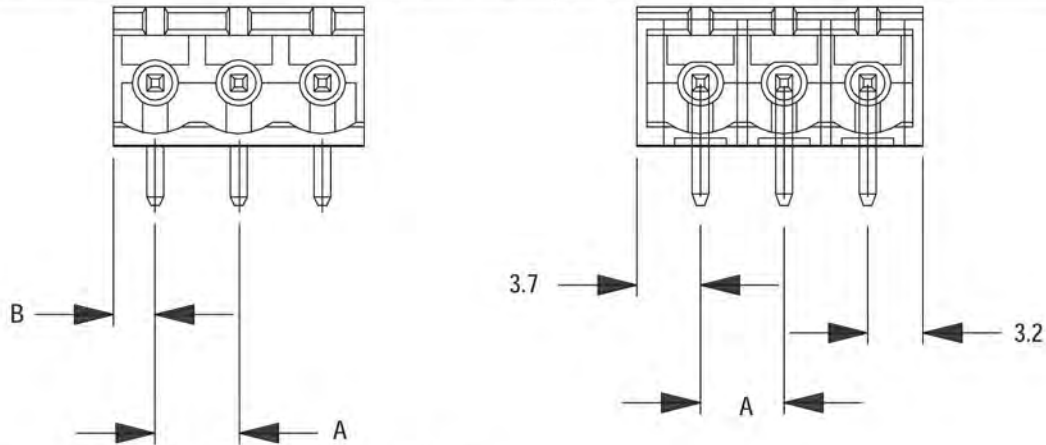

Dimension "A" equals contact centerline spacing (5 or 5.08).
Dimension "B" equals 1/2 dimension "A".
Value in parenthesis refers to 5.08 pitch headers

Figure 3

3.5. Wire Selection, Preparation, and Installation

A. Selection

The connectors will accept wires with conductors of the sizes defined in Figure 4.

B. Strip Length

The wire must be stripped to the proper dimension to ensure correct insertion depth in the connector. Excessive conductor will be exposed if the strip length is too long and entrapment of the insulation or improper termination will result if the strip length is too short. See Figure 4.

C. Installation

Two screwdrivers must be used to open and close the screw clamps. The wire must be inserted into the wire hole until the insulation is even with the housing at the wire hole opening. The screw must be hand tightened with the proper screwdriver to within the torque provided in Figure 4. Pull back on the wire to be sure it is secure and check there are no wire strands outside the terminal block.

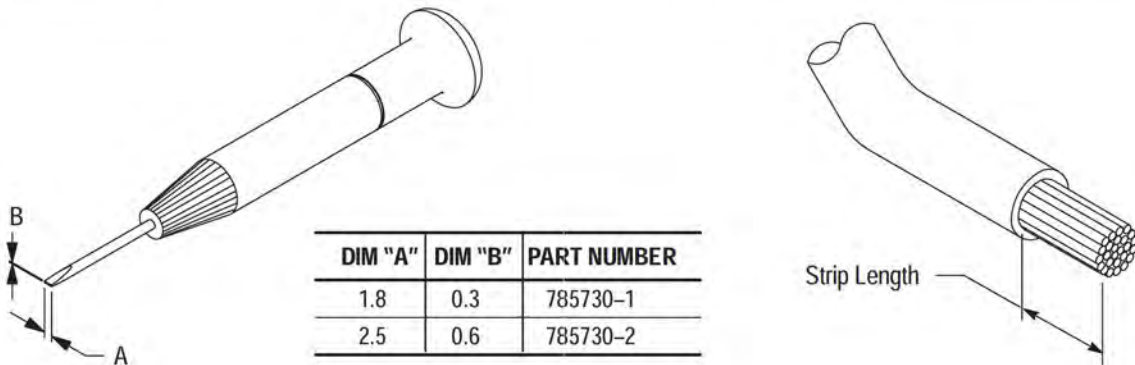

Figure 4 (cont'd)

DESCRIPTION	WIRE SIZE (mm ²)		STRIP LENGTH (mm)	SCREW TORQUE (Nm)	SCREWDRIVER
	SOLID	STRANDED			
PC Board Mount	1	0.75	4-5	0.20	785730-1
Plug (3.5-3.81 mm Pitch)	0.05-1.5		5-6	0.25	
PC Board Mount	1.5	1	5-6	0.5	785730-2
	2.5	1.5	5.5-6.5	0.5	
	4	2.5	6.5-7	0.5	
Plug (90° & 180°)	1.5	1	4-6	0.5	
Plug	2.5	1.5	6-7.5	0.5-0.8	

Figure 4 (end)

3.6. Physical Characteristics

The terminal block connectors consist of specially designed screw-activated mechanisms that are captivated inside the housing. When stripped wire is inserted into the connector and the screw is tightened, the screw activates a clamp which compresses the wire against the terminal. See Figure 5.

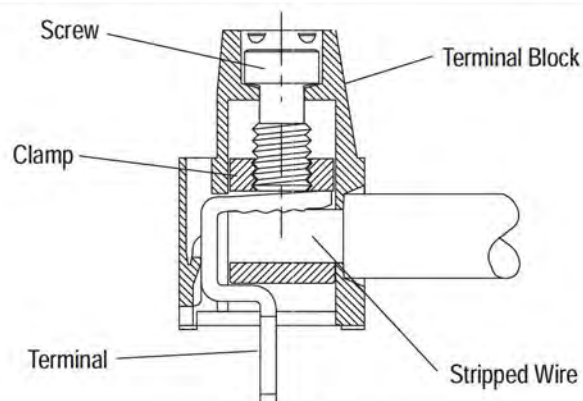

Figure 5

3.7. Soldering

NOTE

Manual 402-40 provides some guidelines for establishing soldering practices. Refer to Paragraph 2.5, Manuals.

A. Fluxing

The contact solder tails and, if applicable, attaching hardware must be fluxed prior to soldering with a mildly active, rosin base flux. Selection of the flux will depend on the type of pc board and other components mounted on the board. Additionally, the flux must be compatible with the wave solder line, manufacturing, health, and safety requirements. Call the Product Information number at the bottom of page 1 for consideration of other types of flux. Some fluxes that are compatible with these connectors are provided in Figure 6.

FLUX TYPE	ACTIVITY	RESIDUE	COMMERCIAL DESIGNATION	
			KESTER	ALPHA
Type RMA (Mildly Activated)	Mild	Noncorrosive	185/197	611
Center (Activated)	Medium	May be Corrosive	1544, 1545, 1547	711, 809, 811

Figure 6

B. Soldering Guidelines

Eurostyle Connectors can be soldered using wave or equivalent soldering techniques. Refer to Manual 402-40 for soldering guidelines. The temperatures and exposure time shall be as specified in Figure 7.

NOTE *SMT High Temperature Connectors that are compatible with typical surface mount soldering techniques are also available. They can withstand a maximum temperature of 260° C [500° F] for 1 minute maximum.*

SOLDERING PROCESS	TEMPERATURE●		TIME (At Max Temp)
	CELSIUS	FAHRENHEIT	
Wave Soldering	250°	482°	5 Seconds

●Wave Temperature (Under PC Board)

Figure 7

C. Reflow Parameters

Due to the many variables involved with the reflow process (ie, component density, orientation, etc), we recommend that the user conduct trial runs under actual manufacturing conditions to ensure product and process compatibility.

D. Cleaning

After soldering, removal of fluxes, residues, and activators is necessary. Consult with the supplier of the solder paste and flux for recommended cleaning solvents. The following is a listing of common cleaning solvents that will not affect the connectors. The connectors will be unaffected by any of these solvents for the time and temperatures listed in Figure 8.

Cleaners must be free of dissolved flux and other contaminants. We recommend cleaning with the pc board on its edge. If using an aqueous cleaner, we recommend standard equipment such as a soak-tank or an automatic in-line machine

CAUTION *Even when using "no clean" solder paste, it is imperative that the contact interface be kept clean of flux and residue, since it acts as an insulator. Flux may migrate under certain conditions with elevated temperatures and, therefore, cleaning is necessary even with "no clean" paste.*

CLEANER		TIME (Minutes)	TEMPERATURES (Maximum)	
NAME	TYPE		CELSIUS	FAHRENHEIT
ALPHA 2110	Aqueous	1	132	270
BIOACT EC-7	Solvent	5	100	212
Butyl CARBITOL	Solvent	1	Room Ambient	
Isopropyl Alcohol	Solvent	5	100	212
KESTER 5778	Aqueous	5	100	212
KESTER 5779	Aqueous	5	100	212
LONCOTERGE 520	Aqueous	5	100	212
LONCOTERGE 530	Aqueous	5	100	212
Terpene Solvent	Solvent	5	100	212

Figure 8

DANGER *Consideration must be given to toxicity and other safety requirements recommended by the solvent manufacturer. Trichloroethylene and Methylene Chloride can be used with no harmful affect to the connectors; however, Tyco Electronics does not recommend them because of the harmful occupational and environmental effects. Both are carcinogenic (cancer-causing) and Trichloroethylene is harmful to the earth's ozone layer.*

NOTE *If you have a particular solvent that is not listed, contact the Product Information number at the bottom of page 1.*

E. Drying

Air drying of cleaned connectors is recommended. Temperature for the connectors should not exceed -40 to 105°C [-40 to 221°F]. Degradation of the housings could result from extreme temperatures.

3.8. Repair

Damaged wires can be removed from screw clamp connectors and replaced. If a post in a header is damaged, it can not be repaired; the solder must be removed and the header must be replaced with a new one.

4. QUALIFICATIONS

Terminal Block Stacking Connectors are recognized by Underwriters Laboratories Inc. (UL) under File Number E66717 and certified to the Canadian Standards Association (CSA) under File LR7189. The Istituto Italiano del Marchio di Qualita (IMQ) certifies these products to IEC 998-1 and 998-2-1.

5. TOOLING

The only tooling required to attach the wire to these connectors is a flat-bladed screwdriver 785730-[]. Refer to Figure 4 for specific usage.

6. VISUAL AID

Figure 9 shows typical application of Terminal Block Stacking Connectors and calls out the conditions that production personnel should check to ensure a good installation. For dimensional inspection, refer to the details in the preceding pages of this specification.

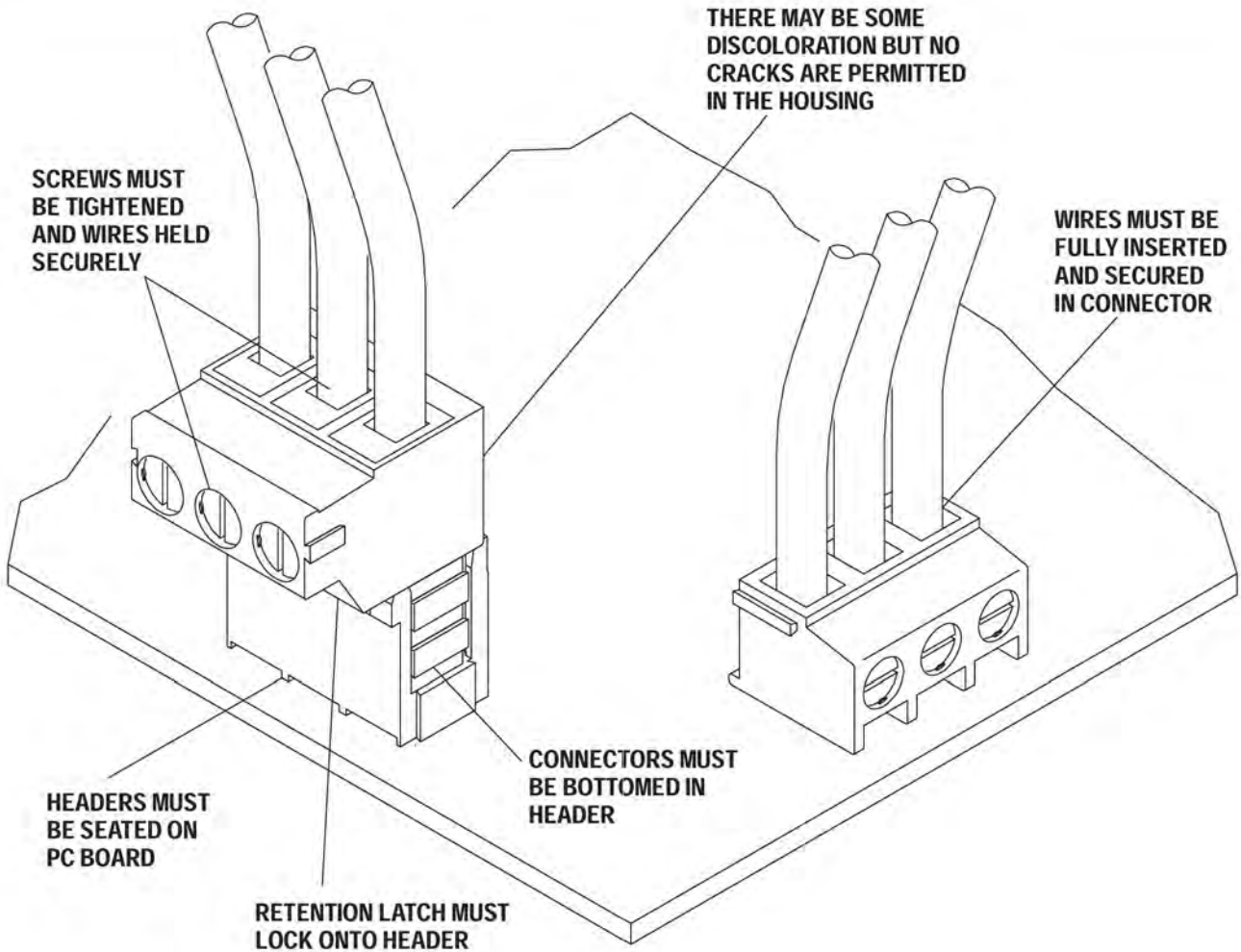

FIGURE 9. VISUAL AID