

PRODUCT NUMBER
76342-YXXXLF

WHEN NEEDED, SUFFIX LETTER "LF"
INDICATES THE PRODUCT IS RoHS
COMPATIBLE, SEE NOTE 10
OPTIONAL LETTER
H: HIGH TEMPERATURE PRODUCT.
C: PACKAGED IN SHORT TUBE.
NUMBER OF POSITIONS PER ROW: 02 TO 50.
PLATING CODE
3= 0.76µm GOLD ON CONTACT AREA.
3.81µm TIN-LEAD ON TAIL.
4= 5µm TIN-LEAD ON CONTACT AREA.
3.81µm TIN-LEAD ON TAIL.
WHEN SUFFIX "LF" IS REQUIRED, 2µm MIN MATTE
TIN OVER 1.27 MIN Ni IS SUPPLIED INSTEAD OF SnPb.

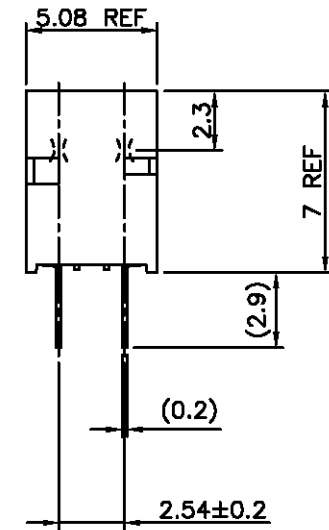
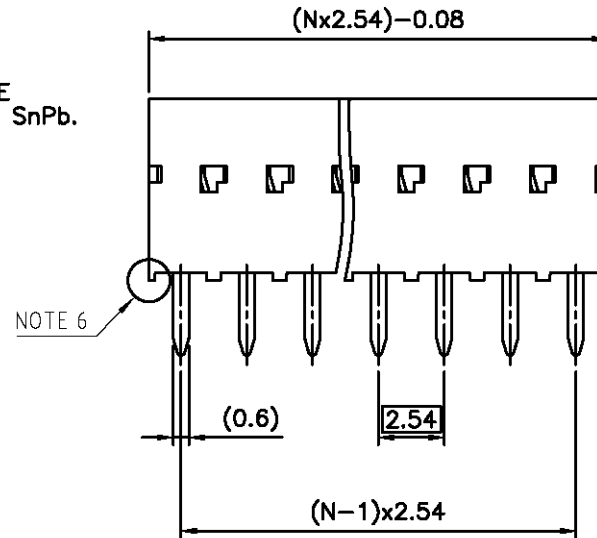
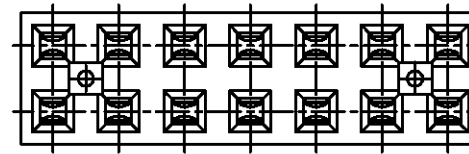

NOTES:

- 1 - HOUSING MAT'L: THERMOPLASTIC GLASS FILLED
FLAME RETARDANT PER UL 94 V-0
LOW TEMPERATURE: COLOR BLUE
HIGH TEMPERATURE: COLOR GREY.
 - 2 - TERMINAL MATERIAL: PHOSPHOR BRONZE.
 - 3 - 2 UP TO 4 POSITIONS PRODUCT PACKED IN PLASTIC BOX.
5 UP TO 50 POSITIONS PRODUCT PACKED IN TUBE.
 - 4 - TO DETERMINE DIMENSIONS:
N = NUMBER OF POSITIONS PER ROW
EXAMPLE: 8 POS: (Nx2.54)-0.08=20.24 mm
 - 5 - RoHS COMPATIBLE PRODUCT SPECIFICATIONS
 - a - PLATING:
 - "LF" MEANS THE PRODUCT IS LEAD-FREE,
2µm MINIMUM MATTE TIN OVER 1.27µm
MINIMUM NICKEL UNDERPLATE.
 - b - MANUFACTURING PROCESS COMPATIBILITY
 - THE HOUSING WILL WITHSTAND EXPOSURE TO
260°C ±5°C SOLDER BATH TEMPERATURE FOR
5 SECONDS IN A WAVE SOLDER APPLICATION
WITH A 1.6mm MIN THICK CIRCUIT BOARD.
 - c - LABELING:
 - MEETS PACKAGING SPECS AS PER GS-14-920
 - d - LEGAL STATEMENT: SEE GS-22-008
- 6 - END STAND-OFFS FOR 2x2 UP TO 2x5 POS
NO END STAND-OFFS FOR 2x6 UP TO 2x50 POS

mat'l. code SEE NOTES 1 & 2		surface ISO 1302	tolerance ISO 406 ISO 1101	projection mm	product family DUBOX
ltr	ecn no	dr	date	tolerances unless otherwise specified	title
S	F10342	DLE	01.06.12	angles linear ±0.3	BtB RECEPT. VERT DR TMT
T	F04-0347	DLE	04.09.27	±2°	
U	F06-0137	DLE	06.02.27	±2°	scale 5:1
V	F06-0204	DLE	06.06.20	dr D LEGRAND 04.09.27	dwg no 76342
W	F11-0043	JCO	12.02.22	engr P NIZZI 04.09.27	
R	F10110	GCO	01.01.16	chr D LEGRAND 04.09.27	sheet 1 of 2 size A3
sheet index	revision sheet	W	B	appd P NZ 04.09.27	type CUSTOMER Drawing
		1	2		

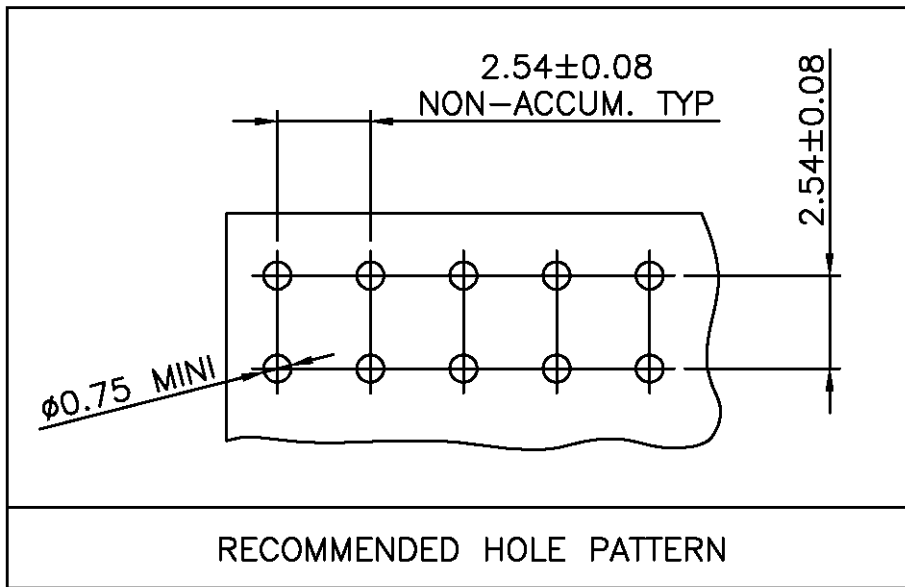

FCIconnect.com

PDM: Rev:W

STATUS: Released

Printed: Mar 20, 2012

Copyright FCI

mat'l. code SEE SHEET 1				surface ISO 1302 ✓		tolerance ISO 406 ISO 1101		projection 		product family DUBOX					
ltr	ecn no	dr	date	tolerances unless otherwise specified						title BtB RECEPT. VERT DR TMT					
A	F04-0347	DLE	04.09.27	angles	linear	±0.3		mm		scale 5:1		dwg no 76342		sheet 2 of 2 size A4	
B	F06-0204	DLE	06.06.20			±Z'									
				dr	D LEGRAND	04.09.27				type CUSTOMER Drawing					
				enr	P NIZZI	04.09.27									
				chr	D LE	04.09.27									
				appd	P NZ	04.09.27									
sheet index		revision sheet													