

The Model 75

75

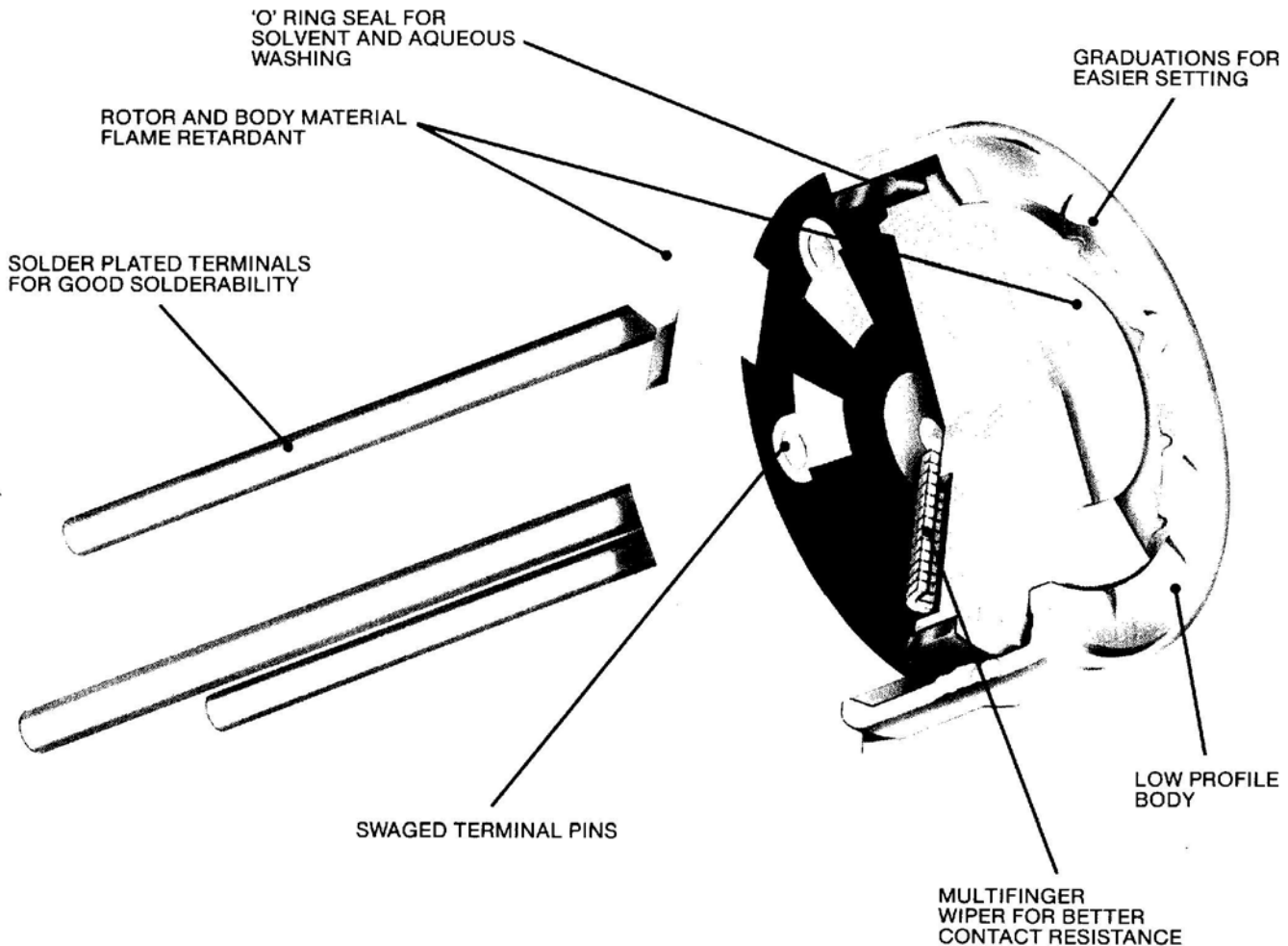

A 1/4" round (6mm) single turn cermet trimmer with features to make it your No. 1 choice from the SUPATRIM stable.

The new Model 75 offers a range of features to meet today's demanding reliability standards. Environmental and performance testing to MIL-Std-202 and MIL-R-22097 ensures high quality levels are maintained.

This very competitive product, which exhibits excellent setability and stability characteristics, is available in three standard pin styles for top or side adjust and resistance range between 10 ohms-2 Megohms with a tolerance of $\pm 10\%$

All these features make the 75 another true thoroughbred from the Spectrol Supatrim stable.

A Division of

Wabash
Magnetics

A Kearney-National Company

Spectrol[®]

Spectrol Reliance Limited, Garrard Way, Swindon, Wiltshire SN3 3HY Tel: 0793 521351 Telex: 494692 Fax: 0793 539255

MODEL 75

10Ω to 2. Megohms

TRIMMING POTENTIOMETERS

SPECIFICATIONS

ELECTRICAL

EFFECTIVE TRAVEL	230° ± 5°
RESISTANCE RANGE	10Ω thru 2 megohms
RESISTANCE TOLERANCE	±10%
END RESISTANCE	2Ω maximum
TEMPERATURE COEFFICIENT OF RESISTANCE	±100 ppm/°C, 100Ω thru 2 megohms
POWER RATING	0.5 watts at 70°C, derated linearly to zero watts at 125°C. Maximum voltage not to exceed 300 V.
DIELECTRIC WITHSTANDING VOLTAGE	600 VAC at sea level
INSULATION RESISTANCE	1000 megohms minimum (@ 500VDC)
CONTACT RESISTANCE VARIATION	3% or 3Ω whichever is greater
MAXIMUM WIPER CURRENT	100mA

MECHANICAL

STOP	Solid
TORQUE	200gcm max
RESISTANCE ELEMENT	Cermet

RESISTANCE VALUES - OHMS

10R, 20R, 50R, 100R, 200R, 500R, 1k, 2k, 5k, 10k, 20k, 50k, 100k, 200k, 500k, 1M, 2M.

MARKING

Unit Identification:
IEC resistance value coding, date code.

ENVIRONMENTAL

		MAX CHANGE		
		ΔR	Vab Vac	
CHANGE OF TEMPERATURE	-55°C to 125°C	±2%	±1%	Per MIL-R-22097
VIBRATION	20G	±1%	±1%	Per MIL-R-Std-202
ELECTRICAL ENDURANCE	1000 hour	±2%	±2%	Per MIL-R-Std-202
DAMP HEAT STEADY STATE	250 Hrs	±2%	-	Per MIL-R-Std-202
MECHANICAL LIFE	200 cycles	-	-	Per MIL-R-22097
SEALING	1 min @ 85°C	±1%	-	Per MIL-R-22097

75P

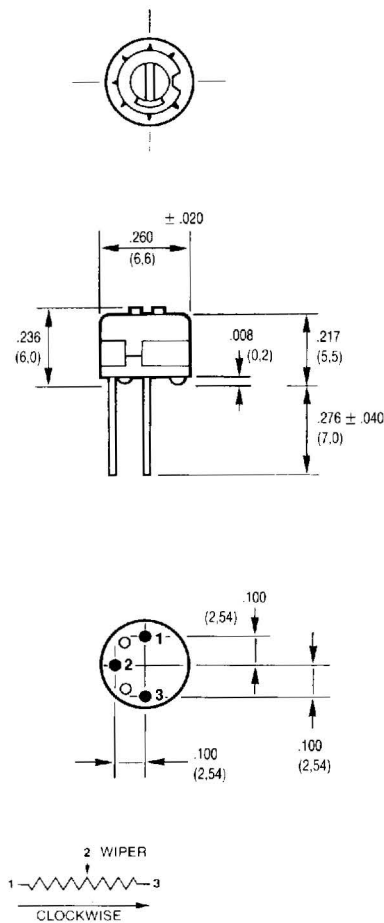

75H

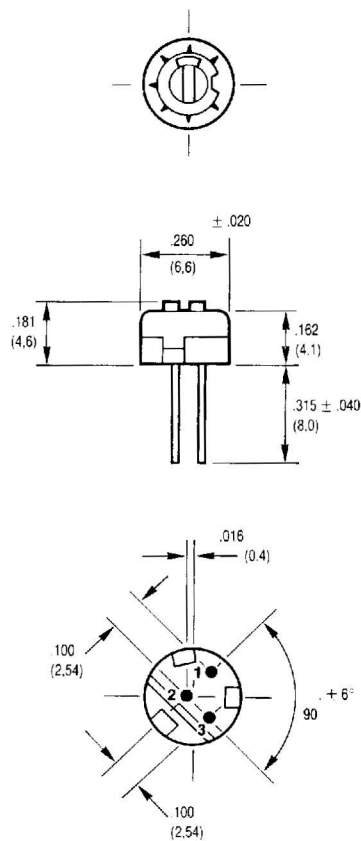

TOLERANCE ± .012 (0.3) EXCEPT WHERE NOTED
UNITS: INS (MM)

75T

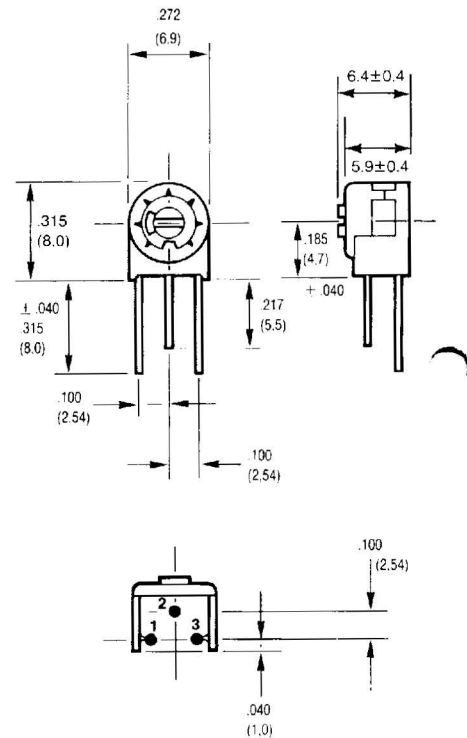

OTHER PIN STYLES AND TAPE AND REEL VERSIONS AVAILABLE – CONSULT FACTORY FOR DETAILS.

As a general policy Spectrol does not recommend the use of any of its products in life support applications where failure or malfunction of the Spectrol product can be reasonably expected to cause failure of the life support device or to significantly affect its safety or effectiveness.

A Division of

Wabash
Magnetics

A Kearney-National Company

Spectrol Reliance Ltd.
Garrard Way
Swindon, Wiltshire, England
Swindon 521351 ● Telex 494692
Fax: 0793 539255

Spectrol Electronics Corporation
17070 E. Gale Ave., P.O. Box 1220
City of Industry, Calif. 91749, U.S.A.
(213) 964-6565 ● TWX (910) 584-1314

Spectrol®