

74365A, 366A, 367A, 368A, LS365A, LS366A, LS367A, LS368A Buffers/Drivers

Logic Products

'365A, '367A Hex Buffer/Driver (3-State)
'366A, '368A Hex Inverter Buffer (3-State)
Product Specification

FUNCTION TABLE, '365A, '366A

INPUTS			OUTPUTS	
\overline{OE}_1	\overline{OE}_2	I	Y	\overline{Y}
L	L	L	L	H
L	L	H	H	L
X	H	X	(Z)	(Z)
H	X	X	(Z)	(Z)

FUNCTION TABLE, '367A, '368A

INPUTS		OUTPUTS	
\overline{OE}	I	Y	\overline{Y}
L	L	L	H
L	H	H	L
H	X	(Z)	(Z)

L = LOW voltage level
H = HIGH voltage level
X = Don't care
(Z) = HIGH impedance (off) state

TYPE	TYPICAL PROPAGATION DELAY	TYPICAL SUPPLY CURRENT (TOTAL)
74365A, 367A	10ns	65mA
74LS365A, 367A	10ns	14mA
74366A, 368A	9ns	59mA
74LS366A, 368A	10ns	12mA

ORDERING CODE

PACKAGES	COMMERCIAL RANGE
	$V_{CC} = 5V \pm 5\%$; $T_A = 0^\circ C$ to $+70^\circ C$
Plastic DIP	N74365AN, N74LS365AN, N74366AN, N74LS366AN N74367AN, N74LS367AN, N74368AN, N74LS368AN
Plastic SO-16	N74LS365AD, N74LS367AD, N74LS368AD

NOTE:

For information regarding devices processed to Military Specifications, see the Signetics Military Products Data Manual.

INPUT AND OUTPUT LOADING AND FAN-OUT TABLE

PINS	DESCRIPTION	74	74LS
All	Inputs	1ul	1LSul
All	Outputs	20ul	30LSul

NOTE:

Where a 74 unit load (ul) is understood to be $40\mu A I_{IH}$ and $-1.6mA I_{IL}$, and a 74LS unit load (LSul) is $20\mu A I_{IH}$ and $-0.4mA I_{IL}$.

PIN CONFIGURATION

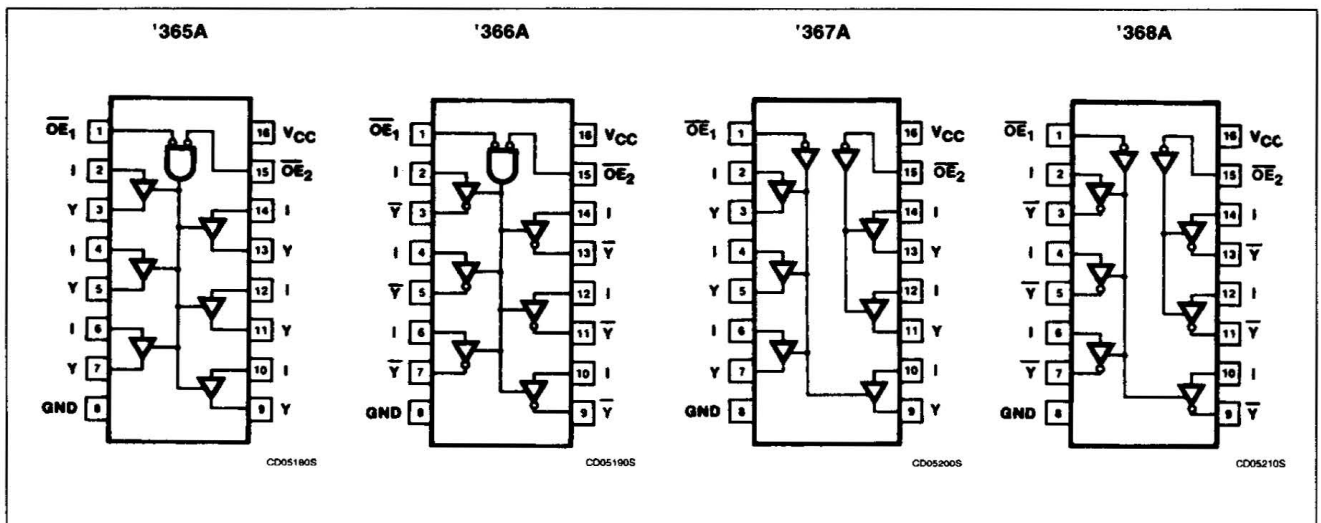

**74365A, 366A, 367A, 368A,
 LS365A, LS366A, LS367A, LS368A**

LOGIC SYMBOL

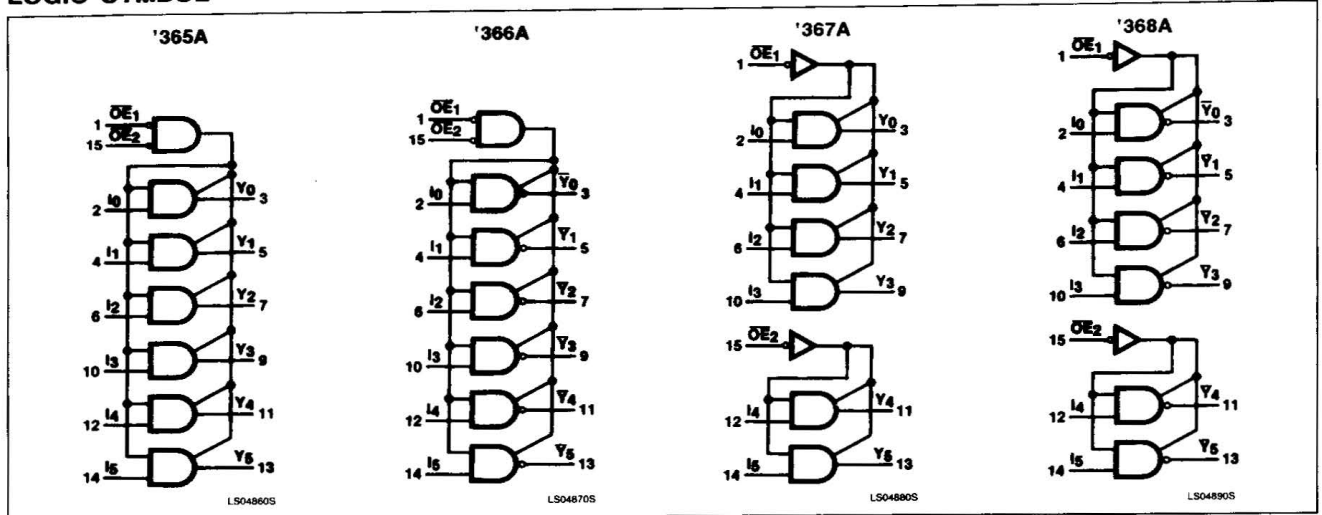

LOGIC SYMBOL (IEEE/IEC)

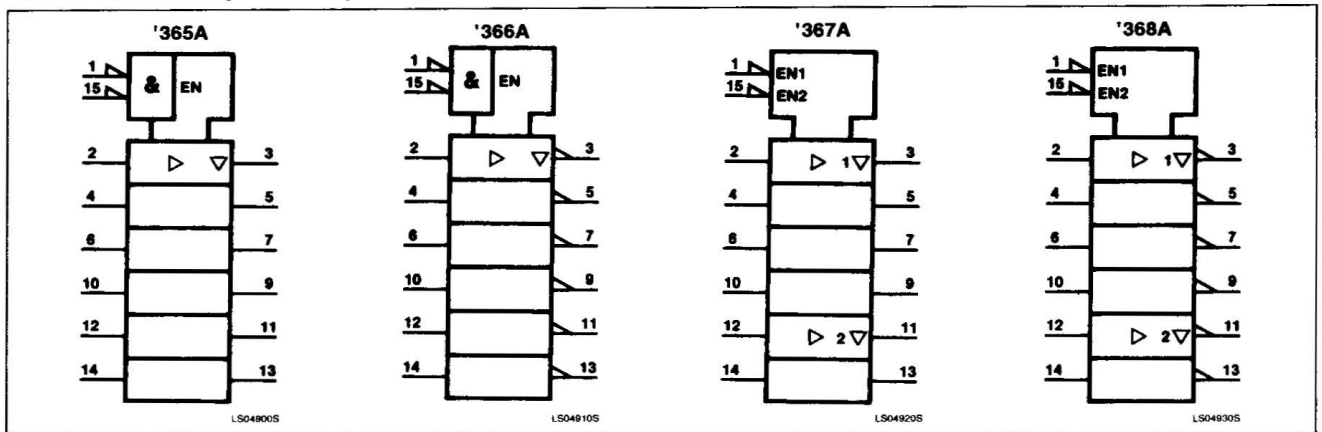

ABSOLUTE MAXIMUM RATINGS (Over operating free-air temperature range unless otherwise noted.)

PARAMETER		74	74LS	UNIT
V_{CC}	Supply voltage	7.0	7.0	V
V_{IN}	Input voltage	-0.5 to +5.5	-0.5 to +7.0	V
I_{IN}	Input current	-30 to +5	-30 to +1	mA
V_{OUT}	Voltage applied to output in HIGH output state	-0.5 to V_{CC}	-0.5 to V_{CC}	V
T_A	Operating free-air temperature range	0 to 70		°C

Buffers/Drivers

74365A, 366A, 367A, 368A,
LS365A, LS366A, LS367A, LS368A

RECOMMENDED OPERATING CONDITIONS

PARAMETER	74			74LS			UNIT
	Min	Nom	Max	Min	Nom	Max	
V _{CC} Supply voltage	4.75	5.0	5.25	4.75	5.0	5.25	V
V _{IH} HIGH-level input voltage	2.0			2.0			V
V _{IL} LOW-level input voltage			+0.8			+0.8	V
I _{IK} Input clamp current			-12			-18	mA
I _{OH} HIGH-level output current			-5.2			-2.6	mA
I _{OL} LOW-level output current			32			24	mA
T _A Operating free-air temperature	0		70	0		70	°C

DC ELECTRICAL CHARACTERISTICS (Over recommended operating free-air temperature range unless otherwise noted.)

PARAMETER	TEST CONDITIONS ¹	74365A, '366A, '367A, '368A			74LS365A, '366A, '367A, '368A			UNIT	
		Min	Typ ²	Max	Min	Typ ²	Max		
V _{OH} HIGH-level output voltage	V _{CC} = MIN, V _{IH} = MIN, V _{IL} = MAX, I _{OH} = MAX	2.4	3.1		2.4	3.1		V	
V _{OL} LOW-level output voltage	V _{CC} = MIN, V _{IH} = MIN, V _{IL} = MAX I _{OL} = MAX			0.4		0.35	0.5	V	
						0.25	0.4	V	
V _{IK} Input clamp voltage	V _{CC} = MIN, I _I = I _{IK}			-1.5			-1.5	V	
I _{OZH} Off-state output current HIGH-level voltage applied	V _{CC} = MAX, V _{IH} = MIN, V _{IL} = MAX, V _O = 2.4V			40			20	μA	
I _{OZL} Off-state output current, LOW-level voltage applied	V _{CC} = MAX, V _{IH} = MIN, V _{IL} = MAX, V _O = 0.4V			-40			-20	μA	
I _I Input current at maximum input voltage	V _{CC} = MAX	V _I = 5.5V			1.0			mA	
		V _I = 7.0V					0.1	mA	
I _{IH} HIGH-level input current	V _{CC} = MAX	V _I = 2.4V			40			μA	
		V _I = 2.7V					20	μA	
I _{IL} LOW-level input current	V _{CC} = MAX	1 inputs, V _I = 0.5V Either \overline{OE} input at 2.0V Does not apply to 'LS365A or 'LS367A			-40		-20	μA	
		1 inputs V _I = 0.4V Both \overline{OE} inputs at 0.4V			-1.6		-0.4	mA	
		\overline{OE} inputs V _I = 0.4V			-1.6		-0.4	mA	
I _{OS} Short-circuit output current ³	V _{CC} = MAX	-40		-130	-30		-130	mA	
I _{CC} Supply current ⁴ (total)	V _{CC} = MAX	'365A, '367A		65	85		14	24	mA
		'366A, '368A		59	77		12	21	mA

NOTES:

- For conditions shown as MIN or MAX, use the appropriate value specified under recommended operating conditions for the applicable type.
- All typical values are at V_{CC} = 5V, T_A = 25°C.
- I_{OS} is tested with V_{OUT} = +0.5V and V_{CC} = V_{CC} MAX + 0.5V. Not more than one output should be shorted at a time and duration of the short circuit should not exceed one second.
- Measure I_{CC} with Data inputs grounded and Output Enable inputs at 4.5V.

Buffers/Drivers

74365A, 366A, 367A, 368A,
LS365A, LS366A, LS367A, LS368A

AC ELECTRICAL CHARACTERISTICS $T_A = 25^\circ\text{C}$, $V_{CC} = 5.0\text{V}$

PARAMETER	TEST CONDITIONS	74		74LS		UNIT
		$C_L = 50\text{pF}$, $R_L = 400\Omega$		$C_L = 45\text{pF}$, $R_L = 667\Omega$		
		Min	Max	Min	Max	
t_{PLH} t_{PHL} Propagation delay	Waveform 1, '366A, '368A		17 16		15 18	ns
t_{PLH} t_{PHL} Propagation delay	Waveform 2, '365A, '367A		16 22		16 22	ns
t_{PZH} Enable to HIGH	Waveform 3		35		35	ns
t_{PZL} Enable to LOW	Waveform 4	'365A, '367A	37		40	ns
		'366A, '368A	37		45	ns
t_{PHZ} Disable from HIGH	Waveform 3, $C_L = 5\text{pF}$	'365A, '367A	11		30	ns
		'366A, '368A	11		32	ns
t_{PLZ} Disable from LOW	Waveform 4, $C_L = 5\text{pF}$		27		35	ns

AC WAVEFORMS

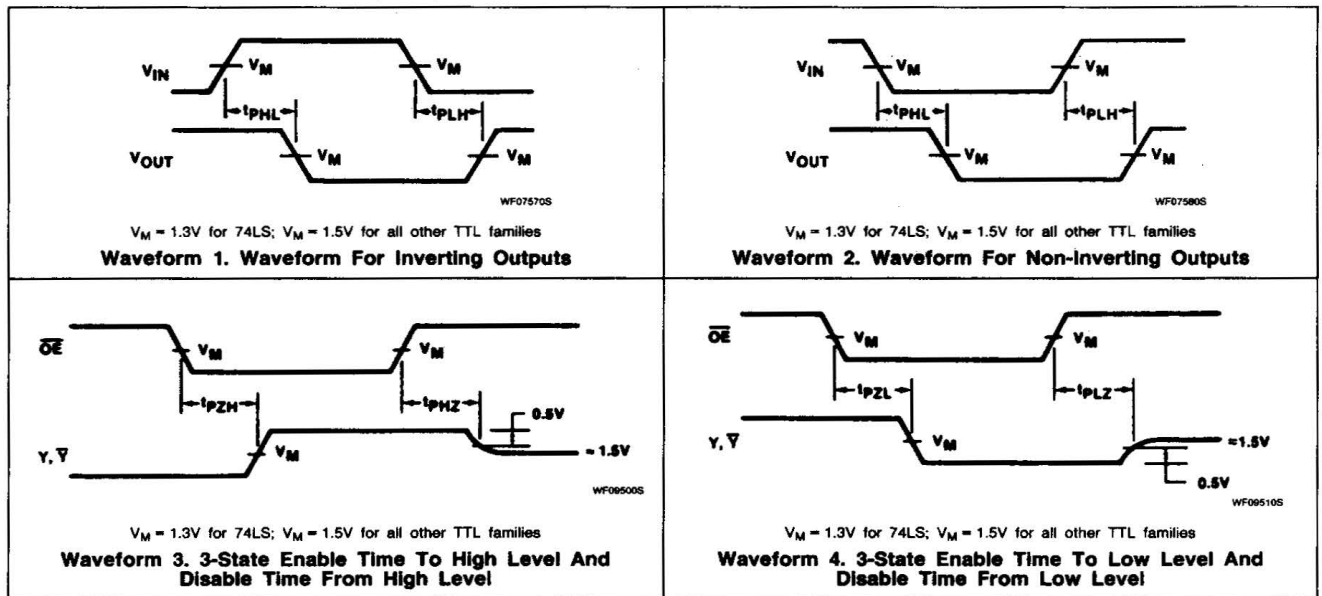

5

Buffers/Drivers

74365A, 366A, 367A, 368A,
LS365A, LS366A, LS367A, LS368A

TEST CIRCUITS AND WAVEFORMS

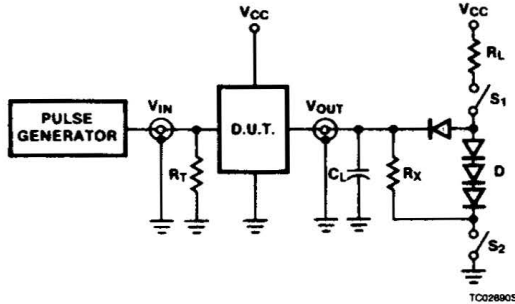

Test Circuit For 3-State Outputs

SWITCH POSITION

TEST	SWITCH 1	SWITCH 2
t _{PZH}	Open	Closed
t _{PZL}	Closed	Open
t _{PHZ}	Closed	Closed
t _{PLZ}	Closed	Closed

DEFINITIONS

R_L = Load resistor to V_{CC}; see AC CHARACTERISTICS for value.

C_L = Load capacitance includes jig and probe capacitance; see AC CHARACTERISTICS for value.

R_T = Termination resistance should be equal to Z_{OUT} of Pulse Generators.

D = Diodes are 1N916, 1N3064, or equivalent.

R_X = 1kΩ for 74, 74S, R_X = 5kΩ for 74LS.

t_{TLH}, t_{THL} Values should be less than or equal to the table entries.

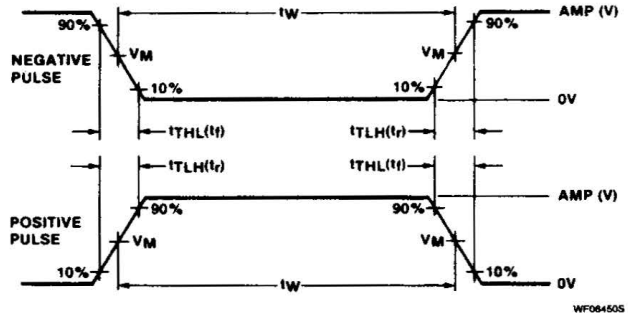

V_M = 1.3V for 74LS; V_M = 1.5V for all other TTL families.

Input Pulse Definition

FAMILY	INPUT PULSE REQUIREMENTS				
	Amplitude	Rep. Rate	Pulse Width	t _{TLH}	t _{THL}
74	3.0V	1MHz	500ns	7ns	7ns
74LS	3.0V	1MHz	500ns	15ns	6ns
74S	3.0V	1MHz	500ns	2.5ns	2.5ns