

DATA SHEET

74HC74; 74HCT74

Dual D-type flip-flop with set and reset; positive-edge trigger

Product specification
Supersedes data of 1998 Feb 23

2003 Jul 10

Dual D-type flip-flop with set and reset; positive-edge trigger

74HC74; 74HCT74

FEATURES

- Wide supply voltage range from 2.0 to 6.0 V
- Symmetrical output impedance
- High noise immunity
- Low power dissipation
- Balanced propagation delays
- ESD protection:
HBM EIA/JESD22-A114-A exceeds 2000 V
MM EIA/JESD22-A115-A exceeds 200 V.

GENERAL DESCRIPTION

The 74HC/HCT74 is a high-speed Si-gate CMOS device and is pin compatible with low power Schottky TTL (LSTTL). They are specified in compliance with JEDEC standard no. 7A.

The 74HC/HCT74 are dual positive-edge triggered, D-type flip-flops with individual data (D) inputs, clock (CP) inputs, set (\overline{SD}) and reset (\overline{RD}) inputs; also complementary Q and \overline{Q} outputs.

The set and reset are asynchronous active LOW inputs and operate independently of the clock input. Information on the data input is transferred to the Q output on the LOW-to-HIGH transition of the clock pulse. The D inputs must be stable one set-up time prior to the LOW-to-HIGH clock transition for predictable operation.

Schmitt-trigger action in the clock input makes the circuit highly tolerant to slower clock rise and fall times.

QUICK REFERENCE DATA

GND = 0 V; $T_{amb} = 25\text{ }^{\circ}\text{C}$; $t_r = t_f = 6\text{ ns}$

SYMBOL	PARAMETER	CONDITIONS	TYPICAL		UNIT
			HC	HCT	
t_{PHL}/t_{PLH}	propagation delay nCP to nQ, n \overline{Q}	$C_L = 15\text{ pF}$; $V_{CC} = 5\text{ V}$	14	15	ns
	n \overline{SD} to nQ, n \overline{Q}		15	18	ns
	n \overline{RD} to nQ, n \overline{Q}		16	18	ns
f_{max}	maximum clock frequency		76	59	MHz
C_I	input capacitance		3.5	3.5	pF
C_{PD}	power dissipation capacitance per flip-flop	notes 1 and 2	24	29	pF

Notes

1. C_{PD} is used to determine the dynamic power dissipation (P_D in μW).

$$P_D = C_{PD} \times V_{CC}^2 \times f_i \times N + \Sigma(C_L \times V_{CC}^2 \times f_o) \text{ where:}$$

f_i = input frequency in MHz;

f_o = output frequency in MHz;

C_L = output load capacitance in pF;

V_{CC} = supply voltage in Volts;

N = total load switching outputs;

$\Sigma(C_L \times V_{CC}^2 \times f_o)$ = sum of the outputs.

2. For 74HC74 the condition is $V_I = \text{GND to } V_{CC}$.

For 74HCT74 the condition is $V_I = \text{GND to } V_{CC} - 1.5\text{ V}$.

Dual D-type flip-flop with set and reset; positive-edge trigger

74HC74; 74HCT74

FUNCTION TABLES

Table 1 See note 1

INPUT				OUTPUT	
$\bar{S}D$	$\bar{R}D$	CP	D	Q	\bar{Q}
L	H	X	X	H	L
H	L	X	X	L	H
L	L	X	X	H	H

Table 2 See note 1

INPUT				OUTPUT	
$\bar{S}D$	$\bar{R}D$	CP	D	Q _{n+1}	\bar{Q}_{n+1}
H	H	↑	L	L	H
H	H	↑	H	H	L

Note

- H = HIGH voltage level;
L = LOW voltage level;
X = don't care;
↑ = LOW-to-HIGH CP transition;
Q_{n+1} = state after the next LOW-to-HIGH CP transition.

ORDERING INFORMATION

TYPE NUMBER	PACKAGE				
	TEMPERATURE RANGE	PINS	PACKAGE	MATERIAL	CODE
74HC74N	-40 to +125 °C	14	DIP14	plastic	SOT27-1
74HCT74N	-40 to +125 °C	14	DIP14	plastic	SOT27-1
74HC74D	-40 to +125 °C	14	SO14	plastic	SOT108-1
74HCT74D	-40 to +125 °C	14	SO14	plastic	SOT108-1
74HC74DB	-40 to +125 °C	14	SSOP14	plastic	SOT337-1
74HCT74DB	-40 to +125 °C	14	SSOP14	plastic	SOT337-1
74HC74PW	-40 to +125 °C	14	TSSOP14	plastic	SOT402-1
74HCT74PW	-40 to +125 °C	14	TSSOP14	plastic	SOT402-1
74HC74BQ	-40 to +125 °C	14	DHVQFN14	plastic	SOT762-1
74HCT74BQ	-40 to +125 °C	14	DHVQFN14	plastic	SOT762-1

Dual D-type flip-flop with set and reset; positive-edge trigger

74HC74; 74HCT74

PINNING

PIN	SYMBOL	DESCRIPTION
1	1 $\overline{\text{RD}}$	asynchronous reset-direct input (active LOW)
2	1D	data input
3	1CP	clock input (LOW-to-HIGH, edge-triggered)
4	1 $\overline{\text{SD}}$	asynchronous set-direct input (active LOW)
5	1Q	true flip-flop output
6	1 $\overline{\text{Q}}$	complement flip-flop output
7	GND	ground (0 V)
8	2 $\overline{\text{Q}}$	complement flip-flop output
9	2Q	true flip-flop output
10	2 $\overline{\text{SD}}$	asynchronous set-direct input (active LOW)
11	2CP	clock input (LOW-to-HIGH, edge-triggered)
12	2D	data input
13	2 $\overline{\text{RD}}$	asynchronous reset-direct input (active LOW)
14	V _{CC}	positive supply voltage

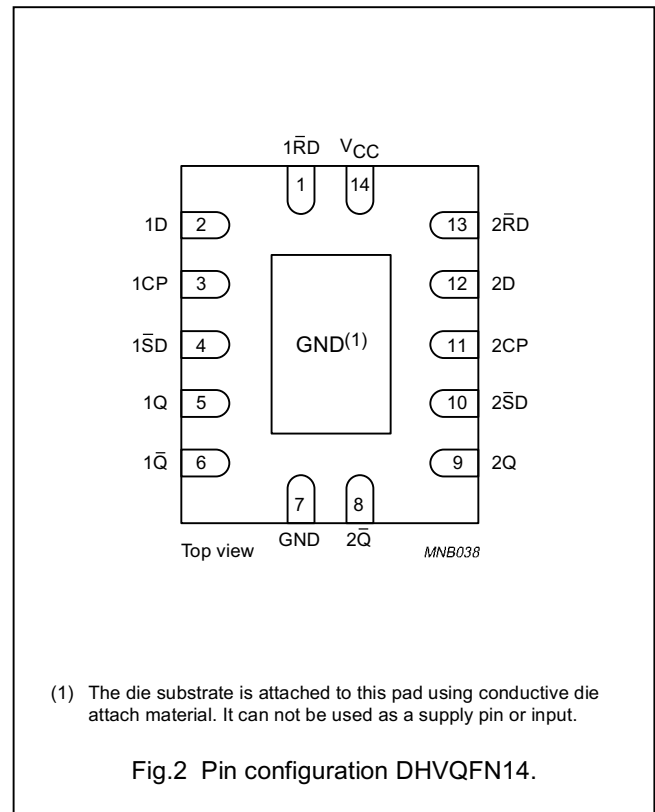
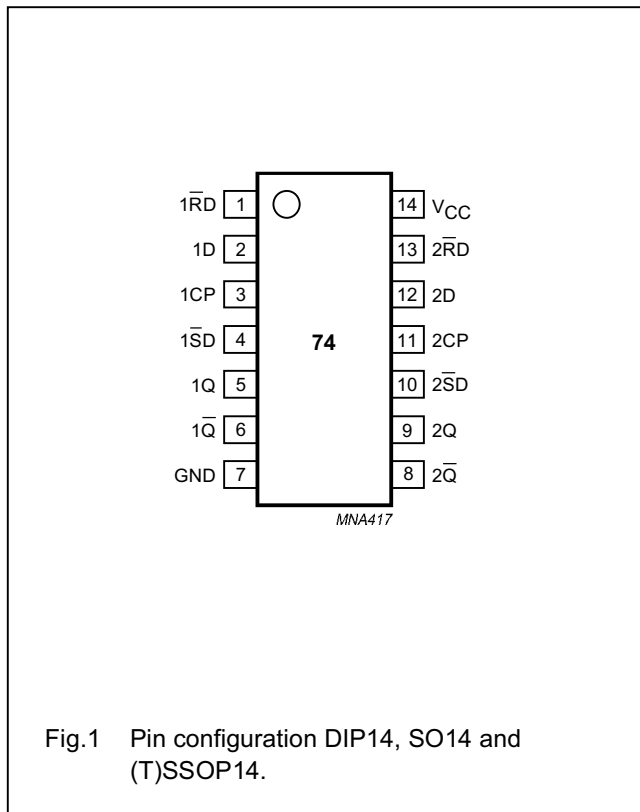

Dual D-type flip-flop with set and reset;
positive-edge trigger

74HC74; 74HCT74

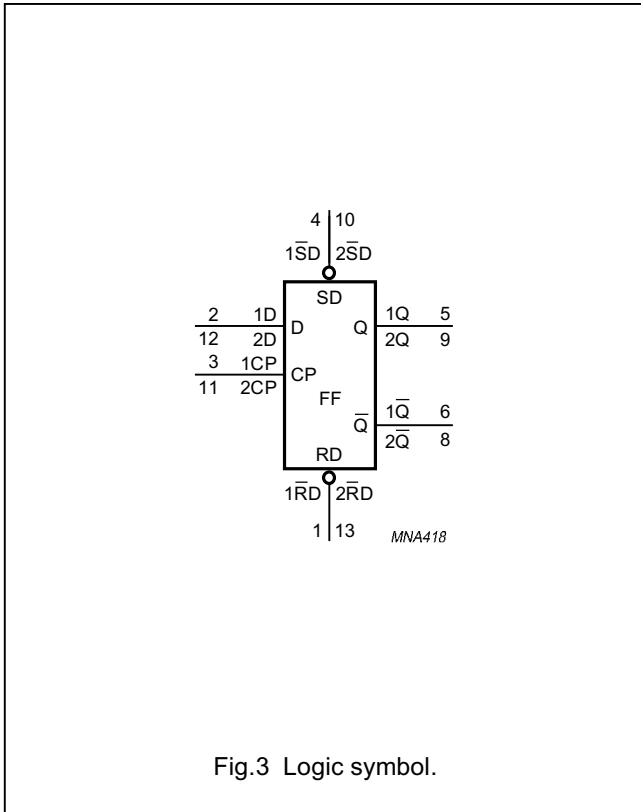

Fig.3 Logic symbol.

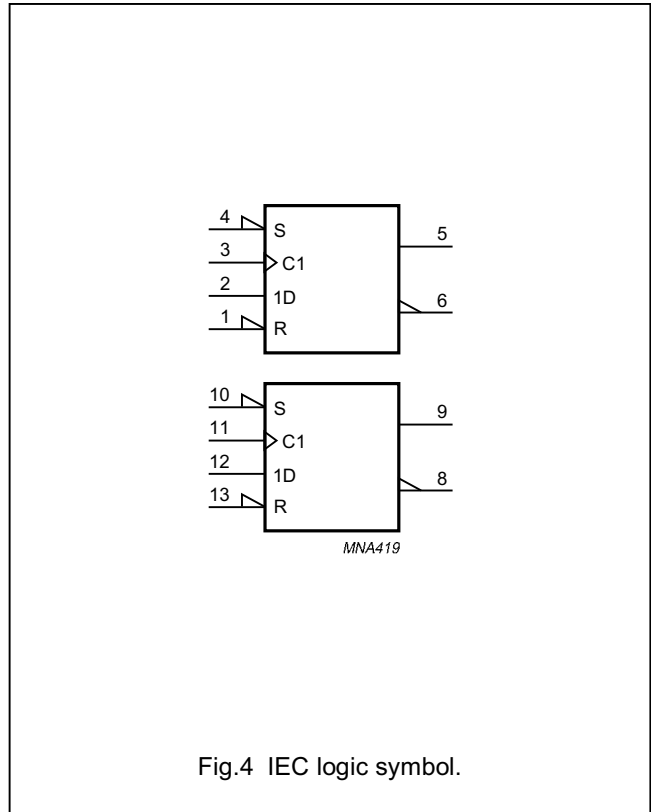

Fig.4 IEC logic symbol.

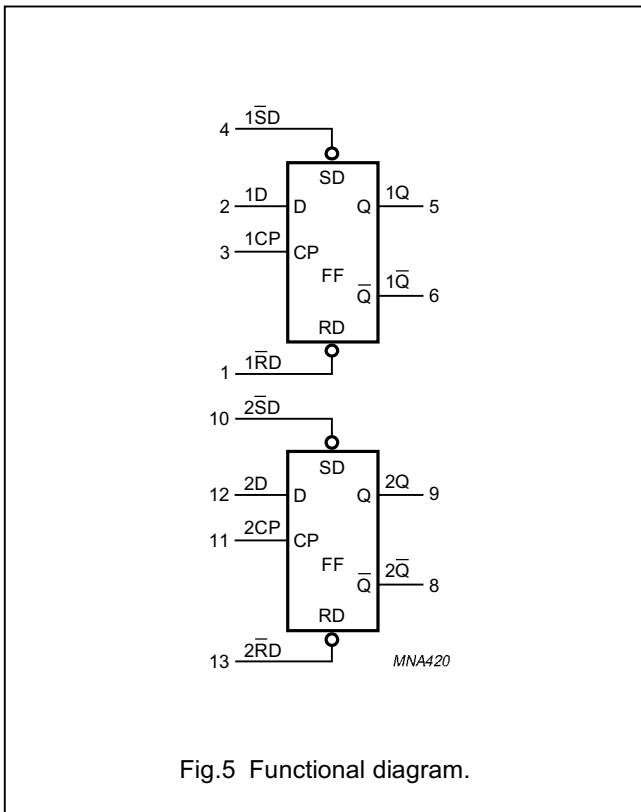

Fig.5 Functional diagram.

Dual D-type flip-flop with set and reset;
positive-edge trigger

74HC74; 74HCT74

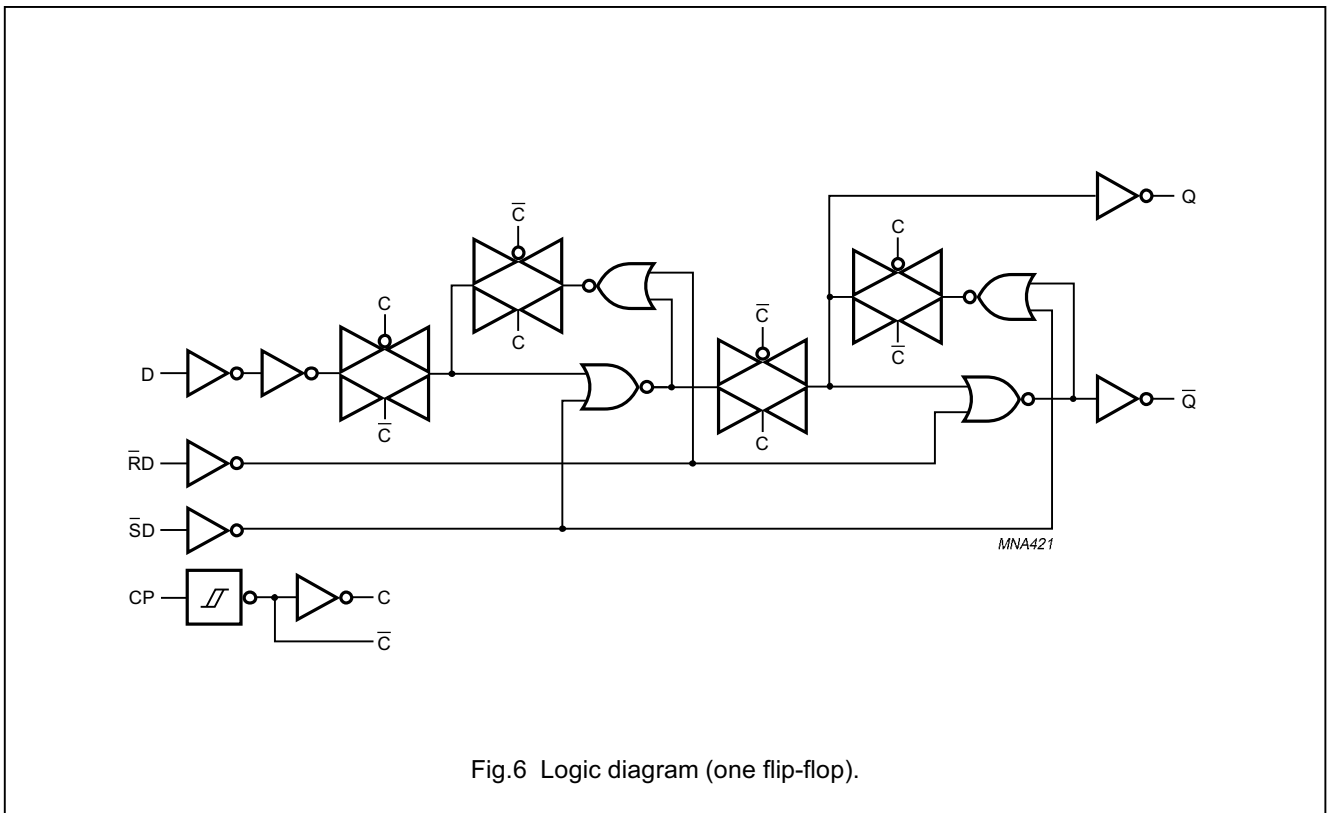

Fig.6 Logic diagram (one flip-flop).

Dual D-type flip-flop with set and reset;
positive-edge trigger

74HC74; 74HCT74

RECOMMENDED OPERATING CONDITIONS

SYMBOL	PARAMETER	CONDITIONS	74HC74			74HCT74			UNIT
			MIN.	TYP.	MAX.	MIN.	TYP.	MAX.	
V_{CC}	supply voltage		2.0	5.0	6.0	4.5	5.0	5.5	V
V_I	input voltage		0	–	V_{CC}	0	–	V_{CC}	V
V_O	output voltage		0	–	V_{CC}	0	–	V_{CC}	V
T_{amb}	operating ambient temperature		–40	+25	+125	–40	+25	+125	°C
t_r, t_f	input rise and fall times	$V_{CC} = 2.0\text{ V}$	–	–	1000	–	–	500	ns
		$V_{CC} = 4.5\text{ V}$	–	6.0	500	–	6.0	500	ns
		$V_{CC} = 6.0\text{ V}$	–	–	400	–	–	500	ns

LIMITING VALUES

In accordance with the Absolute Maximum Rating System (IEC 60134); voltages are referenced to GND (ground = 0 V).

SYMBOL	PARAMETER	CONDITIONS	MIN.	MAX.	UNIT
V_{CC}	supply voltage		–0.5	+7.0	V
I_{IK}	input diode current	$V_I < -0.5\text{ V}$ or $V_I > V_{CC} + 0.5\text{ V}$; note 1	–	±20	mA
I_{OK}	output diode current	$V_O < -0.5\text{ V}$ or $V_O > V_{CC} + 0.5\text{ V}$; note 1	–	±20	mA
I_O	output source or sink current	$-0.5\text{ V} < V_O < V_{CC} + 0.5\text{ V}$; note 1	–	±25	mA
I_{CC}, I_{GND}	V_{CC} or GND current		–	±100	mA
T_{stg}	storage temperature		–65	+150	°C
P_{tot}	power dissipation	$T_{amb} = -40\text{ to }+125\text{ °C}$; note 2	–	500	mW

Notes

- The input and output voltage ratings may be exceeded if the input and output current ratings are observed.
- For SO14 packages: above 70 °C derate linearly with 8 mW/K.
For SSOP14 and TSSOP14 packages: above 60 °C derate linearly with 5.5 mW/K.
For DHVQFN14 packages: above 60 °C derate linearly with 4.5 mW/K.
For DIP14 packages: above 70 °C derate linearly with 12 mW/K.

Dual D-type flip-flop with set and reset;
positive-edge trigger

74HC74; 74HCT74

DC CHARACTERISTICS

Family 74HC

At recommended operating conditions; voltages are referenced to GND (ground = 0 V).

SYMBOL	PARAMETER	TEST CONDITIONS		MIN.	TYP.	MAX.	UNIT
		WAVEFORMS	V _{CC} (V)				
T_{amb} = -40 to +85 °C; note 1							
V _{IH}	HIGH-level input voltage		2.0	1.5	1.2	–	V
			4.5	3.15	2.4	–	V
			6.0	4.2	3.2	–	V
V _{IL}	LOW-level input voltage		2.0	–	0.8	0.5	V
			4.5	–	2.1	1.35	V
			6.0	–	2.8	1.8	V
V _{OH}	HIGH-level output voltage	V _I = V _{IH} or V _{IL} I _O = -4.0 mA	4.5	3.84	4.32	–	V
		I _O = -5.2 mA	6.0	5.34	5.81	–	V
V _{OL}	LOW-level output voltage	V _I = V _{IH} or V _{IL} I _O = 4.0 mA	4.5	–	0.15	0.33	V
		I _O = 5.2 mA	6.0	–	0.16	0.33	V
I _{LI}	input leakage current	V _I = V _{CC} or GND	6.0	–	–	±1.0	µA
I _{CC}	quiescent supply current	V _I = V _{CC} or GND; I _O = 0	6.0	–	–	40	µA
T_{amb} = -40 to +125 °C							
V _{IH}	HIGH-level input voltage		2.0	1.5	–	–	V
			4.5	3.15	–	–	V
			6.0	4.2	–	–	V
V _{IL}	LOW-level input voltage		2.0	–	–	0.5	V
			4.5	–	–	1.35	V
			6.0	–	–	1.8	V
V _{OH}	HIGH-level output voltage	V _I = V _{IH} or V _{IL} I _O = -4.0 mA	4.5	3.7	–	–	V
		I _O = -5.2 mA	6.0	5.2	–	–	V
V _{OL}	LOW-level output voltage	V _I = V _{IH} or V _{IL} I _O = 4.0 mA	4.5	–	–	0.4	V
		I _O = 5.2 mA	6.0	–	–	0.4	V
I _{LI}	input leakage current	V _I = V _{CC} or GND	6.0	–	–	±1.0	µA
I _{CC}	quiescent supply current	V _I = V _{CC} or GND; I _O = 0	6.0	–	–	80	µA

Note

1. All typical values are measured at T_{amb} = 25 °C.

Dual D-type flip-flop with set and reset;
positive-edge trigger

74HC74; 74HCT74

Family 74HCT

At recommended operating conditions; voltages are referenced to GND (ground = 0 V).

SYMBOL	PARAMETER	TEST CONDITIONS		MIN.	TYP.	MAX.	UNIT
		WAVEFORMS	V _{CC} (V)				
T_{amb} = -40 to +85 °C; note 1							
V _{IH}	HIGH-level input voltage		4.5 to 5.5	2.0	1.6	–	V
V _{IL}	LOW-level input voltage		4.5 to 5.5	–	1.2	0.8	V
V _{OH}	HIGH-level output voltage	V _I = V _{IH} or V _{IL} ; I _O = -4.0 mA	4.5	3.84	4.32	–	V
V _{OL}	LOW-level output voltage	V _I = V _{IH} or V _{IL} ; I _O = 4.0 mA	4.5	0.33	0.15	–	V
I _{LI}	input leakage current	V _I = V _{CC} or GND	5.5	–	–	±1.0	μA
I _{CC}	quiescent supply current	V _I = V _{CC} or GND; I _O = 0	5.5	–	–	40	μA
ΔI _{CC}	additional quiescent supply current per input	V _I = V _{CC} -2.1 V other inputs at V _{CC} or GND; I _O = 0	4.5 to 5.5	–	100	450	μA
T_{amb} = -40 to +125 °C							
V _{IH}	HIGH-level input voltage		4.5 to 5.5	2.0	–	–	V
V _{IL}	LOW-level input voltage		4.5 to 5.5	–	–	0.8	V
V _{OH}	HIGH-level output voltage	V _I = V _{IH} or V _{IL} ; I _O = -4.0 mA	4.5	3.7	–	–	V
V _{OL}	LOW-level output voltage	V _I = V _{IH} or V _{IL} ; I _O = 4.0 mA	4.5	–	–	0.4	V
I _{LI}	input leakage current	V _I = V _{CC} or GND	5.5	–	–	±1.0	μA
I _{CC}	quiescent supply current	V _I = V _{CC} or GND; I _O = 0	5.5	–	–	80	μA
ΔI _{CC}	additional quiescent supply current per input	V _I = V _{CC} -2.1 V other inputs at V _{CC} or GND; I _O = 0	4.5 to 5.5	–	–	490	μA

Note

1. All typical values are measured at T_{amb} = 25 °C.

Remark to HCT types

The value of additional quiescent supply current (ΔI_{CC}) for a unit load of 1 is given here. To determine ΔI_{CC} per input, multiply this value by the unit load coefficient shown in the table.

INPUT	UNIT LOAD COEFFICIENT
nD	0.70
nRD	0.70
nSD	0.80
nCP	0.80

Dual D-type flip-flop with set and reset;
positive-edge trigger

74HC74; 74HCT74

AC CHARACTERISTICS

Family 74HC

GND = 0 V; $t_r = t_f = 6$ ns; $C_L = 50$ pF.

SYMBOL	PARAMETER	TEST CONDITIONS		MIN.	TYP.	MAX.	UNIT
		WAVEFORMS	V _{CC} (V)				
T_{amb} = -40 to +85 °C							
t _{PHL} /t _{PLH}	propagation delay nCP to nQ, nQ̄	see Fig.7	2.0	–	47	220	ns
			4.5	–	17	44	ns
			6.0	–	14	37	ns
	propagation delay nSD to nQ, nQ̄	see Fig.8	2.0	–	50	250	ns
			4.5	–	18	50	ns
			6.0	–	14	43	ns
	propagation delay nRD to nQ, nQ̄	see Fig.8	2.0	–	52	250	ns
			4.5	–	19	50	ns
			6.0	–	15	43	ns
t _{THL} /t _{TLH}	output transition time	see Fig.7	2.0	–	19	95	ns
			4.5	–	7	19	ns
			6.0	–	6	16	ns
t _w	clock pulse width HIGH or LOW	see Fig.7	2.0	100	19	–	ns
			4.5	20	7	–	ns
			6.0	17	6	–	ns
	set or reset pulse width LOW	see Fig.8	2.0	100	19	–	ns
			4.5	20	7	–	ns
			6.0	17	6	–	ns
t _{rem}	removal time set or reset	see Fig.8	2.0	40	3	–	ns
			4.5	8	1	–	ns
			6.0	7	1	–	ns
t _{su}	set-up time nD to nCP	see Fig.7	2.0	75	6	–	ns
			4.5	15	2	–	ns
			6.0	13	2	–	ns
t _h	hold time nCP to nD	see Fig.7	2.0	3	–6	–	ns
			4.5	3	–2	–	ns
			6.0	3	–2	–	ns
f _{max}	maximum clock pulse frequency	see Fig.7	2.0	4.8	23	–	MHz
			4.5	24	69	–	MHz
			6.0	28	82	–	MHz

Dual D-type flip-flop with set and reset;
positive-edge trigger

74HC74; 74HCT74

SYMBOL	PARAMETER	TEST CONDITIONS		MIN.	TYP.	MAX.	UNIT
		WAVEFORMS	V _{CC} (V)				
T_{amb} = -40 to +125 °C							
t _{PHL} /t _{PLH}	propagation delay nCP to nQ, n \bar{Q}	see Fig.7	2.0	–	–	265	ns
			4.5	–	–	53	ns
			6.0	–	–	45	ns
	propagation delay n \bar{SD} to nQ, n \bar{Q}	see Fig.8	2.0	–	–	300	ns
			4.5	–	–	60	ns
			6.0	–	–	51	ns
	propagation delay nRD to nQ, n \bar{Q}	see Fig.8	2.0	–	–	300	ns
			4.5	–	–	60	ns
			6.0	–	–	51	ns
t _{THL} /t _{TLH}	output transition time	see Fig.7	2.0	–	–	110	ns
			4.5	–	–	22	ns
			6.0	–	–	19	ns
t _w	clock pulse width HIGH or LOW	see Fig.7	2.0	120	–	–	ns
			4.5	24	–	–	ns
			6.0	20	–	–	ns
t _w	set or reset pulse width LOW	see Fig.8	2.0	120	–	–	ns
			4.5	24	–	–	ns
			6.0	20	–	–	ns
t _{rem}	removal time set or reset	see Fig.8	2.0	45	–	–	ns
			4.5	9	–	–	ns
			6.0	8	–	–	ns
t _{su}	set-up time nD to nCP	see Fig.7	2.0	90	–	–	ns
			4.5	18	–	–	ns
			6.0	15	–	–	ns
t _h	hold time nCP to nD	see Fig.7	2.0	3	–	–	ns
			4.5	3	–	–	ns
			6.0	3	–	–	ns
f _{max}	maximum clock pulse frequency	see Fig.7	2.0	4.0	–	–	MHz
			4.5	20	–	–	MHz
			6.0	24	–	–	MHz

Dual D-type flip-flop with set and reset;
positive-edge trigger

74HC74; 74HCT74

Family 74HCT

GND = 0 V; $t_r = t_f = 6$ ns; $C_L = 50$ pF.

SYMBOL	PARAMETER	TEST CONDITIONS		MIN.	TYP.	MAX.	UNIT
		WAVEFORMS	V _{CC} (V)				
T_{amb} = -40 to +85 °C							
t _{PHL} /t _{PLH}	propagation delay nCP to nQ, n \bar{Q}	see Fig.7	4.5	-	18	44	ns
	propagation delay n \bar{SD} to nQ, n \bar{Q}	see Fig.8	4.5	-	23	50	ns
	propagation delay n \bar{RD} to nQ, n \bar{Q}	see Fig.8	4.5	-	24	50	ns
t _{THL} /t _{TLH}	output transition time	see Fig.7	4.5	-	7	19	ns
t _W	clock pulse width HIGH or LOW	see Fig.7	4.5	23	9	-	ns
	set or reset pulse width LOW	see Fig.8	4.5	20	9	-	ns
t _{rem}	removal time set or reset	see Fig.8	4.5	8	1	-	ns
t _{su}	set-up time nD to nCP	see Fig.7	4.5	15	5	-	ns
t _h	hold time nCP to nD	see Fig.7	4.5	+3	-3	-	ns
f _{max}	maximum clock pulse frequency	see Fig.7	4.5	22	54	-	MHz
T_{amb} = -40 to +125 °C							
t _{PHL} /t _{PLH}	propagation delay nCP to nQ, n \bar{Q}	see Fig.7	4.5	-	-	53	ns
	propagation delay n \bar{SD} to nQ, n \bar{Q}	see Fig.8	4.5	-	-	60	ns
	propagation delay n \bar{RD} to nQ, n \bar{Q}	see Fig.8	4.5	-	-	60	ns
t _{THL} /t _{TLH}	output transition time	see Fig.7	4.5	-	-	22	ns
t _W	clock pulse width HIGH or LOW	see Fig.7	4.5	27	-	-	ns
	set or reset pulse width LOW	see Fig.8	4.5	24	-	-	ns
t _{rem}	removal time set or reset	see Fig.8	4.5	9	-	-	ns
t _{su}	set-up time nD to nCP	see Fig.7	4.5	18	-	-	ns
t _h	hold time nCP to nD	see Fig.7	4.5	3	-	-	ns
f _{max}	maximum clock pulse frequency	see Fig.7	4.5	18	-	-	MHz

Dual D-type flip-flop with set and reset; positive-edge trigger

74HC74; 74HCT74

AC WAVEFORMS

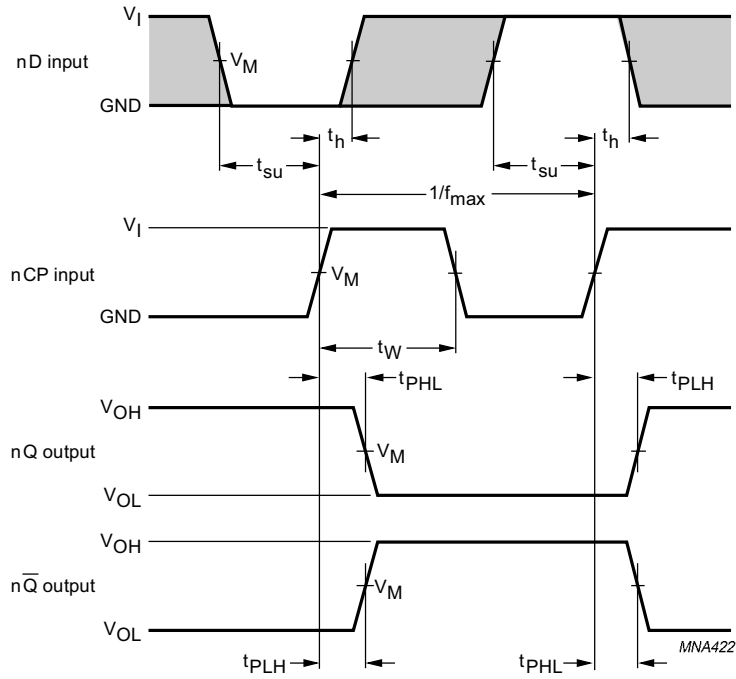

The shaded areas indicate when the input is permitted to change for predictable output performance.
74HC74: $V_M = 50\%$; $V_I = \text{GND to } V_{CC}$.
74HCT74: $V_M = 1.3 \text{ V}$; $V_I = \text{GND to } 3 \text{ V}$.

Fig.7 The clock (nCP) to output (nQ, nQ-bar) propagation delays, the clock pulse width, the nD to nCP set-up, the nCP to nD hold times, the output transition times and the maximum clock pulse frequency.

Dual D-type flip-flop with set and reset;
positive-edge trigger

74HC74; 74HCT74

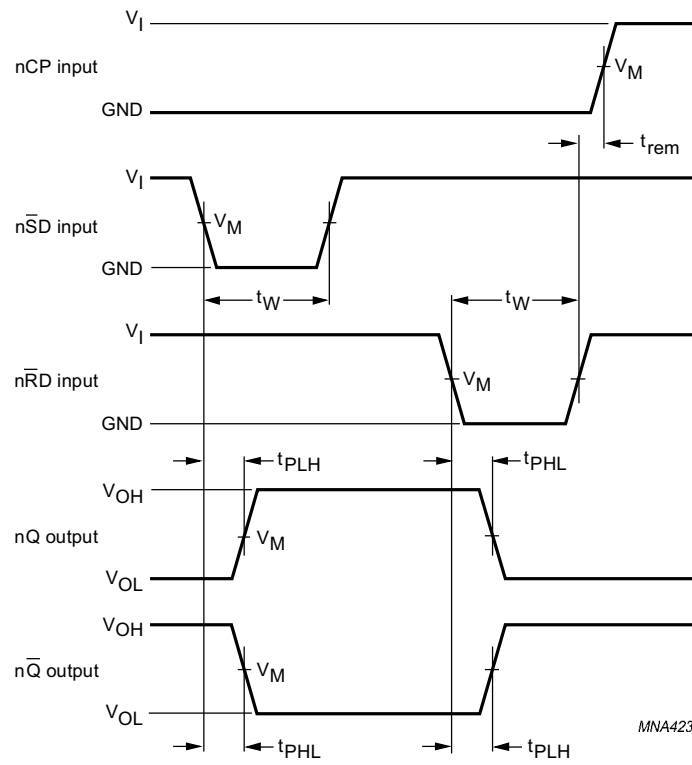

74HC74: $V_M = 50\%$; $V_I = \text{GND to } V_{CC}$.
74HCT74: $V_M = 1.3 \text{ V}$; $V_I = \text{GND to } 3 \text{ V}$.

Fig.8 The set (\overline{nSD}) and reset (\overline{nRD}) input to output (nQ , \overline{nQ}) propagation delays, the set and reset pulse widths and the \overline{nRD} , \overline{nRD} to nCP removal time.

Dual D-type flip-flop with set and reset;
positive-edge trigger

74HC74; 74HCT74

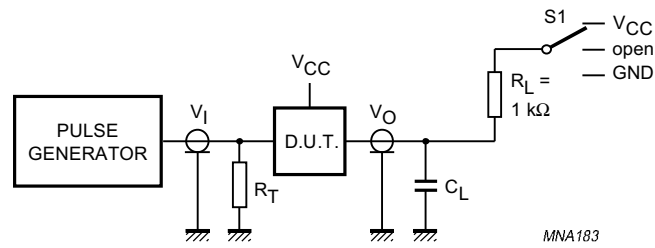

TEST	S1
t_{PZH}	GND
t_{PZL}	V_{CC}
t_{PHZ}	GND
t_{PLZ}	V_{CC}

Definitions for test circuit:

R_L = Load resistor.

C_L = Load capacitance including jig and probe capacitance.

R_T = Termination resistance should be equal to the output impedance Z_o of the pulse generator.

Fig.9 Load circuitry for switching times.

Dual D-type flip-flop with set and reset;
positive-edge trigger

74HC74; 74HCT74

PACKAGE OUTLINES

DIP14: plastic dual in-line package; 14 leads (300 mil)

SOT27-1

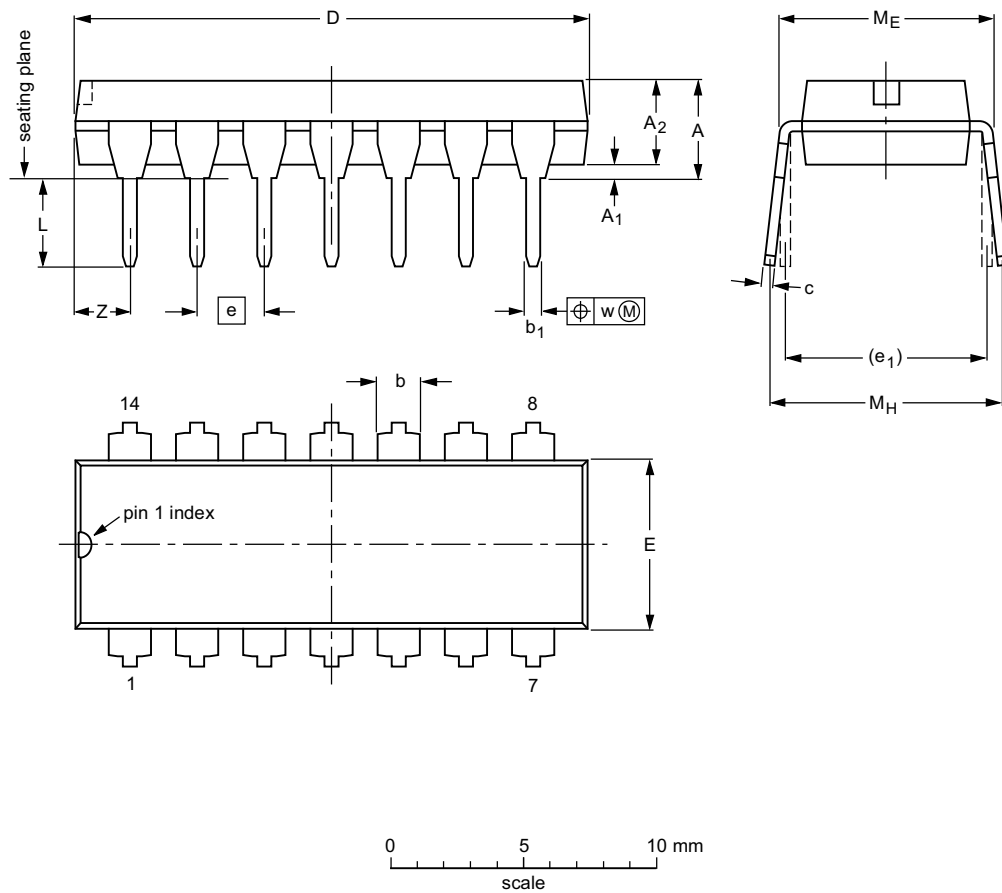

DIMENSIONS (inch dimensions are derived from the original mm dimensions)

UNIT	A max.	A ₁ min.	A ₂ max.	b	b ₁	c	D ⁽¹⁾	E ⁽¹⁾	e	e ₁	L	M _E	M _H	w	z ⁽¹⁾ max.
mm	4.2	0.51	3.2	1.73 1.13	0.53 0.38	0.36 0.23	19.50 18.55	6.48 6.20	2.54	7.62	3.60 3.05	8.25 7.80	10.0 8.3	0.254	2.2
inches	0.17	0.02	0.13	0.068 0.044	0.021 0.015	0.014 0.009	0.77 0.73	0.26 0.24	0.1	0.3	0.14 0.12	0.32 0.31	0.39 0.33	0.01	0.087

Note

1. Plastic or metal protrusions of 0.25 mm (0.01 inch) maximum per side are not included.

OUTLINE VERSION	REFERENCES			EUROPEAN PROJECTION	ISSUE DATE
	IEC	JEDEC	JEITA		
SOT27-1	050G04	MO-001	SC-501-14		99-12-27 03-02-13

Dual D-type flip-flop with set and reset;
positive-edge trigger

74HC74; 74HCT74

SO14: plastic small outline package; 14 leads; body width 3.9 mm

SOT108-1

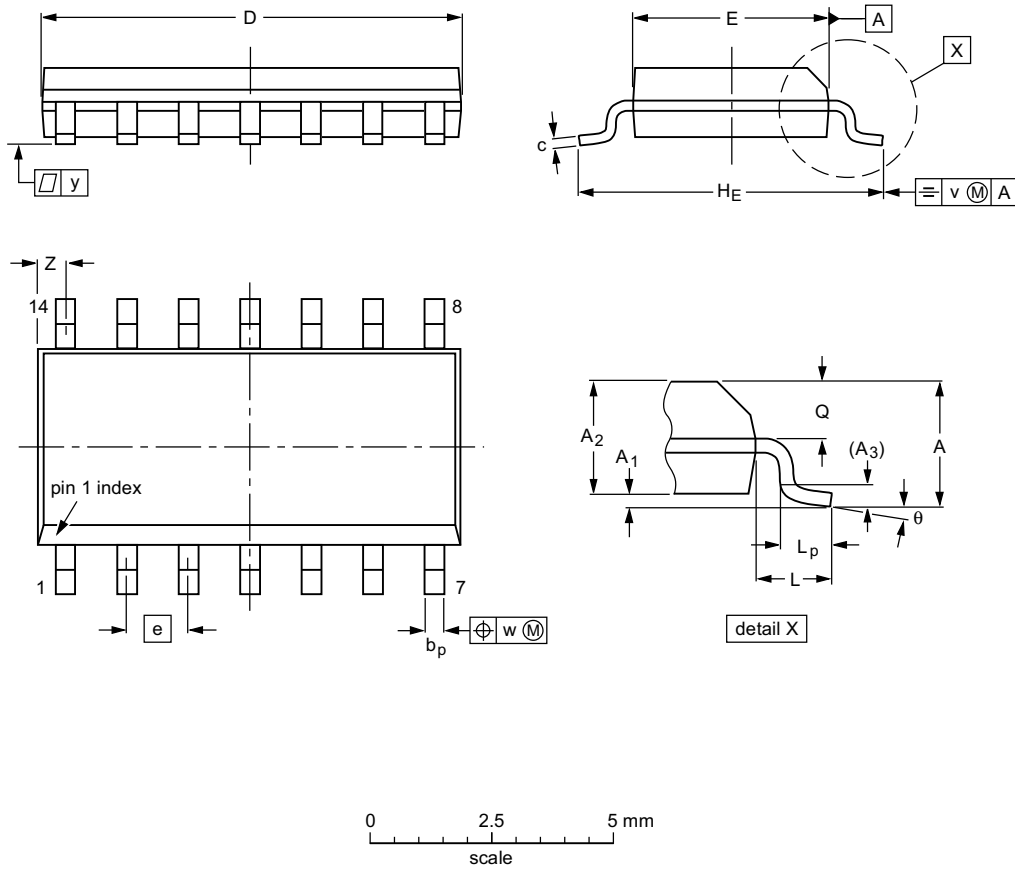

DIMENSIONS (inch dimensions are derived from the original mm dimensions)

UNIT	A max.	A ₁	A ₂	A ₃	b _p	c	D ⁽¹⁾	E ⁽¹⁾	e	H _E	L	L _p	Q	v	w	y	Z ⁽¹⁾	θ
mm	1.75	0.25 0.10	1.45 1.25	0.25	0.49 0.36	0.25 0.19	8.75 8.55	4.0 3.8	1.27	6.2 5.8	1.05	1.0 0.4	0.7 0.6	0.25	0.25	0.1	0.7 0.3	8° 0°
inches	0.069	0.010 0.004	0.057 0.049	0.01	0.019 0.014	0.0100 0.0075	0.35 0.34	0.16 0.15	0.05	0.244 0.228	0.041	0.039 0.016	0.028 0.024	0.01	0.01	0.004	0.028 0.012	

Note

1. Plastic or metal protrusions of 0.15 mm (0.006 inch) maximum per side are not included.

OUTLINE VERSION	REFERENCES			EUROPEAN PROJECTION	ISSUE DATE
	IEC	JEDEC	JEITA		
SOT108-1	076E06	MS-012			99-12-27 03-02-19

Dual D-type flip-flop with set and reset;
positive-edge trigger

74HC74; 74HCT74

SSOP14: plastic shrink small outline package; 14 leads; body width 5.3 mm

SOT337-1

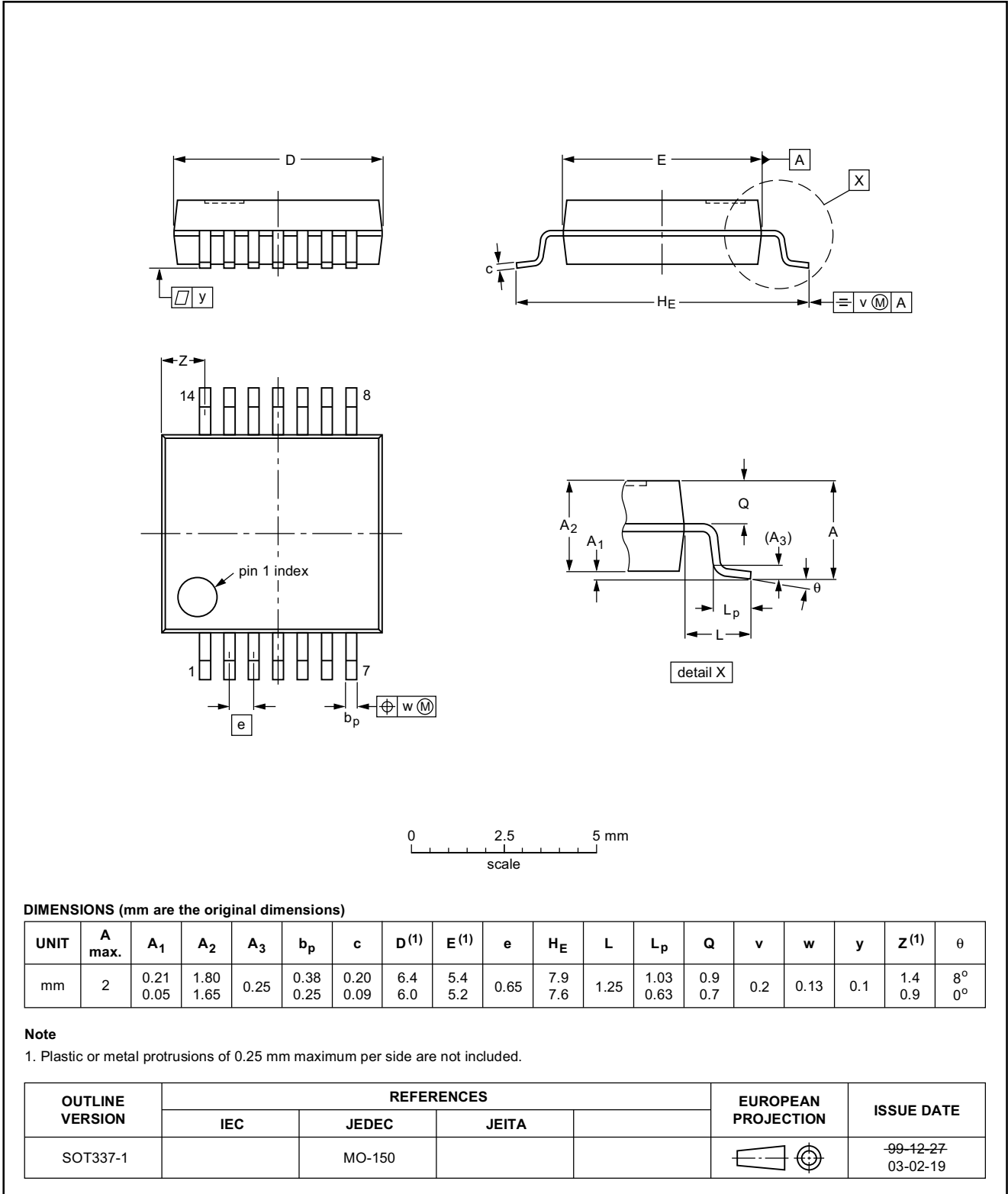

Dual D-type flip-flop with set and reset;
positive-edge trigger

74HC74; 74HCT74

TSSOP14: plastic thin shrink small outline package; 14 leads; body width 4.4 mm

SOT402-1

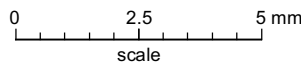
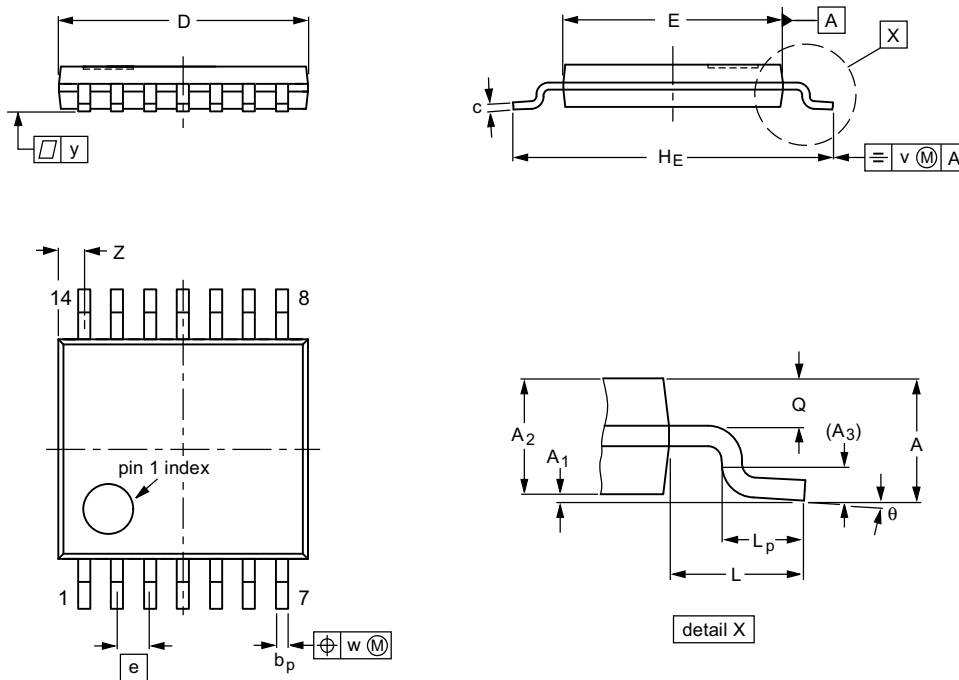

DIMENSIONS (mm are the original dimensions)

UNIT	A max.	A ₁	A ₂	A ₃	b _p	c	D ⁽¹⁾	E ⁽²⁾	e	H _E	L	L _p	Q	v	w	y	z ⁽¹⁾	θ
mm	1.1	0.15 0.05	0.95 0.80	0.25	0.30 0.19	0.2 0.1	5.1 4.9	4.5 4.3	0.65	6.6 6.2	1	0.75 0.50	0.4 0.3	0.2	0.13	0.1	0.72 0.38	8° 0°

Notes

1. Plastic or metal protrusions of 0.15 mm maximum per side are not included.
2. Plastic interlead protrusions of 0.25 mm maximum per side are not included.

OUTLINE VERSION	REFERENCES				EUROPEAN PROJECTION	ISSUE DATE
	IEC	JEDEC	JEITA			
SOT402-1		MO-153				99-12-27 03-02-18

Dual D-type flip-flop with set and reset;
positive-edge trigger

74HC74; 74HCT74

DHVQFN14: plastic dual in-line compatible thermal enhanced very thin quad flat package; no leads;
14 terminals; body 2.5 x 3 x 0.85 mm

SOT762-1

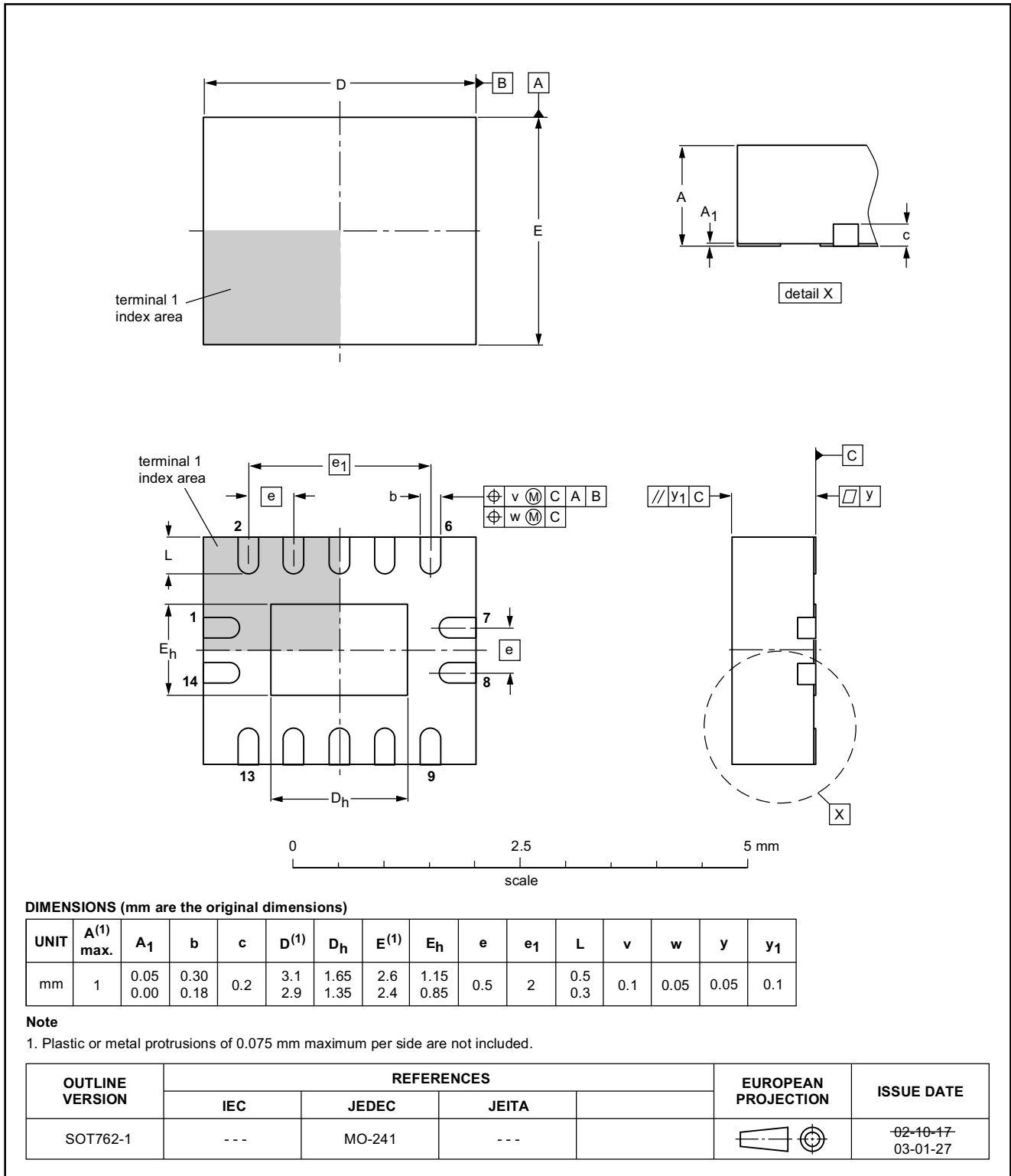

Dual D-type flip-flop with set and reset; positive-edge trigger

74HC74; 74HCT74

DATA SHEET STATUS

LEVEL	DATA SHEET STATUS ⁽¹⁾	PRODUCT STATUS ⁽²⁾⁽³⁾	DEFINITION
I	Objective data	Development	This data sheet contains data from the objective specification for product development. Philips Semiconductors reserves the right to change the specification in any manner without notice.
II	Preliminary data	Qualification	This data sheet contains data from the preliminary specification. Supplementary data will be published at a later date. Philips Semiconductors reserves the right to change the specification without notice, in order to improve the design and supply the best possible product.
III	Product data	Production	This data sheet contains data from the product specification. Philips Semiconductors reserves the right to make changes at any time in order to improve the design, manufacturing and supply. Relevant changes will be communicated via a Customer Product/Process Change Notification (CPCN).

Notes

1. Please consult the most recently issued data sheet before initiating or completing a design.
2. The product status of the device(s) described in this data sheet may have changed since this data sheet was published. The latest information is available on the Internet at URL <http://www.semiconductors.philips.com>.
3. For data sheets describing multiple type numbers, the highest-level product status determines the data sheet status.

DEFINITIONS

Short-form specification — The data in a short-form specification is extracted from a full data sheet with the same type number and title. For detailed information see the relevant data sheet or data handbook.

Limiting values definition — Limiting values given are in accordance with the Absolute Maximum Rating System (IEC 60134). Stress above one or more of the limiting values may cause permanent damage to the device. These are stress ratings only and operation of the device at these or at any other conditions above those given in the Characteristics sections of the specification is not implied. Exposure to limiting values for extended periods may affect device reliability.

Application information — Applications that are described herein for any of these products are for illustrative purposes only. Philips Semiconductors make no representation or warranty that such applications will be suitable for the specified use without further testing or modification.

DISCLAIMERS

Life support applications — These products are not designed for use in life support appliances, devices, or systems where malfunction of these products can reasonably be expected to result in personal injury. Philips Semiconductors customers using or selling these products for use in such applications do so at their own risk and agree to fully indemnify Philips Semiconductors for any damages resulting from such application.

Right to make changes — Philips Semiconductors reserves the right to make changes in the products - including circuits, standard cells, and/or software - described or contained herein in order to improve design and/or performance. When the product is in full production (status 'Production'), relevant changes will be communicated via a Customer Product/Process Change Notification (CPCN). Philips Semiconductors assumes no responsibility or liability for the use of any of these products, conveys no licence or title under any patent, copyright, or mask work right to these products, and makes no representations or warranties that these products are free from patent, copyright, or mask work right infringement, unless otherwise specified.

Philips Semiconductors – a worldwide company

Contact information

For additional information please visit <http://www.semiconductors.philips.com>. Fax: **+31 40 27 24825**

For sales offices addresses send e-mail to: sales.addresses@www.semiconductors.philips.com.

© Koninklijke Philips Electronics N.V. 2003

SCA75

All rights are reserved. Reproduction in whole or in part is prohibited without the prior written consent of the copyright owner.

The information presented in this document does not form part of any quotation or contract, is believed to be accurate and reliable and may be changed without notice. No liability will be accepted by the publisher for any consequence of its use. Publication thereof does not convey nor imply any license under patent- or other industrial or intellectual property rights.

Printed in The Netherlands

613508/03/pp22

Date of release: 2003 Jul 10

Document order number: 9397 750 11259

Let's make things better.

**Philips
Semiconductors**



PHILIPS