

74HC4060; 74HCT4060

14-stage binary ripple counter with oscillator

Rev. 03 — 14 July 2008

Product data sheet

1. General description

The 74HC4060; 74HCT4060 are high-speed Si-gate CMOS device and is pin compatible with the HEF4060.

The 74HC4060; 74HCT4060 are 14-stage ripple-carry counter/dividers and oscillators with three oscillator terminals (RS, RTC and CTC), ten buffered outputs (Q3 to Q9 and Q11 to Q13) and an overriding asynchronous master reset (MR). The oscillator configuration allows design of either RC or crystal oscillator circuits. The oscillator may be replaced by an external clock signal at input RS. In this case keep the other oscillator pins (RTC and CTC) floating. The counter advances on the negative-going transition of RS. A HIGH level on MR resets the counter (Q3 to Q9 and Q11 to Q13 = LOW), independent of other input conditions. In the HCT version, the MR input is TTL compatible, but the RS input has CMOS input switching levels and can be driven by a TTL output by using a pull-up resistor to V_{CC} .

2. Features

- All active components on chip
- RC or crystal oscillator configuration
- Complies with JEDEC standard no. 7 A
- ESD protection:
 - ◆ HBM JESD22-A114E exceeds 2000 V
 - ◆ MM JESD22-A115-A exceeds 200 V
- Multiple package options
- Specified from $-40\text{ }^{\circ}\text{C}$ to $+85\text{ }^{\circ}\text{C}$ and from $-40\text{ }^{\circ}\text{C}$ to $+125\text{ }^{\circ}\text{C}$

3. Applications

- Control counters
- Timers
- Frequency dividers
- Time-delay circuits

4. Ordering information

Table 1. Ordering information

Type number	Package			
	Temperature range	Name	Description	Version
74HC4060N 74HCT4060N	-40 °C to +125 °C	DIP16	plastic dual in-line package; 16 leads (300 mil)	SOT38-4
74HC4060D 74HCT4060D	-40 °C to +125 °C	SO16	plastic small outline package; 16 leads; body width 3.9 mm	SOT109-1
74HC4060DB 74HCT4060DB	-40 °C to +125 °C	SSOP16	plastic shrink small outline package; 16 leads; body width 5.3 mm	SOT338-1
74HC4060PW	-40 °C to +125 °C	TSSOP16	plastic thin shrink small outline package; 16 leads; body width 4.4 mm	SOT403-1
74HC4060BQ 74HCT4060BQ	-40 °C to +125 °C	DHVQFN16	plastic dual in-line compatible thermal-enhanced very thin quad flat package; no leads; 16 terminals; body 2.5 × 3.5 × 0.85 mm	SOT763-1

5. Functional diagram

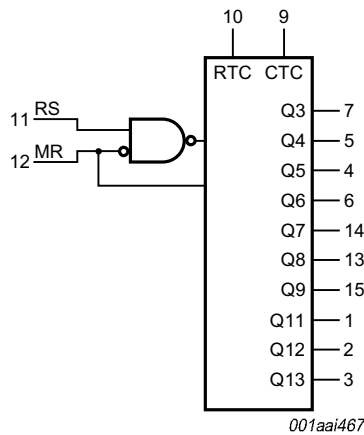

Fig 1. Logic symbol

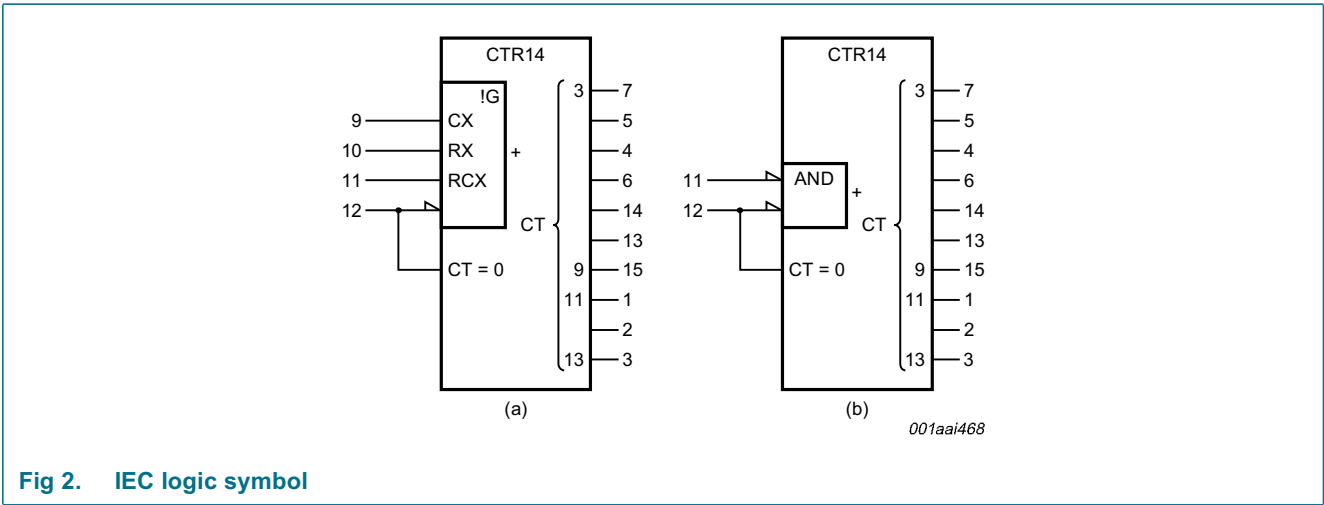

Fig 2. IEC logic symbol

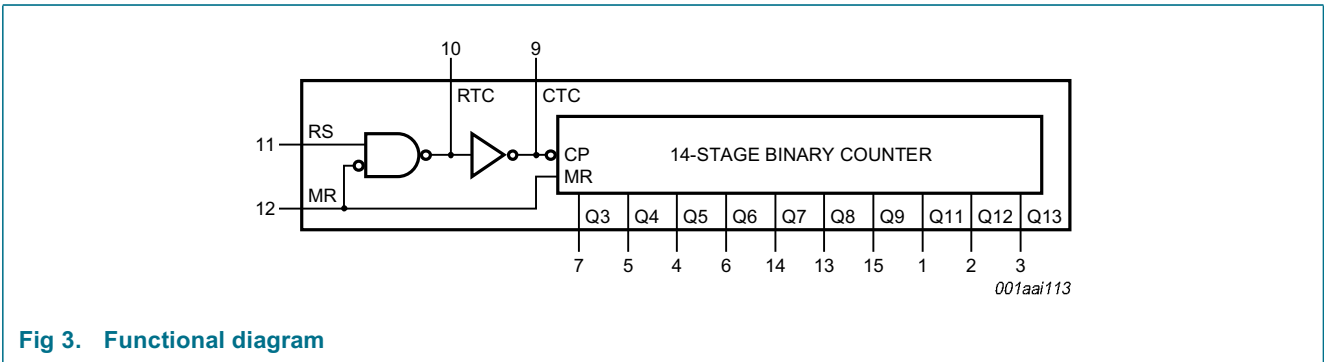

Fig 3. Functional diagram

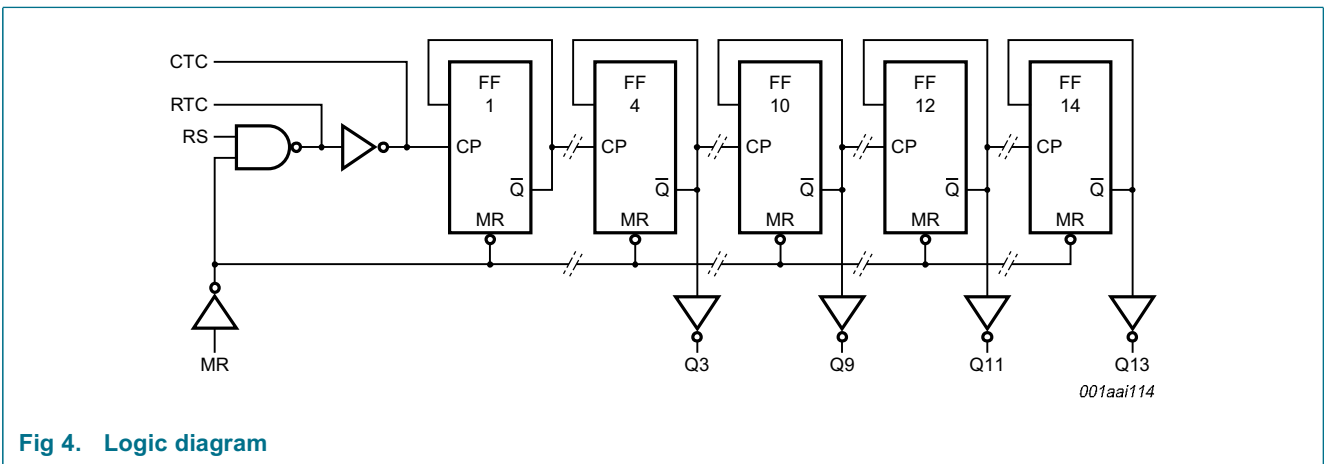
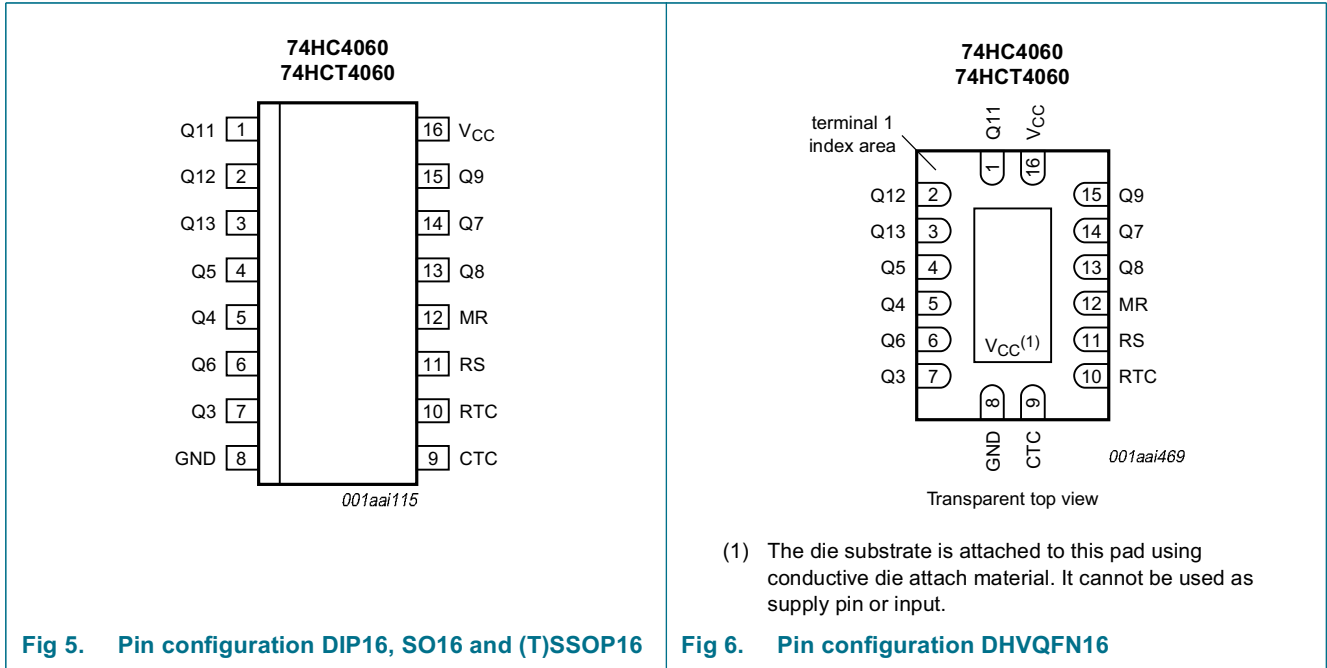

Fig 4. Logic diagram

6. Pinning information

6.1 Pinning



6.2 Pin description

Table 2. Pin description

Symbol	Pin	Description
Q11 to Q13	1, 2, 3	counter output
Q3 to Q9	7, 5, 4, 6, 14, 13, 15	counter output
GND	8	ground (0 V)
CTC	9	external capacitor connection
RTC	10	external resistor connection
RS	11	clock input /oscillator pin
MR	12	master reset input (active HIGH)
V _{CC}	16	supply voltage

7. Functional description

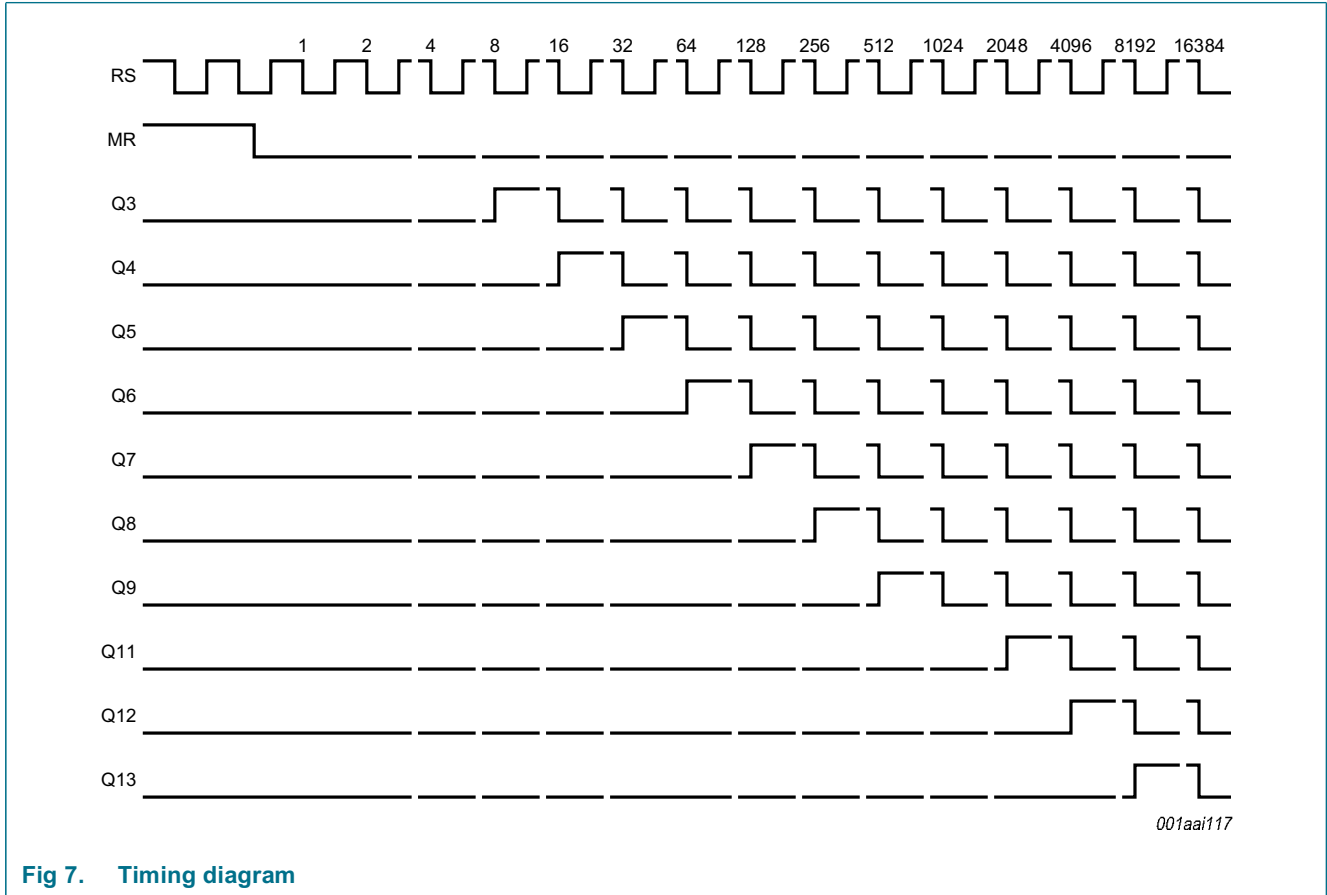

Fig 7. Timing diagram

8. Limiting values

Table 3. Limiting values

In accordance with the Absolute Maximum Rating System (IEC 60134). Voltages are referenced to GND (ground = 0 V).

Symbol	Parameter	Conditions	Min	Max	Unit
V_{CC}	supply voltage		-0.5	+7	V
I_{IK}	input clamping current	$V_I < -0.5\text{ V}$ or $V_I > V_{CC} + 0.5\text{ V}$	[1] -	±20	mA
I_{OK}	output clamping current	$V_O < -0.5\text{ V}$ or $V_O > V_{CC} + 0.5\text{ V}$	[1] -	±20	mA
I_O	output current	$-0.5\text{ V} < V_O < V_{CC} + 0.5\text{ V}$	-	±25	mA
I_{CC}	supply current		-	50	mA
I_{GND}	ground current		-50	-	mA
T_{stg}	storage temperature		-65	+150	°C

Table 3. Limiting values ...continued

In accordance with the Absolute Maximum Rating System (IEC 60134). Voltages are referenced to GND (ground = 0 V).

Symbol	Parameter	Conditions	Min	Max	Unit	
P _{tot}	total power dissipation	T _{amb} = -40 °C to +125 °C				
		DIP16 package	[2]	-	750	mW
		SO16 package	[3]	-	500	mW
		(T)SSOP16 package	[4]	-	500	mW
		DHVQFN16 package	[5]	-	500	mW

[1] The input and output voltage ratings may be exceeded if the input and output current ratings are observed.

[2] P_{tot} derates linearly with 12 mW/K above 70 °C.

[3] P_{tot} derates linearly with 8 mW/K above 70 °C.

[4] P_{tot} derates linearly with 5.5 mW/K above 60 °C.

[5] P_{tot} derates linearly with 4.5 mW/K above 60 °C.

9. Recommended operating conditions

Table 4. Recommended operating conditions

Voltages are referenced to GND (ground = 0 V)

Symbol	Parameter	Conditions	74HC4060			74HCT4060			Unit
			Min	Typ	Max	Min	Typ	Max	
V _{CC}	supply voltage		2.0	5.0	6.0	4.5	5.0	5.5	V
V _I	input voltage		0	-	V _{CC}	0	-	V _{CC}	V
V _O	output voltage		0	-	V _{CC}	0	-	V _{CC}	V
T _{amb}	ambient temperature		-40	-	+125	-40	-	+125	°C
Δt/ΔV	input transition rise and fall rate	V _{CC} = 2.0 V	-	-	625	-	-	-	ns/V
		V _{CC} = 4.5 V	-	1.67	139	-	1.67	139	ns/V
		V _{CC} = 6.0 V	-	-	83	-	-	-	ns/V

10. Static characteristics

Table 5. Static characteristics

At recommended operating conditions; voltages are referenced to GND (ground = 0 V).

Symbol	Parameter	Conditions	25 °C			-40 °C to +85 °C		-40 °C to +125 °C		Unit	
			Min	Typ	Max	Min	Max	Min	Max		
74HC4060											
V _{IH}	HIGH-level input voltage	MR input									
		V _{CC} = 2.0 V	1.5	1.3	-	1.5	-	1.5	-	V	
		V _{CC} = 4.5 V	3.15	2.4	-	3.15	-	3.15	-	V	
		V _{CC} = 6.0 V	4.2	3.1	-	4.2	-	4.2	-	V	
		RS input									
		V _{CC} = 2.0 V	1.7	-	-	1.7	-	1.7	-	V	
V _{CC} = 4.5 V	3.6	-	-	3.6	-	3.6	-	V			
V _{CC} = 6.0 V	4.8	-	-	4.8	-	4.8	-	V			

Table 5. Static characteristics ...continued

At recommended operating conditions; voltages are referenced to GND (ground = 0 V).

Symbol	Parameter	Conditions	25 °C			-40 °C to +85 °C		-40 °C to +125 °C		Unit
			Min	Typ	Max	Min	Max	Min	Max	
V _{IL}	LOW-level input voltage	MR input								
		V _{CC} = 2.0 V	-	0.8	0.5	-	0.5	-	0.5	V
		V _{CC} = 4.5 V	-	2.1	1.35	-	1.35	-	1.35	V
		V _{CC} = 6.0 V	-	2.8	1.8	-	1.8	-	1.8	V
		RS input								
		V _{CC} = 2.0 V	-	-	0.3	-	0.3	-	0.3	V
		V _{CC} = 4.5 V	-	-	0.9	-	0.9	-	0.9	V
		V _{CC} = 6.0 V	-	-	1.2	-	1.2	-	1.2	V
		V _{OH}	HIGH-level output voltage	RTC output; RS = MR = GND						
I _O = -20 µA; V _{CC} = 2.0 V	1.9			2.0	-	1.9	-	1.9	-	V
I _O = -20 µA; V _{CC} = 4.5 V	4.4			4.5	-	4.4	-	4.4	-	V
I _O = -20 µA; V _{CC} = 6.0 V	5.9			6.0	-	5.9	-	5.9	-	V
I _O = -2.6 mA; V _{CC} = 4.5 V	3.98			-	-	3.84	-	3.7	-	V
I _O = -3.3 mA; V _{CC} = 6.0 V	5.48			-	-	5.34	-	5.2	-	V
RTC output; RS = MR = V _{CC}										
I _O = -20 µA; V _{CC} = 2.0 V	1.9			2.0	-	1.9	-	1.9	-	V
I _O = -20 µA; V _{CC} = 4.5 V	4.4			4.5	-	4.4	-	4.4	-	V
I _O = -20 µA; V _{CC} = 6.0 V	5.9			6.0	-	5.9	-	5.9	-	V
I _O = -0.65 mA; V _{CC} = 4.5 V	3.98			-	-	3.84	-	3.7	-	V
I _O = -0.85 mA; V _{CC} = 6.0 V	5.48			-	-	5.34	-	5.2	-	V
CTC output; RS = V _{IH} ; MR = V _{IL}										
I _O = -3.2 mA; V _{CC} = 4.5 V	3.98			-	-	3.84	-	3.7	-	V
I _O = -4.2 mA; V _{CC} = 6.0 V	5.48			-	-	5.34	-	5.2	-	V
V _I = V _{IH} or V _{IL} ; except RTC output										
I _O = -20 µA; V _{CC} = 2.0 V	1.9			2.0	-	1.9	-	1.9	-	V
I _O = -20 µA; V _{CC} = 4.5 V	4.4			4.5	-	4.4	-	4.4	-	V
I _O = -20 µA; V _{CC} = 6.0 V	5.9			6.0	-	5.9	-	5.9	-	V
V _I = V _{IH} or V _{IL} ; except RTC and CTC outputs										
I _O = -4.0 mA; V _{CC} = 4.5 V	3.98			-	-	3.84	-	3.7	-	V
I _O = -5.2 mA; V _{CC} = 6.0 V	5.48	-	-	5.34	-	5.2	-	V		

Table 5. Static characteristics ...continued

At recommended operating conditions; voltages are referenced to GND (ground = 0 V).

Symbol	Parameter	Conditions	25 °C			-40 °C to +85 °C		-40 °C to +125 °C		Unit	
			Min	Typ	Max	Min	Max	Min	Max		
V _{OL}	LOW-level output voltage	RTC output; RS = V _{CC} ; MR = GND									
		I _O = 20 μA; V _{CC} = 2.0 V	-	0	0.1	-	0.1	-	0.1	V	
		I _O = 20 μA; V _{CC} = 4.5 V	-	0	0.1	-	0.1	-	0.1	V	
		I _O = 20 μA; V _{CC} = 6.0 V	-	0	0.1	-	0.1	-	0.1	V	
		I _O = 2.6 mA; V _{CC} = 4.5 V	-	-	0.26	-	0.33	-	0.4	V	
		I _O = 3.3 mA; V _{CC} = 6.0 V	-	-	0.26	-	0.33	-	0.4	V	
		CTC output; RS = V _{IL} ; MR = V _{IH}									
		I _O = 3.2 mA; V _{CC} = 4.5 V	-	-	0.26	-	0.33	-	0.4	V	
		I _O = 4.2 mA; V _{CC} = 6.0 V	-	-	0.26	-	0.33	-	0.4	V	
		V _I = V _{IH} or V _{IL} ; except RTC output									
		I _O = 20 μA; V _{CC} = 2.0 V	-	0	0.1	-	0.1	-	0.1	V	
		I _O = 20 μA; V _{CC} = 4.5 V	-	0	0.1	-	0.1	-	0.1	V	
		I _O = 20 μA; V _{CC} = 6.0 V	-	0	0.1	-	0.1	-	0.1	V	
		V _I = V _{IH} or V _{IL} ; except RTC and CTC outputs									
		I _O = 4.0 mA; V _{CC} = 4.5 V	-	-	0.26	-	0.33	-	0.4	V	
		I _O = 5.2 mA; V _{CC} = 6.0 V	-	-	0.26	-	0.33	-	0.4	V	
I _I	input leakage current	V _I = V _{CC} or GND; V _{CC} = 6.0 V	-	-	±0.1	-	±1.0	-	±1.0	μA	
I _{CC}	supply current	V _I = V _{CC} or GND; I _O = 0 A; V _{CC} = 6.0 V	-	-	8.0	-	80	-	160	μA	
C _I	input capacitance		-	3.5	-	-	-	-	-	pF	
74HCT4060											
V _{IH}	HIGH-level input voltage	MR input; V _{CC} = 4.5 V to 5.5 V	[1]	2.0	-	-	2.0	-	2.0	-	V
V _{IL}	LOW-level input voltage	MR input; V _{CC} = 4.5 V to 5.5 V	[1]	-	-	0.8	-	0.8	-	0.8	V

Table 5. Static characteristics ...continued

At recommended operating conditions; voltages are referenced to GND (ground = 0 V).

Symbol	Parameter	Conditions	25 °C			-40 °C to +85 °C		-40 °C to +125 °C		Unit
			Min	Typ	Max	Min	Max	Min	Max	
V _{OH}	HIGH-level output voltage	RTC output; RS = MR = V _{CC}								
		I _O = -20 μA; V _{CC} = 4.5 V	4.4	4.5	-	4.4	-	4.4	-	V
		I _O = -0.65 mA; V _{CC} = 4.5 V	3.98	-	-	3.84	-	3.7	-	V
		RTC output; RS = MR = GND								
		I _O = -20 μA; V _{CC} = 4.5 V	4.4	4.5	-	4.4	-	4.4	-	V
		I _O = -2.6 mA; V _{CC} = 4.5 V	3.98	-	-	3.84	-	3.7	-	V
		CTC output; RS = V _{IH} ; MR = V _{IL}								
		I _O = -3.2 mA; V _{CC} = 4.5 V	3.98	-	-	3.84	-	3.7	-	V
		V _I = V _{IH} or V _{IL} ; except RTC output								
		I _O = -20 μA; V _{CC} = 4.5 V	4.4	4.5	-	4.4	-	4.4	-	V
V _I = V _{IH} or V _{IL} ; except RTC and CTC outputs										
I _O = -4.0 mA; V _{CC} = 4.5 V	3.98	-	-	3.84	-	3.7	-	V		
V _{OL}	LOW-level output voltage	RTC output; RS = V _{CC} ; MR = GND								
		I _O = 20 μA; V _{CC} = 4.5 V	-	0	0.1	-	0.1	-	0.1	V
		I _O = 2.6 mA; V _{CC} = 4.5 V	-	-	0.26	-	0.33	-	0.4	V
		CTC output; RS = V _{IL} ; MR = V _{IH}								
		I _O = 3.2 mA; V _{CC} = 4.5 V	-	-	0.26	-	0.33	-	0.4	V
		V _I = V _{IH} or V _{IL} ; except RTC output								
		I _O = 20 μA; V _{CC} = 4.5 V	-	0	0.1	-	0.1	-	0.1	V
V _I = V _{IH} or V _{IL} ; except RTC and CTC outputs										
I _O = 4.0 mA; V _{CC} = 4.5 V	-	-	0.26	-	0.33	-	0.4	V		
I _I	input leakage current	V _I = V _{CC} or GND; V _{CC} = 5.5 V	-	-	±0.1	-	±1.0	-	±1.0	μA
I _{CC}	supply current	V _I = V _{CC} or GND; V _{CC} = 5.5 V; I _O = 0 A	-	-	8.0	-	80	-	160	μA
ΔI _{CC}	additional supply current	per input pin; V _I = V _{CC} - 2.1 V; other inputs at V _{CC} or GND; V _{CC} = 4.5 V to 5.5 V; I _O = 0 A	-	40	144	-	180	-	196	μA
C _I	input capacitance		-	3.5	-	-	-	-	-	pF

[1] For HCT4060, only input MR (pin 12) has TTL input switching levels.

11. Dynamic characteristics

Table 6. Dynamic characteristics

$GND = 0\text{ V}$; $C_L = 50\text{ pF}$ unless otherwise specified; for test circuit see [Figure 11](#).

Symbol	Parameter	Conditions	25 °C			-40 °C to +85 °C		-40 °C to +125 °C		Unit
			Min	Typ	Max	Min	Max	Min	Max	
74HC4060										
t_{pd}	propagation delay	RS to Q3; see Figure 8 ^[1]								
		$V_{CC} = 2.0\text{ V}$	-	99	300	-	375	-	450	ns
		$V_{CC} = 4.5\text{ V}$	-	36	60	-	75	-	90	ns
		$V_{CC} = 5.0\text{ V}$; $C_L = 15\text{ pF}$	-	31	-	-	-	-	-	ns
		$V_{CC} = 6.0\text{ V}$	-	29	51	-	64	-	77	ns
		Qn to Qn+1; see Figure 9 ^[2]								
		$V_{CC} = 2.0\text{ V}$	-	22	80	-	100	-	120	ns
		$V_{CC} = 4.5\text{ V}$	-	8	16	-	20	-	24	ns
	$V_{CC} = 5.0\text{ V}$; $C_L = 15\text{ pF}$	-	6	-	-	-	-	-	ns	
	$V_{CC} = 6.0\text{ V}$	-	6	14	-	17	-	20	ns	
t_{PHL}	HIGH to LOW propagation delay	MR to Qn; see Figure 10								
		$V_{CC} = 2.0\text{ V}$	-	55	175	-	220	-	265	ns
		$V_{CC} = 4.5\text{ V}$	-	20	35	-	44	-	53	ns
		$V_{CC} = 5.0\text{ V}$; $C_L = 15\text{ pF}$	-	17	-	-	-	-	-	ns
	$V_{CC} = 6.0\text{ V}$	-	16	30	-	37	-	45	ns	
t_t	transition time	Qn; see Figure 8 ^[3]								
		$V_{CC} = 2.0\text{ V}$	-	19	75	-	95	-	110	ns
		$V_{CC} = 4.5\text{ V}$	-	7	15	-	19	-	22	ns
		$V_{CC} = 6.0\text{ V}$	-	6	13	-	16	-	19	ns
t_W	pulse width	RS (HIGH or LOW); see Figure 8								
		$V_{CC} = 2.0\text{ V}$	80	17	-	100	-	120	-	ns
		$V_{CC} = 4.5\text{ V}$	16	6	-	20	-	24	-	ns
		$V_{CC} = 6.0\text{ V}$	14	5	-	17	-	20	-	ns
		MR (HIGH); see Figure 10								
		$V_{CC} = 2.0\text{ V}$	80	25	-	100	-	120	-	ns
		$V_{CC} = 4.5\text{ V}$	16	9	-	20	-	24	-	ns
		$V_{CC} = 6.0\text{ V}$	14	7	-	17	-	20	-	ns
t_{rec}	recovery time	MR to RS; see Figure 10								
		$V_{CC} = 2.0\text{ V}$	100	28	-	125	-	150	-	ns
		$V_{CC} = 4.5\text{ V}$	20	10	-	25	-	30	-	ns
		$V_{CC} = 6.0\text{ V}$	17	8	-	21	-	26	-	ns

Table 6. Dynamic characteristics ...continued
GND = 0 V; C_L = 50 pF unless otherwise specified; for test circuit see Figure 11.

Symbol	Parameter	Conditions	25 °C			-40 °C to +85 °C		-40 °C to +125 °C		Unit	
			Min	Typ	Max	Min	Max	Min	Max		
f _{max}	maximum frequency	RS; see Figure 8									
		V _{CC} = 2.0 V	6	26	-	4.8	-	4	-	MHz	
		V _{CC} = 4.5 V	30	80	-	24	-	20	-	MHz	
		V _{CC} = 5.0 V; C _L = 15 pF	-	87	-	-	-	-	-	MHz	
		V _{CC} = 6.0 V	35	95	-	28	-	24	-	MHz	
C _{PD}	power dissipation capacitance	V _I = GND to V _{CC} ; V _{CC} = 5 V; f _i = 1 MHz	[4]	-	40	-	-	-	-	pF	
74HCT4060											
t _{pd}	propagation delay	RS to Q3; see Figure 8	[1]								
		V _{CC} = 4.5 V	-	33	66	-	83	-	99	ns	
		V _{CC} = 5.0 V; C _L = 15 pF	-	31	-	-	-	-	-	ns	
		Qn to Qn+1; see Figure 9	[2]								
		V _{CC} = 4.5 V	-	8	16	-	20	-	24	ns	
		V _{CC} = 5.0 V; C _L = 15 pF	-	6	-	-	-	-	ns		
t _{PHL}	HIGH to LOW propagation delay	MR to Qn; see Figure 10									
		V _{CC} = 4.5 V	-	21	44	-	55	-	66	ns	
		V _{CC} = 5.0 V; C _L = 15 pF	-	18	-	-	-	-	ns		
t _t	transition time	Qn; see Figure 8	[3]								
		V _{CC} = 4.5 V	-	7	15	-	19	-	22	ns	
t _W	pulse width	RS (HIGH or LOW); see Figure 8									
		V _{CC} = 4.5 V	16	6	-	20	-	24	-	ns	
		MR (HIGH); see Figure 10									
		V _{CC} = 4.5 V	16	6	-	20	-	24	-	ns	
t _{rec}	recovery time	MR to RS; see Figure 10									
		V _{CC} = 4.5 V	26	13	-	33	-	39	-	ns	
f _{max}	maximum frequency	RS; see Figure 8									
		V _{CC} = 4.5 V	30	80	-	24	-	20	-	MHz	
		V _{CC} = 5.0 V; C _L = 15 pF	-	88	-	-	-	-	-	MHz	

Table 6. Dynamic characteristics ...continued
GND = 0 V; C_L = 50 pF unless otherwise specified; for test circuit see Figure 11.

Symbol	Parameter	Conditions	25 °C			-40 °C to +85 °C		-40 °C to +125 °C		Unit
			Min	Typ	Max	Min	Max	Min	Max	
C _{PD}	power dissipation capacitance	V _I = GND to V _{CC} - 1.5 V; V _{CC} = 5 V; f _i = 1 MHz	-	40	-	-	-	-	-	pF

- [1] t_{pd} is the same as t_{PHL} and t_{PLH}.
- [2] Q_{n+1} is the next Q_n output.
- [3] t_i is the same as t_{THL} and t_{TLH}.
- [4] C_{PD} is used to determine the dynamic power dissipation (P_D in μW):
 $P_D = C_{PD} \times V_{CC}^2 \times f_i \times N + \sum(C_L \times V_{CC}^2 \times f_o)$ where:
 f_i = input frequency in MHz;
 f_o = output frequency in MHz;
 C_L = output load capacitance in pF;
 V_{CC} = supply voltage in V;
 N = number of inputs switching;
 $\sum(C_L \times V_{CC}^2 \times f_o)$ = sum of outputs.

12. Waveforms

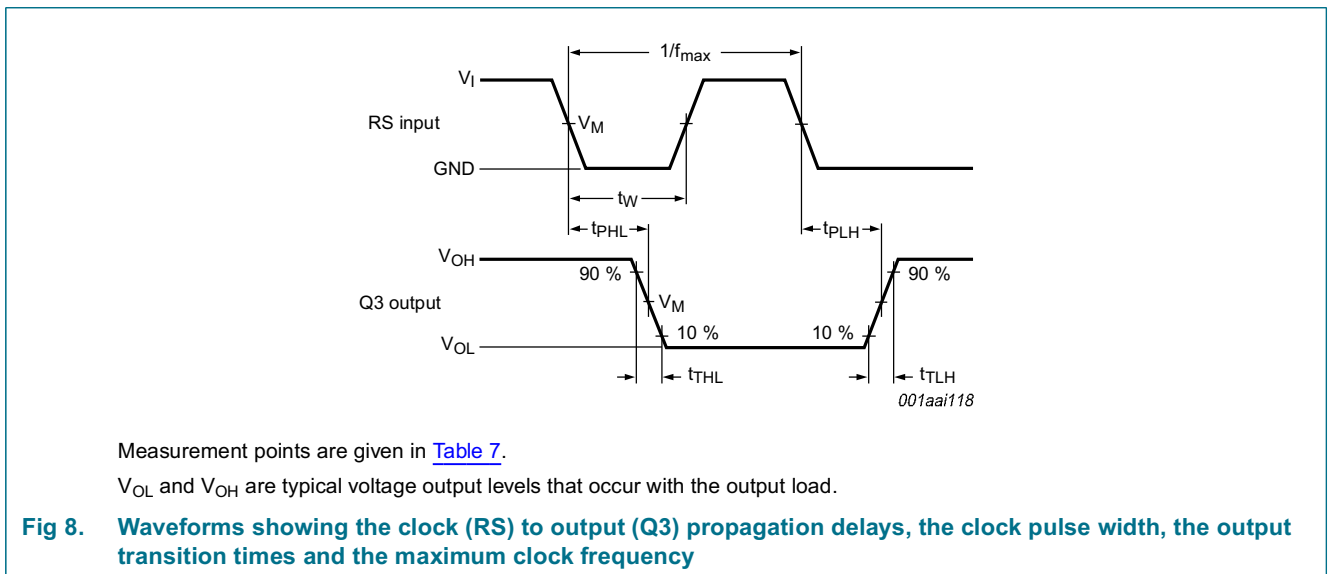

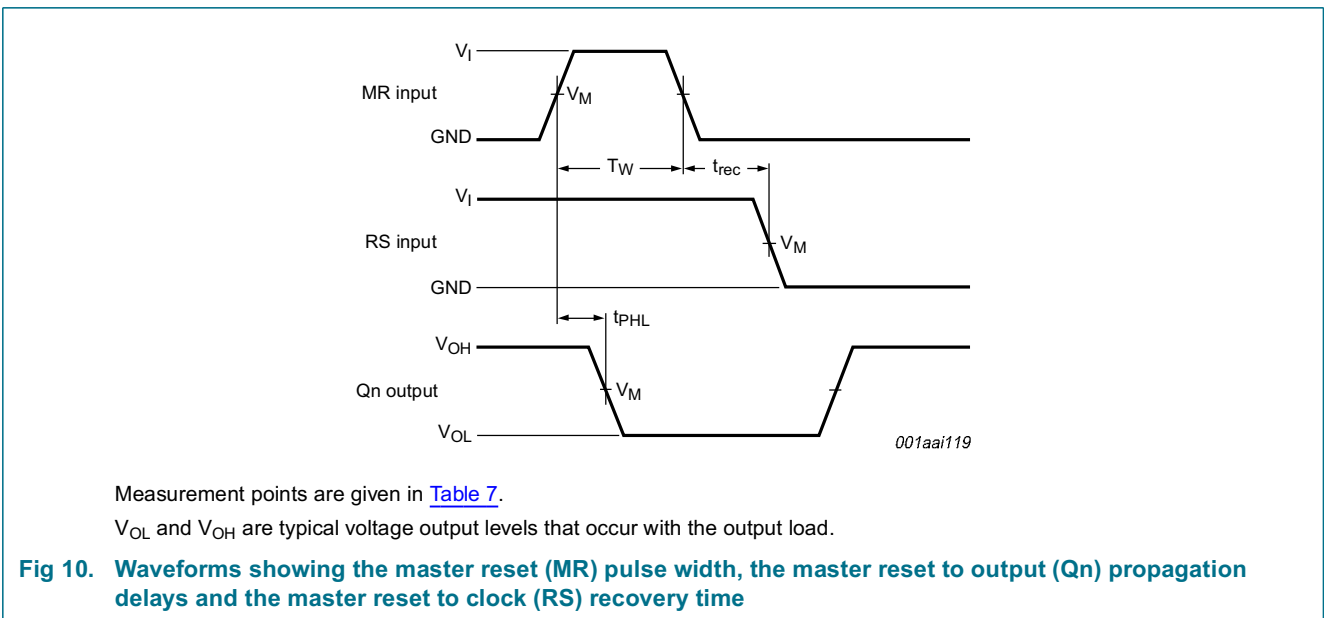
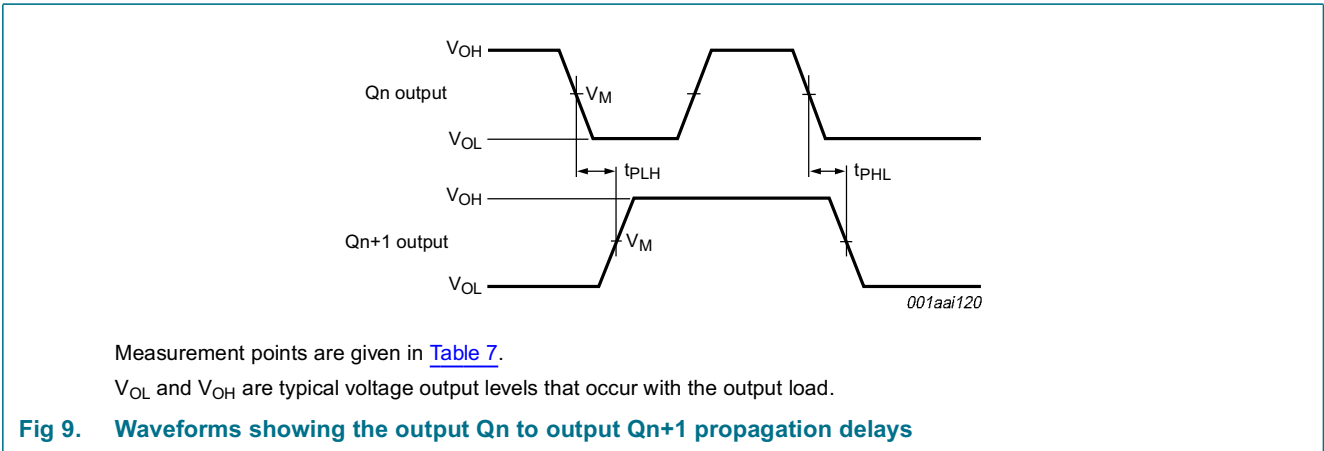
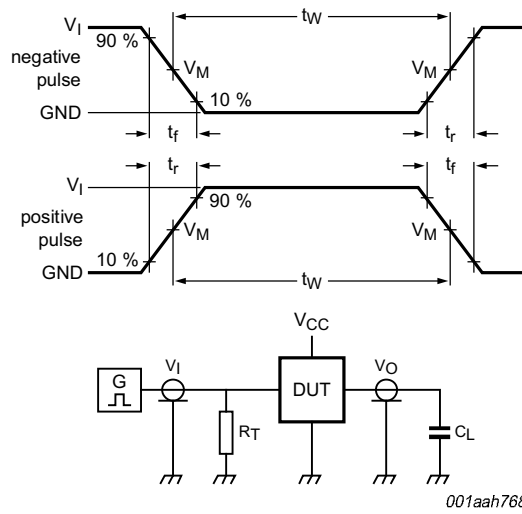

Table 7. Measurement points

Type	Input	Output
	V_M	V_M
74HC4060	$0.5 \times V_{CC}$	$0.5 \times V_{CC}$
74HCT4060	1.3 V	1.3 V



Test data is given in [Table 8](#).

Definitions test circuit:

R_T = Termination resistance should be equal to output impedance Z_o of the pulse generator.

C_L = Load capacitance including jig and probe capacitance.

Fig 11. Test circuit for measuring switching times

Table 8. Test data

Type	Input		Load
	V_I	t_r, t_f	C_L
74HC4060	V_{CC}	6 ns	15 pF, 50 pF
74HCT4060	3 V	6 ns	15 pF, 50 pF

13. RC oscillator

13.1 Timing component limitations

The oscillator frequency is mainly determined by $R_t C_t$, provided $R_2 \approx 2R_t$ and $R_2 C_2 \ll R_t C_t$. The function of R_2 is to minimize the influence of the forward voltage across the input protection diodes on the frequency. The stray capacitance C_2 should be kept as small as possible. In consideration of accuracy, C_t must be larger than the inherent stray capacitance. R_t must be larger than the ON resistance in series with it, which typically is 280 Ω at $V_{CC} = 2.0$ V, 130 Ω at $V_{CC} = 4.5$ V and 100 Ω at $V_{CC} = 6.0$ V.

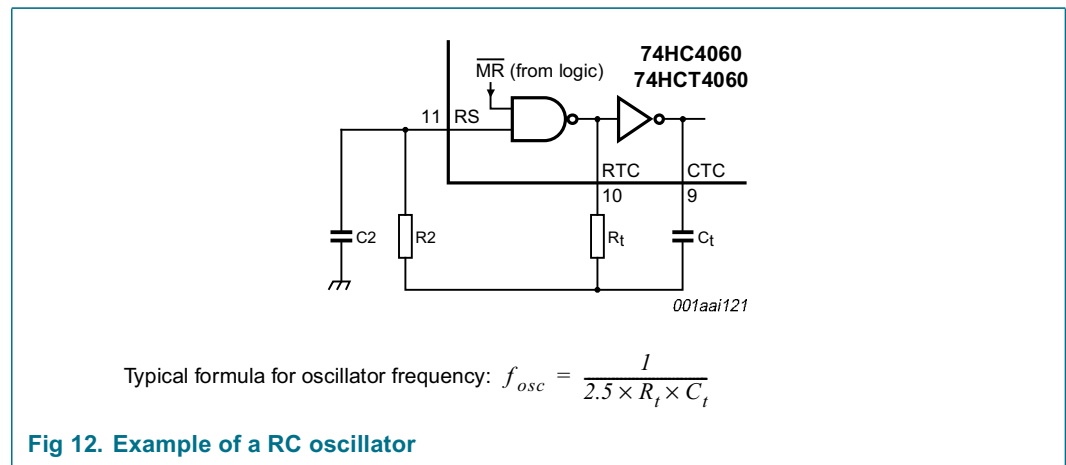

Fig 12. Example of a RC oscillator

The recommended values for these components to maintain agreement with the typical oscillation formula are:

$C_t > 50$ pF, up to any practical value and $10 \text{ k}\Omega < R_t < 1 \text{ M}\Omega$.

In order to avoid start-up problems, $R_t \geq 1 \text{ k}\Omega$.

13.2 Typical crystal oscillator circuit

In [Figure 13](#), R_2 is the power limiting resistor. For starting and maintaining oscillation a minimum transconductance is necessary, so R_2 should not be too large. A practical value for R_2 is 2.2 $\text{k}\Omega$.

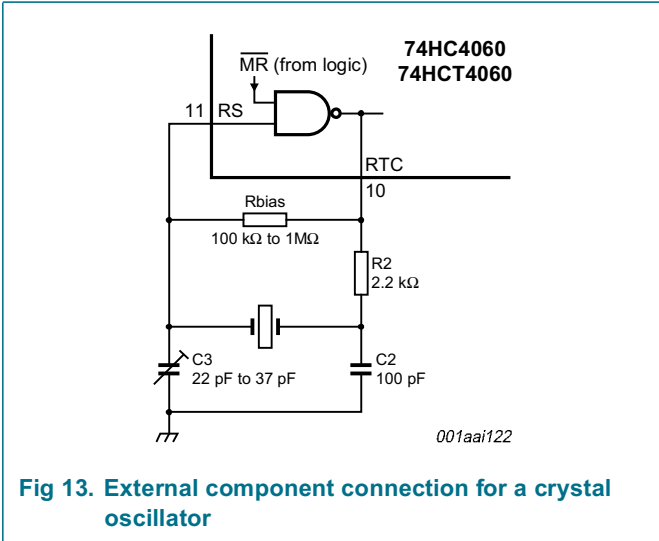

Fig 13. External component connection for a crystal oscillator

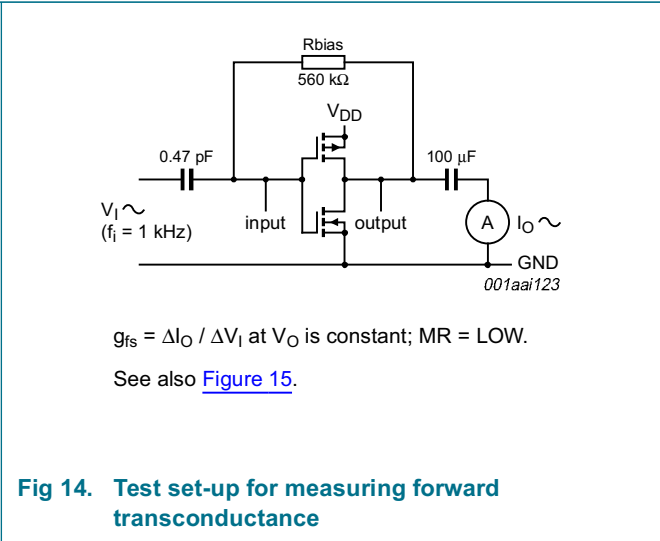

Fig 14. Test set-up for measuring forward transconductance

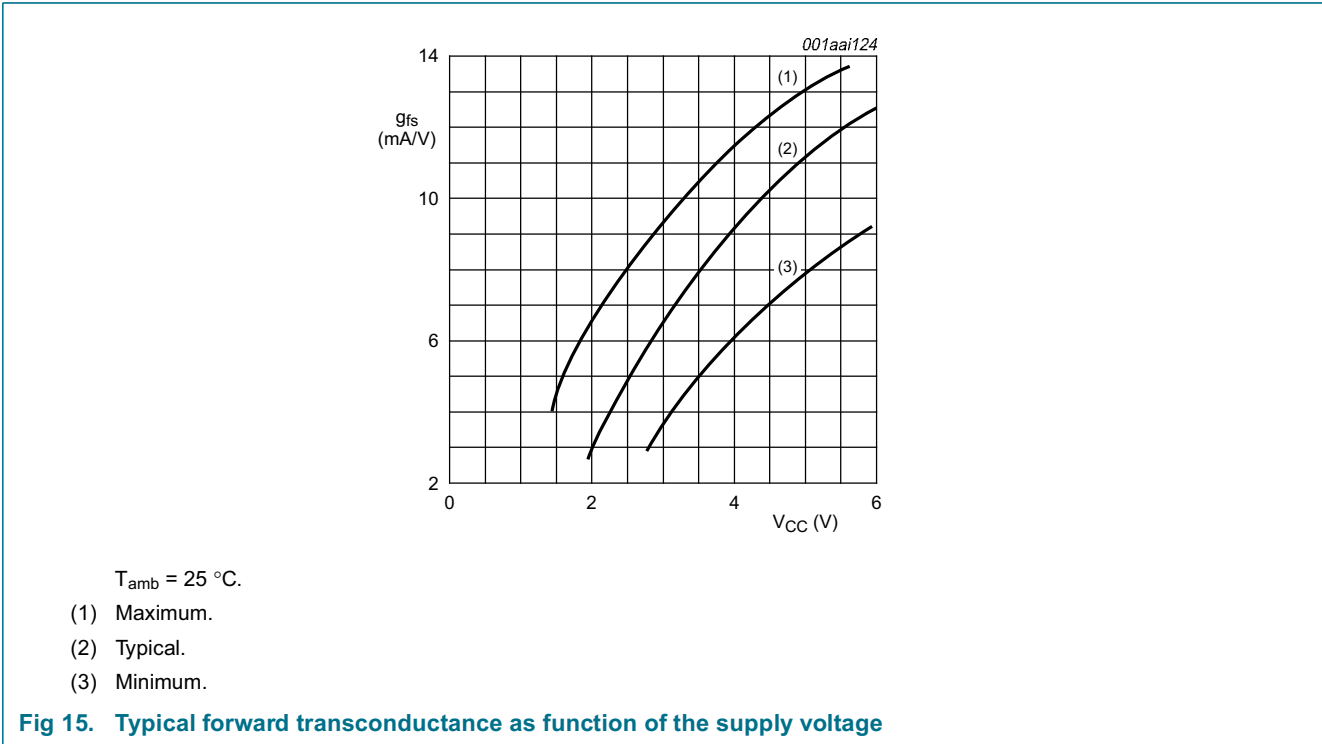
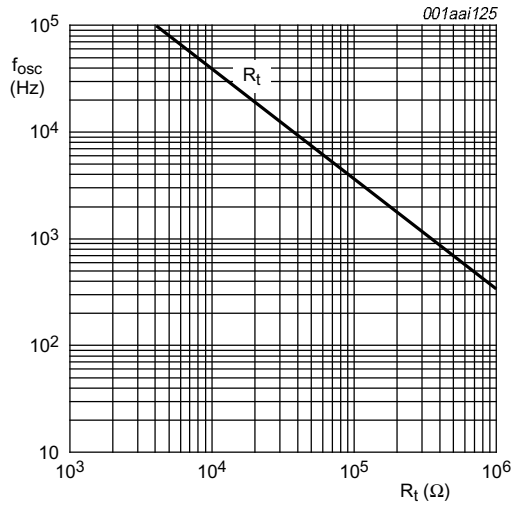
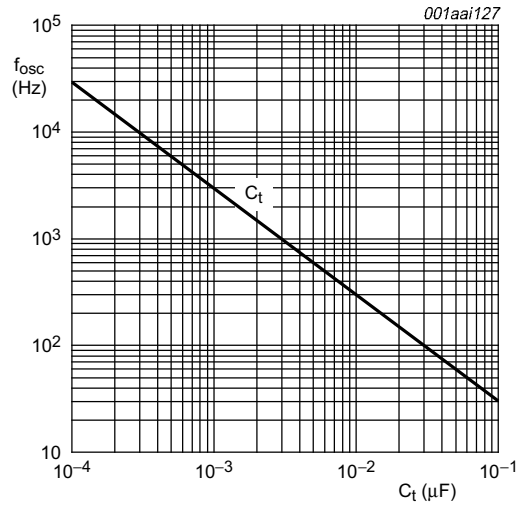

Fig 15. Typical forward transconductance as function of the supply voltage



$V_{CC} = 2.0\text{ V to }6.0\text{ V}; T_{amb} = 25\text{ }^{\circ}\text{C}.$
 For R_t curve: $C_t = 1\text{ nF}; R_2 = 2 \times R_t.$

Fig 16. RC oscillator frequency as a function of R_t



$V_{CC} = 2.0\text{ V to }6.0\text{ V}; T_{amb} = 25\text{ }^{\circ}\text{C}.$
 For C_t curve: $R_t = 100\text{ k}\Omega; R_2 = 200\text{ k}\Omega.$

Fig 17. RC oscillator frequency as a function of C_t

14. Package outline

DIP16: plastic dual in-line package; 16 leads (300 mil)

SOT38-4

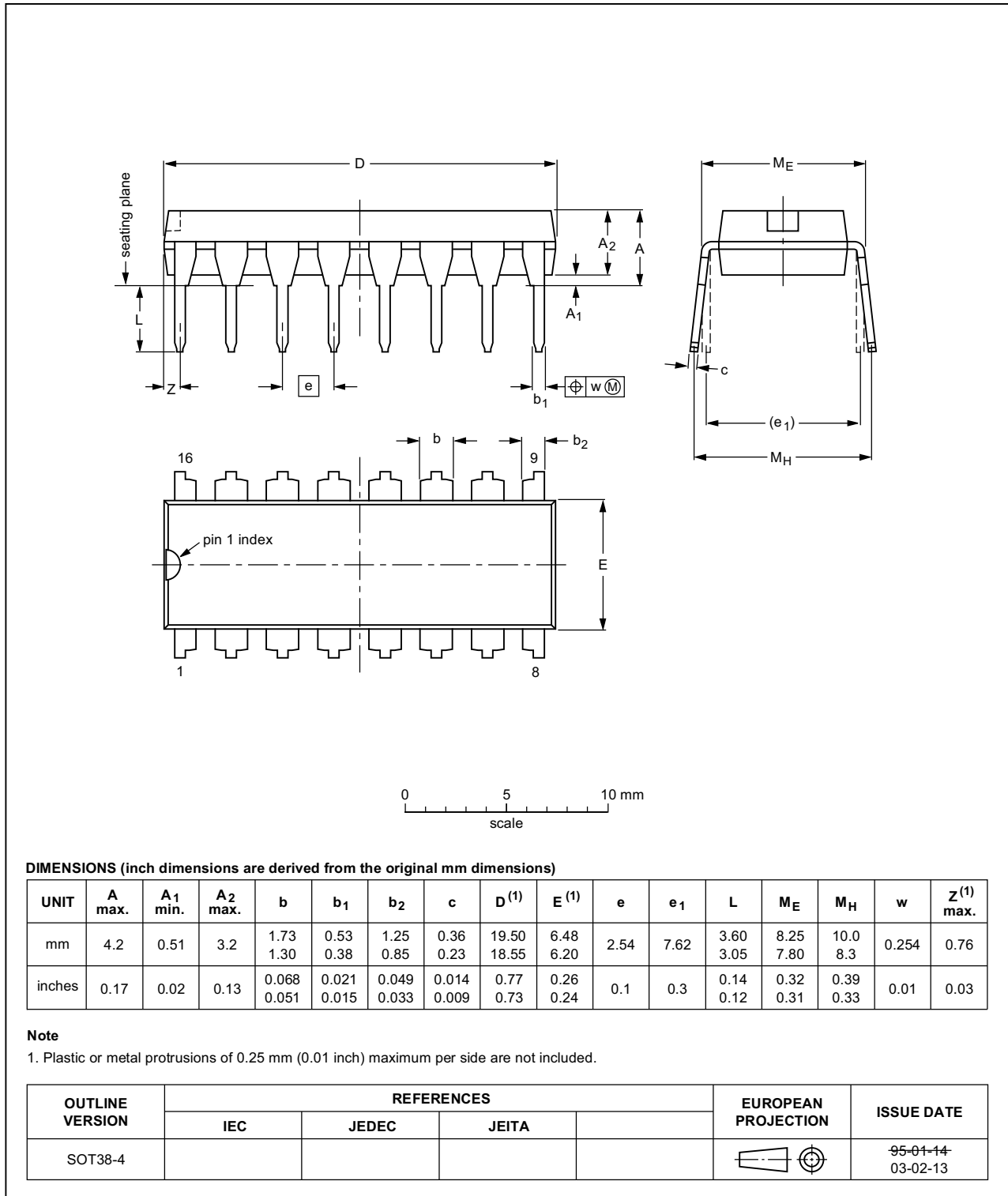

Fig 18. Package outline SOT38-4 (DIP16)

SO16: plastic small outline package; 16 leads; body width 3.9 mm

SOT109-1

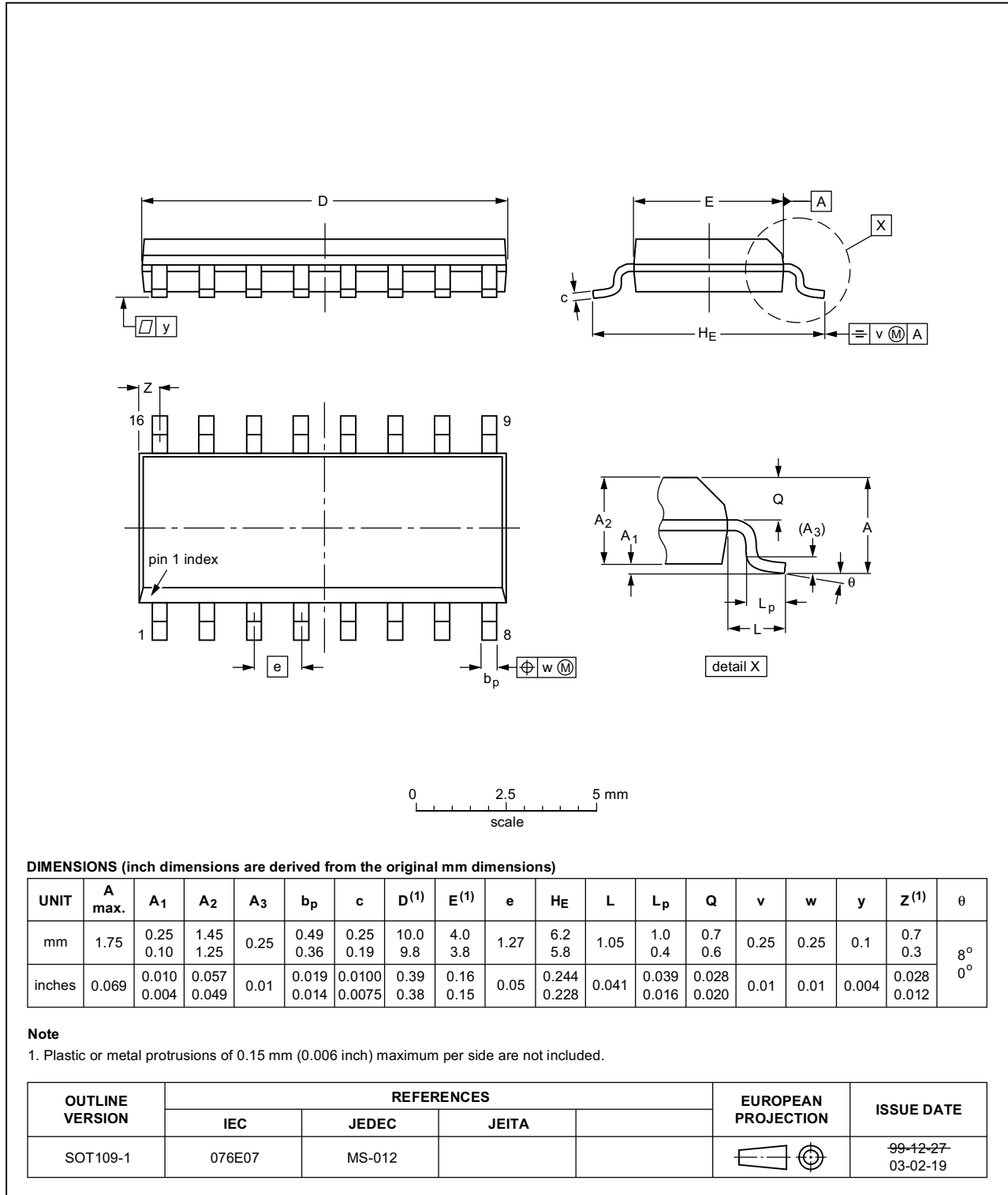

Fig 19. Package outline SOT109-1 (SO16)

SSOP16: plastic shrink small outline package; 16 leads; body width 5.3 mm

SOT338-1

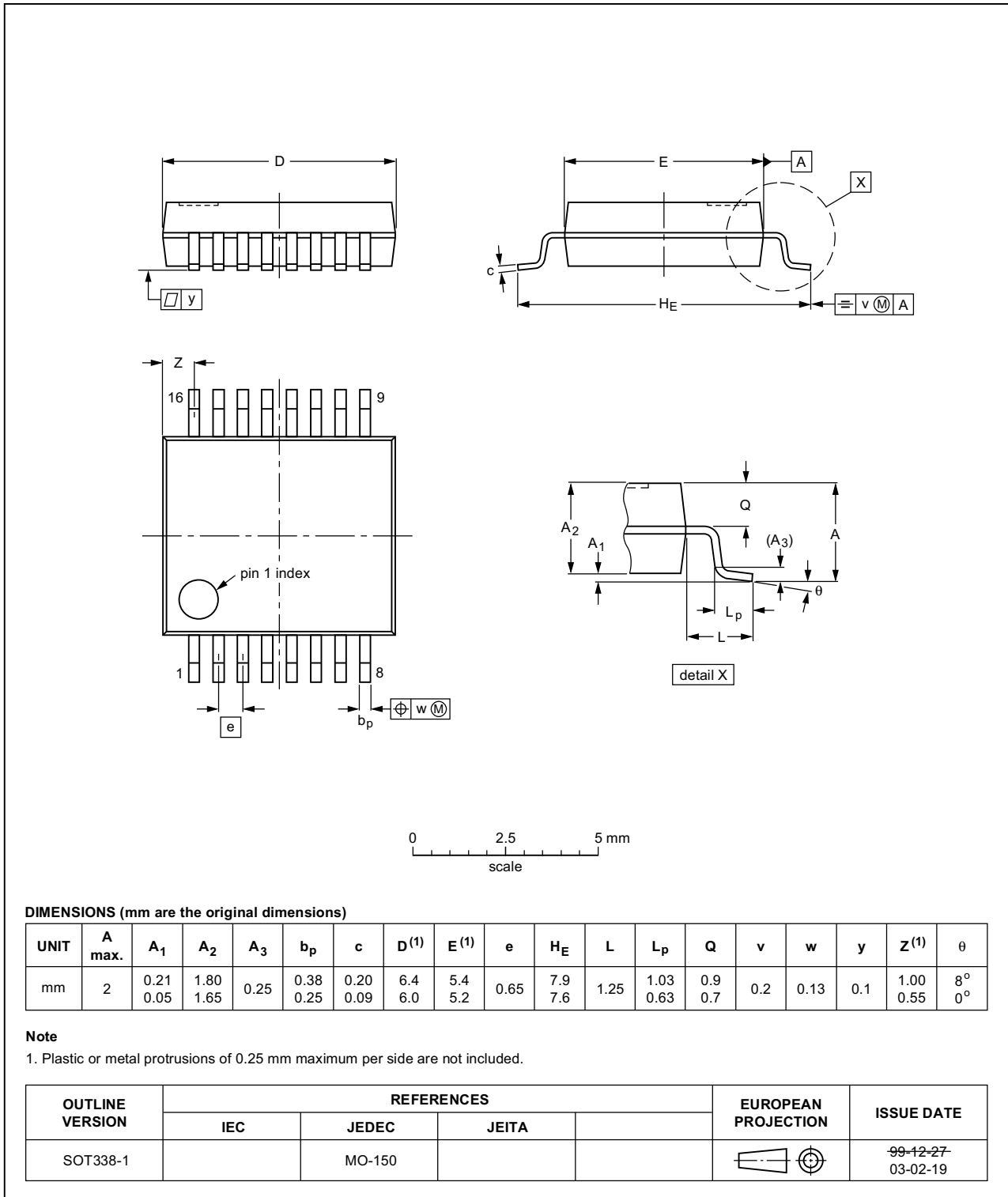

Fig 20. Package outline SOT338-1 (SSOP16)

TSSOP16: plastic thin shrink small outline package; 16 leads; body width 4.4 mm

SOT403-1

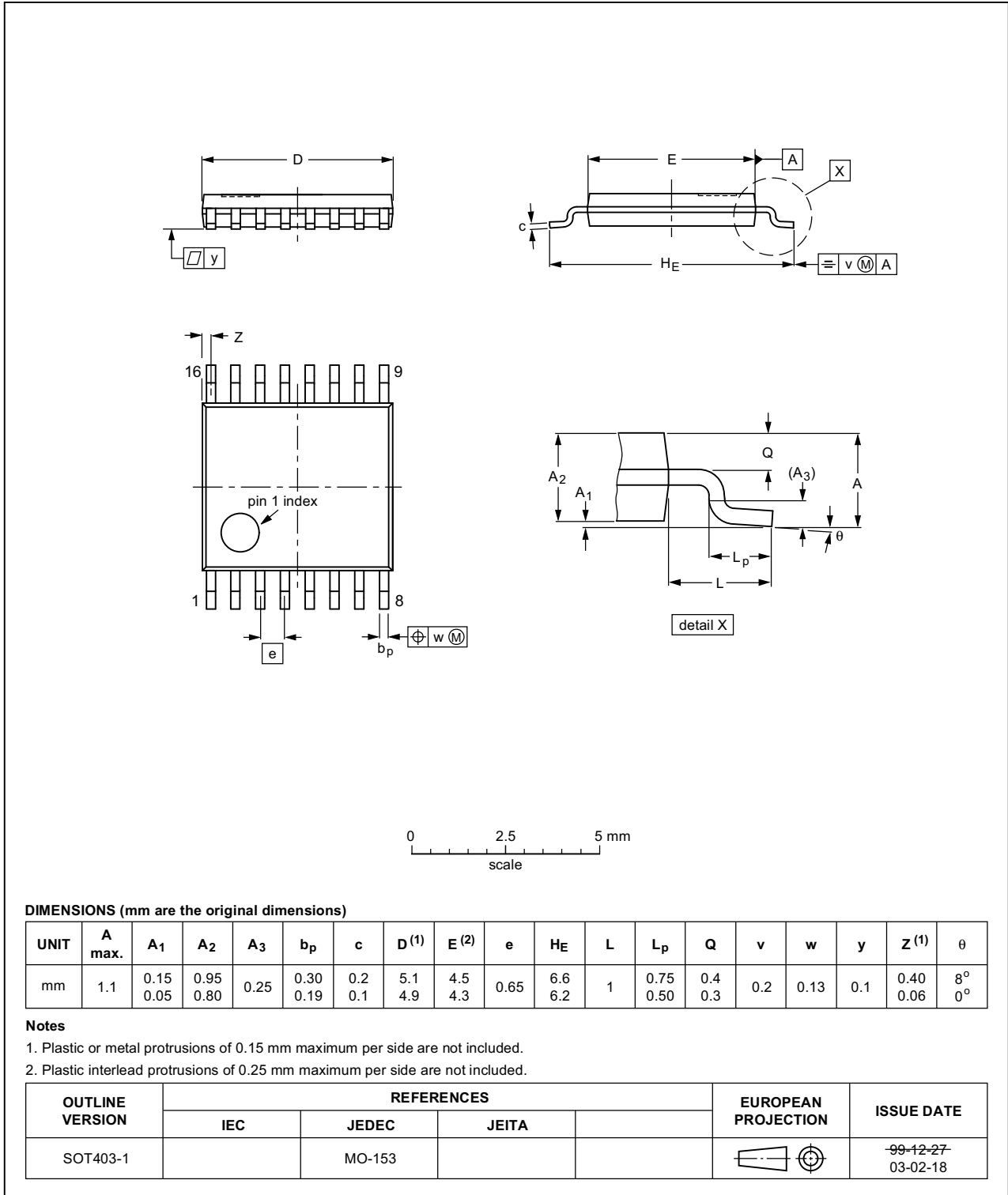

Fig 21. Package outline SOT403-1 (TSSOP16)

DHVQFN16: plastic dual in-line compatible thermal enhanced very thin quad flat package; no leads; 16 terminals; body 2.5 x 3.5 x 0.85 mm

SOT763-1

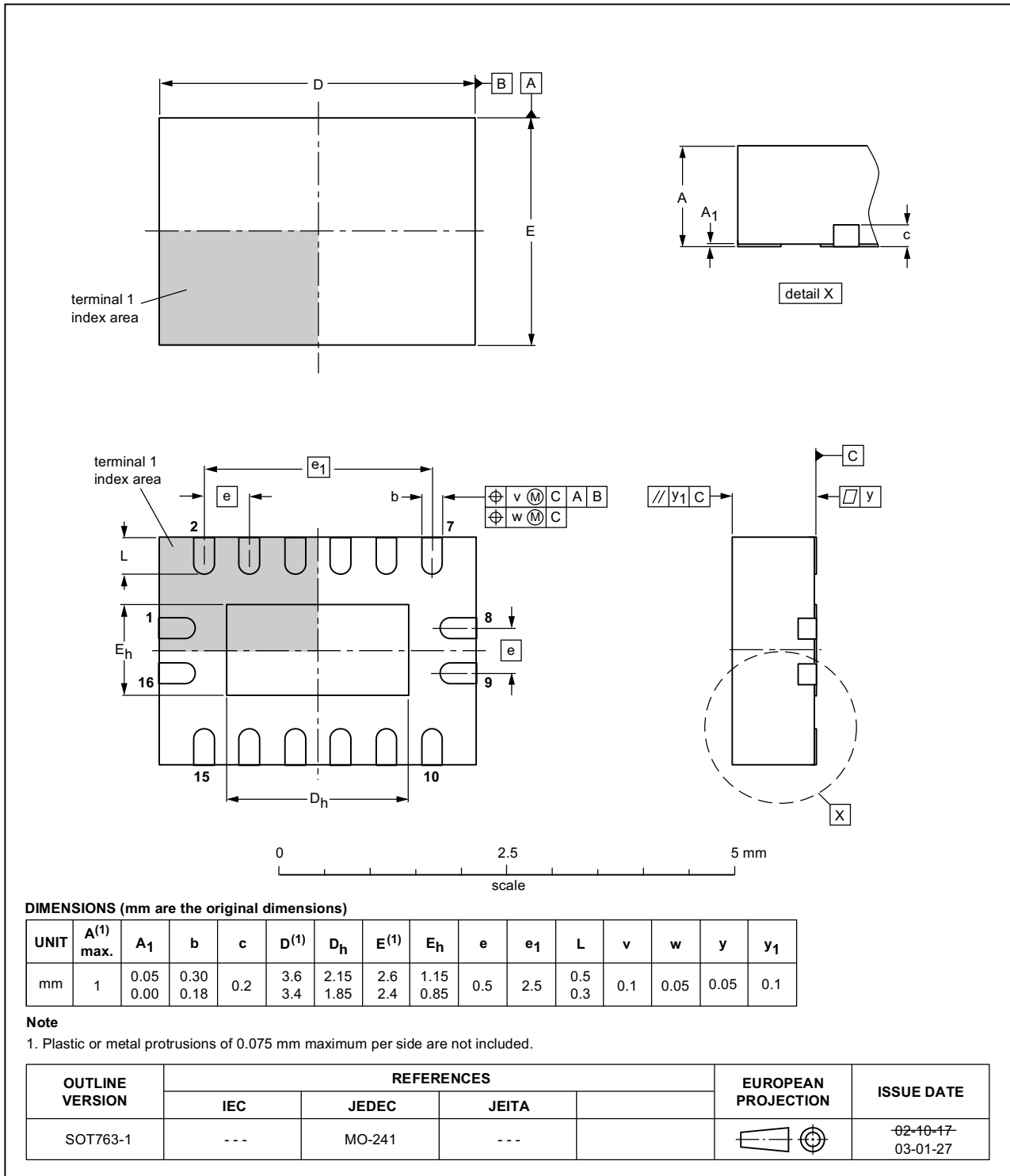

Fig 22. Package outline SOT763-1 (DHVQFN16)

15. Abbreviations

Table 9. Abbreviations

Acronym	Description
CMOS	Complementary Metal-Oxide Semiconductor
DUT	Device Under Test
ESD	ElectroStatic Discharge
HBM	Human Body Model
MM	Machine Model
TTL	Transistor-Transistor Logic

16. Revision history

Table 10. Revision history

Document ID	Release date	Data sheet status	Change notice	Supersedes
74HC_HCT4060_3	20080714	Product data sheet	-	74HC_HCT4060_CNV_2
Modifications:	<ul style="list-style-type: none"> The format of this data sheet has been redesigned to comply with the new identity guidelines of NXP Semiconductors. Legal texts have been adapted to the new company name where appropriate. Section 4: DHVQFN16 package added. Section 8: derating values added for DHVQFN16 package. Section 14: outline drawing added for DHVQFN16 package. 			
74HC_HCT4060_CNV_2	19970901	Product specification	-	-

17. Legal information

18. Data sheet status

Document status ^{[1][2]}	Product status ^[3]	Definition
Objective [short] data sheet	Development	This document contains data from the objective specification for product development.
Preliminary [short] data sheet	Qualification	This document contains data from the preliminary specification.
Product [short] data sheet	Production	This document contains the product specification.

[1] Please consult the most recently issued document before initiating or completing a design.

[2] The term 'short data sheet' is explained in section "Definitions".

[3] The product status of device(s) described in this document may have changed since this document was published and may differ in case of multiple devices. The latest product status information is available on the Internet at URL <http://www.nxp.com>.

18.1 Definitions

Draft — The document is a draft version only. The content is still under internal review and subject to formal approval, which may result in modifications or additions. NXP Semiconductors does not give any representations or warranties as to the accuracy or completeness of information included herein and shall have no liability for the consequences of use of such information.

Short data sheet — A short data sheet is an extract from a full data sheet with the same product type number(s) and title. A short data sheet is intended for quick reference only and should not be relied upon to contain detailed and full information. For detailed and full information see the relevant full data sheet, which is available on request via the local NXP Semiconductors sales office. In case of any inconsistency or conflict with the short data sheet, the full data sheet shall prevail.

18.2 Disclaimers

General — Information in this document is believed to be accurate and reliable. However, NXP Semiconductors does not give any representations or warranties, expressed or implied, as to the accuracy or completeness of such information and shall have no liability for the consequences of use of such information.

Right to make changes — NXP Semiconductors reserves the right to make changes to information published in this document, including without limitation specifications and product descriptions, at any time and without notice. This document supersedes and replaces all information supplied prior to the publication hereof.

Suitability for use — NXP Semiconductors products are not designed, authorized or warranted to be suitable for use in medical, military, aircraft, space or life support equipment, nor in applications where failure or

malfunction of an NXP Semiconductors product can reasonably be expected to result in personal injury, death or severe property or environmental damage. NXP Semiconductors accepts no liability for inclusion and/or use of NXP Semiconductors products in such equipment or applications and therefore such inclusion and/or use is at the customer's own risk.

Applications — Applications that are described herein for any of these products are for illustrative purposes only. NXP Semiconductors makes no representation or warranty that such applications will be suitable for the specified use without further testing or modification.

Limiting values — Stress above one or more limiting values (as defined in the Absolute Maximum Ratings System of IEC 60134) may cause permanent damage to the device. Limiting values are stress ratings only and operation of the device at these or any other conditions above those given in the Characteristics sections of this document is not implied. Exposure to limiting values for extended periods may affect device reliability.

Terms and conditions of sale — NXP Semiconductors products are sold subject to the general terms and conditions of commercial sale, as published at <http://www.nxp.com/profile/terms>, including those pertaining to warranty, intellectual property rights infringement and limitation of liability, unless explicitly otherwise agreed to in writing by NXP Semiconductors. In case of any inconsistency or conflict between information in this document and such terms and conditions, the latter will prevail.

No offer to sell or license — Nothing in this document may be interpreted or construed as an offer to sell products that is open for acceptance or the grant, conveyance or implication of any license under any copyrights, patents or other industrial or intellectual property rights.

18.3 Trademarks

Notice: All referenced brands, product names, service names and trademarks are the property of their respective owners.

19. Contact information

For more information, please visit: <http://www.nxp.com>

For sales office addresses, please send an email to: salesaddresses@nxp.com

20. Contents

1	General description	1
2	Features	1
3	Applications	1
4	Ordering information	2
5	Functional diagram	2
6	Pinning information	4
6.1	Pinning	4
6.2	Pin description	4
7	Functional description	5
8	Limiting values	5
9	Recommended operating conditions	6
10	Static characteristics	6
11	Dynamic characteristics	10
12	Waveforms	12
13	RC oscillator	15
13.1	Timing component limitations	15
13.2	Typical crystal oscillator circuit	15
14	Package outline	18
15	Abbreviations	23
16	Revision history	23
17	Legal information	24
18	Data sheet status	24
18.1	Definitions	24
18.2	Disclaimers	24
18.3	Trademarks	24
19	Contact information	24
20	Contents	25

Please be aware that important notices concerning this document and the product(s) described herein, have been included in section 'Legal information'.



© NXP B.V. 2008.

All rights reserved.

For more information, please visit: <http://www.nxp.com>

For sales office addresses, please send an email to: salesaddresses@nxp.com

Date of release: 14 July 2008

Document identifier: 74HC_HCT4060_3