

CD74AC04, CD74ACT04, CD74AC05, CD74ACT05

Hex Inverters

Features

- CD74AC04, CD74ACT04 Active Outputs
- CD74AC05, CD74ACT05 Open-Drain Outputs
- Buffered Inputs
- Typical Propagation Delay
 - 3.5ns at $V_{CC} = 5V$, $T_A = 25^\circ C$, $C_L = 50pF$
- Exceeds 2kV ESD Protection MIL-STD-883, Method 3015
- SCR-Latchup-Resistant CMOS Process and Circuit Design
- Speed of Bipolar FAST™/AS/S with Significantly Reduced Power Consumption
- Balanced Propagation Delays
- AC Types Feature 1.5V to 5.5V Operation and Balanced Noise Immunity at 30% of the Supply
- $\pm 24mA$ Output Drive Current
 - Fanout to 15 FAST™ ICs
 - Drives 50Ω Transmission Lines

Description

The CD74AC04, CD74ACT04, CD74AC05 and CD74ACT05 are hex inverters that utilize the Harris Advanced CMOS Logic technology.

Ordering Information

PART NUMBER	TEMP. RANGE (°C)	PACKAGE	PKG. NO.
CD74AC04E	-55 to 125	14 Ld PDIP	E14.3
CD74ACT04E	-55 to 125	14 Ld PDIP	E14.3
CD74AC05E	-55 to 125	14 Ld PDIP	E14.3
CD74ACT05E	-55 to 125	14 Ld PDIP	E14.3
CD74AC04M	-55 to 125	14 Ld SOIC	M14.15
CD74ACT04M	-55 to 125	14 Ld SOIC	M14.15
CD74AC05M	-55 to 125	14 Ld SOIC	M14.15
CD74ACT05M	-55 to 125	14 Ld SOIC	M14.15

NOTES:

1. When ordering, use the entire part number. Add the suffix 96 to obtain the variant in the tape and reel.
2. Wafer and die for this part number is available which meets all electrical specifications. Please contact your local sales office or Harris customer service for ordering information.

Pinout

CD74AC04, CD74ACT04, CD74AC05, CD74ACT05
(PDIP, SOIC)
TOP VIEW

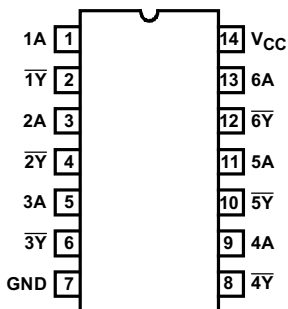

Functional Diagram

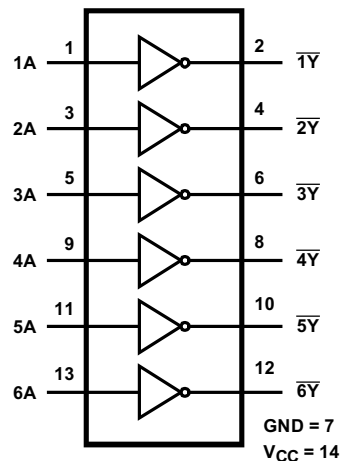

TRUTH TABLE

CD74AC/ACT04		CD74AC/ACT05	
INPUT	OUTPUT	INPUT	OUTPUT
L	H	L	Z
H	L	H	L

Z = High Impedance

CD74AC04, CD74ACT04, CD74AC05, CD74ACT05

Absolute Maximum Ratings

DC Supply Voltage, V_{CC}	-0.5V to 6V
DC Input Diode Current, I_{IK}	
For $V_I < -0.5V$ or $V_I > V_{CC} + 0.5V$	$\pm 20mA$
DC Output Diode Current, I_{OK}	
For $V_O < -0.5V$ or $V_O > V_{CC} + 0.5V$	$\pm 50mA$
DC Output Source or Sink Current per Output Pin, I_O	
For $V_O > -0.5V$ or $V_O < V_{CC} + 0.5V$	$\pm 50mA$
DC V_{CC} or Ground Current, I_{CC} or I_{GND} (Note 3)	$\pm 100mA$

Thermal Information

Thermal Resistance (Typical, Note 5)	θ_{JA} ($^{\circ}C/W$)
PDIP Package	90
SOIC Package	175
Maximum Junction Temperature (Plastic Package)	150 $^{\circ}C$
Maximum Storage Temperature Range	-65 $^{\circ}C$ to 150 $^{\circ}C$
Maximum Lead Temperature (Soldering 10s)	300 $^{\circ}C$

Operating Conditions

Temperature Range, T_A	-55 $^{\circ}C$ to 125 $^{\circ}C$
Supply Voltage Range, V_{CC} (Note 4)	
AC Types	1.5V to 5.5V
ACT Types	4.5V to 5.5V
DC Input or Output Voltage, V_I, V_O	0V to V_{CC}
Input Rise and Fall Slew Rate, dt/dv	
AC Types, 1.5V to 3V	50ns (Max)
AC Types, 3.6V to 5.5V	20ns (Max)
ACT Types, 4.5V to 5.5V	10ns (Max)

CAUTION: Stresses above those listed in "Absolute Maximum Ratings" may cause permanent damage to the device. This is a stress only rating and operation of the device at these or any other conditions above those indicated in the operational sections of this specification is not implied.

NOTES:

3. For up to 4 outputs per device, add $\pm 25mA$ for each additional output.
4. Unless otherwise specified, all voltages are referenced to ground.
5. θ_{JA} is measured with the component mounted on an evaluation PC board in free air.

DC Electrical Specifications

PARAMETER	SYMBOL	TEST CONDITIONS		V_{CC} (V)	25 $^{\circ}C$		-40 $^{\circ}C$ TO 85 $^{\circ}C$		-55 $^{\circ}C$ TO 125 $^{\circ}C$		UNITS	
		V_I (V)	I_O (mA)		MIN	MAX	MIN	MAX	MIN	MAX		
AC TYPES												
High Level Input Voltage	V_{IH}	-	-	1.5	1.2	-	1.2	-	1.2	-	V	
				3	2.1	-	2.1	-	2.1	-	V	
				5.5	3.85	-	3.85	-	3.85	-	V	
Low Level Input Voltage	V_{IL}	-	-	1.5	-	0.3	-	0.3	-	0.3	V	
				3	-	0.9	-	0.9	-	0.9	V	
				5.5	-	1.65	-	1.65	-	1.65	V	
High Level Output Voltage (04)	V_{OH}	V_{IH} or V_{IL}	-0.05	-0.05	1.5	1.4	-	1.4	-	1.4	-	V
			-0.05	-0.05	3	2.9	-	2.9	-	2.9	-	V
			-0.05	-0.05	4.5	4.4	-	4.4	-	4.4	-	V
			-4	-4	3	2.58	-	2.48	-	2.4	-	V
			-24	-24	4.5	3.94	-	3.8	-	3.7	-	V
			-75 (Note 6, 7)	-75	5.5	-	-	3.85	-	-	-	V
			-50 (Note 6, 7)	-50	5.5	-	-	-	-	3.85	-	V

CD74AC04, CD74ACT04, CD74AC05, CD74ACT05

DC Electrical Specifications (Continued)

PARAMETER	SYMBOL	TEST CONDITIONS		V _{CC} (V)	25°C		-40°C TO 85°C		-55°C TO 125°C		UNITS	
		V _I (V)	I _O (mA)		MIN	MAX	MIN	MAX	MIN	MAX		
Low Level Output Voltage	V _{OL}	V _{IH} or V _{IL}	0.05	0.05	1.5	-	0.1	-	0.1	-	0.1	V
			0.05	0.05	3	-	0.1	-	0.1	-	0.1	V
			0.05	0.05	4.5	-	0.1	-	0.1	-	0.1	V
			12	12	3	-	0.36	-	0.44	-	0.5	V
			24	24	4.5	-	0.36	-	0.44	-	0.5	V
			75 (Note 6, 7)	75 (Note 6, 7)	5.5	-	-	-	1.65	-	-	V
50 (Note 6, 7)	50 (Note 6, 7)	5.5	-	-	-	-	-	1.65	V			
Input Leakage Current	I _I	V _{CC} or GND	-	5.5	-	±0.1	-	±1	-	±1	μA	
Quiescent Supply Current, SSI	I _{CC}	V _{CC} or GND	0	5.5	-	4	-	40	-	80	μA	
ACT TYPES												
High Level Input Voltage	V _{IH}	-	-	4.5 to 5.5	2	-	2	-	2	-	V	
Low Level Input Voltage	V _{IL}	-	-	4.5 to 5.5	-	0.8	-	0.8	-	0.8	V	
High Level Output Voltage (04)	V _{OH}	V _{IH} or V _{IL}	-0.05	-0.05	4.5	4.4	-	4.4	-	4.4	-	V
			-24	-24	4.5	3.94	-	3.8	-	3.7	-	V
			-75	-75	5.5	-	-	3.85	-	-	-	V
			-50	-50	5.5	-	-	-	-	3.85	-	V
Low Level Output Voltage	V _{OL}	V _{IH} or V _{IL}	0.05	0.05	4.5	-	0.1	-	0.1	-	0.1	V
			24	24	4.5	-	0.36	-	0.44	-	0.5	V
			75 (Note 6, 7)	75 (Note 6, 7)	5.5	-	-	-	1.65	-	-	V
			50 (Note 6, 7)	50 (Note 6, 7)	5.5	-	-	-	-	-	1.65	V
Input Leakage Current	I _I	V _{CC} or GND	-	5.5	-	±0.1	-	±1	-	±1	μA	
Quiescent Supply Current, SSI	I _{CC}	V _{CC} or GND	0	5.5	-	4	-	40	-	80	μA	
Additional Supply Current per Input Pin TTL Inputs High 1 Unit Load	ΔI _{CC}	V _{CC} -2.1	-	4.5 to 5.5	-	2.4	-	2.8	-	3	mA	

NOTES:

- Test one output at a time for a 1-second maximum duration. Measurement is made by forcing current and measuring voltage to minimize power dissipation.
- Test verifies a minimum 50Ω transmission-line-drive capability at 85°C, 75Ω at 125°C.

ACT Input Load Table

INPUT	UNIT LOAD
nA	0.18

NOTE: Unit load is ΔI_{CC} limit specified in DC Electrical Specifications Table, e.g., 2.4mA max at 25°C.

CD74AC04, CD74ACT04, CD74AC05, CD74ACT05

Switching Specifications Input $t_r, t_f = 3\text{ns}$, $C_L = 50\text{pF}$ (Worst Case)

PARAMETER	SYMBOL	V_{CC} (V)	-40°C TO 85°C			-55°C TO 125°C			UNITS
			MIN	TYP	MAX	MIN	TYP	MAX	
AC TYPES									
Propagation Delay, Input to Output (CD74AC/ACT04)	t_{PLH}, t_{PHL}	1.5	-	-	74	-	-	81	ns
		3.3 (Note 9)	2.3	-	8.3	2.3	-	9.1	ns
		5 (Note 10)	1.7	-	5.9	1.6	-	6.5	ns
Propagation Delay, High Z to Output Low (CD74AC/ACT05)	t_{PZL}	1.5	-	-	74	-	-	81	ns
		3.3	2.3	-	8.3	2.3	-	9.1	ns
		5	1.7	-	5.9	1.6	-	6.5	ns
Propagation Delay, Output Low to High Z (CD74AC/ACT05)	t_{PLZ}	1.5	-	-	94	-	-	103	ns
		3.3	3	-	10.4	2.9	-	11.5	ns
		5	2.2	-	7.5	2.1	-	8.2	ns
Input Capacitance	C_I	-	-	-	10	-	-	10	pF
Power Dissipation Capacitance	C_{PD} (Note 11)	-	-	105	-	-	105	-	pF
ACT TYPES									
Propagation Delay, Input to Output (CD74AC/ACT04)	t_{PLH}, t_{PHL}	5 (Note 10)	2.4	-	8.5	2.3	-	9.3	ns
Propagation Delay, Output Low to High Z	t_{PLZ}	5	2.8	-	9.8	2.7	-	10.8	ns
Propagation Delay, High Z to Output Low (CD74AC/ACT05)	t_{PZL}	5	2.4	-	8.5	2.3	-	9.3	ns
Input Capacitance	C_I	-	-	-	10	-	-	10	pF
Power Dissipation Capacitance	C_{PD} (Note 11)	-	-	105	-	-	105	-	pF

NOTES:

8. Limits tested at 100%.
9. 3.3V Min at 3.6V, Max at 3V.
10. 5V Min at 5.5V, Max at 4.5V.
11. C_{PD} is used to determine the dynamic power consumption per gate.
 AC: $P_D = V_{CC}^2 f_i (C_{PD} + C_L)$
 ACT: $P_D = V_{CC}^2 f_i (C_{PD} + C_L) + V_{CC} \Delta I_{CC}$ where f_i = input frequency, C_L = output load capacitance, V_{CC} = supply voltage.

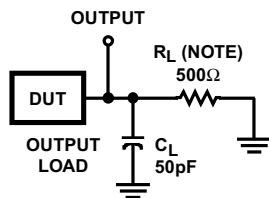

NOTE: For AC Series Only: When $V_{CC} = 1.5\text{V}$, $R_L = 1\text{k}\Omega$.

	CD74AC	CD74ACT
Input Level	V_{CC}	3V
Input Switching Voltage, V_S	0.5 V_{CC}	1.5V
Output Switching Voltage, V_S	0.5 V_{CC}	0.5 V_{CC}

FIGURE 1. PROPAGATION DELAY TIMES

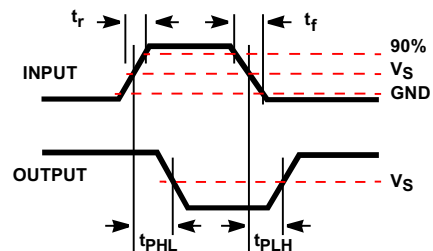

FIGURE 2. WAVEFORMS

CD74AC04, CD74ACT04, CD74AC05, CD74ACT05

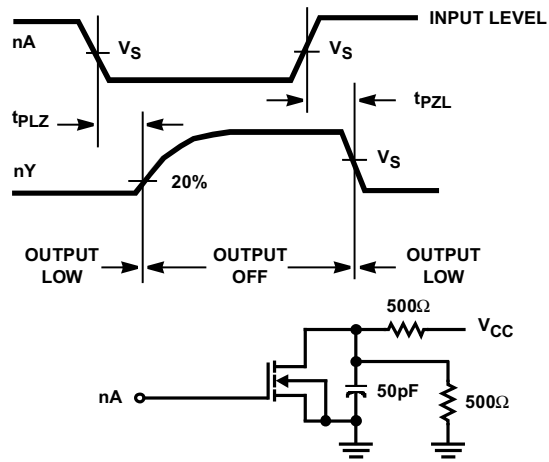

FIGURE 3. PROPAGATION DELAY TIMES AND TEST CIRCUIT

IMPORTANT NOTICE

Texas Instruments and its subsidiaries (TI) reserve the right to make changes to their products or to discontinue any product or service without notice, and advise customers to obtain the latest version of relevant information to verify, before placing orders, that information being relied on is current and complete. All products are sold subject to the terms and conditions of sale supplied at the time of order acknowledgement, including those pertaining to warranty, patent infringement, and limitation of liability.

TI warrants performance of its semiconductor products to the specifications applicable at the time of sale in accordance with TI's standard warranty. Testing and other quality control techniques are utilized to the extent TI deems necessary to support this warranty. Specific testing of all parameters of each device is not necessarily performed, except those mandated by government requirements.

CERTAIN APPLICATIONS USING SEMICONDUCTOR PRODUCTS MAY INVOLVE POTENTIAL RISKS OF DEATH, PERSONAL INJURY, OR SEVERE PROPERTY OR ENVIRONMENTAL DAMAGE ("CRITICAL APPLICATIONS"). TI SEMICONDUCTOR PRODUCTS ARE NOT DESIGNED, AUTHORIZED, OR WARRANTED TO BE SUITABLE FOR USE IN LIFE-SUPPORT DEVICES OR SYSTEMS OR OTHER CRITICAL APPLICATIONS. INCLUSION OF TI PRODUCTS IN SUCH APPLICATIONS IS UNDERSTOOD TO BE FULLY AT THE CUSTOMER'S RISK.

In order to minimize risks associated with the customer's applications, adequate design and operating safeguards must be provided by the customer to minimize inherent or procedural hazards.

TI assumes no liability for applications assistance or customer product design. TI does not warrant or represent that any license, either express or implied, is granted under any patent right, copyright, mask work right, or other intellectual property right of TI covering or relating to any combination, machine, or process in which such semiconductor products or services might be or are used. TI's publication of information regarding any third party's products or services does not constitute TI's approval, warranty or endorsement thereof.