



High Speed CMOS Bus Exchange Switches

QS54/74QST3383
QS54/74QST3583

FEATURES/BENEFITS

- 5Ω switches connect inputs to outputs
- Direct bus connection when switches on
- Zero propagation delay
- Undershoot Clamp diodes on all inputs
- Low power CMOS proprietary technology
- 3583 is 25Ω version for low noise
- Bus exchange allows nibble swap
- Zero ground bounce in flow-through mode
- TTL-compatible input and output levels
- Available in 24-pin DIP, ZIP, SOIC and QSOP

DESCRIPTION

The QS54/74QST3383 and 3583 each provide two sets of ten high-speed CMOS TTL-compatible bus switches. The low on resistance (5Ω) of the 3383 allows inputs to be connected to outputs without adding propagation delay and without generating additional ground bounce noise. The 3583 adds an internal 25Ω resistor to reduce reflection noise in high speed applications. The bus enable (BE) signal turns the switches on. The bus exchange (BX) signal provides nibble swap of the AB and CD pairs of signals. This exchange configuration allows byte swapping of buses in systems. It can also be used as a quad 2-to-1 multiplexer and to create low delay barrel shifters, etc.

FUNCTIONAL BLOCK DIAGRAM

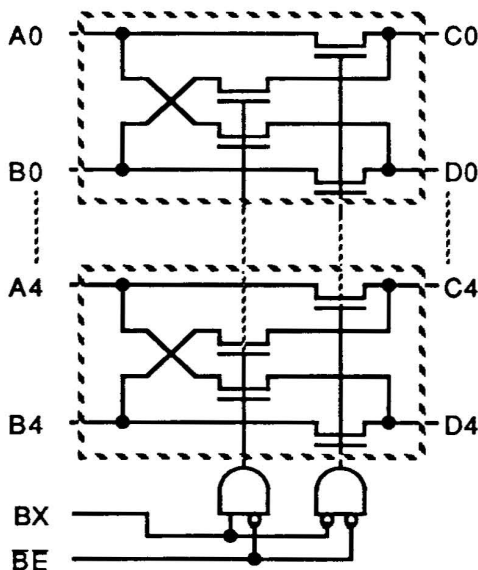

PIN DESCRIPTION

Name	I/O	Function
A0-4, B0-4	I/O	Buses A, B
C0-4, D0-4	I/O	Buses C, D
BE	I	Bus Switch Enable
BX	I	Bus Exchange

FUNCTION TABLE

BE	BX	A0-4	B0-4	Function
H	X	Hi-Z	Hi-Z	Disconnect
L	L	C0-4	D0-4	Connect
L	H	D0-4	C0-4	Exchange

PIN CONFIGURATIONS

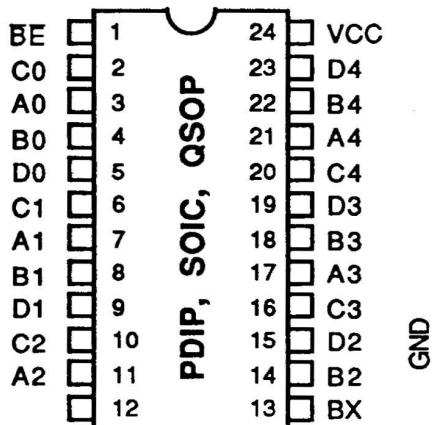

ALL PINS TOP VIEW

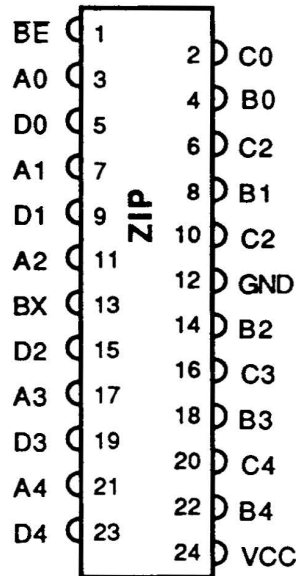

ABSOLUTE MAXIMUM RATINGS

Supply Voltage to Ground..... -0.5V to +7.0V
 DC Switch Voltage V_S -0.5V to $V_{CC} + 0.5V$
 DC Input Voltage V_I -0.5V to $V_{CC} + 0.5V$
 AC Input Voltage (for a pulse width ≤ 20 ns)..... -3.0V
 DC Input Diode Current with $V_I < 0$ -20 mA
 DC Output Current Max. sink current/pin..... 120 mA
 Maximum Power Dissipation..... 0.5 watts
 T_{STG} Storage Temperature..... -65° to +165°C

CAPACITANCE

$T_a = 25^\circ C, f = 1$ MHz, $V_{in} = 0V, V_{out} = 0V$

Name	Description	Conditions	Typ	Max	Unit
Cin	Input Capacitance, Controls	$V_{in} = 0 V$	6		pF
Coff	A/B I/O Capacitance, Switch Off	$V_{in} = 0 V$	6		pF
Con	A/B I/O Capacitance, Switch On	$V_{in} = 0 V$	10		pF

Capacitance is guaranteed but not tested

QST3383, QST3583

DC ELECTRICAL CHARACTERISTICS OVER OPERATING RANGE

Commercial TA = 0° C to 70° C, Vcc = 5.0V±5% Military TA = -55° C to 125° C, Vcc = 5.0V±10%

Symbol	Parameter	Test Conditions	Min	Typ	Max	Unit	
Vih	Input HIGH Voltage	Guaranteed Logic HIGH for Control Inputs	2.0	-	-	Volts	
Vil	Input LOW Voltage	Guaranteed Logic LOW for Control Inputs	-	-	0.8	Volts	
<i>i</i> _{in}	Input Leakage Current	0 ≤ Vin ≤ Vcc	-	-	1	μA	
<i>i</i> _{oz}	Off State Current (Hi-Z)	0 ≤ A, B ≤ Vcc	-	.001	1	μA	
<i>i</i> _{os}	Short Circuit Current (2)	A (B) = 0V, B (A) = Vcc	100	-	-	mA	
Vic	Clamp Diode Voltage	Vcc = Min, <i>i</i> _{in} = -18 mA	-	-0.7	-1.2	Volts	
Ron	Switch On Resistance (Note 3)	Vcc = Min, Vin = 0.0 Volts <i>i</i> _{on} = 48 mA	33XX	-	5	7	Ω
			35XX	24	28	35	Ω
		Vcc = Min, Vin = 2.4 Volts <i>i</i> _{on} = 15 mA	33XX	-	10	15	Ω
			35XX	24	35	48	Ω

Notes:

1. Typical values indicate V_{CC}=5.0V and T_A=25°C.
2. Not more than one output should be used to test this high power condition, and the duration is ≤1 second.
3. Measured by voltage drop between A and B pin at indicated current through the switch. On resistance is determined by the lower of the voltages on the two (A, B) pins.

On Resistance vs Vin @ 4.75 Vcc

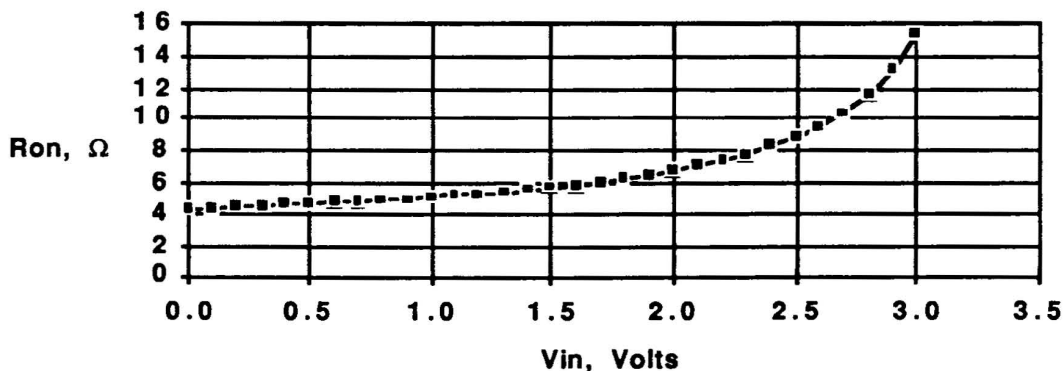

POWER SUPPLY CHARACTERISTICS

Symbol	Parameter	Test Conditions (1)	Min	Typ	Max	Unit
I _{cc}	Quiescent Power Supply Current	V _{cc} = MAX, V _i = GND or V _{cc} , f = 0	-	-	1.5	mA
ΔI _{cc}	Pwr Supply Current, per Input High (2)	V _{cc} = MAX, Input = 3.4 V, f = 0 Per control input	-	-	2.5	mA
Q _{ccd}	Dynamic Pwr Supply Current per mHz (3)	V _{cc} = MAX, A & B pins open, Control input toggling @ 50% duty cycle	-	-	0.25	mA/ mHz
I _c	Total Power Supply Current (4,5)	V _{cc} = MAX, A & B pins at 0.0V, Control inputs toggling @ 50% duty cycle V _{ih} = 3.4V, f clock = 10 mHz	-	-	9.0	mA

1. For conditions shown as MIN or MAX use the appropriate values specified under DC specifications.
2. Per TTL driven input (V_i=3.4V, control inputs only). A and B pins do not contribute to I_{cc}.
3. This current applies to the control inputs only and represents the current required to switch internal capacitance at the specified frequency. The A and B inputs generate no significant AC or DC currents as they transition. This parameter is not tested but is guaranteed by design.
4. I_c = I_{Quiescent} + I_{Inputs} + I_{Dynamic}
 $I_c = I_{cc} + \Delta I_{cc} Dh Nt + Q_{ccd} (fi Ni)$
 I_{cc} = Quiescent Current
 ΔI_{cc} = Power Supply Current for each TTL High input (V_i=3.4V, control inputs only)
 Dh = Duty Cycle for each TTL input that is High (control inputs only).
 Nt = Number of TTL inputs that are at DH (control inputs only).
 fi = frequency that the inputs are toggled (control inputs only).
5. Note that activity on A and/or B inputs do not contribute to I_c if A and B inputs are between gnd and V_{cc}. The switches merely connect and pass through activity on these pins. For example: If the control inputs are at 0V and the switches are on, I_c will be equal to I_{cc} only regardless of activity on the A and B pins.

QST3383, QST3583

SWITCHING CHARACTERISTICS OVER OPERATING RANGE

Commercial TA = 0° C to 70°C, Vcc = 5.0V±5% Military TA = -55°C to 125° C, Vcc = 5.0V±10%
 Cload = 50 pF, Rload = 500Ω unless otherwise noted

Symbol	Description	Note	Com		Mil		Unit
			Min	Max	Min	Max	
t PLH t PHL	Data Propagation Delay Ai to Bi, Bi to Ai	3		**		**	ns
t PZH t PZL	Switch Turn On Delay BE to Ai, Bi		1.5	6.5	1.5	7.5	
t PLZ t PZL	Switch Turn Off Delay BE to Ai, Bi		1.5	5.5	1.5	6.5	
t BX	Switch Multiplex Delay BX to Ai, Bi		1.5	6.5	1.5	7.5	

Notes:

- 1) See Test Circuit and Waveforms. Minimums guaranteed but not tested.
- 2) This parameter is guaranteed by design but not tested.
- 3) The bus switch contributes no propagation delay other than the RC delay of the on resistance of the switch and the load capacitance. The time constant for the switch and load alone is of the order of 0.25 ns for 50 pF load. Since this time constant is much smaller than the rise/fall times of typical driving signals, it adds very little propagation delay to the system. Propagation delay of the bus switch when used in a system is determined by the driving circuit on the driving side of the switch and its interaction with the load on the driven side.