

74LVT240

3.3V ABT Octal Buffer/Line Driver with TRI-STATE® Outputs

General Description

The LVT240 is an inverting octal buffer and line driver designed to be employed as a memory address driver, clock driver and bus oriented transmitter or receiver which provides improved PC board density.

These octal buffers and line drivers are designed for low-voltage (3.3V) V_{CC} applications, but with the capability to provide a TTL interface to a 5V environment. The LVT240 is fabricated with an advanced BiCMOS technology to achieve high speed operation similar to 5V ABT while maintaining a low power dissipation.

Features

- Input and output interface capability to systems at 5V V_{CC}
- Bus-Hold data inputs eliminate the need for external pull-up resistors to hold unused inputs
- Live insertion/extraction permitted
- Power Up/Down high impedance provides glitch-free bus loading
- Outputs source/sink $-32\text{ mA}/+64\text{ mA}$
- Available in SOIC JEDEC, SOIC EIAJ, TSSOP and SSOPII
- Functionally compatible with the 74 series 240
- Latch-up performance exceeds 500 mA

Logic Symbol

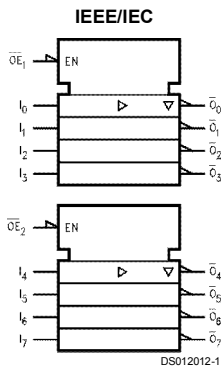

Connection Diagram

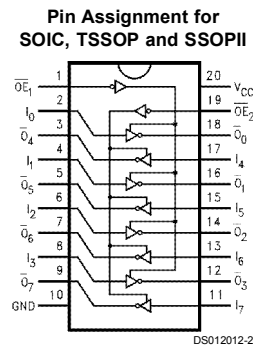

TRI-STATE® is a registered trademark of National Semiconductor Corporation.

Truth Tables

Inputs		Outputs (Pins 12, 14, 16, 18)
\overline{OE}_1	I_n	
L	L	H
L	H	L
H	X	Z

H = HIGH Voltage Level
 L = LOW Voltage Level
 X = Immaterial
 Z = High Impedance

Inputs		Outputs (Pins 3, 5, 7, 9)
\overline{OE}_2	I_n	
L	L	H
L	H	L
H	X	Z

Pin Names	Description
$\overline{OE}_1, \overline{OE}_2$	TRI-STATE Output Enable Inputs
I_0-I_7	Inputs
$\overline{O}_0-\overline{O}_7$	TRI-STATE Outputs

	SOIC JEDEC	SOIC EIAJ	TSSOP	SSOPII
Order Number	74LVT240WM 74LVT240WMX	74LVT240SJ 74LVT240SJX	74LVT240MTC 74LVT240MTCX	74LVT240MSA 74LVT240MSAX
See NS Package Number	M20B	M20D	MTC20	MSA20

Absolute Maximum Ratings (Note 1)

Symbol	Parameter	Value	Conditions	Units
V_{CC}	Supply Voltage	-0.5 to +7.0		V
V_I	DC Input Voltage	-0.5 to +7.0		V
V_O	DC Output Voltage	-0.5 to +7.0	Output in TRI-STATE	V
		-0.5 to +7.0	Output in High or Low State (Note 2)	V
I_{IK}	DC Input Diode Current	-50	$V_I < GND$	mA
I_{OK}	DC Output Diode Current	-50	$V_O < GND$	mA
I_O	DC Output Current	64	$V_O > V_{CC}$ Output at High State	mA
		128	$V_O > V_{CC}$ Output at Low State	
I_{CC}	DC Supply Current per Supply Pin	±64		mA
I_{GND}	DC Ground Current per Ground Pin	±128		mA
T_{STG}	Storage Temperature	-65 to +150		°C

Recommended Operating Conditions

Symbol	Parameter	Min	Max	Units	
V_{CC}	Supply Voltage	Operating	2.0	3.6	V
		Data Retention	1.5	3.6	
V_I	Input Voltage	0	3.6	V	
V_O	Output Voltage	HIGH or LOW State	0	V_{CC}	V
		TRI-STATE	0	5.5	
I_{OH}	High-Level Output Current		-32	mA	
I_{OL}	Low-Level Output Current		64		
T_A	Free-Air Operating Temperature	-40	85	°C	
$\Delta t/\Delta V$	Input Edge Rate, $V_{IN} = 0.8V-2.0V$, $V_{CC} = 3.0V$	0	10	ns/V	

Note 1: The Absolute Maximum Ratings are those values beyond which the safety of the device cannot be guaranteed. The device should not be operated at these limits. The parametric values defined in the "Electrical Characteristics" table are not guaranteed at the Absolute Maximum Ratings. The "Recommended Operating Conditions" table will define the conditions for actual device operation.

Note 2: I_O Absolute Maximum Rating must be observed.

DC Electrical Characteristics

Symbol	Parameter	V_{CC} (V)	$T_A = -40^\circ C$ to $+85^\circ C$			Units	Conditions
			Min	Typ (Note 3)	Max		
V_{IK}	Input Clamp Diode Voltage	2.7		-1.2	V	$I_I = -18$ mA	
V_{IH}	Input HIGH Voltage	2.7-3.6	2.0		V	$V_O \leq 0.1V$ or $V_O \geq V_{CC} - 0.1V$	
V_{IL}	Input LOW Voltage	2.7-3.6		0.8			
V_{OH}	Output HIGH Voltage	2.7-3.6	$V_{CC}-0.2$		V	$I_{OH} = -100$ μA	
		2.7	2.2		V	$I_{OH} = -8$ mA	
		3.0	2.0		V	$I_{OH} = -32$ mA	
V_{OL}	Output LOW Voltage	2.7		0.2	V	$I_{OL} = 100$ μA	
		2.7		0.5	V	$I_{OL} = 24$ mA	
		3.0		0.4	V	$I_{OL} = 16$ mA	
		3.0		0.5	V	$I_{OL} = 32$ mA	
		3.0		0.55	V	$I_{OL} = 64$ mA	
$I_{I(HOLD)}$	Bus-Hold Input Minimum Drive	3.0	75		μA	$V_I = 0.8V$	
			-75		μA	$V_I = 2.0V$	
$I_{I(OD)}$	Bus-Hold Input Over-Drive Current to Change State	3.0	500		μA	(Note 4)	
			-500		μA	(Note 5)	

DC Electrical Characteristics (Continued)

Symbol	Parameter	V _{CC} (V)	T _A = -40°C to +85°C			Units	Conditions
			Min	Typ (Note 3)	Max		
I _I	Input Current	3.6		10	μA	V _I = 5.5V	
		Control Pins	3.6		±1	μA	V _I = 0V or V _{CC}
		Data Pins	3.6		-5	μA	V _I = 0V
					1	μA	V _I = V _{CC}
I _{OFF}	Power Off Leakage Current	0		±100	μA	0V ≤ V _I or V _O ≤ 5.5V	
I _{PU/PD} (Note 6)	Power up/down TRI-STATE Output Current	0–1.2V		±100	μA	V _O = 0.5V to V _{CC} V _I = GND or V _{CC}	
I _{OZL}	TRI-STATE Output Leakage Current	3.6		-5	μA	V _O = 0.5V	
I _{OZH}	TRI-STATE Output Leakage Current	3.6		5	μA	V _O = 3.0V	
I _{OZH+}	TRI-STATE Output Leakage Current	3.6		10	μA	V _{CC} < V _O ≤ 5.5V	
I _{CCH}	Power Supply Current	3.6		0.19	mA	Outputs High	
I _{CCL}	Power Supply Current	3.6		16.5	mA	Outputs Low	
I _{CCZ}	Power Supply Current	3.6		0.19	mA	Outputs Disabled	
I _{CCZ+}	Power Supply Current	3.6		0.19	mA	V _{CC} ≤ V _O ≤ 5.5V, Outputs Disabled	
ΔI _{CC}	Increase in Power Supply Current (Note 7)	3.6		0.2	mA	One Input at V _{CC} - 0.6V Other Inputs at V _{CC} or GND	

Note 3: All typical values are at V_{CC} = 3.3V, T_A = 25°C.

Note 4: An external driver must source at least the specified current to switch from LOW to HIGH.

Note 5: An external driver must sink at least the specified current to switch from HIGH to LOW.

Note 6: This parameter is valid for any V_{CC} between 0V and 1.2V at 25°C only.

Note 7: This is the increase in supply current for each input that is at the specified voltage level rather than V_{CC} or GND.

Dynamic Switching Characteristics (Note 8)

Symbol	Parameter	V _{CC} (V)	T _A = 25°C			Units	Conditions C _L = 50 pF, R _L = 500Ω
			Min	Typ	Max		
V _{OLP}	Quiet Output Maximum Dynamic V _{OL}	3.3		0.8		V	(Note 9)
V _{OLV}	Quiet Output Minimum Dynamic V _{OL}	3.3		-0.8		V	(Note 9)

Note 8: Characterized in SOIC package. Guaranteed parameter, but not tested.

Note 9: Max number of outputs defined as (n). n-1 data inputs are driven 0V to 3V. Output under test held LOW.

AC Electrical Characteristics for Test Methodology

Symbol	Parameter	T _A = -40°C to +85°C C _L = 50 pF, R _L = 500Ω					Units
		V _{CC} = 3.3V ±0.3V			V _{CC} = 2.7V		
		Min	Typ (Note 10)	Max	Min	Max	
t _{PLH}	Propagation Delay Data to Output	1.0		4.3	1.0	5.2	ns
t _{PHL}		1.0		4.3	1.0	5.0	
t _{PZH}	Output Enable Time	1.0		5.2	1.0	6.3	ns
t _{PZL}		1.0		5.2	1.0	6.7	
t _{PHZ}	Output Disable Time	1.8		5.6	1.8	6.3	ns
t _{PLZ}		1.8		5.1	1.8	5.6	

AC Electrical Characteristics for Test Methodology (Continued)

Symbol	Parameter	$T_A = -40^\circ\text{C to } +85^\circ\text{C}$ $C_L = 50\text{ pF, } R_L = 500\Omega$				Units
		$V_{CC} = 3.3V \pm 0.3V$			$V_{CC} = 2.7V$	
		Min	Typ (Note 10)	Max	Min	
t_{OSHL} t_{OSLH}	Output to Output Skew (Note 11)			1.0		ns

Note 10: All typical values are at $V_{CC} = 3.3V$, $T_A = 25^\circ\text{C}$.

Note 11: Skew is defined as the absolute value of the difference between the actual propagation delay for any two separate outputs of the same device. The specification applies to any outputs switching in the same direction, either HIGH to LOW (t_{OSHL}) or LOW to HIGH (t_{OSLH}). Parameter guaranteed by design.

Capacitance (Note 12)

Symbol	Parameter	Min	Typ	Max	Units	Conditions
C_{IN}	Input Capacitance		4		pF	$V_{CC} = 0V$, $V_I = 0V$ or V_{CC}
C_{OUT}	Output Capacitance		11		pF	$V_{CC} = 3.0V$, $V_O = 0V$ or V_{CC}

Note 12: Capacitance is measured at frequency $f = 1\text{ MHz}$, per MIL-STD-883B, Method 3012.

74LVT240 Ordering Information

The device number is used to form part of a simplified purchasing code where the package type and temperature range are defined as follows:

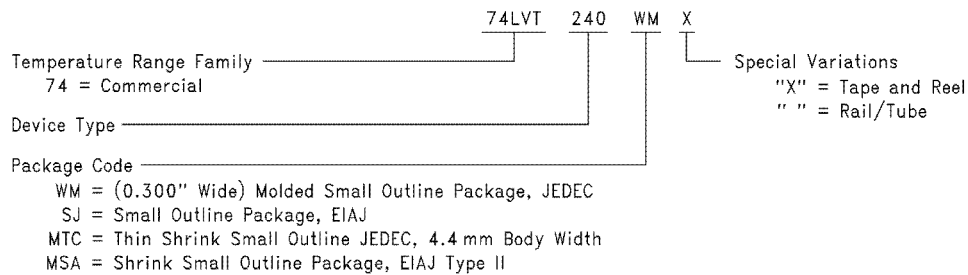

DS012012-3

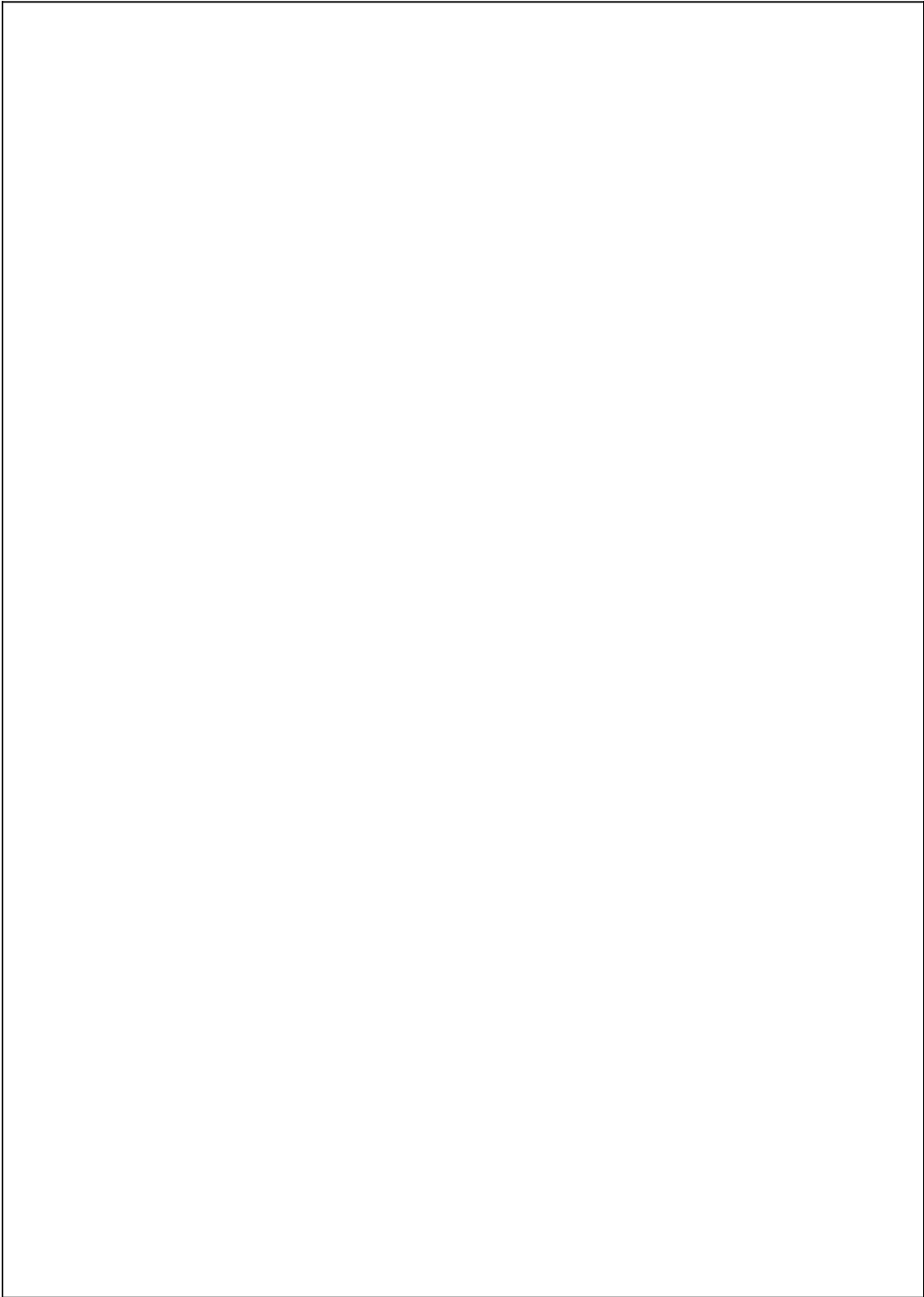

Physical Dimensions inches (millimeters) unless otherwise noted

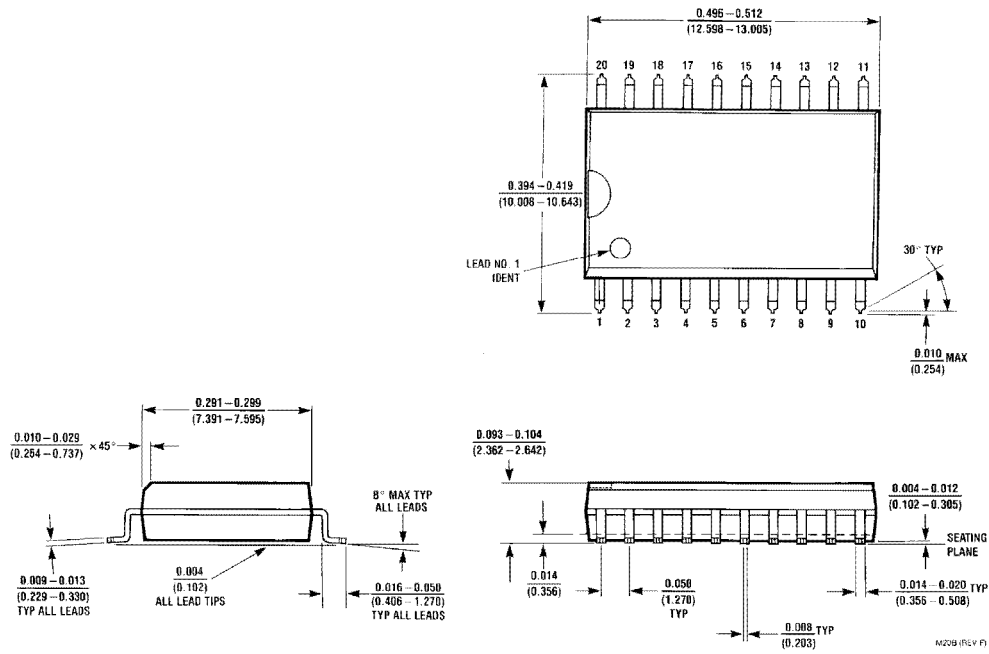

**20-Lead (0.300" Wide) Molded Small Outline Package, JEDEC
Order Number 74LVT240WM or 74LVT240WMX
NS Package Number M20B**

M20B (REV F)

Physical Dimensions inches (millimeters) unless otherwise noted (Continued)

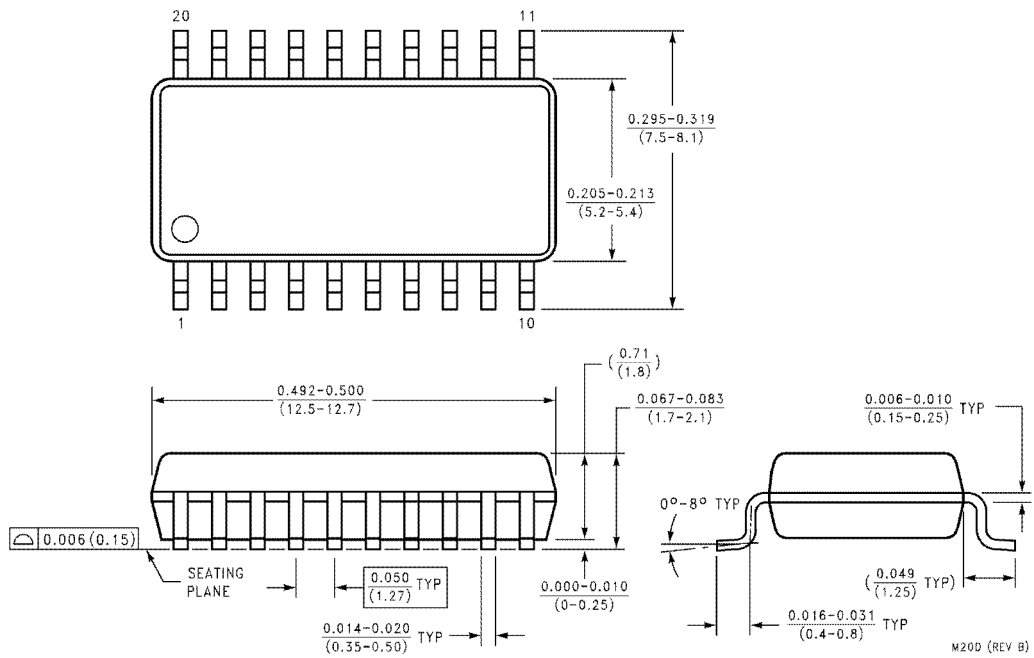

**20-Lead Molded Small Outline Package, EIAJ (SJ)
Order Number 74LVT240SJ or 74LVT240SJX
NS Package Number M20D**

Physical Dimensions inches (millimeters) unless otherwise noted (Continued)

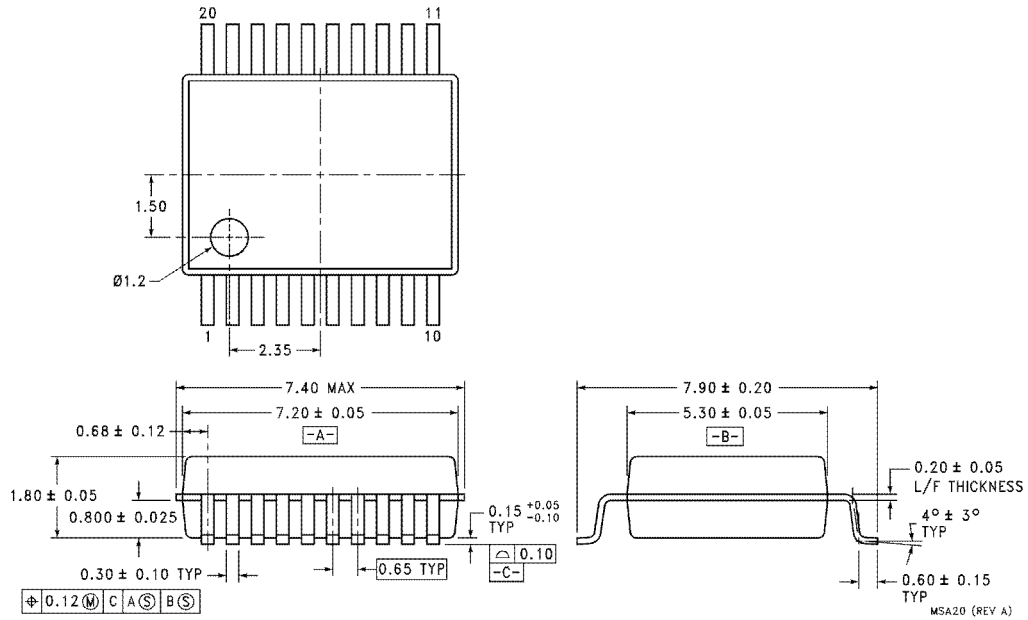

20-Lead Molded Shrink Small Outline Package, EIAJ Type II
Order Number 74LVT240MSA or 74LVT240MSAX
NS Package Number MSA20

Physical Dimensions inches (millimeters) unless otherwise noted (Continued)

DIMENSIONS METRIC ONLY

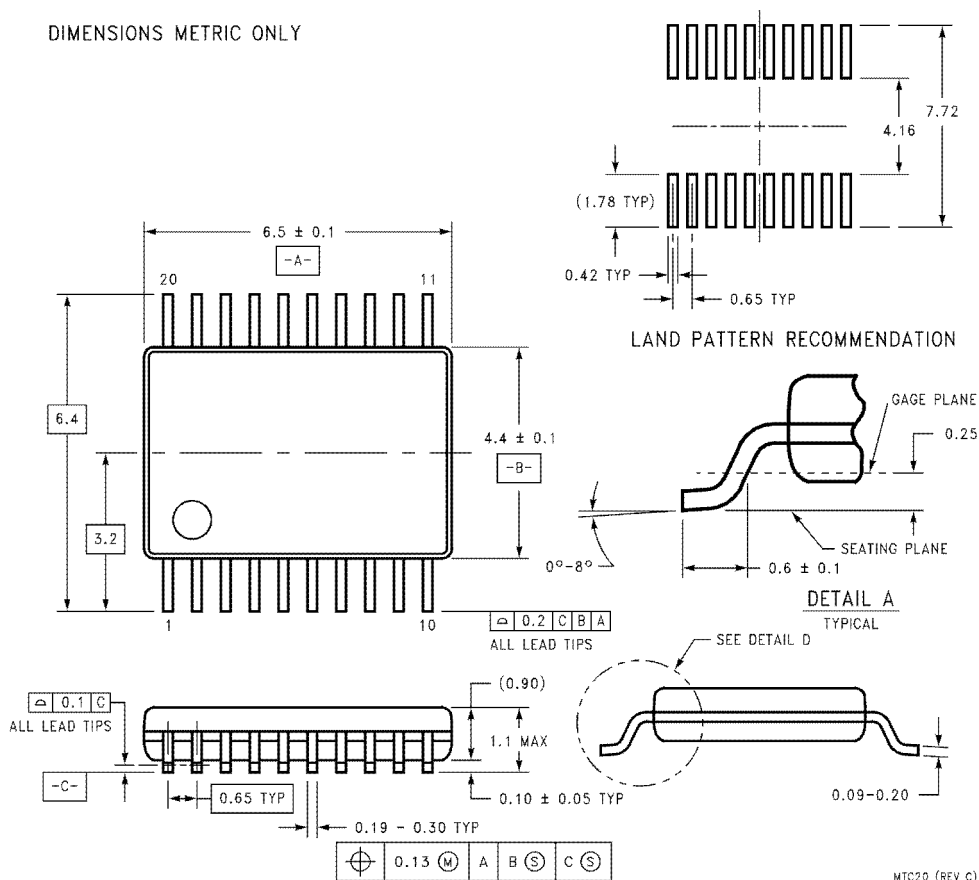

20-Lead Molded Thin Shrink Small Outline Package, JEDEC
Order Number 74LVT240MTC or 74LVT240MTCX
NS Package Number MTC20

LIFE SUPPORT POLICY

FAIRCHILD'S PRODUCTS ARE NOT AUTHORIZED FOR USE AS CRITICAL COMPONENTS IN LIFE SUPPORT DEVICES OR SYSTEMS WITHOUT THE EXPRESS WRITTEN APPROVAL OF THE PRESIDENT OF FAIRCHILD SEMICONDUCTOR CORPORATION. As used herein:

1. Life support devices or systems are devices or systems which, (a) are intended for surgical implant into the body, or (b) support or sustain life, and (c) whose failure to perform when properly used in accordance with instructions for use provided in the labeling, can be reasonably expected to result in a significant injury to the user.
2. A critical component in any component of a life support device or system whose failure to perform can be reasonably expected to cause the failure of the life support device or system, or to affect its safety or effectiveness.

Fairchild Corporation
 Americas
 Tel: 1-800-272-9959
 Fax: 1-800-737-7018
 Email: support@nsc.com
 www.fairchildsemi.com

Fairchild Europe
 Fax: +49 (0) 1 80-530 85 86
 Email: europe.support@nsc.com
 Deutsch Tel: +49 (0) 1 80-530 85 85
 English Tel: +49 (0) 1 80-532 78 32
 Français Tel: +49 (0) 1 80-532 93 58
 Italiano Tel: +49 (0) 1 80-534 16 80

Fairchild Hong Kong Ltd.
 13th Floor, Straight Block,
 Ocean Centre, 5 Canton Rd.
 Tsimshatsui, Kowloon
 Hong Kong
 Tel: (852) 2737-1600
 Fax: (852) 2736-9960

National Semiconductor Japan Ltd.
 Tel: 81-3-5620-6175
 Fax: 81-3-5620-6179