

74LV123

Dual retriggerable monostable multivibrator with reset

Rev. 8 — 4 March 2016

Product data sheet

1. General description

The 74LV123 is a low-voltage Si-gate CMOS device and is pin and function compatible with the 74HC123; 74HCT123. It is a dual retriggerable monostable multivibrator which uses three methods to control the output pulse width:

1. The basic pulse time is programmed by the selection of an external resistor (R_{EXT}) and capacitor (C_{EXT}). These are normally connected as shown in [Figure 9](#).
2. Once triggered, the basic output pulse width may be extended by retriggering the gated active LOW-going edge input ($n\bar{A}$) or the active HIGH-going edge input (nB). By repeating this process, the output pulse period ($nQ = \text{HIGH}$, $n\bar{Q} = \text{LOW}$) can be made as long as desired (see [Figure 12](#)).
3. Alternatively, an output delay can be terminated at any time by a LOW-going edge on input $n\bar{RD}$, which also inhibits the triggering (see [Figure 13](#)).

Schmitt-trigger action in the $n\bar{A}$ and nB inputs makes the circuit highly tolerant of slower input rise and fall times.

2. Features and benefits

- Optimized for low-voltage applications: 1.0 V to 5.5 V
- Accepts TTL input levels between $V_{CC} = 2.7 \text{ V}$ and $V_{CC} = 3.6 \text{ V}$
- Typical output ground bounce: $< 0.8 \text{ V}$ at $V_{CC} = 3.3 \text{ V}$ and $T_{amb} = 25 \text{ }^\circ\text{C}$
- Typical HIGH-level output voltage (V_{OH}) undershoot: $> 2 \text{ V}$ at $V_{CC} = 3.3 \text{ V}$ and $T_{amb} = 25 \text{ }^\circ\text{C}$
- DC triggered from active HIGH or active LOW inputs
- Retriggerable for very long pulses up to 100 % duty factor
- Direct reset terminates output pulses
- Schmitt-trigger action on all inputs except for the reset input

3. Ordering information

Table 1. Ordering information

Type number	Package			Version
	Temperature range	Name	Description	
74LV123D	-40 °C to +125 °C	SO16	plastic small outline package; 16 leads; body width 3.9 mm	SOT109-1
74LV123DB	-40 °C to +125 °C	SSOP16	plastic shrink small outline package; 16 leads; body width 5.3 mm	SOT338-1
74LV123PW	-40 °C to +125 °C	TSSOP16	plastic thin shrink small outline package; 16 leads; body width 4.4 mm	SOT403-1
74LV123BQ	-40 °C to +125 °C	DHVQFN16	plastic dual in-line compatible thermal enhanced very thin quad flat package; no leads; 16 terminals; body 2.5 × 3.5 × 0.85 mm	SOT763-1

4. Functional diagram

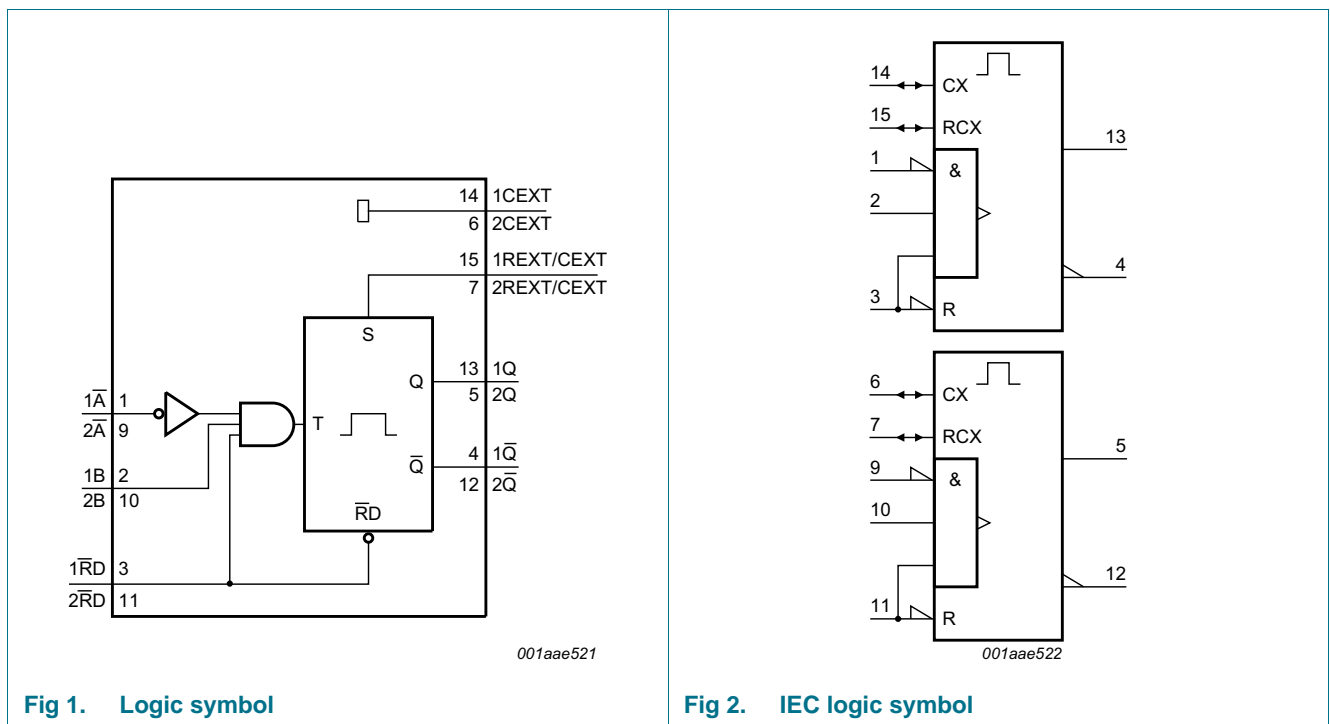

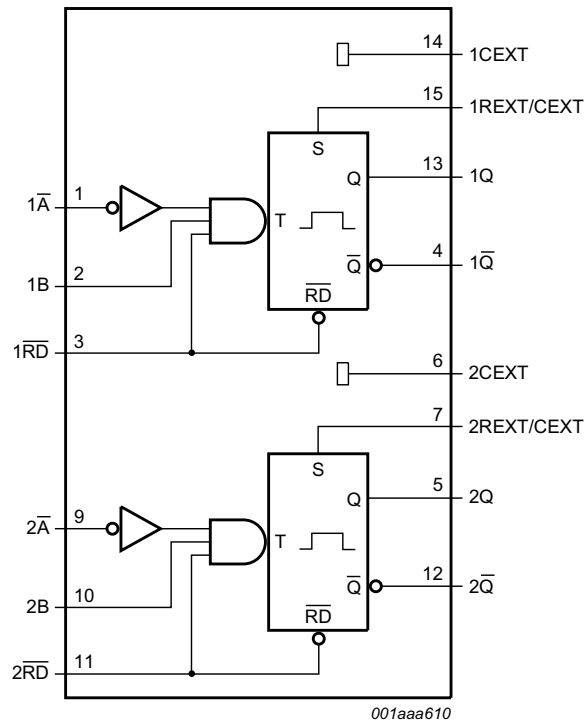

Fig 3. Functional diagram

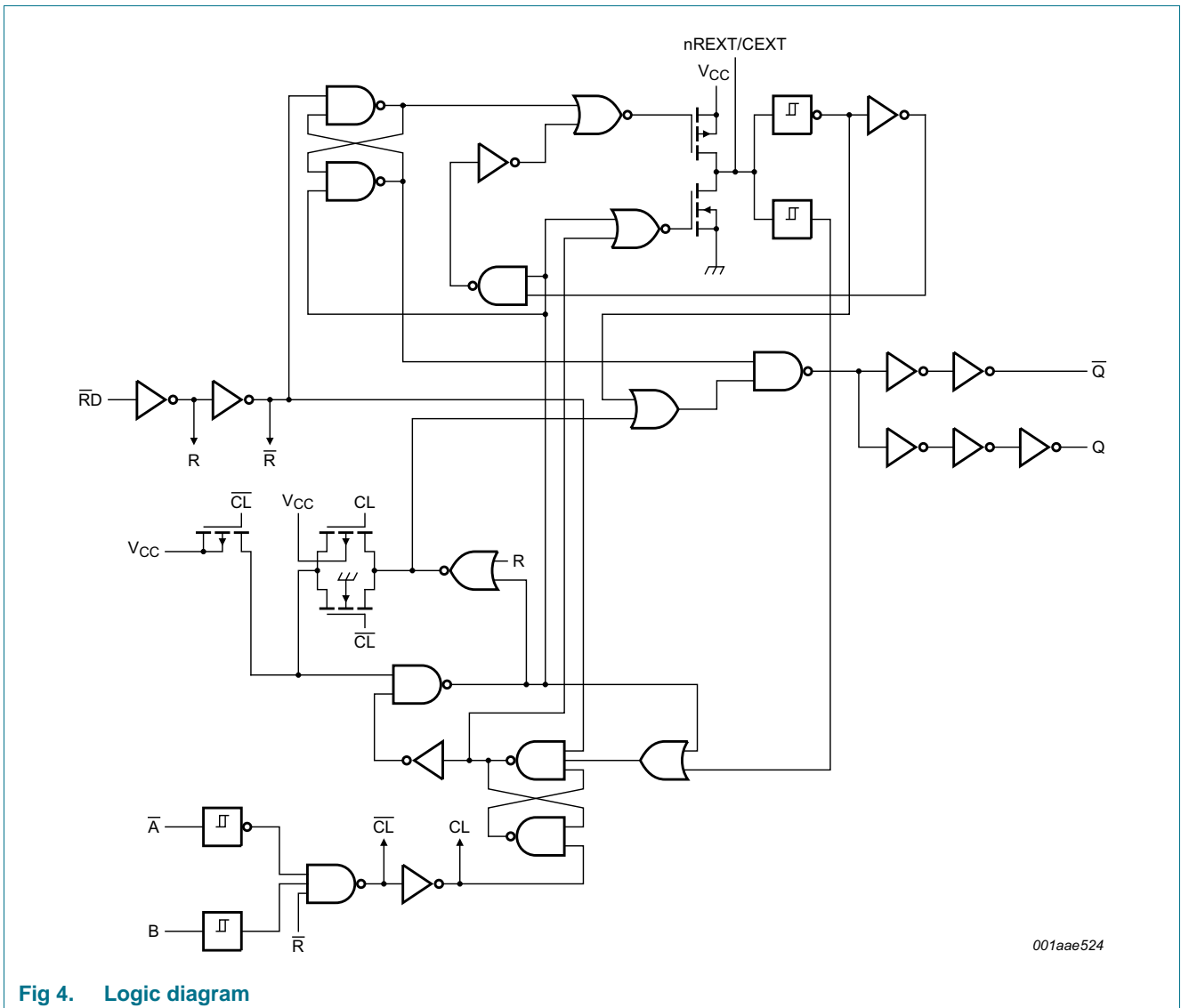
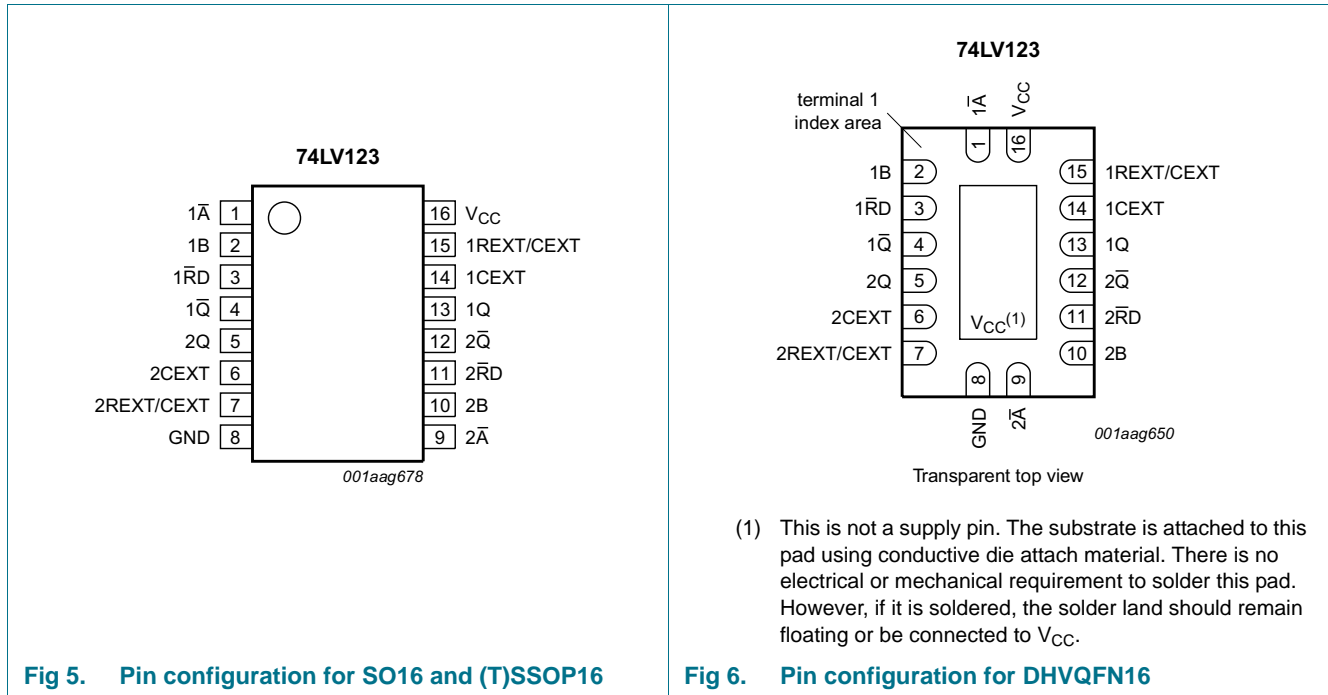

Fig 4. Logic diagram

5. Pinning information

5.1 Pinning









5.2 Pin description

Table 2. Pin description

Symbol	Pin	Description
$1\bar{A}$	1	negative-edge triggered input 1
1B	2	positive-edge triggered input 1
$1\bar{RD}$	3	direct reset LOW and positive-edge triggered input 1
$1\bar{Q}$	4	active LOW output 1
2Q	5	active HIGH output 2
2CEXT	6	external capacitor connection 2
2REXT/CEXT	7	external resistor and capacitor connection 2
GND	8	ground (0 V)
$2\bar{A}$	9	negative-edge triggered input 2
2B	10	positive-edge triggered input 2
$2\bar{RD}$	11	direct reset LOW and positive-edge triggered input 2
$2\bar{Q}$	12	active LOW output 2
1Q	13	active HIGH output 1
1CEXT	14	external capacitor connection 1
1REXT/CEXT	15	external resistor and capacitor connection 1
V_{CC}	16	supply voltage

6. Functional description

Table 3. Function table^[1]

Input			Output	
nRD	nA	nB	nQ	nQ
L	X	X	L	H
X	H	X	L ^[2]	H ^[2]
X	X	L	L ^[2]	H ^[2]
H	L	↑		
H	↓	H		
↑	L	H		

- [1] H = HIGH voltage level;
 L = LOW voltage level;
 X = don't care;
 ↑ = LOW-to-HIGH transition;
 ↓ = HIGH-to-LOW transition;

 = one HIGH level output pulse

 = one LOW level output pulse

- [2] If the monostable multivibrator was triggered before this condition was established, the pulse will continue as programmed.

7. Limiting values

Table 4. Limiting values

In accordance with the Absolute Maximum Rating System (IEC 60134). Voltages are referenced to GND (ground = 0 V).

Symbol	Parameter	Conditions	Min	Max	Unit
V_{CC}	supply voltage		-0.5	+7	V
I_{IK}	input clamping current	$V_I < -0.5\text{ V}$ or $V_I > V_{CC} + 0.5\text{ V}$ [1]	-	± 20	mA
I_{OK}	output clamping current	$V_O < -0.5\text{ V}$ or $V_O > V_{CC} + 0.5\text{ V}$ [1]	-	± 50	mA
I_O	output current	except for pins nREXT/CEXT; $V_O = -0.5\text{ V}$ to $(V_{CC} + 0.5\text{ V})$ [1]	-	± 25	mA
I_{CC}	supply current		-	+50	mA
I_{GND}	ground current		-50	-	mA
T_{stg}	storage temperature		-65	+150	°C
P_{tot}	total power dissipation	$T_{amb} = -40\text{ °C}$ to $+125\text{ °C}$			
		SO16 package [2]	-	500	mW
		SSOP16 package [3]	-	500	mW
		TSSOP16 package [3]	-	500	mW
		DHVQFN16 package [4]	-	500	mW

[1] The input and output voltage ratings may be exceeded if the input and output current ratings are observed.

[2] For SO16 package: P_{tot} derates linearly with 8 mW/K above 70 °C.

[3] For SSOP16 and TSSOP16 packages: P_{tot} derates linearly with 5.5 mW/K above 60 °C.

[4] For DHVQFN16 package: P_{tot} derates linearly with 4.5 mW/K above 60 °C.

8. Recommended operating conditions

Table 5. Recommended operating conditions

Symbol	Parameter	Conditions	Min	Typ	Max	Unit
V_{CC}	supply voltage	[1]	1.0	3.3	5.5	V
V_I	input voltage		0	-	V_{CC}	V
V_O	output voltage		0	-	V_{CC}	V
T_{amb}	ambient temperature	in free air	-40	+25	+125	°C
$\Delta t/\Delta V$	input transition rise and fall rate	$V_{CC} = 1.0\text{ V}$ to 2.0 V [2]	-	-	500	ns/V
		$V_{CC} = 2.0\text{ V}$ to 2.7 V	-	-	200	ns/V
		$V_{CC} = 2.7\text{ V}$ to 3.6 V	-	-	100	ns/V
		$V_{CC} = 3.6\text{ V}$ to 5.5 V	-	-	50	ns/V

[1] The 74LV123 is guaranteed to function down to $V_{CC} = 1.0\text{ V}$ (input levels GND or V_{CC}); [Section 9 "Static characteristics"](#) are guaranteed from $V_{CC} = 1.2\text{ V}$ to $V_{CC} = 5.5\text{ V}$.

[2] Except for Schmitt-trigger inputs \overline{nA} and nB.

9. Static characteristics

Table 6. Static characteristics

At recommended operating conditions; voltages are referenced to GND (ground = 0 V).

Symbol	Parameter	Conditions	Min	Typ ^[1]	Max	Unit
T_{amb} = -40 °C to +85 °C						
V _{IH}	HIGH-level input voltage	V _{CC} = 1.2 V	0.9	-	-	V
		V _{CC} = 2.0 V	1.4	-	-	V
		V _{CC} = 2.7 V to 3.6 V	2.0	-	-	V
		V _{CC} = 4.5 V to 5.5 V	0.7 × V _{CC}	-	-	V
V _{IL}	LOW-level input voltage	V _{CC} = 1.2 V	-	-	0.3	V
		V _{CC} = 2.0 V	-	-	0.6	V
		V _{CC} = 2.7 V to 3.6 V	-	-	0.8	V
		V _{CC} = 4.5 V to 5.5 V	-	-	0.3 × V _{CC}	V
V _{OH}	HIGH-level output voltage	V _I = V _{IH} or V _{IL}				
		I _O = -100 μA; V _{CC} = 1.2 V	-	1.2	-	V
		I _O = -100 μA; V _{CC} = 2.0 V	1.8	2.0	-	V
		I _O = -100 μA; V _{CC} = 2.7 V	2.5	2.7	-	V
		I _O = -100 μA; V _{CC} = 3.0 V	2.8	3.0	-	V
		I _O = -100 μA; V _{CC} = 4.5 V	4.3	4.5	-	V
		I _O = -6 mA; V _{CC} = 3.0 V	2.40	2.82	-	V
		I _O = -12 mA; V _{CC} = 4.5 V	3.60	4.20	-	V
V _{OL}	LOW-level output voltage	V _I = V _{IH} or V _{IL}				
		I _O = 100 μA; V _{CC} = 1.2 V	-	0	-	V
		I _O = 100 μA; V _{CC} = 2.0 V	-	0	0.2	V
		I _O = 100 μA; V _{CC} = 2.7 V	-	0	0.2	V
		I _O = 100 μA; V _{CC} = 3.0 V	-	0	0.2	V
		I _O = 100 μA; V _{CC} = 4.5 V	-	0	0.2	V
		I _O = 6 mA; V _{CC} = 3.0 V	-	0.25	0.40	V
		I _O = 12 mA; V _{CC} = 4.5 V	-	0.35	0.55	V
I _I	input leakage current	V _I = V _{CC} or GND; V _{CC} = 5.5 V	-	-	1.0	μA
I _{CC}	supply current	V _I = V _{CC} or GND; I _O = 0 A; V _{CC} = 5.5 V	-	-	20.0	μA
ΔI _{CC}	additional supply current	V _I = V _{CC} - 0.6 V; V _{CC} = 2.7 V to 3.6 V	-	-	500	μA
C _I	input capacitance		-	3.5	-	pF

Table 6. Static characteristics ...continued

At recommended operating conditions; voltages are referenced to GND (ground = 0 V).

Symbol	Parameter	Conditions	Min	Typ ^[1]	Max	Unit
T_{amb} = -40 °C to +125 °C						
V _{IH}	HIGH-level input voltage	V _{CC} = 1.2 V	0.9	-	-	V
		V _{CC} = 2.0 V	1.4	-	-	V
		V _{CC} = 2.7 V to 3.6 V	2.0	-	-	V
		V _{CC} = 4.5 V to 5.5 V	0.7 × V _{CC}	-	-	V
V _{IL}	LOW-level input voltage	V _{CC} = 1.2 V	-	-	0.3	V
		V _{CC} = 2.0 V	-	-	0.6	V
		V _{CC} = 2.7 V to 3.6 V	-	-	0.8	V
		V _{CC} = 4.5 V to 5.5 V	-	-	0.3 × V _{CC}	V
V _{OH}	HIGH-level output voltage	V _I = V _{IH} or V _{IL}				
		I _O = -100 μA; V _{CC} = 1.2 V	-	-	-	V
		I _O = -100 μA; V _{CC} = 2.0 V	1.8	-	-	V
		I _O = -100 μA; V _{CC} = 2.7 V	2.5	-	-	V
		I _O = -100 μA; V _{CC} = 3.0 V	2.8	-	-	V
		I _O = -100 μA; V _{CC} = 4.5 V	4.3	-	-	V
		I _O = -6 mA; V _{CC} = 3.0 V	2.2	-	-	V
I _O = -12 mA; V _{CC} = 4.5 V	3.5	-	-	V		
V _{OL}	LOW-level output voltage	V _I = V _{IH} or V _{IL}				
		I _O = 100 μA; V _{CC} = 1.2 V	-	-	-	V
		I _O = 100 μA; V _{CC} = 2.0 V	-	-	0.2	V
		I _O = 100 μA; V _{CC} = 2.7 V	-	-	0.2	V
		I _O = 100 μA; V _{CC} = 3.0 V	-	-	0.2	V
		I _O = 100 μA; V _{CC} = 4.5 V	-	-	0.2	V
		I _O = 6 mA; V _{CC} = 3.0 V	-	-	0.5	V
I _O = 12 mA; V _{CC} = 4.5 V	-	-	0.65	V		
I _I	input leakage current	V _I = V _{CC} or GND; V _{CC} = 5.5 V	-	-	1.0	μA
I _{CC}	supply current	V _I = V _{CC} or GND; I _O = 0 A; V _{CC} = 5.5 V	-	-	160	μA
ΔI _{CC}	additional supply current	V _I = V _{CC} - 0.6 V; V _{CC} = 2.7 V to 3.6 V	-	-	850	μA

[1] All typical values are measured at T_{amb} = 25 °C.

10. Dynamic characteristics

Table 7. Dynamic characteristics

$GND = 0\text{ V}$; $t_r = t_f \leq 2.5\text{ ns}$; for test circuit see [Figure 8](#).

Symbol	Parameter	Conditions	-40 °C to +85 °C			-40 °C to +125 °C		Unit
			Min	Typ ^[1]	Max	Min	Max	
Propagation delay; see Figure 7								
t_{pd}	propagation delay	\overline{nRD} , \overline{nA} and nB to \overline{nQ} [2]						
		$V_{CC} = 1.2\text{ V}$	-	120	-	-	-	ns
		$V_{CC} = 2.0\text{ V}$	-	40	76	-	92	ns
		$V_{CC} = 2.7\text{ V}$	-	30	56	-	68	ns
		$V_{CC} = 3.0\text{ V to }3.6\text{ V}$	-	25	48	-	57	ns
		$V_{CC} = 4.5\text{ V to }5.5\text{ V}$	-	18	40	-	46	ns
		\overline{nRD} to nQ (reset) [2]						
		$V_{CC} = 1.2\text{ V}$	-	100	-	-	-	ns
		$V_{CC} = 2.0\text{ V}$	-	30	57	-	68	ns
		$V_{CC} = 2.7\text{ V}$	-	23	43	-	51	ns
		$V_{CC} = 3.0\text{ V to }3.6\text{ V}$	-	20	38	-	45	ns
		$V_{CC} = 4.5\text{ V to }5.5\text{ V}$	-	14	31	-	36	ns
Inputs nA, nB and nRD; see Figure 7								
t_w	pulse width	$\overline{nA} = \text{LOW}$						
		$V_{CC} = 2.0\text{ V}$	30	5	-	40	-	ns
		$V_{CC} = 2.7\text{ V}$	25	3.5	-	30	-	ns
		$V_{CC} = 3.0\text{ V to }3.6\text{ V}$	20	3.0	-	25	-	ns
		$V_{CC} = 4.5\text{ V to }5.5\text{ V}$	15	2.5	-	20	-	ns
		$nB = \text{HIGH}$						
		$V_{CC} = 2.0\text{ V}$	30	13	-	40	-	ns
		$V_{CC} = 2.7\text{ V}$	25	8	-	30	-	ns
		$V_{CC} = 3.0\text{ V to }3.6\text{ V}$	20	7	-	25	-	ns
		$V_{CC} = 4.5\text{ V to }5.5\text{ V}$	15	5	-	20	-	ns
		$\overline{nRD} = \text{LOW}$; see Figure 13						
		$V_{CC} = 2.0\text{ V}$	35	6	-	45	-	ns
		$V_{CC} = 2.7\text{ V}$	30	5	-	40	-	ns
		$V_{CC} = 3.0\text{ V to }3.6\text{ V}$	25	4	-	30	-	ns
		$V_{CC} = 4.5\text{ V to }5.5\text{ V}$	20	3	-	25	-	ns
t_{trig}	retrigger time	nB to \overline{nA} ; see Figure 12						
		$V_{CC} = 2.0\text{ V}$	-	70	-	-	-	ns
		$V_{CC} = 2.7\text{ V}$	-	55	-	-	-	ns
		$V_{CC} = 3.0\text{ V to }3.6\text{ V}$	-	45	-	-	-	ns
		$V_{CC} = 4.5\text{ V to }5.5\text{ V}$	-	40	-	-	-	ns

Table 7. Dynamic characteristics ...continued
 $GND = 0\text{ V}$; $t_r = t_f \leq 2.5\text{ ns}$; for test circuit see [Figure 8](#).

Symbol	Parameter	Conditions	-40 °C to +85 °C			-40 °C to +125 °C		Unit
			Min	Typ ^[1]	Max	Min	Max	
Outputs; nQ = LOW and nQ = HIGH, see Figure 7								
t _w	pulse width	C _{EXT} = 100 nF; R _{EXT} = 10 kΩ						
		V _{CC} = 2.0 V	-	470	-	-	-	ns
		V _{CC} = 2.7 V	-	460	-	-	-	ns
		V _{CC} = 3.0 V to 3.6 V	-	450	-	-	-	ns
		V _{CC} = 4.5 V to 5.5 V	-	430	-	-	-	ns
		C _{EXT} = 0 pF; R _{EXT} = 5 kΩ						
		V _{CC} = 2.0 V	-	100	-	-	-	ns
		V _{CC} = 2.7 V	-	90	-	-	-	ns
		V _{CC} = 3.0 V to 3.6 V	-	80	-	-	-	ns
V _{CC} = 4.5 V to 5.5 V	-	70	-	-	-	ns		
External components								
R _{EXT}	external resistance	see Figure 11 ^[3]						
		V _{CC} = 1.2 V	10	-	1000	-	-	kΩ
		V _{CC} = 2.0 V	5	-	1000	-	-	kΩ
		V _{CC} = 2.7 V	3	-	1000	-	-	kΩ
		V _{CC} = 3.0 V to 3.6 V	2	-	1000	-	-	kΩ
		V _{CC} = 4.5 V to 5.5 V	2	-	1000	-	-	kΩ
C _{EXT}	external capacitance	see Figure 11 ^[3] ^[4]						
		V _{CC} = 1.2 V	-	-	-	-	-	pF
		V _{CC} = 2.0 V	-	-	-	-	-	pF
		V _{CC} = 2.7 V	-	-	-	-	-	pF
		V _{CC} = 3.0 V to 3.6 V	-	-	-	-	-	pF
		V _{CC} = 4.5 V to 5.5 V	-	-	-	-	-	pF
Dynamic power dissipation								
C _{PD}	power dissipation capacitance	V _{CC} = 3.3 V; V _I = GND to V _{CC} ^[5]	-	60	-	-	-	pF

[1] All typical values are measured at T_{amb} = 25 °C and nominal supply values (V_{CC} = 3.3 V and 5.0 V).

[2] t_{pd} is the same as t_{PLH} and t_{PHL}; C_{EXT} = 0 pF; R_{EXT} = 5 kΩ.

[3] For other R_{EXT} and C_{EXT} combinations see [Figure 11](#) and [Section 12.1.1 "Basic timing"](#).

[4] C_{EXT} has no limits.

[5] C_{PD} is used to determine the dynamic power dissipation (P_D in μW).

$P_D = C_{PD} \times V_{CC}^2 \times f_i \times N + \Sigma(C_L \times V_{CC}^2 \times f_o)$ where:

f_i = input frequency in MHz;

f_o = output frequency in MHz;

C_L = output load capacitance in pF;

V_{CC} = supply voltage in V;

N = number of inputs switching;

Σ(C_L × V_{CC}² × f_o) = sum of the outputs.

11. Waveforms

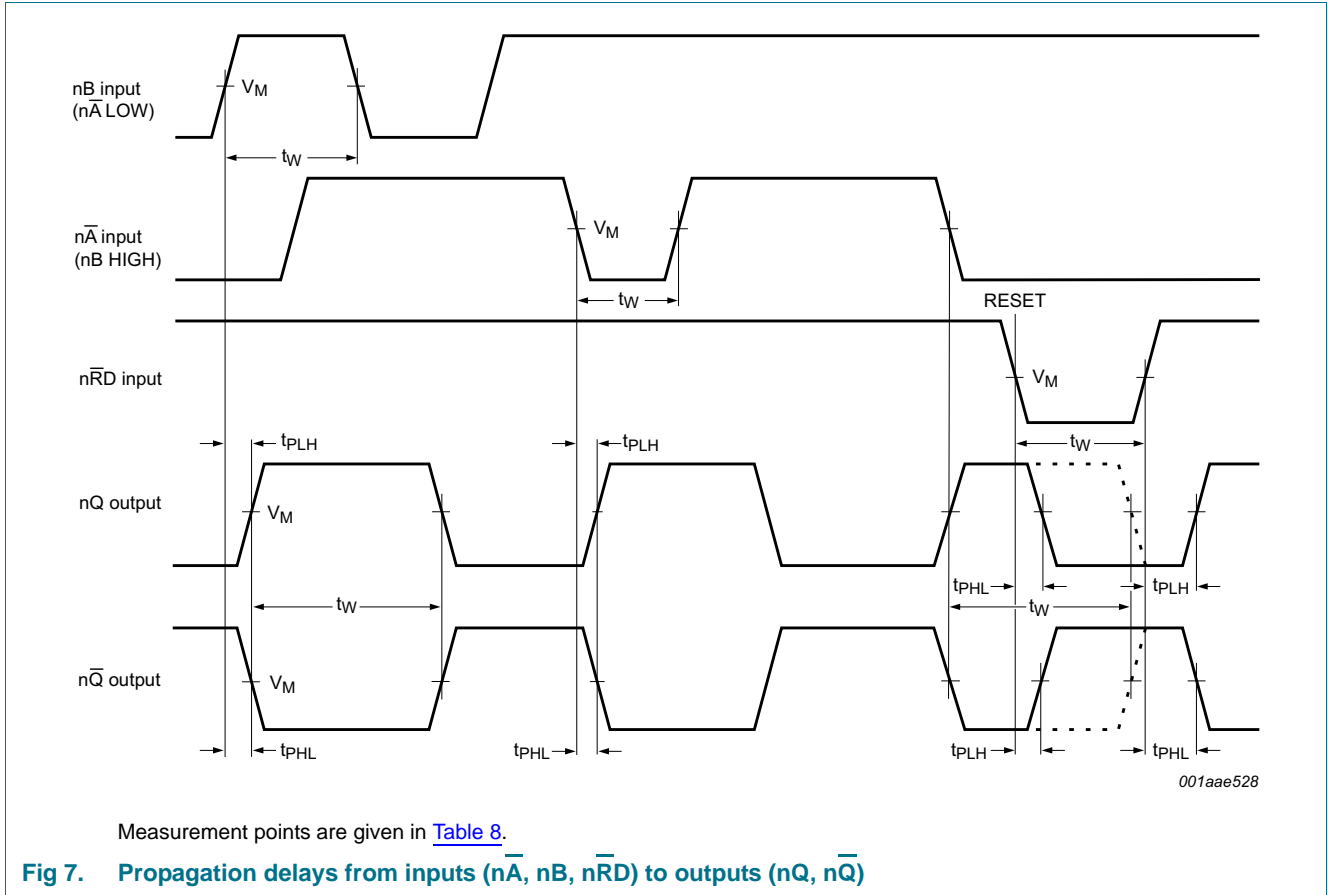

Table 8. Measurement points

V _{CC}	V _M
≥ 2.7 V	1.5 V
< 2.7 V	0.5 × V _{CC}

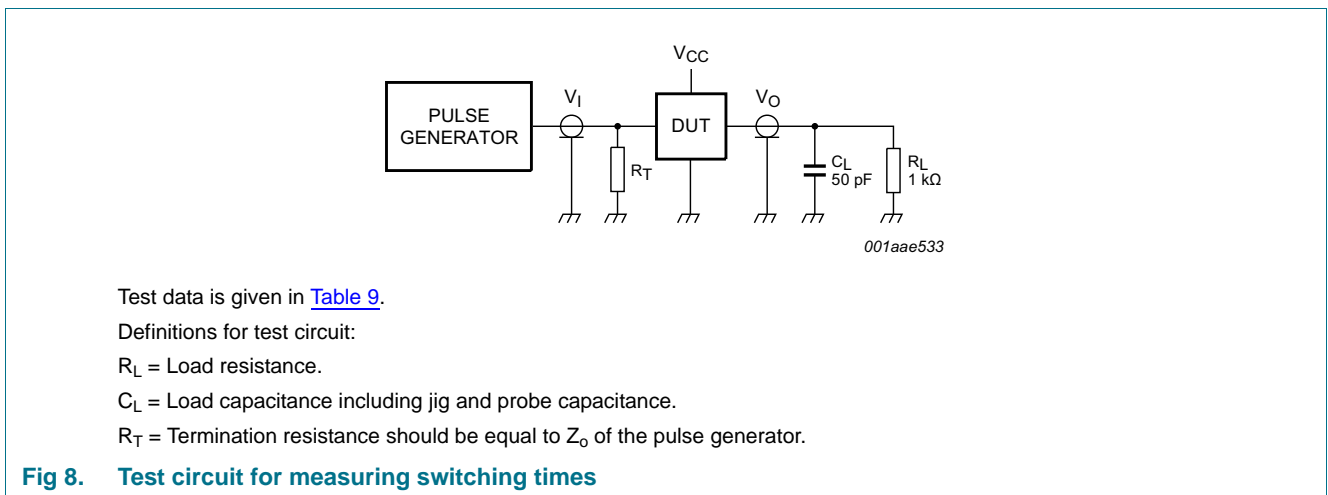

Table 9. Test data

Supply voltage	Input		Load		Test
V _{CC}	V _I	t _r , t _f	C _L	R _L	
< 2.7 V	V _{CC}	≤ 2.5 ns	50 pF	1 kΩ	t _{PHL} , t _{PLH}
2.7 V to 3.6 V	2.7 V	≤ 2.5 ns	50 pF	1 kΩ	t _{PHL} , t _{PLH}
≥ 4.5 V	V _{CC}	≤ 2.5 ns	50 pF	1 kΩ	t _{PHL} , t _{PLH}

12. Application information

12.1 Timing components

12.1.1 Basic timing

The basic output pulse width is essentially determined by the values of the external timing components R_{EXT} and C_{EXT}.

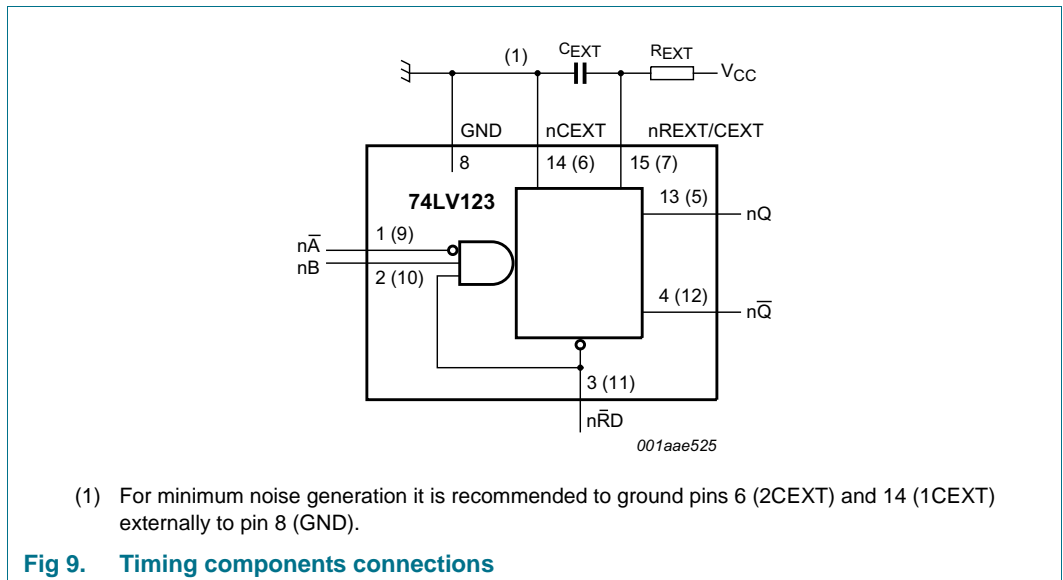

If C_{EXT} > 10 nF, the following formula is valid: t_W = K × R_{EXT} × C_{EXT} (typ.) where:

t_W = output pulse width in ns

R_{EXT} = external resistor in kΩ

C_{EXT} = external capacitor in pF

K = constant: this is 0.45 for V_{CC} = 5.0 V and 0.48 for V_{CC} = 2.0 V (see [Figure 10](#))

The inherent test jig and pin capacitance at pin 15 and pin 7 (nREXT/CEXT) is approximately 7 pF.

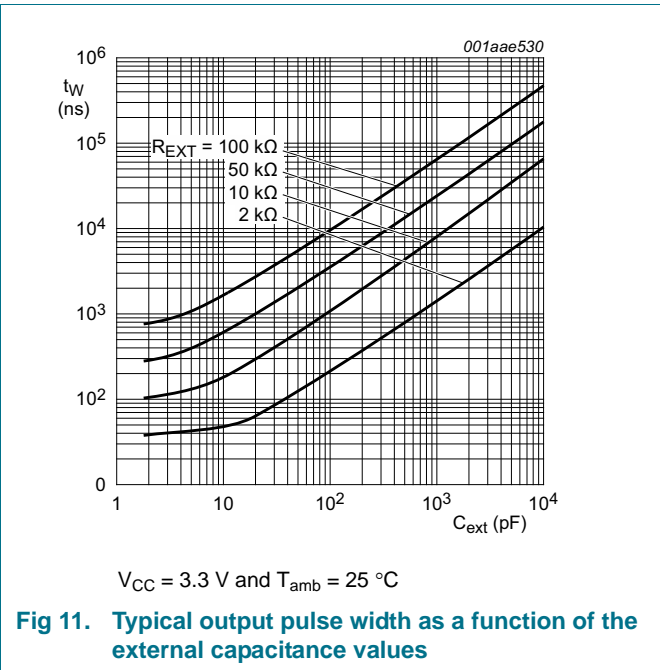
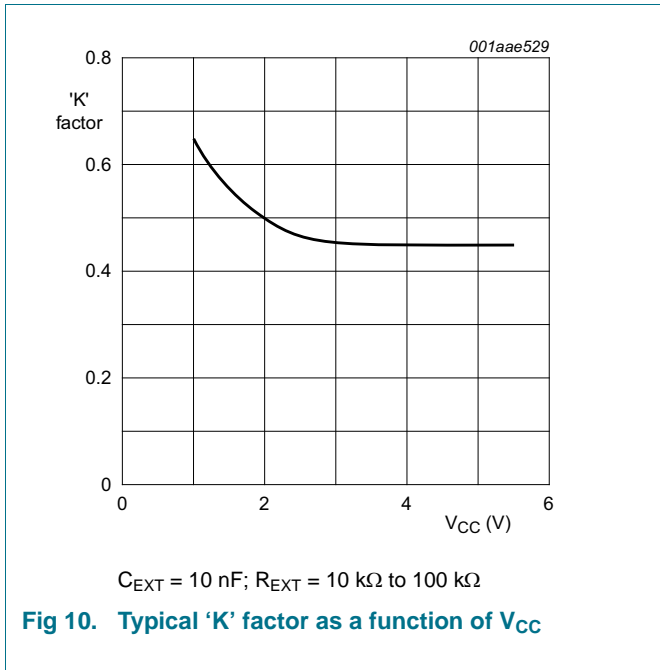

12.1.2 Retrigger timing

The time to retrigger the monostable multivibrator depends on the values of R_{EXT} and C_{EXT} . The output pulse width will only be extended when the time between the active going edges of the trigger pulses meets the minimum retrigger time. If $C_{EXT} > 10 \text{ pF}$, the next formula for the set-up time of a retrigger pulse is valid:

at $V_{CC} = 5.0 \text{ V}$: $t_{rtrig} = 30 + 0.19R_{EXT} \times C_{EXT}^{0.9} + 13 \times R_{EXT}^{1.05}$ (typ.)

at $V_{CC} = 3.0 \text{ V}$: $t_{rtrig} = 41 + 0.15R_{EXT} \times C_{EXT}^{0.9} \times 1 \times R_{EXT}$ (typ.)

where:

t_{rtrig} = retrigger time in ns

C_{EXT} = external capacitor in pF

R_{EXT} = external resistor in kΩ

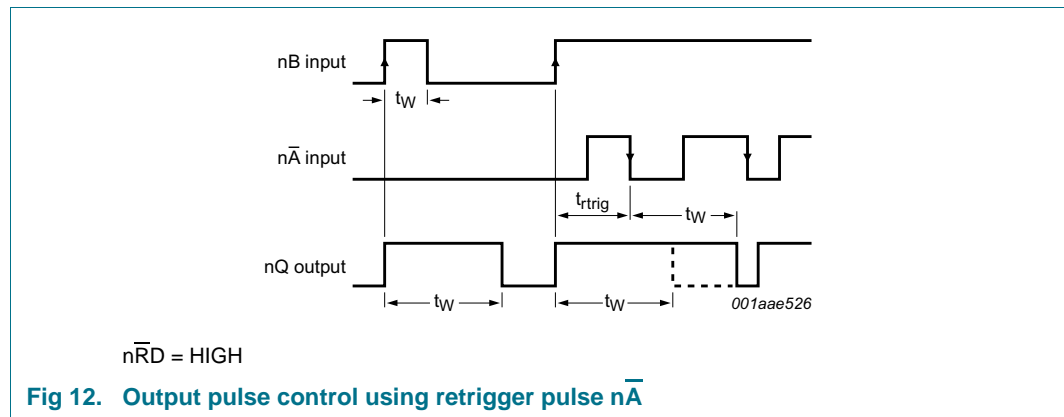

12.1.3 Reset timing

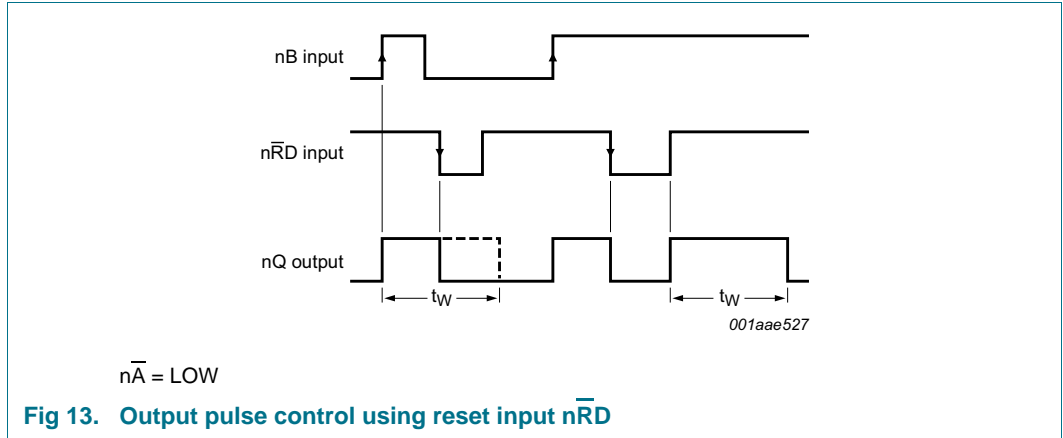

12.2 Power considerations

12.2.1 Power-up

When the monostable multivibrator is powered-up, it may produce an output pulse with a pulse width defined by the values of R_{EXT} and C_{EXT} . This output pulse can be eliminated using the RC circuit on pin \bar{nRD} shown in [Figure 14](#).

12.2.2 Power-down

A large capacitor (C_{EXT}) may cause problems when powering-down the monostable due to the energy stored in this capacitor. When a system containing this device is powered-down or a rapid decrease of V_{CC} to zero occurs, the monostable may sustain damage, due to the capacitor discharging through the input protection diodes. To avoid this possibility, connect a damping diode D_{EXT} (preferably a germanium or Schottky type diode) able to withstand large current surges - see [Figure 14](#).

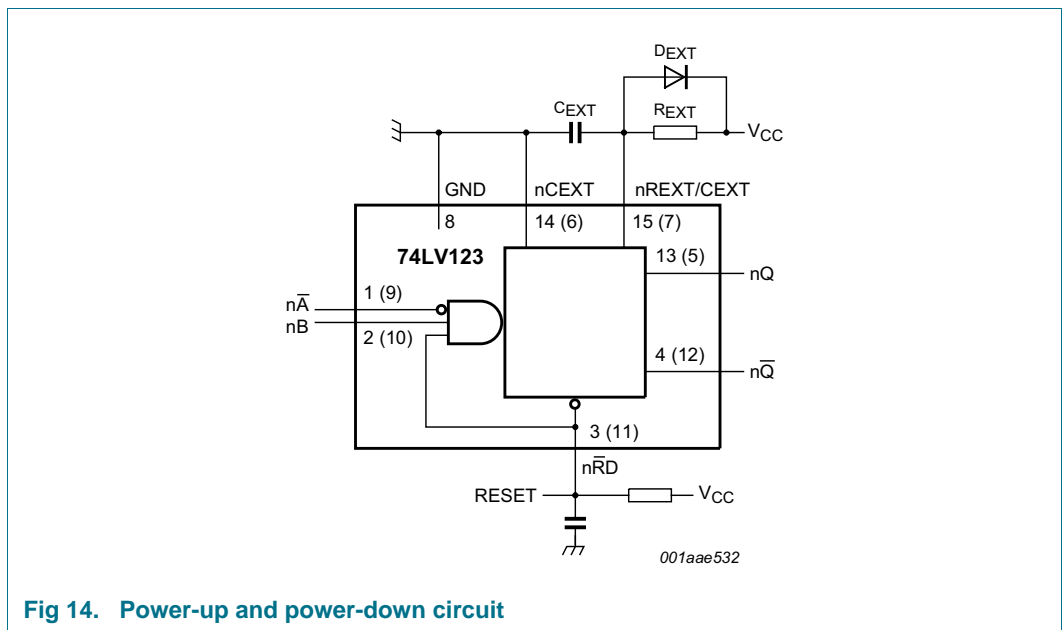

13. Package outline

SO16: plastic small outline package; 16 leads; body width 3.9 mm

SOT109-1

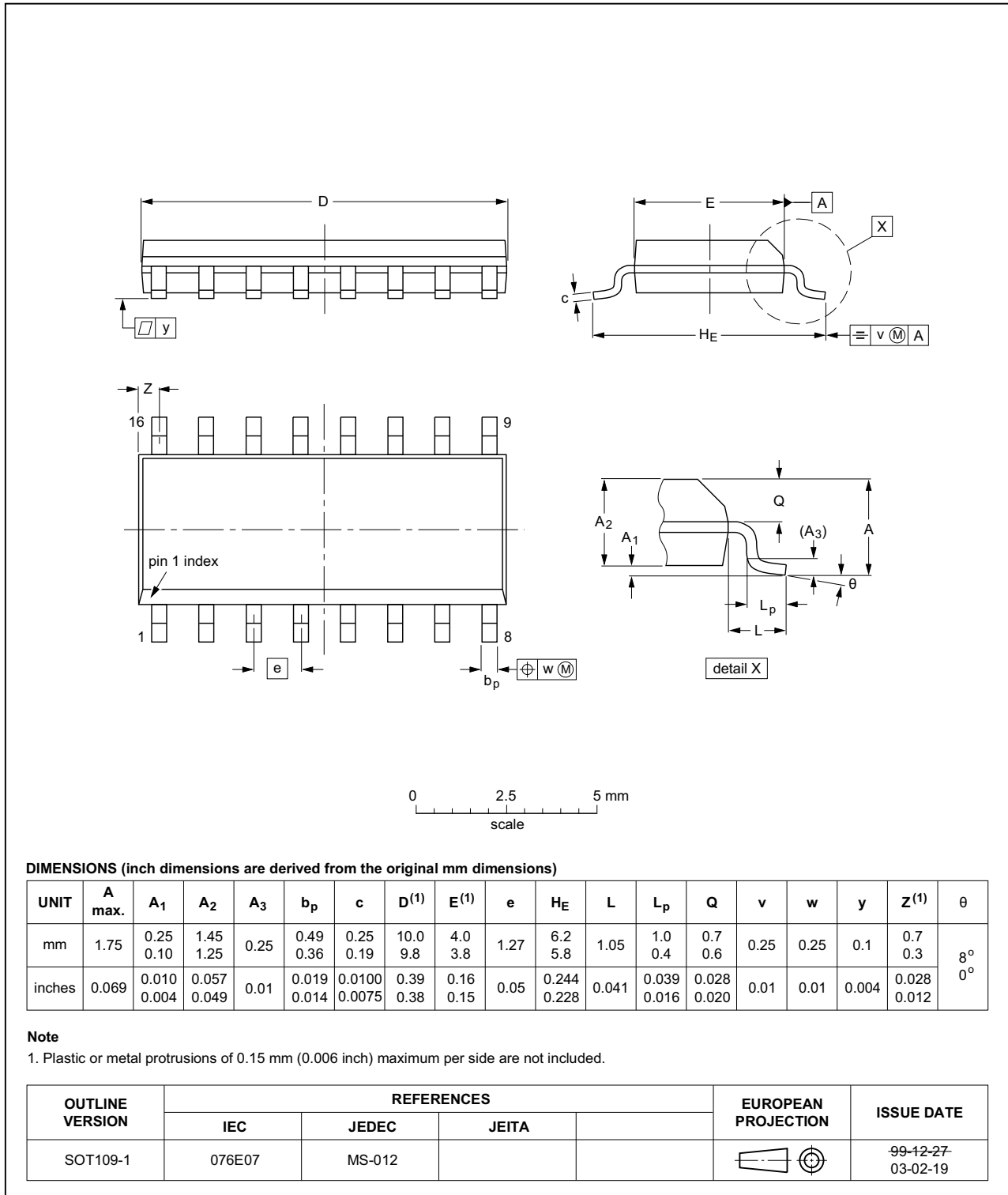

Fig 15. Package outline SOT109-1 (SO16)

SSOP16: plastic shrink small outline package; 16 leads; body width 5.3 mm

SOT338-1

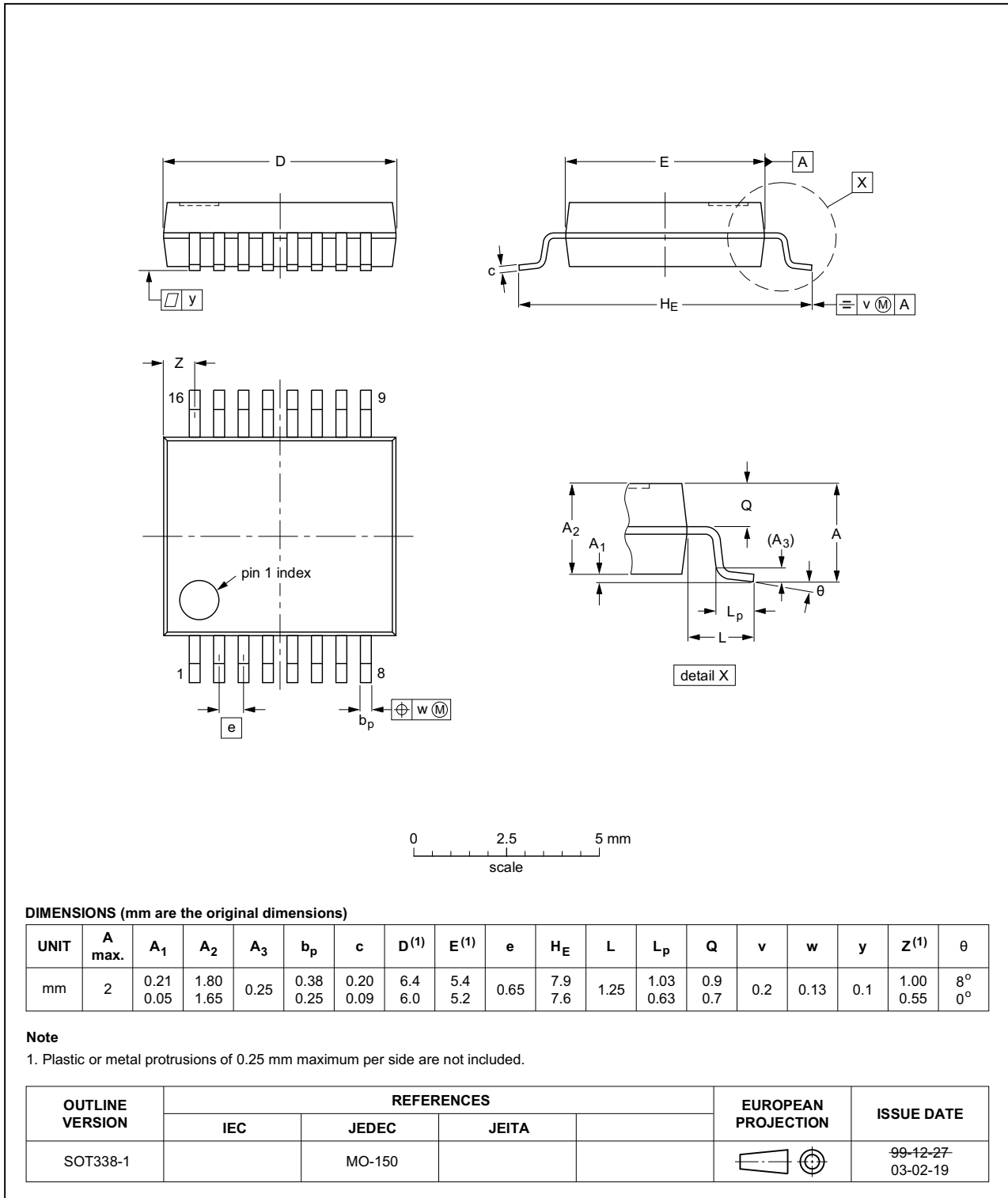

Fig 16. Package outline SOT338-1 (SSOP16)

TSSOP16: plastic thin shrink small outline package; 16 leads; body width 4.4 mm

SOT403-1

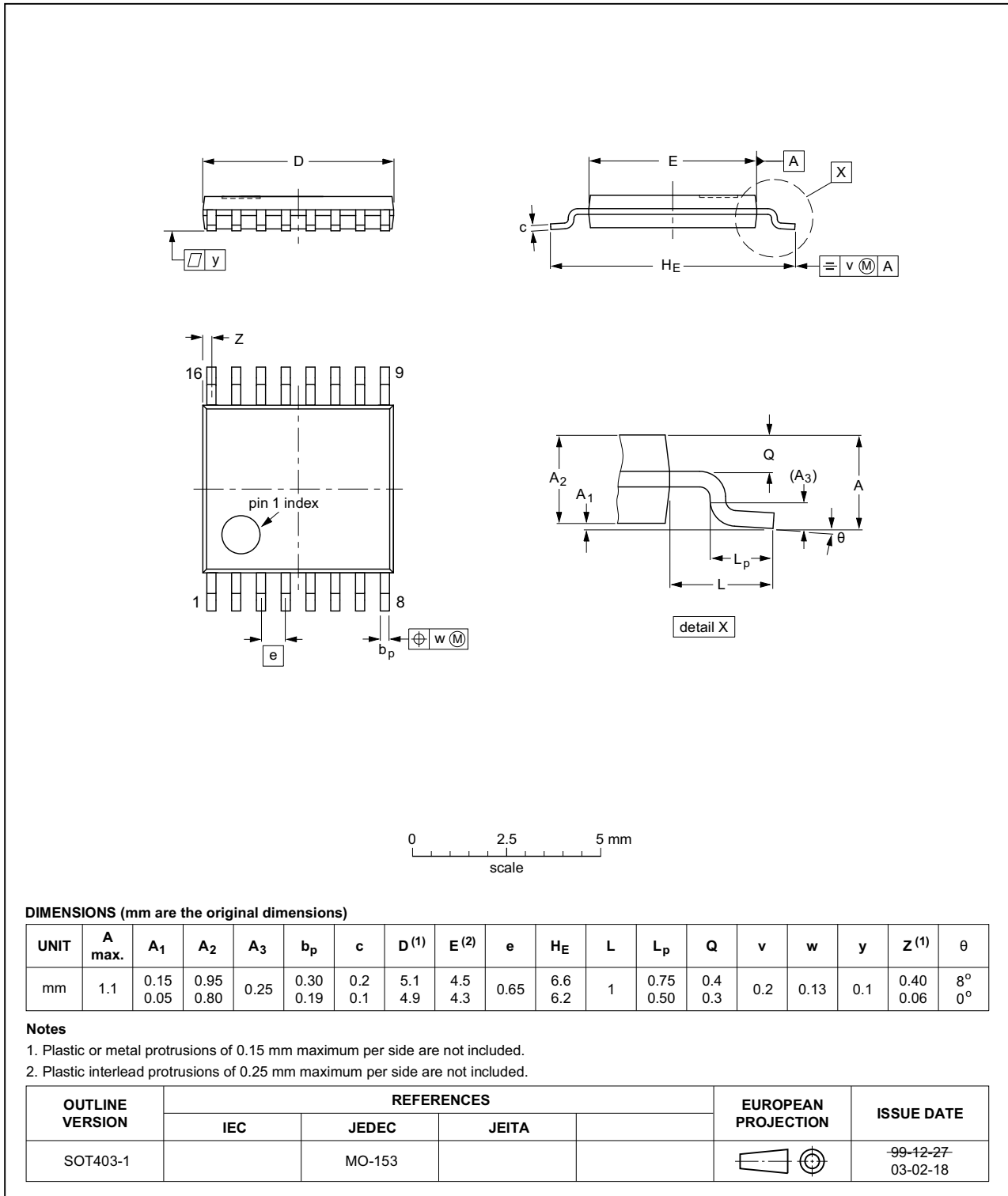

Fig 17. Package outline SOT403-1 (TSSOP16)

DHVQFN16: plastic dual in-line compatible thermal enhanced very thin quad flat package; no leads; 16 terminals; body 2.5 x 3.5 x 0.85 mm

SOT763-1

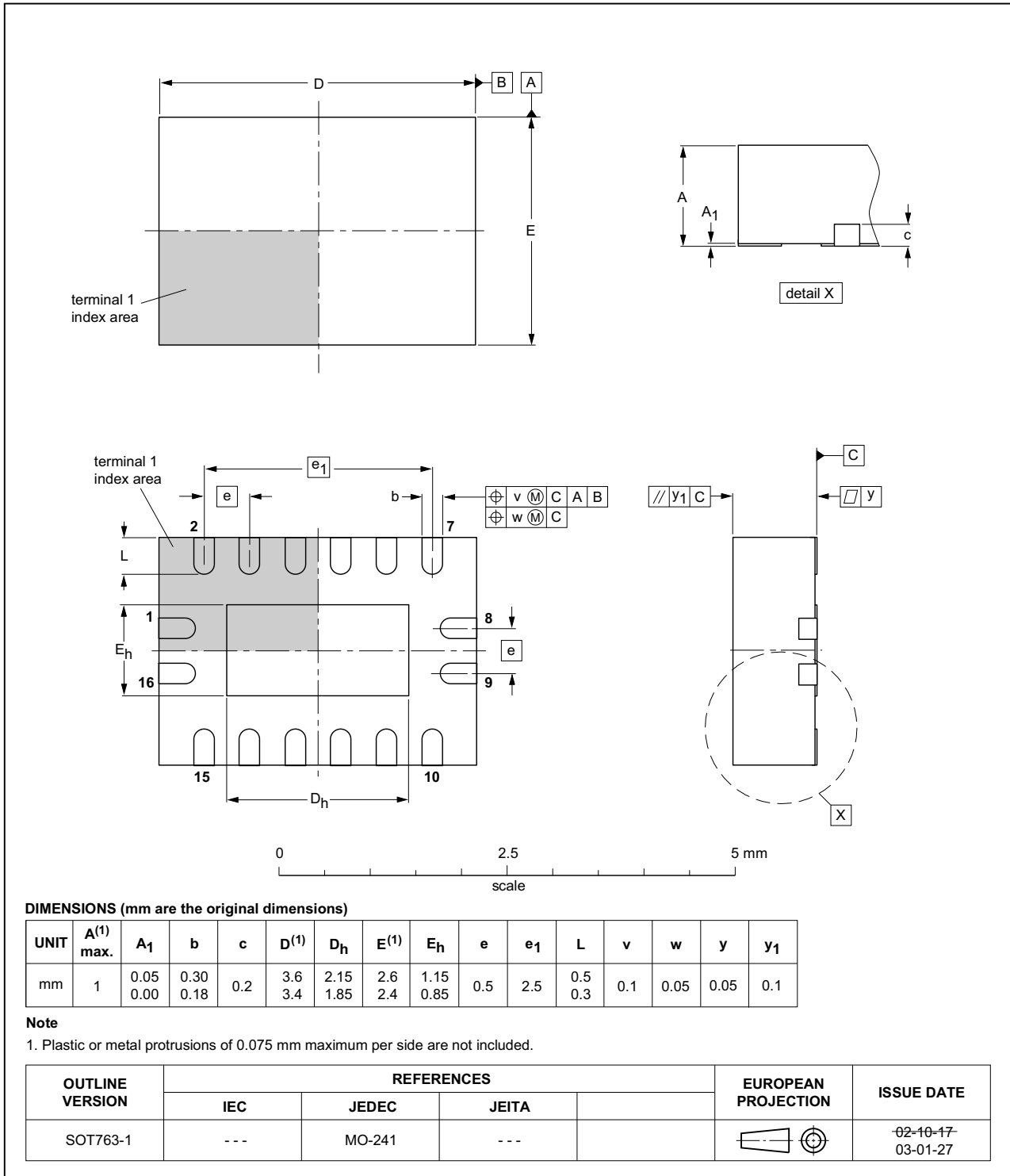

Fig 18. Package outline SOT763-1 (DHVQFN16)

14. Abbreviations

Table 10. Abbreviations

Acronym	Description
CMOS	Complementary Metal Oxide Semiconductor
DUT	Device Under Test

15. Revision history

Table 11. Revision history

Document ID	Release date	Data sheet status	Change notice	Supersedes
74LV123 v.8	20160304	Product data sheet	-	74LV123 v.7
Modifications:	<ul style="list-style-type: none"> Type numbers 74LV123N (SOT38-4) removed. 			
74LV123 v.7	20111212	Product data sheet	-	74LV123 v.6
Modifications:	<ul style="list-style-type: none"> Legal pages updated. 			
74LV123 v.6	20110826	Product data sheet	-	74LV123 v.5
74LV123 v.5	20071108	Product data sheet	-	74LV123 v.4
74LV123 v.4	20070919	Product specification	-	74LV123 v.3
74LV123 v.3	20030313	Product specification	-	74LV123 v.2
74LV123 v.2	19980420	Product specification	-	74LV123 v.1
74LV123 v.1	19970204	Product specification	-	-

16. Legal information

16.1 Data sheet status

Document status ^{[1][2]}	Product status ^[3]	Definition
Objective [short] data sheet	Development	This document contains data from the objective specification for product development.
Preliminary [short] data sheet	Qualification	This document contains data from the preliminary specification.
Product [short] data sheet	Production	This document contains the product specification.

[1] Please consult the most recently issued document before initiating or completing a design.

[2] The term 'short data sheet' is explained in section "Definitions".

[3] The product status of device(s) described in this document may have changed since this document was published and may differ in case of multiple devices. The latest product status information is available on the Internet at URL <http://www.nexperia.com>.

16.2 Definitions

Draft — The document is a draft version only. The content is still under internal review and subject to formal approval, which may result in modifications or additions. Nexperia does not give any representations or warranties as to the accuracy or completeness of information included herein and shall have no liability for the consequences of use of such information.

Short data sheet — A short data sheet is an extract from a full data sheet with the same product type number(s) and title. A short data sheet is intended for quick reference only and should not be relied upon to contain detailed and full information. For detailed and full information see the relevant full data sheet, which is available on request via the local Nexperia sales office. In case of any inconsistency or conflict with the short data sheet, the full data sheet shall prevail.

Product specification — The information and data provided in a Product data sheet shall define the specification of the product as agreed between Nexperia and its customer, unless Nexperia and customer have explicitly agreed otherwise in writing. In no event however, shall an agreement be valid in which the Nexperia product is deemed to offer functions and qualities beyond those described in the Product data sheet.

16.3 Disclaimers

Limited warranty and liability — Information in this document is believed to be accurate and reliable. However, Nexperia does not give any representations or warranties, expressed or implied, as to the accuracy or completeness of such information and shall have no liability for the consequences of use of such information. Nexperia takes no responsibility for the content in this document if provided by an information source outside of Nexperia.

In no event shall Nexperia be liable for any indirect, incidental, punitive, special or consequential damages (including - without limitation - lost profits, lost savings, business interruption, costs related to the removal or replacement of any products or rework charges) whether or not such damages are based on tort (including negligence), warranty, breach of contract or any other legal theory.

Notwithstanding any damages that customer might incur for any reason whatsoever, Nexperia's aggregate and cumulative liability towards customer for the products described herein shall be limited in accordance with the *Terms and conditions of commercial sale* of Nexperia.

Right to make changes — Nexperia reserves the right to make changes to information published in this document, including without limitation specifications and product descriptions, at any time and without notice. This document supersedes and replaces all information supplied prior to the publication hereof.

Suitability for use — Nexperia products are not designed, authorized or warranted to be suitable for use in life support, life-critical or safety-critical systems or equipment, nor in applications where failure or malfunction of a Nexperia product can reasonably be expected to result in personal injury, death or severe property or environmental damage. Nexperia and its suppliers accept no liability for inclusion and/or use of Nexperia products in such equipment or applications and therefore such inclusion and/or use is at the customer's own risk.

Applications — Applications that are described herein for any of these products are for illustrative purposes only. Nexperia makes no representation or warranty that such applications will be suitable for the specified use without further testing or modification.

Customers are responsible for the design and operation of their applications and products using Nexperia products, and Nexperia accepts no liability for any assistance with applications or customer product design. It is customer's sole responsibility to determine whether the Nexperia product is suitable and fit for the customer's applications and products planned, as well as for the planned application and use of customer's third party customer(s). Customers should provide appropriate design and operating safeguards to minimize the risks associated with their applications and products.

Nexperia does not accept any liability related to any default, damage, costs or problem which is based on any weakness or default in the customer's applications or products, or the application or use by customer's third party customer(s). Customer is responsible for doing all necessary testing for the customer's applications and products using Nexperia products in order to avoid a default of the applications and the products or of the application or use by customer's third party customer(s). Nexperia does not accept any liability in this respect.

Limiting values — Stress above one or more limiting values (as defined in the Absolute Maximum Ratings System of IEC 60134) will cause permanent damage to the device. Limiting values are stress ratings only and (proper) operation of the device at these or any other conditions above those given in the Recommended operating conditions section (if present) or the Characteristics sections of this document is not warranted. Constant or repeated exposure to limiting values will permanently and irreversibly affect the quality and reliability of the device.

Terms and conditions of commercial sale — Nexperia products are sold subject to the general terms and conditions of commercial sale, as published at <http://www.nexperia.com/profile/terms>, unless otherwise agreed in a valid written individual agreement. In case an individual agreement is concluded only the terms and conditions of the respective agreement shall apply. Nexperia hereby expressly objects to applying the customer's general terms and conditions with regard to the purchase of Nexperia products by customer.

No offer to sell or license — Nothing in this document may be interpreted or construed as an offer to sell products that is open for acceptance or the grant, conveyance or implication of any license under any copyrights, patents or other industrial or intellectual property rights.

Export control — This document as well as the item(s) described herein may be subject to export control regulations. Export might require a prior authorization from competent authorities.

Non-automotive qualified products — Unless this data sheet expressly states that this specific Nexperia product is automotive qualified, the product is not suitable for automotive use. It is neither qualified nor tested in accordance with automotive testing or application requirements. Nexperia accepts no liability for inclusion and/or use of non-automotive qualified products in automotive equipment or applications.

In the event that customer uses the product for design-in and use in automotive applications to automotive specifications and standards, customer (a) shall use the product without Nexperia's warranty of the product for such automotive applications, use and specifications, and (b) whenever customer uses the product for automotive applications beyond

Nexperia's specifications such use shall be solely at customer's own risk, and (c) customer fully indemnifies Nexperia for any liability, damages or failed product claims resulting from customer design and use of the product for automotive applications beyond Nexperia's standard warranty and Nexperia's product specifications.

Translations — A non-English (translated) version of a document is for reference only. The English version shall prevail in case of any discrepancy between the translated and English versions.

16.4 Trademarks

Notice: All referenced brands, product names, service names and trademarks are the property of their respective owners.

17. Contact information

For more information, please visit: <http://www.nexperia.com>

For sales office addresses, please send an email to: salesaddresses@nexperia.com

18. Contents

1	General description	1
2	Features and benefits	1
3	Ordering information	2
4	Functional diagram	2
5	Pinning information	5
5.1	Pinning	5
5.2	Pin description	5
6	Functional description	6
7	Limiting values	7
8	Recommended operating conditions	7
9	Static characteristics	8
10	Dynamic characteristics	10
11	Waveforms	12
12	Application information	13
12.1	Timing components	13
12.1.1	Basic timing	13
12.1.2	Retrigger timing	14
12.1.3	Reset timing	15
12.2	Power considerations	15
12.2.1	Power-up	15
12.2.2	Power-down	15
13	Package outline	16
14	Abbreviations	20
15	Revision history	20
16	Legal information	21
16.1	Data sheet status	21
16.2	Definitions	21
16.3	Disclaimers	21
16.4	Trademarks	22
17	Contact information	22
18	Contents	23