

# 74HC151-Q100; 74HCT151-Q100

## 8-input multiplexer

Rev. 2 — 11 February 2013

Product data sheet

### 1. General description

The 74HC151-Q100; 74HCT151-Q100 are 8-bit multiplexer with eight binary inputs (I0 to I7), three select inputs (S0 to S2) and an enable input ( $\bar{E}$ ). One of the eight binary inputs is selected by the select inputs and routed to the complementary outputs (Y and  $\bar{Y}$ ). A HIGH on  $\bar{E}$  forces the output Y LOW and output  $\bar{Y}$  HIGH. Inputs also include clamp diodes. This enables the use of current limiting resistors to interface inputs to voltages in excess of  $V_{CC}$ .

This product has been qualified to the Automotive Electronics Council (AEC) standard Q100 (Grade 1) and is suitable for use in automotive applications.

### 2. Features and benefits

- Automotive product qualification in accordance with AEC-Q100 (Grade 1)
  - ◆ Specified from  $-40\text{ }^{\circ}\text{C}$  to  $+85\text{ }^{\circ}\text{C}$  and from  $-40\text{ }^{\circ}\text{C}$  to  $+125\text{ }^{\circ}\text{C}$
- Input levels:
  - ◆ For 74HC151-Q100: CMOS level
  - ◆ For 74HCT151-Q100: TTL level
- Low-power dissipation
- Non-inverting data path
- Specified in compliance with JEDEC standard no. 7A
- ESD protection:
  - ◆ MIL-STD-883, method 3015 exceeds 2000 V
  - ◆ HBM JESD22-A114F exceeds 2000 V
  - ◆ MM JESD22-A115-A exceeds 200 V (C = 200 pF, R = 0  $\Omega$ )
- Multiple package options

### 3. Ordering information

Table 1. Ordering information

Type number	Package			Version
	Temperature range	Name	Description	
74HC151D-Q100 74HCT151D-Q100	$-40\text{ }^{\circ}\text{C}$ to $+125\text{ }^{\circ}\text{C}$	SO16	plastic small outline package; 16 leads; body width 3.9 mm	SOT109-1
74HC151PW-Q100 74HCT151PW-Q100	$-40\text{ }^{\circ}\text{C}$ to $+125\text{ }^{\circ}\text{C}$	TSSOP16	plastic thin shrink small outline package; 16 leads; body width 4.4 mm	SOT403-1



4. Functional diagram

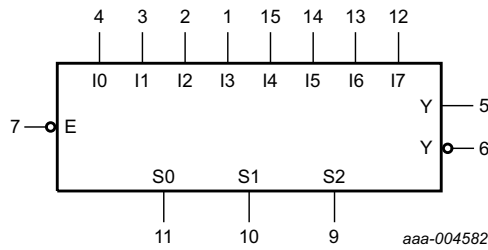

Fig 1. Logic symbol

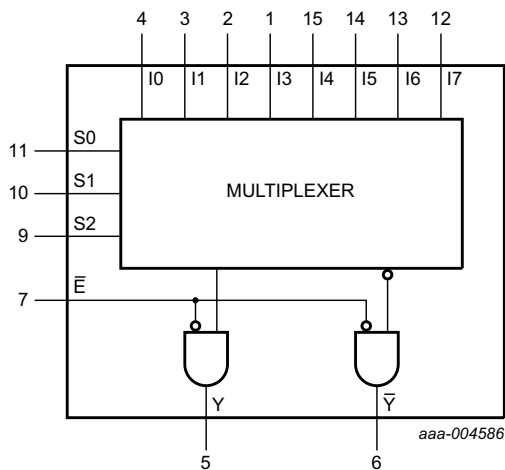

Fig 2. Functional diagram

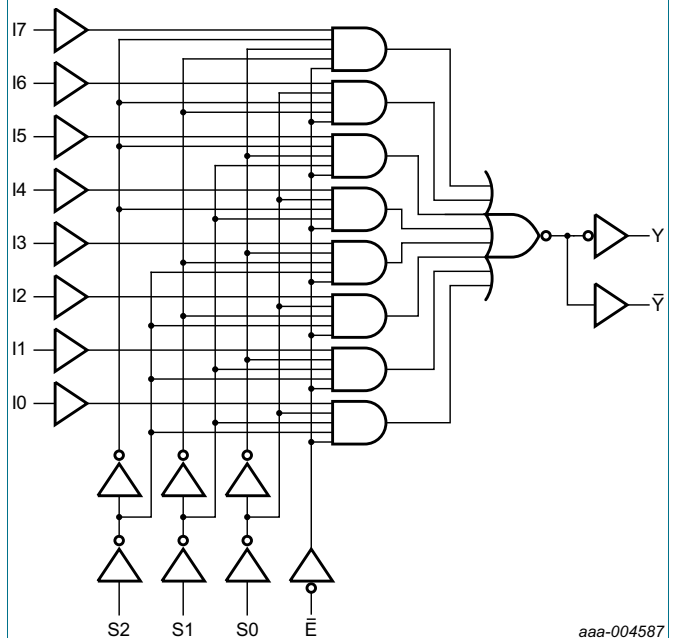

Fig 3. Logic diagram

## 5. Pinning information

### 5.1 Pinning

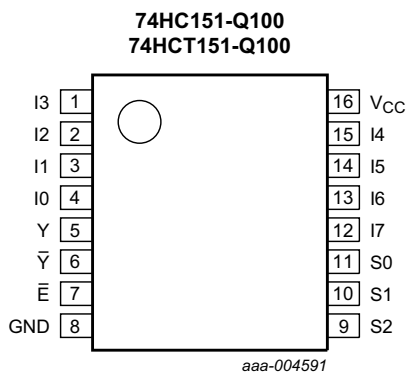

Fig 4. Pin configuration SO16 and TSSOP16

### 5.2 Pin description

Table 2. Pin description

Symbol	Pin	Description
I0 to I7	4, 3, 2, 1, 15, 14, 13, 12	data inputs
Y	5	multiplexer output
$\bar{Y}$	6	complementary multiplexer output
$\bar{E}$	7	enable input (active LOW)
GND	8	ground (0 V)
S0, S1, S2	11, 10, 9	common data select inputs
V <sub>CC</sub>	16	supply voltage

## 6. Functional description

Table 3. Function table<sup>[1]</sup>

Input												Output	
$\bar{E}$	S2	S1	S0	I0	I1	I2	I3	I4	I5	I6	I7	$\bar{Y}$	Y
H	X	X	X	X	X	X	X	X	X	X	X	H	L
L	L	L	L	L	X	X	X	X	X	X	X	H	L
L	L	L	L	H	X	X	X	X	X	X	X	L	H
L	L	L	H	X	L	X	X	X	X	X	X	H	L
L	L	L	H	X	H	X	X	X	X	X	X	L	H
L	L	H	L	X	X	L	X	X	X	X	X	H	L
L	L	H	L	X	X	H	X	X	X	X	X	L	H
L	L	H	H	X	X	X	L	X	X	X	X	H	L
L	L	H	H	X	X	X	H	X	X	X	X	L	H
L	H	L	L	X	X	X	X	L	X	X	X	H	L
L	H	L	L	X	X	X	X	H	X	X	X	L	H
L	H	L	H	X	X	X	X	X	L	X	X	H	L
L	H	L	H	X	X	X	X	X	H	X	X	L	H
L	H	H	L	X	X	X	X	X	X	L	X	H	L
L	H	H	L	X	X	X	X	X	X	H	X	L	H
L	H	H	H	X	X	X	X	X	X	X	L	H	L
L	H	H	H	X	X	X	X	X	X	X	H	L	H

[1] H = HIGH voltage level; L = LOW voltage level; X = don't care.

## 7. Limiting values

Table 4. Limiting values

In accordance with the Absolute Maximum Rating System (IEC 60134). Voltages are referenced to GND (ground = 0 V).

Symbol	Parameter	Conditions	Min	Max	Unit
$V_{CC}$	supply voltage		-0.5	+7	V
$I_{IK}$	input clamping current	$V_I < -0.5\text{ V}$ or $V_I > V_{CC} + 0.5\text{ V}$	-	$\pm 20$	mA
$I_{OK}$	output clamping current	$V_O < -0.5\text{ V}$ or $V_O > V_{CC} + 0.5\text{ V}$	-	$\pm 20$	mA
$I_O$	output current	$V_O = -0.5\text{ V}$ to $(V_{CC} + 0.5\text{ V})$	-	$\pm 25$	mA
$I_{CC}$	supply current		-	+50	mA
$I_{GND}$	ground current		-	-50	mA
$T_{stg}$	storage temperature		-65	+150	°C

**Table 4.** Limiting values ...continued

In accordance with the Absolute Maximum Rating System (IEC 60134). Voltages are referenced to GND (ground = 0 V).

Symbol	Parameter	Conditions	Min	Max	Unit
P <sub>tot</sub>	total power dissipation	T <sub>amb</sub> = -40 °C to +125 °C			
	SO16 package		[1] -	500	mW
	TSSOP16 package		[2] -	500	mW

[1] For SO16 package: P<sub>tot</sub> derates linearly with 8 mW/K above 70 °C.

[2] For TSSOP16 package: P<sub>tot</sub> derates linearly with 5.5 mW/K above 60 °C.

## 8. Recommended operating conditions

**Table 5.** Recommended operating conditions

Voltages are referenced to GND (ground = 0 V)

Symbol	Parameter	Conditions	74HC151-Q100			74HCT151-Q100			Unit
			Min	Typ	Max	Min	Typ	Max	
V <sub>CC</sub>	supply voltage		2.0	5.0	6.0	4.5	5.0	5.5	V
V <sub>I</sub>	input voltage		0	-	V <sub>CC</sub>	0	-	V <sub>CC</sub>	V
V <sub>O</sub>	output voltage		0	-	V <sub>CC</sub>	0	-	V <sub>CC</sub>	V
T <sub>amb</sub>	ambient temperature		-40	+25	+125	-40	+25	+125	°C
Δt/ΔV	input transition rise and fall rate	V <sub>CC</sub> = 2.0 V	-	-	625	-	-	-	ns/V
		V <sub>CC</sub> = 4.5 V	-	1.67	139	-	1.67	139	ns/V
		V <sub>CC</sub> = 6.0 V	-	-	83	-	-	-	ns/V

## 9. Static characteristics

**Table 6. Static characteristics**

At recommended operating conditions; voltages are referenced to GND (ground = 0 V).

Symbol	Parameter	Conditions	T <sub>amb</sub> = 25 °C			T <sub>amb</sub> = -40 °C to +85 °C		T <sub>amb</sub> = -40 °C to +125 °C		Unit
			Min	Typ	Max	Min	Max	Min	Max	
<b>74HC151-Q100</b>										
V <sub>IH</sub>	HIGH-level input voltage	V <sub>CC</sub> = 2.0 V	1.5	1.2	-	1.5	-	1.5	-	V
		V <sub>CC</sub> = 4.5 V	3.15	2.4	-	3.15	-	3.15	-	V
		V <sub>CC</sub> = 6.0 V	4.2	3.2	-	4.2	-	4.2	-	V
V <sub>IL</sub>	LOW-level input voltage	V <sub>CC</sub> = 2.0 V	-	0.8	0.5	-	0.5	-	0.5	V
		V <sub>CC</sub> = 4.5 V	-	2.1	1.35	-	1.35	-	1.35	V
		V <sub>CC</sub> = 6.0 V	-	2.8	1.8	-	1.8	-	1.8	V
V <sub>OH</sub>	HIGH-level output voltage	V <sub>I</sub> = V <sub>IH</sub> or V <sub>IL</sub>								
		I <sub>O</sub> = -20 μA; V <sub>CC</sub> = 2.0 V	1.9	2.0	-	1.9	-	1.9	-	V
		I <sub>O</sub> = -20 μA; V <sub>CC</sub> = 4.5 V	4.4	4.5	-	4.4	-	4.4	-	V
		I <sub>O</sub> = -20 μA; V <sub>CC</sub> = 6.0 V	5.9	6.0	-	5.9	-	5.9	-	V
		I <sub>O</sub> = -4.0 mA; V <sub>CC</sub> = 4.5 V	3.98	4.32	-	3.84	-	3.7	-	V
		I <sub>O</sub> = -5.2 mA; V <sub>CC</sub> = 6.0 V	5.48	5.81	-	5.34	-	5.2	-	V
V <sub>OL</sub>	LOW-level output voltage	V <sub>I</sub> = V <sub>IH</sub> or V <sub>IL</sub>								
		I <sub>O</sub> = 20 μA; V <sub>CC</sub> = 2.0 V	-	0	0.1	-	0.1	-	0.1	V
		I <sub>O</sub> = 20 μA; V <sub>CC</sub> = 4.5 V	-	0	0.1	-	0.1	-	0.1	V
		I <sub>O</sub> = 20 μA; V <sub>CC</sub> = 6.0 V	-	0	0.1	-	0.1	-	0.1	V
		I <sub>O</sub> = 4.0 mA; V <sub>CC</sub> = 4.5 V	-	0.15	0.26	-	0.33	-	0.4	V
		I <sub>O</sub> = 5.2 mA; V <sub>CC</sub> = 6.0 V	-	0.16	0.26	-	0.33	-	0.4	V
I <sub>I</sub>	input leakage current	V <sub>I</sub> = V <sub>CC</sub> or GND; V <sub>CC</sub> = 6.0 V	-	-	±0.1	-	±1.0	-	±1.0	μA
I <sub>CC</sub>	supply current	V <sub>I</sub> = V <sub>CC</sub> or GND; I <sub>O</sub> = 0 A; V <sub>CC</sub> = 6.0 V	-	-	8.0	-	80	-	160	μA
C <sub>I</sub>	input capacitance		-	3.5	-					pF

**Table 6. Static characteristics ...continued**

At recommended operating conditions; voltages are referenced to GND (ground = 0 V).

Symbol	Parameter	Conditions	T <sub>amb</sub> = 25 °C			T <sub>amb</sub> = -40 °C to +85 °C		T <sub>amb</sub> = -40 °C to +125 °C		Unit
			Min	Typ	Max	Min	Max	Min	Max	
<b>74HCT151-Q100</b>										
V <sub>IH</sub>	HIGH-level input voltage	V <sub>CC</sub> = 4.5 V to 5.5 V	2.0	1.6	-	2.0	-	2.0	-	V
V <sub>IL</sub>	LOW-level input voltage	V <sub>CC</sub> = 4.5 V to 5.5 V	-	1.2	0.8	-	0.8	-	0.8	V
V <sub>OH</sub>	HIGH-level output voltage	V <sub>I</sub> = V <sub>IH</sub> or V <sub>IL</sub> ; V <sub>CC</sub> = 4.5 V								
		I <sub>O</sub> = -20 μA	4.4	4.5	-	4.4	-	4.4	-	V
		I <sub>O</sub> = -4 mA	3.98	4.32	-	3.84	-	3.7	-	V
V <sub>OL</sub>	LOW-level output voltage	V <sub>I</sub> = V <sub>IH</sub> or V <sub>IL</sub> ; V <sub>CC</sub> = 4.5 V								
		I <sub>O</sub> = 20 μA	-	0	0.1	-	0.1	-	0.1	V
		I <sub>O</sub> = 4.0 mA	-	0.15	0.26	-	0.33	-	0.4	V
I <sub>I</sub>	input leakage current	V <sub>I</sub> = V <sub>CC</sub> or GND; V <sub>CC</sub> = 5.5 V	-	-	±0.1	-	±1.0	-	±1.0	μA
I <sub>CC</sub>	supply current	V <sub>I</sub> = V <sub>CC</sub> or GND; I <sub>O</sub> = 0 A; V <sub>CC</sub> = 5.5 V	-	-	8.0	-	80	-	160	μA
ΔI <sub>CC</sub>	additional supply current	V <sub>I</sub> = V <sub>CC</sub> - 2.1 V; other inputs at V <sub>CC</sub> or GND; V <sub>CC</sub> = 4.5 V to 5.5 V; I <sub>O</sub> = 0 A								
		per input pin; I <sub>n</sub> inputs	-	45	162	-	203	-	221	μA
		per input pin; $\bar{E}$ input	-	30	108	-	135	-	147	μA
		per input pin; S <sub>n</sub> input	-	150	540	-	675	-	735	μA
C <sub>I</sub>	input capacitance		-	3.5	-					pF

## 10. Dynamic characteristics

**Table 7. Dynamic characteristics**

Voltages are referenced to GND (ground = 0 V);  $C_L = 50$  pF unless otherwise specified; for test circuit see [Figure 7](#).

Symbol	Parameter	Conditions	$T_{amb} = 25\text{ }^{\circ}\text{C}$			$T_{amb} = -40\text{ }^{\circ}\text{C}$ to $+85\text{ }^{\circ}\text{C}$		$T_{amb} = -40\text{ }^{\circ}\text{C}$ to $+125\text{ }^{\circ}\text{C}$		Unit
			Min	Typ	Max	Min	Max	Min	Max	
<b>74HC151-Q100</b>										
$t_{pd}$	propagation delay	In to Y; see <a href="#">Figure 5</a>	<a href="#">[1]</a>							
		$V_{CC} = 2.0\text{ V}$	-	52	170	-	215	-	255	ns
		$V_{CC} = 4.5\text{ V}$	-	19	34	-	43	-	51	ns
		$V_{CC} = 5\text{ V}; C_L = 15\text{ pF}$	-	17	-	-	-	-	-	ns
		$V_{CC} = 6.0\text{ V}$	-	15	29	-	37	-	43	ns
		In to $\bar{Y}$ ; see <a href="#">Figure 5</a>	<a href="#">[1]</a>							
		$V_{CC} = 2.0\text{ V}$	-	58	185	-	230	-	280	ns
		$V_{CC} = 4.5\text{ V}$	-	21	37	-	46	-	56	ns
		$V_{CC} = 5\text{ V}; C_L = 15\text{ pF}$	-	17	-	-	-	-	-	ns
		$V_{CC} = 6.0\text{ V}$	-	17	31	-	39	-	48	ns
		Sn to Y; see <a href="#">Figure 6</a>	<a href="#">[1]</a>							
		$V_{CC} = 2.0\text{ V}$	-	61	185	-	230	-	280	ns
		$V_{CC} = 4.5\text{ V}$	-	22	37	-	46	-	56	ns
		$V_{CC} = 5\text{ V}; C_L = 15\text{ pF}$	-	19	-	-	-	-	-	ns
		$V_{CC} = 6.0\text{ V}$	-	18	31	-	39	-	48	ns
		Sn to $\bar{Y}$ ; see <a href="#">Figure 6</a>	<a href="#">[1]</a>							
		$V_{CC} = 2.0\text{ V}$	-	61	205	-	255	-	310	ns
		$V_{CC} = 4.5\text{ V}$	-	22	41	-	51	-	62	ns
		$V_{CC} = 5\text{ V}; C_L = 15\text{ pF}$	-	19	-	-	-	-	-	ns
		$V_{CC} = 6.0\text{ V}$	-	18	35	-	43	-	53	ns
		$\bar{E}$ to Y; see <a href="#">Figure 6</a>	<a href="#">[1]</a>							
		$V_{CC} = 2.0\text{ V}$	-	41	125	-	155	-	190	ns
		$V_{CC} = 4.5\text{ V}$	-	15	25	-	31	-	38	ns
		$V_{CC} = 5\text{ V}; C_L = 15\text{ pF}$	-	12	-	-	-	-	-	ns
$V_{CC} = 6.0\text{ V}$	-	12	21	-	26	-	32	ns		
$\bar{E}$ to $\bar{Y}$ ; see <a href="#">Figure 6</a>	<a href="#">[1]</a>									
$V_{CC} = 2.0\text{ V}$	-	47	145	-	180	-	220	ns		
$V_{CC} = 4.5\text{ V}$	-	17	29	-	36	-	44	ns		
$V_{CC} = 5\text{ V}; C_L = 15\text{ pF}$	-	14	-	-	-	-	-	ns		
$V_{CC} = 6.0\text{ V}$	-	14	25	-	31	-	38	ns		
$t_t$	transition time	Y, $\bar{Y}$ ; see <a href="#">Figure 5</a>	<a href="#">[2]</a>							
		$V_{CC} = 2.0\text{ V}$	-	19	75	-	95	-	110	ns
		$V_{CC} = 4.5\text{ V}$	-	7	15	-	19	-	22	ns
		$V_{CC} = 6.0\text{ V}$	-	6	13	-	16	-	19	ns

**Table 7. Dynamic characteristics ...continued**

Voltages are referenced to GND (ground = 0 V);  $C_L = 50$  pF unless otherwise specified; for test circuit see [Figure 7](#).

Symbol	Parameter	Conditions	$T_{amb} = 25\text{ }^{\circ}\text{C}$			$T_{amb} = -40\text{ }^{\circ}\text{C}$ to $+85\text{ }^{\circ}\text{C}$		$T_{amb} = -40\text{ }^{\circ}\text{C}$ to $+125\text{ }^{\circ}\text{C}$		Unit	
			Min	Typ	Max	Min	Max	Min	Max		
$C_{PD}$	power dissipation capacitance	$C_L = 50$ pF; $f = 1$ MHz; $V_I = \text{GND to } V_{CC}$	[3]	-	40	-	-	-	-	pF	
<b>74HCT151-Q100</b>											
$t_{pd}$	propagation delay	In to Y; see <a href="#">Figure 5</a>	[1]	-	22	38	-	48	-	57	ns
		$V_{CC} = 4.5$ V	-	19	-	-	-	-	-	ns	
	$V_{CC} = 5$ V; $C_L = 15$ pF	-	19	-	-	-	-	-	ns		
	In to $\bar{Y}$ ; see <a href="#">Figure 5</a>	[1]	-	22	38	-	48	-	57	ns	
	$V_{CC} = 4.5$ V	-	19	-	-	-	-	-	ns		
	$V_{CC} = 5$ V; $C_L = 15$ pF	-	19	-	-	-	-	-	ns		
	Sn to Y; see <a href="#">Figure 6</a>	[1]	-	23	41	-	51	-	62	ns	
	$V_{CC} = 4.5$ V	-	20	-	-	-	-	-	ns		
	$V_{CC} = 5$ V; $C_L = 15$ pF	-	20	-	-	-	-	-	ns		
	Sn to $\bar{Y}$ ; see <a href="#">Figure 6</a>	[1]	-	25	43	-	54	-	65	ns	
	$V_{CC} = 4.5$ V	-	20	-	-	-	-	-	ns		
	$V_{CC} = 5$ V; $C_L = 15$ pF	-	20	-	-	-	-	-	ns		
	$\bar{E}$ to Y; see <a href="#">Figure 6</a>	[1]	-	16	29	-	36	-	44	ns	
	$V_{CC} = 4.5$ V	-	13	-	-	-	-	-	ns		
$V_{CC} = 5$ V; $C_L = 15$ pF	-	13	-	-	-	-	-	ns			
$\bar{E}$ to $\bar{Y}$ ; see <a href="#">Figure 6</a>	[1]	-	21	36	-	45	-	54	ns		
$V_{CC} = 4.5$ V	-	18	-	-	-	-	-	ns			
$V_{CC} = 5$ V; $C_L = 15$ pF	-	18	-	-	-	-	-	ns			
$t_t$	transition time	Y, $\bar{Y}$ ; see <a href="#">Figure 5</a>	[2]	-	7	15	-	19	-	22	ns
		$V_{CC} = 4.5$ V	-	7	15	-	19	-	22	ns	
$C_{PD}$	power dissipation capacitance	$C_L = 50$ pF; $f = 1$ MHz; $V_I = \text{GND to } V_{CC}$	[3]	-	40	-	-	-	-	pF	

[1]  $t_{pd}$  is the same as  $t_{PLH}$  and  $t_{PHL}$ .

[2]  $t_t$  is the same as  $t_{THL}$  and  $t_{TLH}$ .

[3]  $C_{PD}$  is used to determine the dynamic power dissipation ( $P_D$  in  $\mu\text{W}$ ).

$$P_D = C_{PD} \times V_{CC}^2 \times f_i \times N + \sum(C_L \times V_{CC}^2 \times f_o) \text{ where:}$$

$f_i$  = input frequency in MHz;

$f_o$  = output frequency in MHz;

$C_L$  = output load capacitance in pF;

$V_{CC}$  = supply voltage in V;

$N$  = number of inputs switching;

$\sum(C_L \times V_{CC}^2 \times f_o)$  = sum of outputs.

11. Waveforms

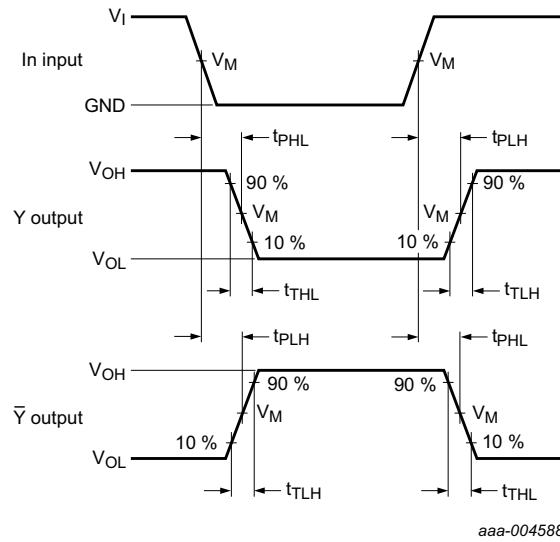

Measurement points are given in [Table 8](#).  
 $V_{OL}$  and  $V_{OH}$  are typical voltage output levels that occur with the output load.

**Fig 5. Propagation delay input (In) to output (Y,  $\bar{Y}$ ) and the output (Y,  $\bar{Y}$ ) transition time**

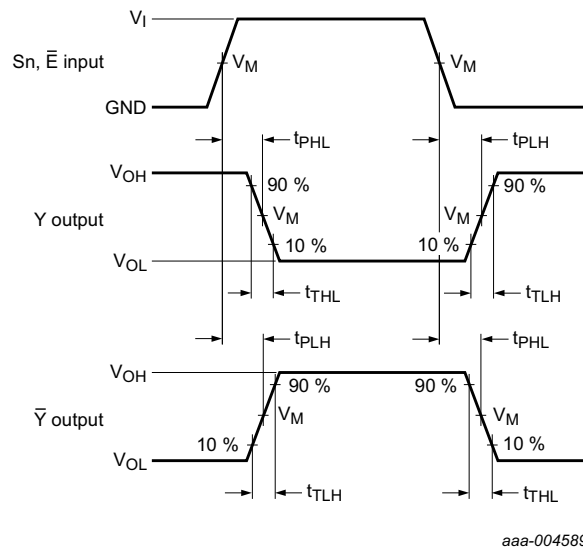

Measurement points are given in [Table 8](#).  
 $V_{OL}$  and  $V_{OH}$  are typical voltage output levels that occur with the output load.

**Fig 6. Propagation delay input (Sn,  $\bar{E}$ ) to output (Y,  $\bar{Y}$ ) and output (Y,  $\bar{Y}$ ) transitions time**

**Table 8. Measurement points**

Type	Input	Output
	$V_M$	$V_M$
74HC151-Q100	$0.5V_{CC}$	$0.5V_{CC}$
74HCT151-Q100	1.3 V	1.3 V

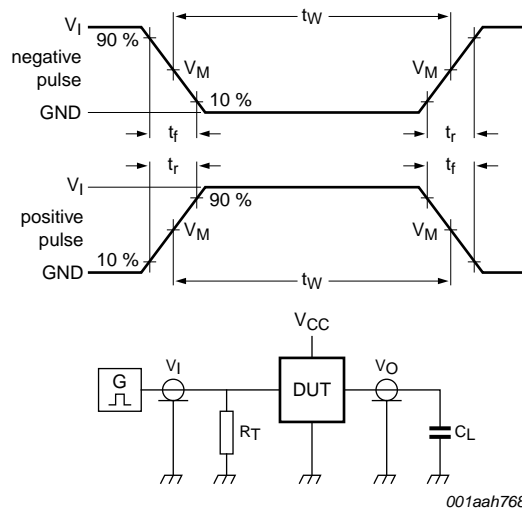

Test data is given in [Table 9](#).

Definitions test circuit:

$R_T$  = Termination resistance should be equal to output impedance  $Z_o$  of the pulse generator.

$C_L$  = Load capacitance including jig and probe capacitance.

$R_L$  = Load resistance.

S1 = Test selection switch.

**Fig 7. Test circuit for measuring switching times**

**Table 9. Test data**

Type	Input		Load	Test
	$V_I$	$t_r, t_f$	$C_L$	
74HC151-Q100	$V_{CC}$	6.0 ns	15 pF, 50 pF	$t_{PLH}, t_{PHL}$
74HCT151-Q100	3.0 V	6.0 ns	15 pF, 50 pF	$t_{PLH}, t_{PHL}$

12. Package outline

SO16: plastic small outline package; 16 leads; body width 3.9 mm

SOT109-1

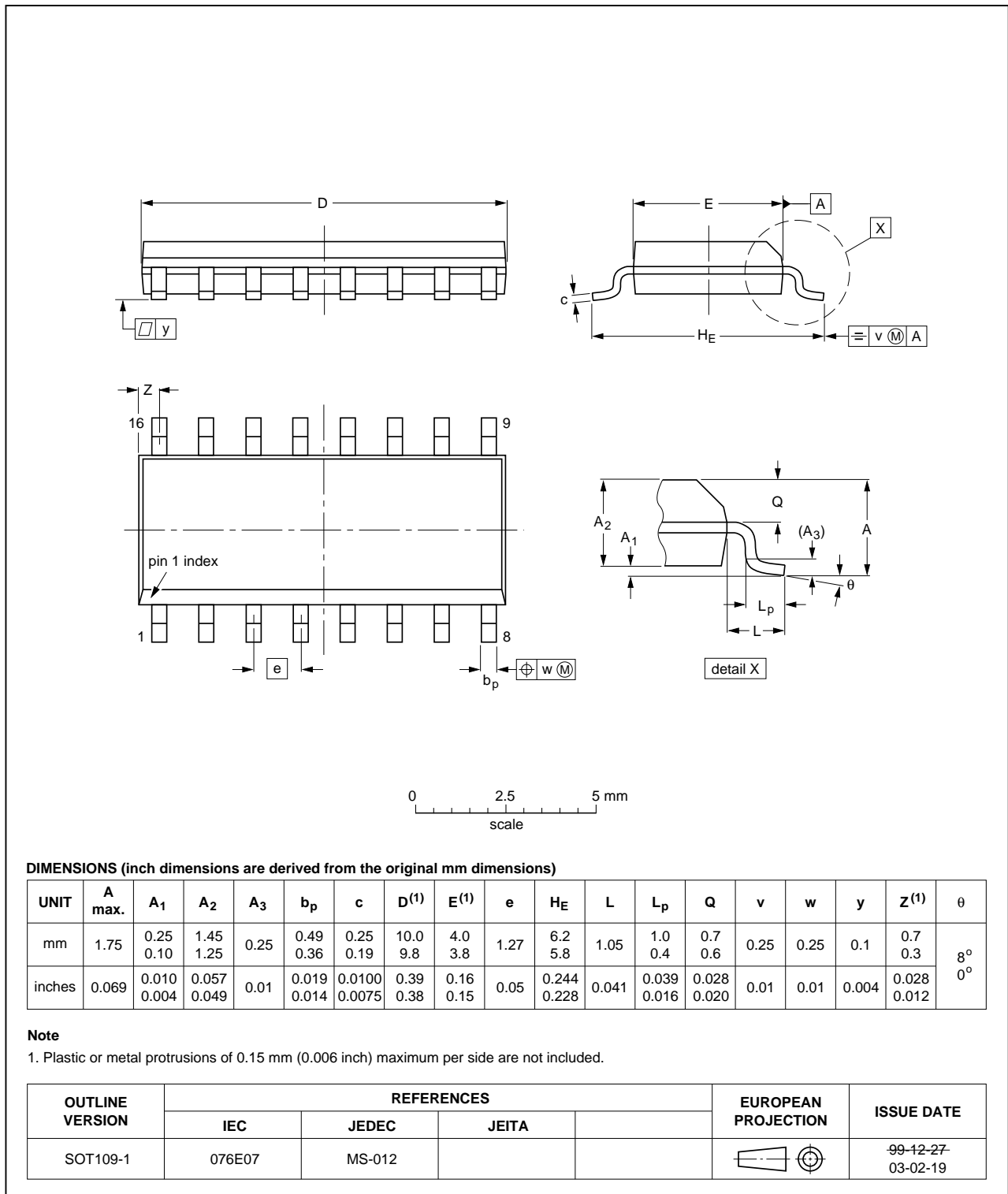

Fig 8. Package outline SOT109-1 (SO16)

TSSOP16: plastic thin shrink small outline package; 16 leads; body width 4.4 mm

SOT403-1

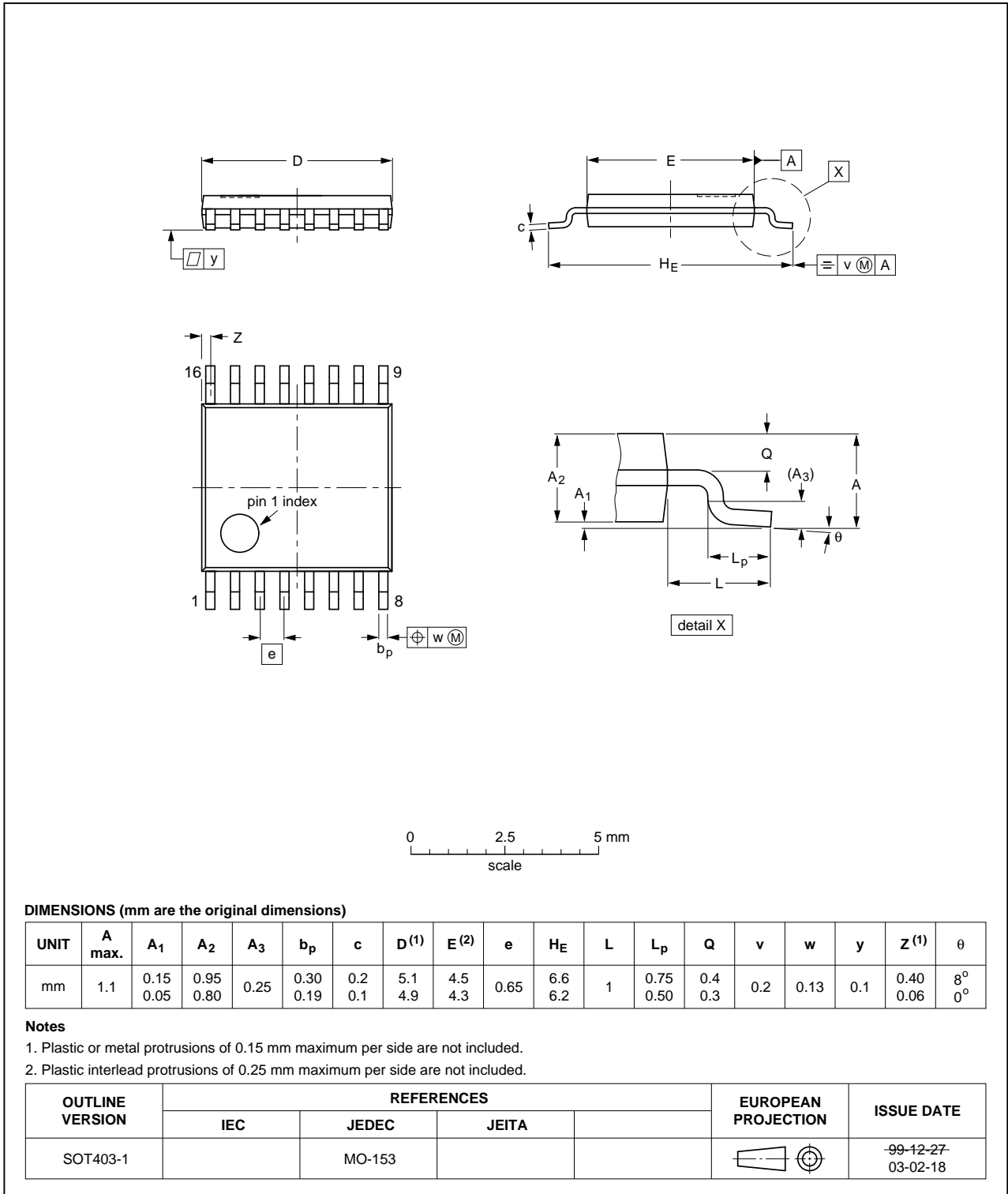

Fig 9. Package outline SOT403-1 (TSSOP16)

## 13. Abbreviations

Table 10. Abbreviations

Acronym	Description
CMOS	Complementary Metal Oxide Semiconductor
DUT	Device Under Test
ESD	ElectroStatic Discharge
HBM	Human Body Model
MM	Machine Model
TTL	Transistor-Transistor Logic
MIL	Military

## 14. Revision history

Table 11. Revision history

Document ID	Release date	Data sheet status	Change notice	Supersedes
74HC_HCT151_Q100 v.2	20130211	Product data sheet	-	74HC_HCT151_Q100 v.1
Modifications:	• New descriptive title (errata).			
74HC_HCT151_Q100 v.1	20120807	Product data sheet	-	-

## 15. Legal information

### 15.1 Data sheet status

Document status <sup>[1][2]</sup>	Product status <sup>[3]</sup>	Definition
Objective [short] data sheet	Development	This document contains data from the objective specification for product development.
Preliminary [short] data sheet	Qualification	This document contains data from the preliminary specification.
Product [short] data sheet	Production	This document contains the product specification.

[1] Please consult the most recently issued document before initiating or completing a design.

[2] The term 'short data sheet' is explained in section "Definitions".

[3] The product status of device(s) described in this document may have changed since this document was published and may differ in case of multiple devices. The latest product status information is available on the Internet at URL <http://www.nxp.com>.

### 15.2 Definitions

**Draft** — The document is a draft version only. The content is still under internal review and subject to formal approval, which may result in modifications or additions. NXP Semiconductors does not give any representations or warranties as to the accuracy or completeness of information included herein and shall have no liability for the consequences of use of such information.

**Short data sheet** — A short data sheet is an extract from a full data sheet with the same product type number(s) and title. A short data sheet is intended for quick reference only and should not be relied upon to contain detailed and full information. For detailed and full information see the relevant full data sheet, which is available on request via the local NXP Semiconductors sales office. In case of any inconsistency or conflict with the short data sheet, the full data sheet shall prevail.

**Product specification** — The information and data provided in a Product data sheet shall define the specification of the product as agreed between NXP Semiconductors and its customer, unless NXP Semiconductors and customer have explicitly agreed otherwise in writing. In no event however, shall an agreement be valid in which the NXP Semiconductors product is deemed to offer functions and qualities beyond those described in the Product data sheet.

### 15.3 Disclaimers

**Limited warranty and liability** — Information in this document is believed to be accurate and reliable. However, NXP Semiconductors does not give any representations or warranties, expressed or implied, as to the accuracy or completeness of such information and shall have no liability for the consequences of use of such information. NXP Semiconductors takes no responsibility for the content in this document if provided by an information source outside of NXP Semiconductors.

In no event shall NXP Semiconductors be liable for any indirect, incidental, punitive, special or consequential damages (including - without limitation - lost profits, lost savings, business interruption, costs related to the removal or replacement of any products or rework charges) whether or not such damages are based on tort (including negligence), warranty, breach of contract or any other legal theory.

Notwithstanding any damages that customer might incur for any reason whatsoever, NXP Semiconductors' aggregate and cumulative liability towards customer for the products described herein shall be limited in accordance with the *Terms and conditions of commercial sale* of NXP Semiconductors.

**Right to make changes** — NXP Semiconductors reserves the right to make changes to information published in this document, including without limitation specifications and product descriptions, at any time and without notice. This document supersedes and replaces all information supplied prior to the publication hereof.

**Suitability for use in automotive applications** — This NXP Semiconductors product has been qualified for use in automotive applications. Unless otherwise agreed in writing, the product is not designed, authorized or warranted to be suitable for use in life support, life-critical or safety-critical systems or equipment, nor in applications where failure or malfunction of an NXP Semiconductors product can reasonably be expected to result in personal injury, death or severe property or environmental damage. NXP Semiconductors and its suppliers accept no liability for inclusion and/or use of NXP Semiconductors products in such equipment or applications and therefore such inclusion and/or use is at the customer's own risk.

**Applications** — Applications that are described herein for any of these products are for illustrative purposes only. NXP Semiconductors makes no representation or warranty that such applications will be suitable for the specified use without further testing or modification.

Customers are responsible for the design and operation of their applications and products using NXP Semiconductors products, and NXP Semiconductors accepts no liability for any assistance with applications or customer product design. It is customer's sole responsibility to determine whether the NXP Semiconductors product is suitable and fit for the customer's applications and products planned, as well as for the planned application and use of customer's third party customer(s). Customers should provide appropriate design and operating safeguards to minimize the risks associated with their applications and products.

NXP Semiconductors does not accept any liability related to any default, damage, costs or problem which is based on any weakness or default in the customer's applications or products, or the application or use by customer's third party customer(s). Customer is responsible for doing all necessary testing for the customer's applications and products using NXP Semiconductors products in order to avoid a default of the applications and the products or of the application or use by customer's third party customer(s). NXP does not accept any liability in this respect.

**Limiting values** — Stress above one or more limiting values (as defined in the Absolute Maximum Ratings System of IEC 60134) will cause permanent damage to the device. Limiting values are stress ratings only and (proper) operation of the device at these or any other conditions above those given in the Recommended operating conditions section (if present) or the Characteristics sections of this document is not warranted. Constant or repeated exposure to limiting values will permanently and irreversibly affect the quality and reliability of the device.

**Terms and conditions of commercial sale** — NXP Semiconductors products are sold subject to the general terms and conditions of commercial sale, as published at <http://www.nxp.com/profile/terms>, unless otherwise agreed in a valid written individual agreement. In case an individual agreement is concluded only the terms and conditions of the respective agreement shall apply. NXP Semiconductors hereby expressly objects to applying the customer's general terms and conditions with regard to the purchase of NXP Semiconductors products by customer.

**No offer to sell or license** — Nothing in this document may be interpreted or construed as an offer to sell products that is open for acceptance or the grant, conveyance or implication of any license under any copyrights, patents or other industrial or intellectual property rights.

**Export control** — This document as well as the item(s) described herein may be subject to export control regulations. Export might require a prior authorization from competent authorities.

**Translations** — A non-English (translated) version of a document is for reference only. The English version shall prevail in case of any discrepancy between the translated and English versions.

## 15.4 Trademarks

Notice: All referenced brands, product names, service names and trademarks are the property of their respective owners.

## 16. Contact information

---

For more information, please visit: <http://www.nxp.com>

For sales office addresses, please send an email to: [salesaddresses@nxp.com](mailto:salesaddresses@nxp.com)

## 17. Contents

---

<b>1</b>	<b>General description</b> .....	<b>1</b>
<b>2</b>	<b>Features and benefits</b> .....	<b>1</b>
<b>3</b>	<b>Ordering information</b> .....	<b>1</b>
<b>4</b>	<b>Functional diagram</b> .....	<b>2</b>
<b>5</b>	<b>Pinning information</b> .....	<b>3</b>
5.1	Pinning .....	3
5.2	Pin description .....	3
<b>6</b>	<b>Functional description</b> .....	<b>4</b>
<b>7</b>	<b>Limiting values</b> .....	<b>4</b>
<b>8</b>	<b>Recommended operating conditions</b> .....	<b>5</b>
<b>9</b>	<b>Static characteristics</b> .....	<b>6</b>
<b>10</b>	<b>Dynamic characteristics</b> .....	<b>8</b>
<b>11</b>	<b>Waveforms</b> .....	<b>10</b>
<b>12</b>	<b>Package outline</b> .....	<b>12</b>
<b>13</b>	<b>Abbreviations</b> .....	<b>14</b>
<b>14</b>	<b>Revision history</b> .....	<b>14</b>
<b>15</b>	<b>Legal information</b> .....	<b>15</b>
15.1	Data sheet status .....	15
15.2	Definitions .....	15
15.3	Disclaimers .....	15
15.4	Trademarks .....	16
<b>16</b>	<b>Contact information</b> .....	<b>16</b>
<b>17</b>	<b>Contents</b> .....	<b>17</b>

---

Please be aware that important notices concerning this document and the product(s) described herein, have been included in section 'Legal information'.

© NXP B.V. 2013.

All rights reserved.

For more information, please visit: <http://www.nxp.com>

For sales office addresses, please send an email to: [salesaddresses@nxp.com](mailto:salesaddresses@nxp.com)

Date of release: 11 February 2013

Document identifier: 74HC\_HCT151\_Q100