

DATA SHEET

For a complete data sheet, please also download:

- The IC06 74HC/HCT/HCU/HCMOS Logic Family Specifications
- The IC06 74HC/HCT/HCU/HCMOS Logic Package Information
- The IC06 74HC/HCT/HCU/HCMOS Logic Package Outlines

74HC/HCT4511 BCD to 7-segment latch/decoder/driver

Product specification
File under Integrated Circuits, IC06

December 1990

BCD to 7-segment latch/decoder/driver

74HC/HCT4511

FEATURES

- Latch storage of BCD inputs
- Blanking input
- Lamp test input
- Driving common cathode LED displays
- Guaranteed 10 mA drive capability per output
- Output capability: non-standard
- I_{CC} category: MSI

GENERAL DESCRIPTION

The 74HC/HCT4511 are high-speed Si-gate CMOS devices and are pin compatible with "4511" of the "4000B" series. They are specified in compliance with JEDEC standard no. 7A.

The 74HC/HCT4511 are BCD to 7-segment latch/decoder/drivers with four address inputs (D₁ to D₄), an active LOW latch enable input (\overline{LE}), an active LOW

ripple blanking input (\overline{BI}), an active LOW lamp test input (\overline{LT}), and seven active HIGH segment outputs (Q_a to Q_g).

When \overline{LE} is LOW, the state of the segment outputs (Q_a to Q_g) is determined by the data on D₁ to D₄.

When \overline{LE} goes HIGH, the last data present on D₁ to D₄ are stored in the latches and the segment outputs remain stable.

When \overline{LT} is LOW, all the segment outputs are HIGH independent of all other input conditions. With \overline{LT} HIGH, a LOW on \overline{BI} forces all segment outputs LOW. The inputs \overline{LT} and \overline{BI} do not affect the latch circuit.

APPLICATIONS

- Driving LED displays
- Driving incandescent displays
- Driving fluorescent displays
- Driving LCD displays
- Driving gas discharge displays

QUICK REFERENCE DATA

GND = 0 V; T_{amb} = 25 °C; t_r = t_f = 6 ns

SYMBOL	PARAMETER	CONDITIONS	TYPICAL		UNIT
			HC	HCT	
t _{PHL} / t _{PLH}	propagation delay	C _L = 15 pF; V _{CC} = 5 V			
	D _n to Q _n		24	24	ns
	\overline{LE} to Q _n		23	24	ns
	\overline{BI} to Q _n		19	20	ns
	\overline{LT} to Q _n		12	13	ns
C _I	input capacitance		3.5	3.5	pF
C _{PD}	power dissipation capacitance per latch	notes 1 and 2	64	64	pF

Notes

1. C_{PD} is used to determine the dynamic power dissipation (P_D in μW):

$$P_D = C_{PD} \times V_{CC}^2 \times f_i + \sum (C_L \times V_{CC}^2 \times f_o) \text{ where:}$$

f_i = input frequency in MHz

f_o = output frequency in MHz

∑ (C_L × V_{CC}² × f_o) = sum of outputs

C_L = output load capacitance in pF

V_{CC} = supply voltage in V

2. For HC the condition is V_I = GND to V_{CC}

For HCT the condition is V_I = GND to V_{CC} – 1.5 V

BCD to 7-segment latch/decoder/driver

74HC/HCT4511

ORDERING INFORMATION

See "74HC/HCT/HCU/HCMOS Logic Package Information".

PIN DESCRIPTION

PIN NO.	SYMBOL	NAME AND FUNCTION
3	\overline{LT}	lamp test input (active LOW)
4	\overline{BI}	ripple blanking input (active LOW)
5	\overline{LE}	latch enable input (active LOW)
7, 1, 2, 6	D ₁ to D ₄	BCD address inputs
8	GND	ground (0 V)
13, 12, 11, 10, 9, 15, 14	Q _a to Q _g	segments outputs
16	V _{CC}	positive supply voltage

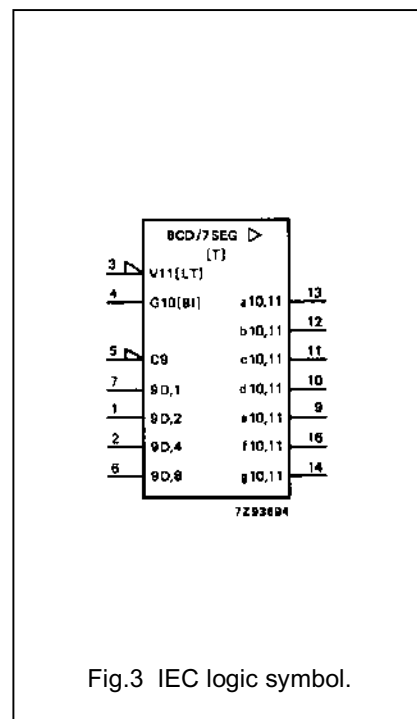
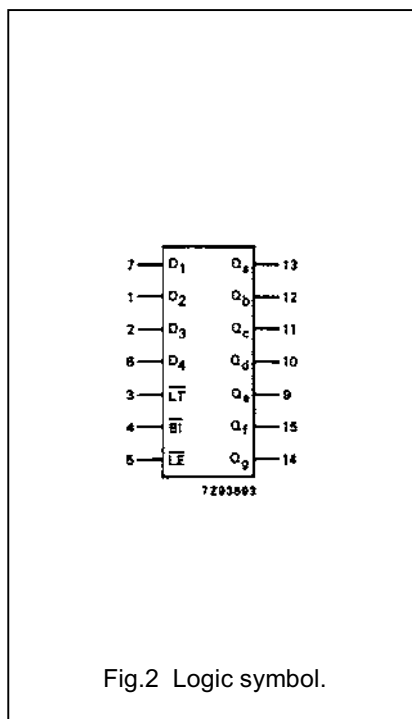
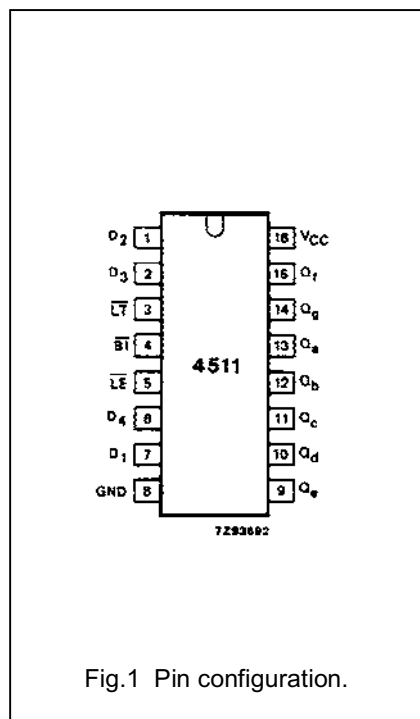

BCD to 7-segment latch/decoder/driver

74HC/HCT4511

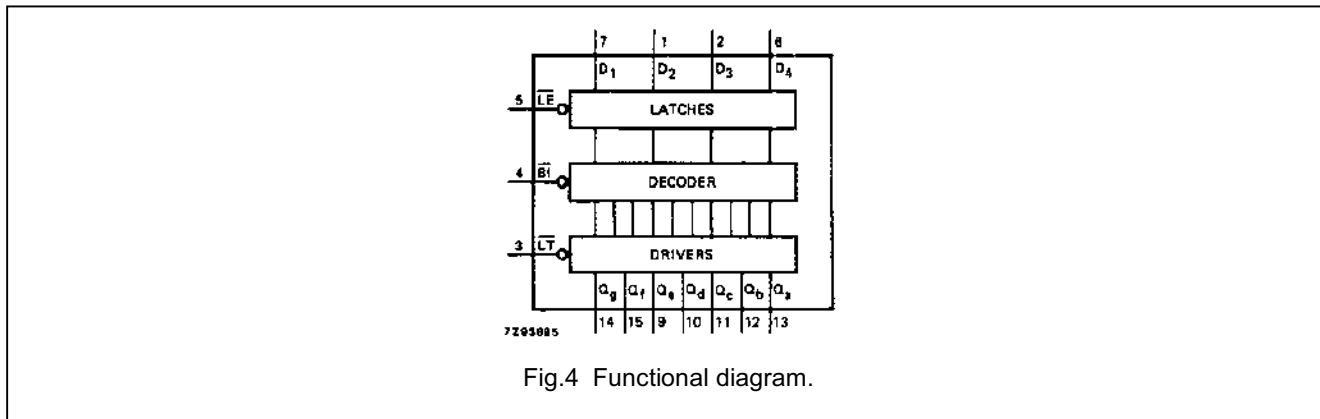

Fig.4 Functional diagram.

FUNCTION TABLE

INPUTS							OUTPUTS							DISPLAY
\overline{LE}	\overline{BI}	\overline{LT}	D ₄	D ₃	D ₂	D ₁	Q _a	Q _b	Q _c	Q _d	Q _e	Q _f	Q _g	
X	X	L	X	X	X	X	H	H	H	H	H	H	H	8
X	L	H	X	X	X	X	L	L	L	L	L	L	L	blank
L	H	H	L	L	L	L	H	H	H	H	H	H	L	0
L	H	H	L	L	L	H	L	H	H	L	L	L	L	1
L	H	H	L	L	H	L	H	H	L	H	H	L	H	2
L	H	H	L	L	H	H	H	H	H	H	L	L	H	3
L	H	H	L	H	L	L	L	H	H	L	L	H	H	4
L	H	H	L	H	L	H	H	L	H	H	L	H	H	5
L	H	H	L	H	H	L	L	L	H	H	H	H	H	6
L	H	H	L	H	H	H	H	H	H	L	L	L	L	7
L	H	H	H	L	L	L	H	H	H	H	H	H	H	8
L	H	H	H	L	L	H	H	H	H	L	L	H	H	9
L	H	H	H	L	H	L	L	L	L	L	L	L	L	blank
L	H	H	H	L	H	H	L	L	L	L	L	L	L	blank
L	H	H	H	H	L	L	L	L	L	L	L	L	L	blank
L	H	H	H	H	L	H	L	L	L	L	L	L	L	blank
L	H	H	H	H	H	L	L	L	L	L	L	L	L	blank
L	H	H	H	H	H	H	L	L	L	L	L	L	L	blank
H	H	H	X	X	X	X	(1)							(1)

Note

- Depends upon the BCD-code applied during the LOW-to-HIGH transition of \overline{LE} .
 H = HIGH voltage level
 L = LOW voltage level
 X = don't care

BCD to 7-segment latch/decoder/driver

74HC/HCT4511

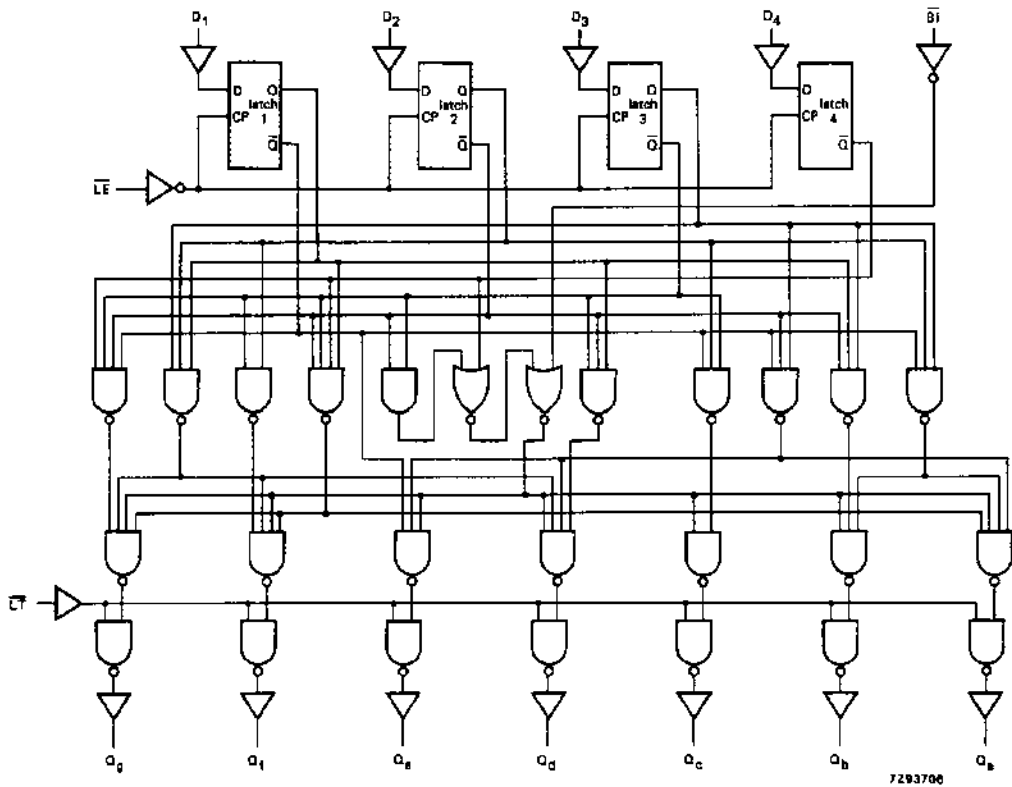

Fig.5 Logic diagram.

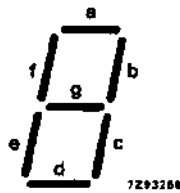

Fig.6 Segment designation.

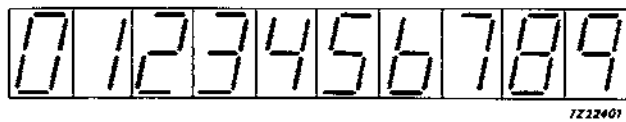

Fig.7 Display.

BCD to 7-segment latch/decoder/driver

74HC/HCT4511

DC CHARACTERISTICS FOR 74HC

For the DC characteristics see "74HC/HCT/HCU/HCMOS Logic Family Specifications".

Output capability: standard, excepting V_{OH} which is given below

I_{CC} category: MSI

Non-standard DC characteristics for 74HC

Voltages are referenced to GND (ground = 0 V)

SYMBOL	PARAMETER	T_{amb} (°C)							UNIT	TEST CONDITIONS		
		74HC								V_{CC} (V)	V_I	$-I_o$ (mA)
		+25			-40 to +85		-40 to +125					
		min.	typ.	max.	min.	max.	min.	max.				
V_{OH}	HIGH level output voltage	3.98			3.84		3.70		V	4.5	V_{IH} or V_{IL}	7.5 10.0
V_{OH}	HIGH level output voltage	5.60			5.45		5.35		V	6.0	V_{IH} or V_{IL}	7.5 10.0 15.0

BCD to 7-segment latch/decoder/driver

74HC/HCT4511

AC CHARACTERISTICS FOR 74HC

GND = 0 V; $t_r = t_f = 6$ ns; $C_L = 50$ pF

SYMBOL	PARAMETER	T_{amb} (°C)						UNIT	TEST CONDITIONS		
		74HC							V_{CC} (V)	WAVEFORMS	
		+25			-40 to +85		-40 to +125				
		min.	typ.	max.	min.	max.	min.				max.
t_{PHL}/t_{PLH}	propagation delay D_n to Q_n		77 28 22	300 60 51		375 75 64		450 90 77	ns	2.0 4.5 6.0	Fig.8
t_{PHL}/t_{PLH}	propagation delay \overline{LE} to Q_n		74 27 22	270 54 46		330 68 58		405 81 69	ns	2.0 4.5 6.0	Fig.9
t_{PHL}/t_{PLH}	propagation delay \overline{BI} to Q_n		61 22 18	220 44 37		275 55 47		330 66 56	ns	2.0 4.5 6.0	Fig.10
t_{PHL}/t_{PLH}	propagation delay \overline{LT} to Q_n		41 15 12	150 30 26		190 38 33		225 45 38	ns	2.0 4.5 6.0	Fig.8
t_{THL}/t_{TLH}	output transition time		19 7 6	75 15 13		95 19 16		110 22 19	ns	2.0 4.5 6.0	Figs 8, 9 and 10
t_W	latch enable pulse width LOW	80 16 14	11 4 3		100 20 17		120 24 20		ns	2.0 4.5 6.0	Fig.9
t_{su}	set-up time D_n to \overline{LE}	60 12 10	14 5 4		75 15 13		90 18 15		ns	2.0 4.5 6.0	Fig.11
t_h	hold time D_n to \overline{LE}	0 0 0	-11 -4 -3		0 0 0		0 0 0		ns	2.0 4.5 6.0	Fig.11

BCD to 7-segment latch/decoder/driver

74HC/HCT4511

DC CHARACTERISTICS FOR 74HCT

For the DC characteristics see "74HC/HCT/HCU/HCMOS Logic Family Specifications".

Output capability: standard, excepting V_{OH} which is given below

I_{CC} category: MSI

Non-standard DC characteristics for 74HCT

Voltages are referenced to GND (ground = 0 V)

SYMBOL	PARAMETER	T_{amb} (°C)							UNIT	TEST CONDITIONS		
		74HCT								V_{CC} (V)	V_I	$-I_o$ (mA)
		+25			-40 to +85		-40 to +125					
		min.	typ.	max.	min.	max.	min.	max.				
V_{OH}	HIGH level output voltage	3.98			3.84		3.70		V	4.5	V_{IH} or V_{IL}	7.5 10.0
		3.60			3.35		3.10					

Note to HCT types

The value of additional quiescent supply current (ΔI_{CC}) for a unit load of 1 is given in the family specifications.

To determine ΔI_{CC} per input, multiply this value by the unit load coefficient shown in the table below.

INPUT	UNIT LOAD COEFFICIENT
\overline{LT} , \overline{LE}	1.50
\overline{BI} , D_n	0.30

BCD to 7-segment latch/decoder/driver

74HC/HCT4511

AC CHARACTERISTICS FOR 74HCT

GND = 0 V; $t_r = t_f = 6$ ns; $C_L = 50$ pF

SYMBOL	PARAMETER	T_{amb} (°C)							UNIT	TEST CONDITIONS	
		74HCT								V_{CC} (V)	WAVEFORMS
		+25			-40 to +85		-40 to +125				
		min.	typ.	max.	min.	max.	min.	max.			
t_{PHL}/t_{PLH}	propagation delay D_n to Q_n		28	60		75		90	ns	4.5	Fig.8
t_{PHL}/t_{PLH}	propagation delay \overline{LE} to Q_n		27	54		68		81	ns	4.5	Fig.9
t_{PHL}/t_{PLH}	propagation delay \overline{BI} to Q_n		23	44		55		66	ns	4.5	Fig.10
t_{PHL}/t_{PLH}	propagation delay \overline{LT} to Q_n		16	30		38		45	ns	4.5	Fig.8
t_{THL}/t_{TLH}	output transition time		7	15		19		22	ns	4.5	Figs 8, 9 and 10
t_W	latch enable pulse width LOW	16	5		20		24		ns	4.5	Fig.9
t_{su}	set-up time D_n to \overline{LE}	12	5		15		18		ns	4.5	Fig.11
t_h	hold time D_n to \overline{LE}	0	-4		0		0		ns	4.5	Fig.11

BCD to 7-segment latch/decoder/driver

74HC/HCT4511

AC WAVEFORMS

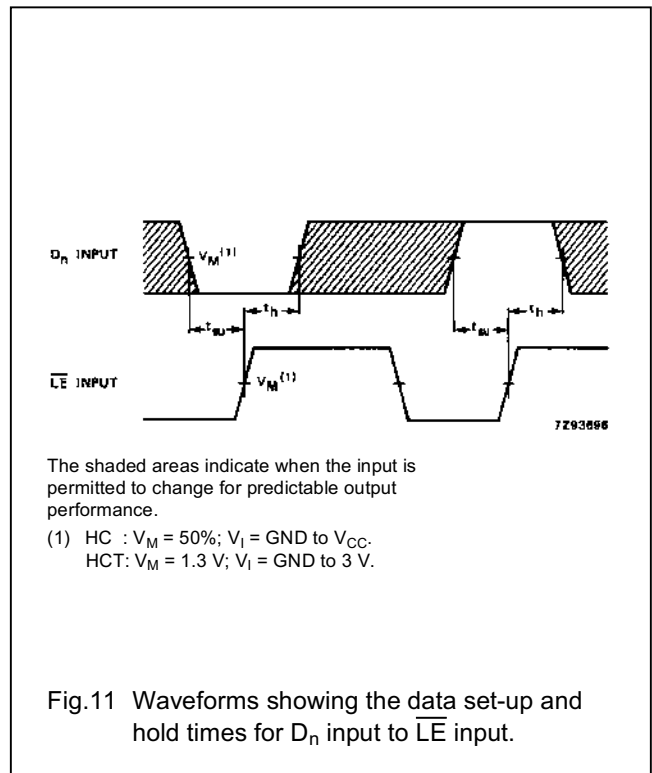
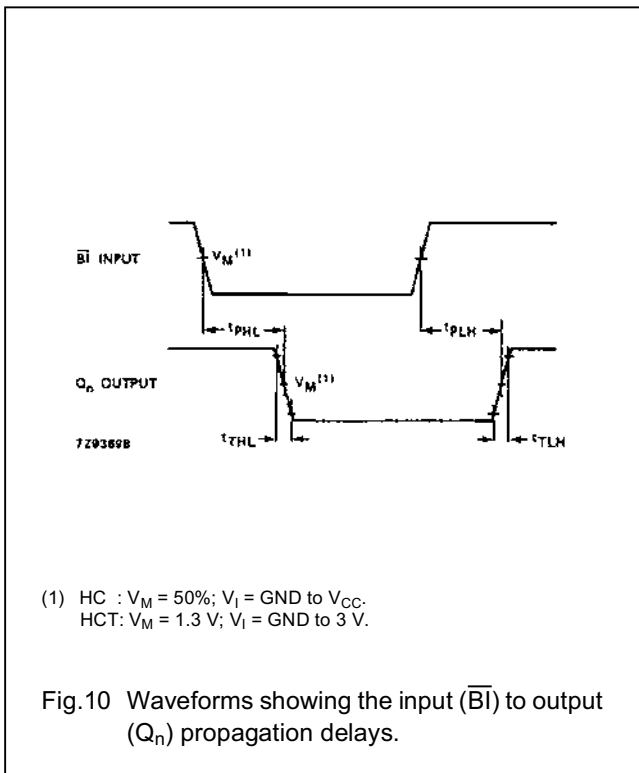
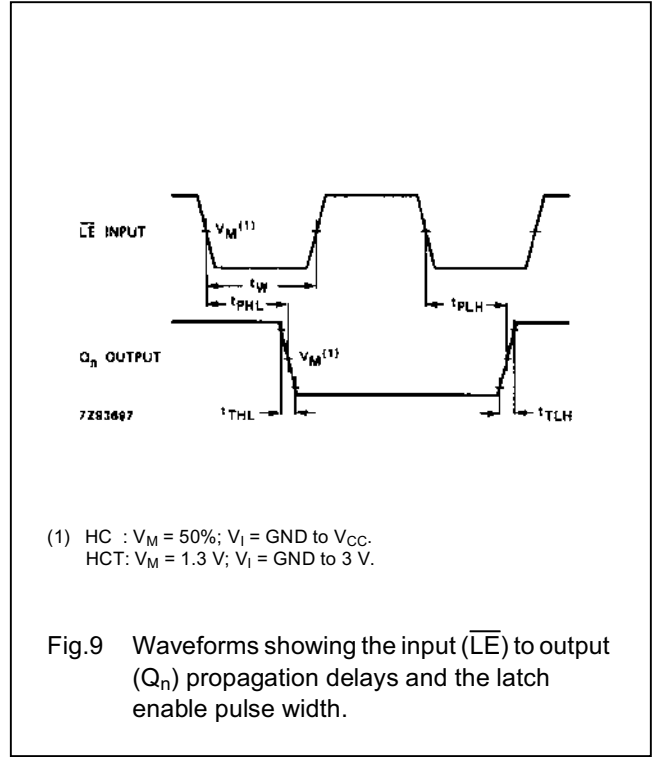
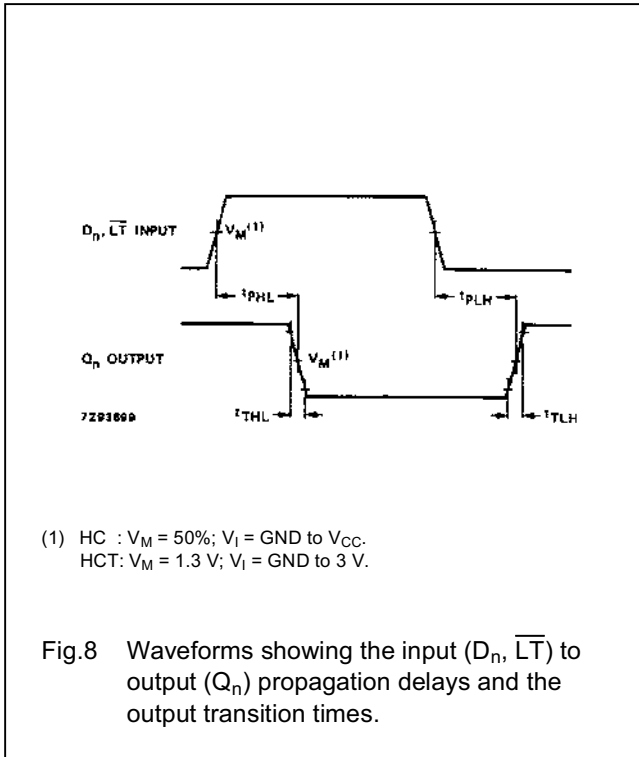

BCD to 7-segment latch/decoder/driver

74HC/HCT4511

APPLICATION DIAGRAMS

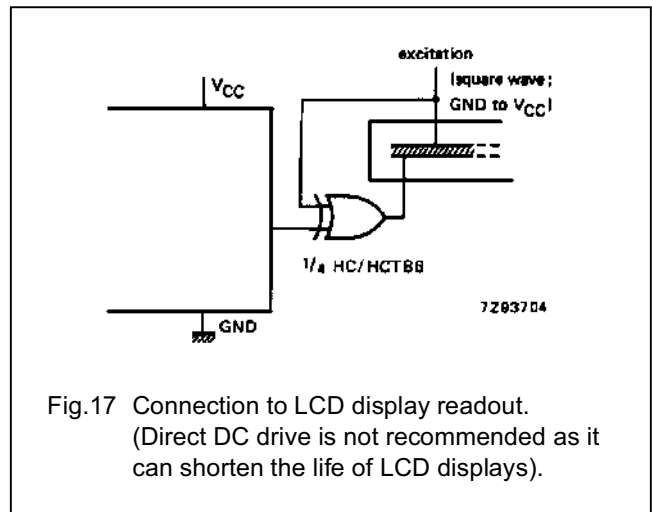
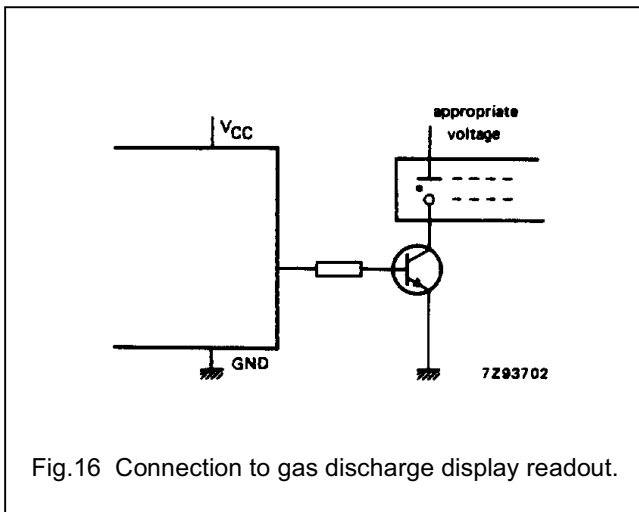
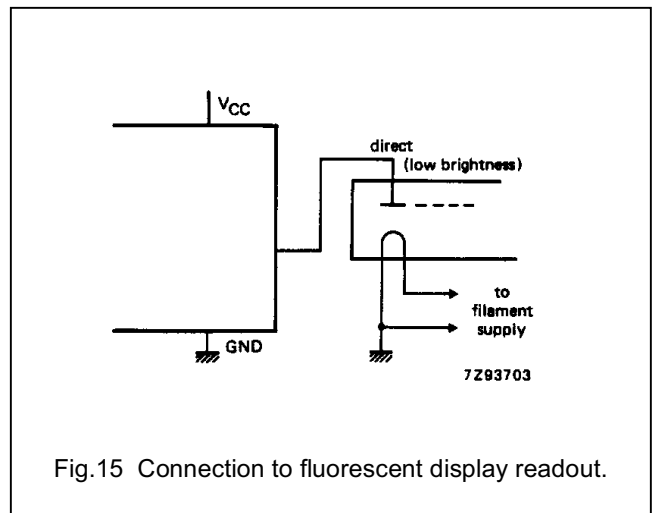
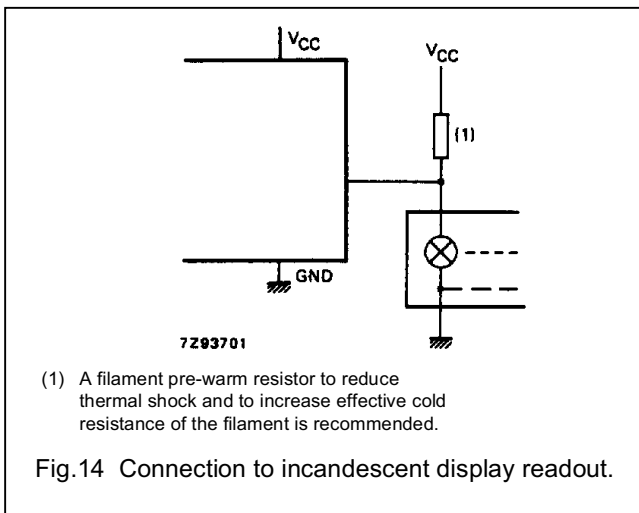
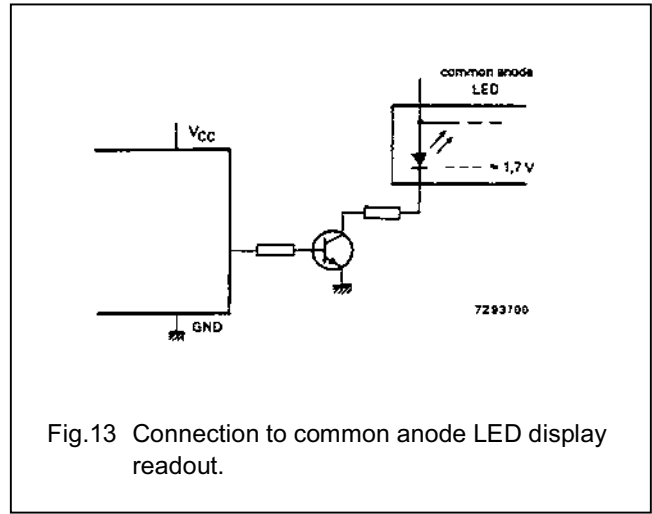
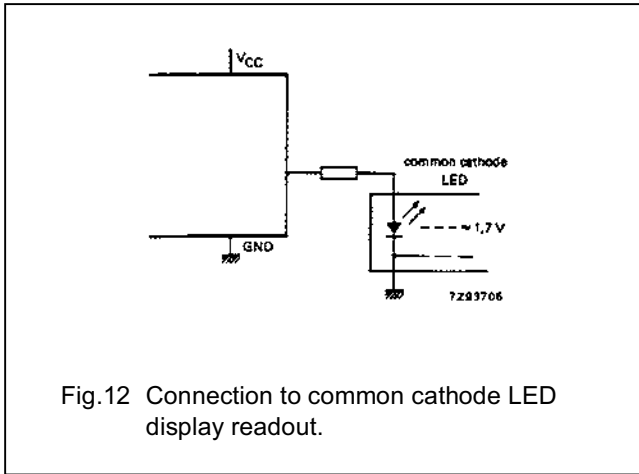

BCD to 7-segment latch/decoder/driver

74HC/HCT4511

PACKAGE OUTLINES

See "74HC/HCT/HCU/HCMOS Logic Package Outlines".