

DATA SHEET

For a complete data sheet, please also download:

- The IC06 74HC/HCT/HCU/HCMOS Logic Family Specifications
- The IC06 74HC/HCT/HCU/HCMOS Logic Package Information
- The IC06 74HC/HCT/HCU/HCMOS Logic Package Outlines

74HC/HCT4520

Dual 4-bit synchronous binary counter

Product specification
File under Integrated Circuits, IC06

December 1990

Dual 4-bit synchronous binary counter

74HC/HCT4520

FEATURES

- Output capability: standard
- I_{CC} category: MSI

GENERAL DESCRIPTION

The 74HC/HCT4520 are high-speed Si-gate CMOS devices and are pin compatible with the "4520" of the "4000B" series. They are specified in compliance with JEDEC standard no. 7A.

The 74HC/HCT4520 are dual 4-bit internally synchronous binary counters with an active HIGH clock input (nCP₀) and an active LOW clock input (nCP₁), buffered outputs

from all four bit positions (nQ₀ to nQ₃) and an active HIGH overriding asynchronous master reset input (nMR).

The counter advances on either the LOW-to-HIGH transition of nCP₀ if nCP₁ is HIGH or the HIGH-to-LOW transition of nCP₁ if nCP₀ is LOW. Either nCP₀ or nCP₁ may be used as the clock input to the counter and the other clock input may be used as a clock enable input. A HIGH on nMR resets the counter (nQ₀ to nQ₃ = LOW) independent of nCP₀ and nCP₁.

APPLICATIONS

- Multistage synchronous counting
- Multistage asynchronous counting
- Frequency dividers

QUICK REFERENCE DATA

GND = 0 V; T_{amb} = 25 °C; t_r = t_f = 6 ns

SYMBOL	PARAMETER	CONDITIONS	TYPICAL		UNIT
			HC	HCT	
t _{PHL} / t _{PLH}	propagation delay nCP ₀ , nCP ₁ to nQ _n	C _L = 15 pF; V _{CC} = 5 V	24	24	ns
t _{PHL}	propagation delay nMR to nQ _n		13	13	ns
f _{max}	maximum clock frequency		68	64	MHz
C _I	input capacitance		3.5	3.5	pF
C _{PD}	power dissipation capacitance per counter	notes 1 and 2	29	24	pF

Notes

1. C_{PD} is used to determine the dynamic power dissipation (P_D in μW):

$$P_D = C_{PD} \times V_{CC}^2 \times f_i + \sum (C_L \times V_{CC}^2 \times f_o) \text{ where:}$$

f_i = input frequency in MHz

f_o = output frequency in MHz

∑ (C_L × V_{CC}² × f_o) = sum of outputs

C_L = output load capacitance in pF

V_{CC} = supply voltage in V

2. For HC the condition is V_I = GND to V_{CC}
For HCT the condition is V_I = GND to V_{CC} - 1.5 V

ORDERING INFORMATION

See "74HC/HCT/HCU/HCMOS Logic Package Information".

Dual 4-bit synchronous binary counter

74HC/HCT4520

PIN DESCRIPTION

PIN NO.	SYMBOL	NAME AND FUNCTION
1, 9	1CP ₀ , 2CP ₀	clock inputs (LOW-to-HIGH, edge-triggered)
2, 10	1CP ₁ , 2CP ₁	clock inputs (HIGH-to-LOW, edge-triggered)
3, 4, 5, 6	1Q ₀ to 1Q ₃	data outputs
7, 15	1MR, 2MR	asynchronous master reset inputs (active HIGH)
8	GND	ground (0 V)
11, 12, 13, 14	2Q ₀ to 2Q ₃	data outputs
16	V _{CC}	positive supply voltage

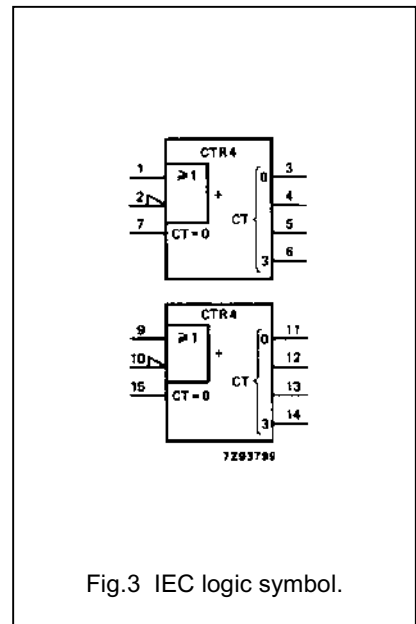
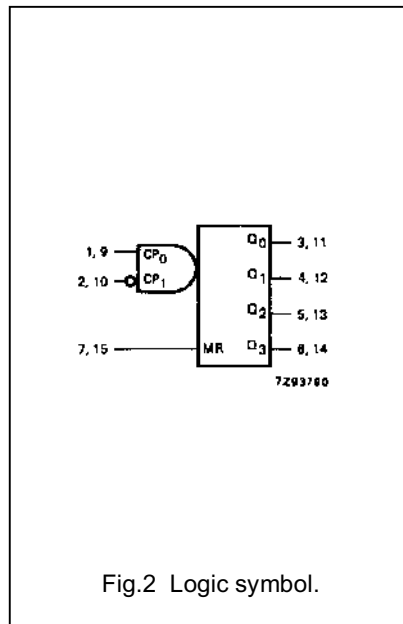
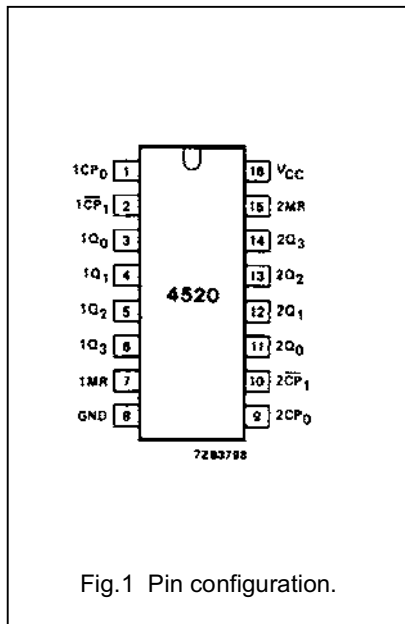

Dual 4-bit synchronous binary counter

74HC/HCT4520

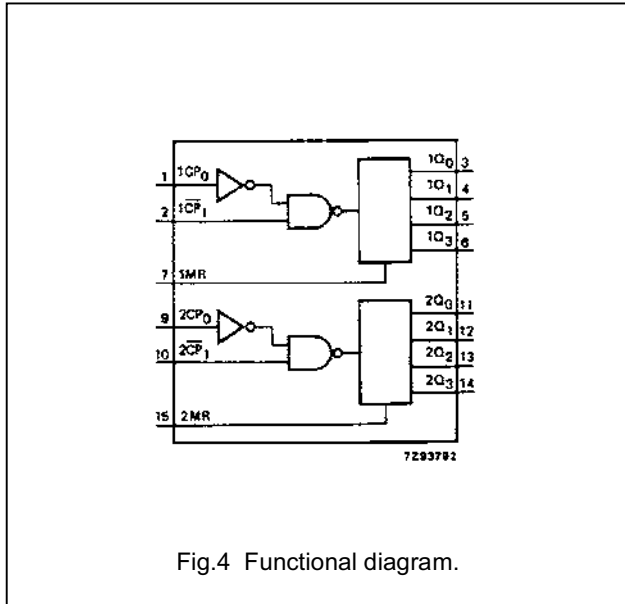

FUNCTION TABLE

nCP ₀	nCP ₁	MR	MODE
↑	H	L	counter advances
L	↓	L	counter advances
↓	X	L	no change
X	↑	L	no change
↑	L	L	no change
H	↓	L	no change
X	X	H	Q ₀ to Q ₃ = LOW

Notes

- H = HIGH voltage level
L = LOW voltage level
X = don't care
↑ = LOW-to-HIGH clock transition
↓ = HIGH-to-LOW clock transition

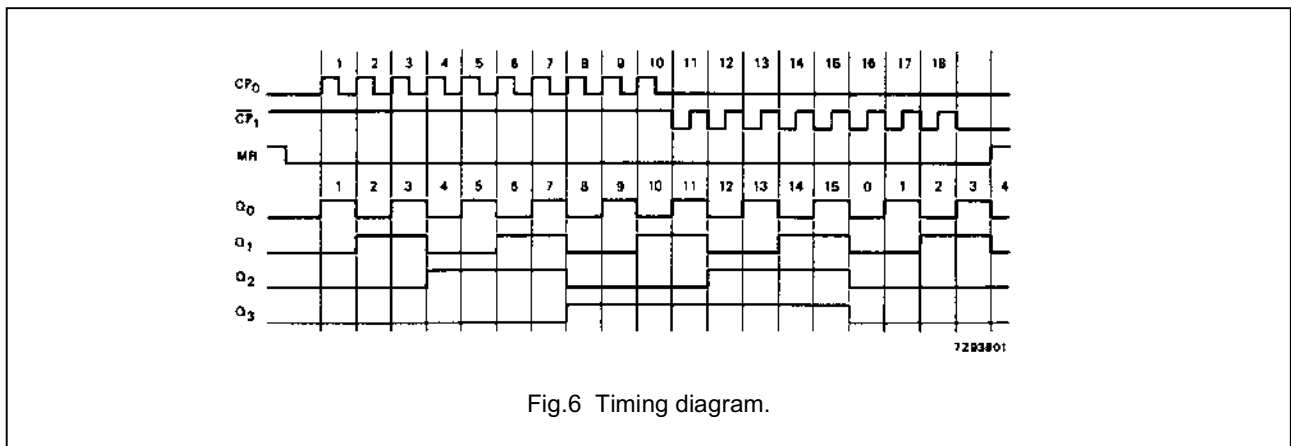
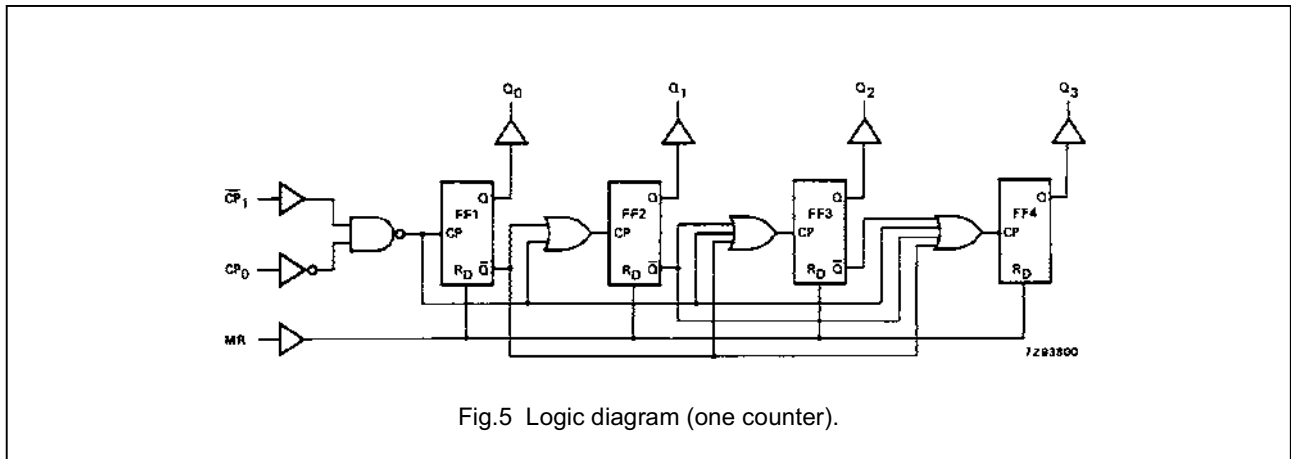

Dual 4-bit synchronous binary counter

74HC/HCT4520

DC CHARACTERISTICS FOR 74HC

For the DC characteristics see "74HC/HCT/HCU/HCMOS Logic Family Specifications".

Output capability: standard

I_{CC} category: MSI

AC CHARACTERISTICS FOR 74HC

GND = 0 V; t_r = t_f = 6 ns; C_L = 50 pF

SYMBOL	PARAMETER	T _{amb} (°C)						UNIT	TEST CONDITIONS		
		74HC							V _{CC} (V)	WAVEFORMS	
		+25			-40 to +85		-40 to +125				
		min.	typ.	max.	min.	max.	min.				max.
t _{PHL} / t _{PLH}	propagation delay nCP ₀ to nQ _n		77 28 22	240 48 41		300 60 51		360 72 61	ns	2.0 4.5 6.0	Fig.8
t _{PHL} / t _{PLH}	propagation delay nCP ₁ to nQ _n		77 28 22	240 48 41		300 60 51		360 72 61	ns	2.0 4.5 6.0	Fig.8
t _{PHL}	propagation delay nMR to nQ _n		44 16 13	150 30 26		190 38 33		225 45 38	ns	2.0 4.5 6.0	Fig.9
t _{THL} / t _{TLH}	output transition time		19 7 6	75 15 13		95 19 16		110 22 19	ns	2.0 4.5 6.0	Fig.8
t _w	clock pulse width HIGH or LOW	80 16 14	22 8 6		100 20 17		120 24 20		ns	2.0 4.5 6.0	Fig.7
t _w	master reset pulse width HIGH	120 24 20	39 14 11		150 30 26		180 36 31		ns	2.0 4.5 6.0	Fig.7
t _{rem}	removal time nMR to nCP ₀ ; nCP ₁	0 0 0	-28 -10 -8		0 0 0		0 0 0		ns	2.0 4.5 6.0	Fig.7
t _{su}	set-up time nCP ₁ to nCP ₀ ; nCP ₀ to nCP ₁	80 16 14	14 5 4		100 20 17		120 24 20		ns	2.0 4.5 6.0	Fig.8
f _{max}	maximum clock pulse frequency	6.0 30 35	19 58 69		4.8 24 28		4.0 20 24		MHz	2.0 4.5 6.0	Fig.7

Dual 4-bit synchronous binary counter

74HC/HCT4520

DC CHARACTERISTICS FOR 74HCT

For the DC characteristics see "74HC/HCT/HCU/HCMOS Logic Family Specifications".

Output capability: standard

I_{CC} category: MSI

Note to HCT types

The value of additional quiescent supply current (ΔI_{CC}) for a unit load of 1 is given in the family specifications.

To determine ΔI_{CC} per input, multiply this value by the unit load coefficient shown in the table below.

INPUT	UNIT LOAD COEFFICIENT
nCP ₀ , nCP ₁	0.80
nMR	1.50

AC CHARACTERISTICS FOR 74HCT

GND = 0 V; t_r = t_f = 6 ns; C_L = 50 pF

SYMBOL	PARAMETER	T _{amb} (°C)								UNIT	TEST CONDITIONS	
		74HCT									V _{CC} (V)	WAVEFORMS
		+25			-40 to +85		-40 to +125					
		min.	typ.	max.	min.	max.	min.	max.				
t _{PHL} / t _{PLH}	propagation delay nCP ₀ to nQ _n		28	53		66		80	ns	4.5	Fig.8	
t _{PHL} / t _{PLH}	propagation delay nCP ₁ to nQ _n		25	53		66		80	ns	4.5	Fig.8	
t _{PHL}	propagation delay nMR to nQ _n		16	35		44		53	ns	4.5	Fig.9	
t _{THL} / t _{TLH}	output transition time		7	15		19		22	ns	4.5	Fig.8	
t _W	clock pulse width HIGH or LOW	20	10		25		30		ns	4.5	Fig.7	
t _W	master reset pulse width HIGH	20	12		25		30		ns	4.5	Fig.7	
t _{rem}	removal time nMR to nCP ₀ ; nCP ₁	0	-8		0		0		ns	4.5	Fig.7	
t _{su}	set-up time nCP ₁ to nCP ₀ ; nCP ₀ to nCP ₁	16	6		20		24		ns	4.5	Fig.8	
f _{max}	maximum clock pulse frequency	30	58		24		20		MHz	4.5	Fig.7	

Dual 4-bit synchronous binary counter

74HC/HCT4520

AC WAVEFORMS

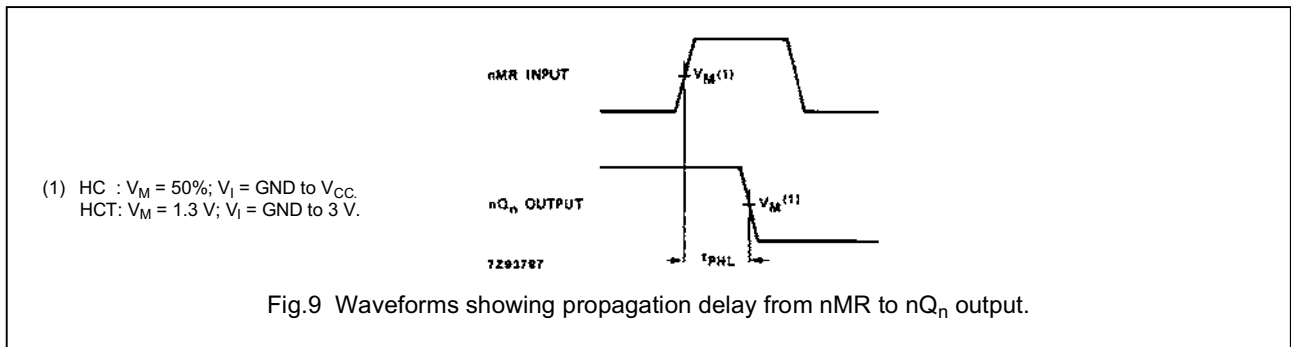
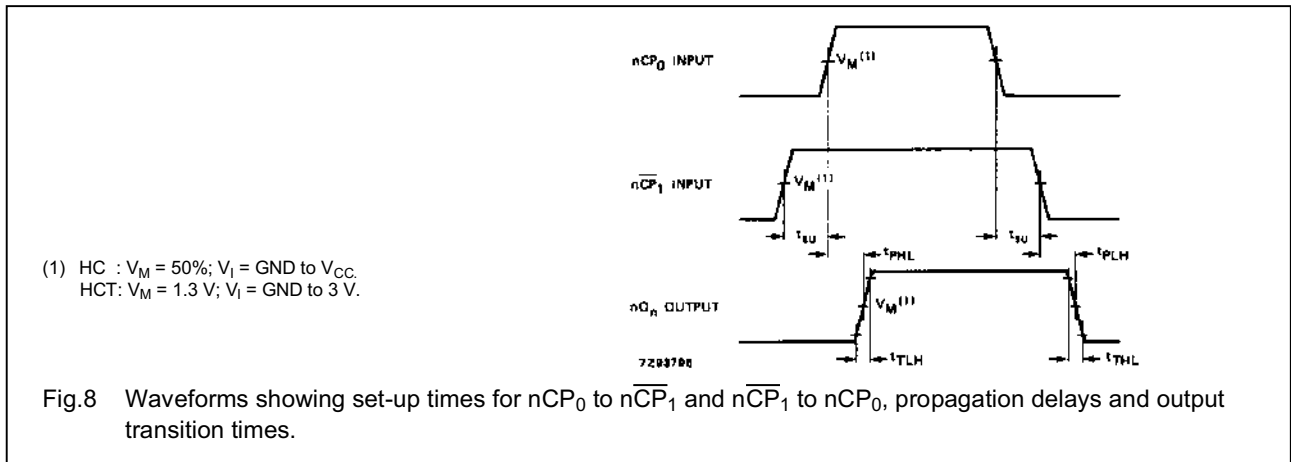
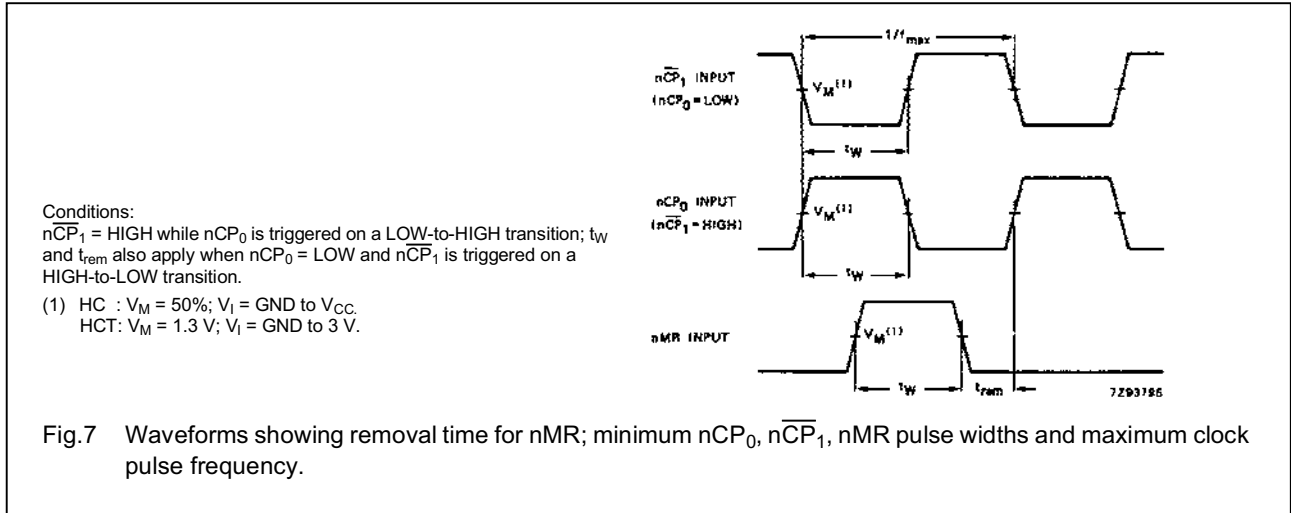

PACKAGE OUTLINES

See "74HC/HCT/HCU/HCMOS Logic Package Outlines".