

DATA SHEET

For a complete data sheet, please also download:

- The IC06 74HC/HCT/HCU/HCMOS Logic Family Specifications
- The IC06 74HC/HCT/HCU/HCMOS Logic Package Information
- The IC06 74HC/HCT/HCU/HCMOS Logic Package Outlines

74HC4049

Hex inverting high-to-low level shifter

Product specification
File under Integrated Circuits, IC06

December 1990

Hex inverting high-to-low level shifter

74HC4049

FEATURES

- Output capability: standard
- I_{CC} category: SSI

GENERAL DESCRIPTION

The 74HC4049 is a high-speed Si-gate CMOS device and is pin compatible with the "4049" of the "4000B" series. It is specified in compliance with JEDEC standard no. 7A.

The 74HC4049 provides six inverting buffers with a modified input protection structure, which has no diode connected to V_{CC} . Input voltages of up to 15 V may therefore be used.

This feature enables the inverting buffers to be used as logic level translators, which will convert high level logic to low level logic, while operating from a low voltage power supply. For example 15 V logic ("4000B series") can be converted down to 2 V logic.

The actual input switch level remains related to the V_{CC} and is the same as mentioned in the family characteristics. At the same time each part can be used as a simple inverter without level translation.

APPLICATIONS

- Converting 15 V logic ("4000B" series) down to 2 V logic.

QUICK REFERENCE DATA

GND = 0 V; $T_{amb} = 25\text{ }^{\circ}\text{C}$; $t_r = t_f = 6\text{ ns}$

SYMBOL	PARAMETER	CONDITIONS	TYPICAL	UNIT
			HC	
t_{PHL}/t_{PLH}	propagation delay nA to n \bar{Y}	$C_L = 15\text{ pF}$; $V_{CC} = 5\text{ V}$	8	ns
C_I	input capacitance		3.5	pF
C_{PD}	power dissipation capacitance per buffer	note 1	14	pF

Note

1. C_{PD} is used to determine the dynamic power dissipation (P_D in μW):

$$P_D = C_{PD} \times V_{CC}^2 \times f_i + \sum (C_L \times V_{CC}^2 \times f_o) \text{ where:}$$

f_i = input frequency in MHz

f_o = output frequency in MHz

C_L = output load capacitance in pF

V_{CC} = supply voltage in V

$\sum (C_L \times V_{CC}^2 \times f_o)$ = sum of outputs

ORDERING INFORMATION

See "74HC/HCT/HCU/HCMOS Logic Package Information".

Hex inverting high-to-low level shifter

74HC4049

PIN DESCRIPTION

PIN NO.	SYMBOL	NAME AND FUNCTION
1	V_{CC}	positive supply voltage
2, 4, 6, 10, 12, 15	$1\bar{Y}$ to $6\bar{Y}$	data outputs
3, 5, 7, 9, 11, 14	1A to 6A	data inputs
8	GND	ground (0 V)
13, 16	n.c.	not connected

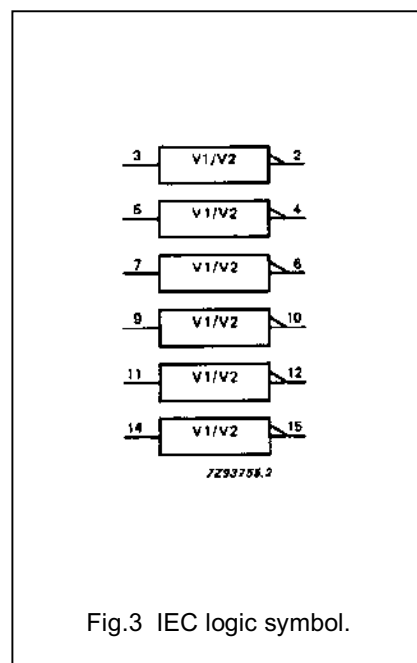
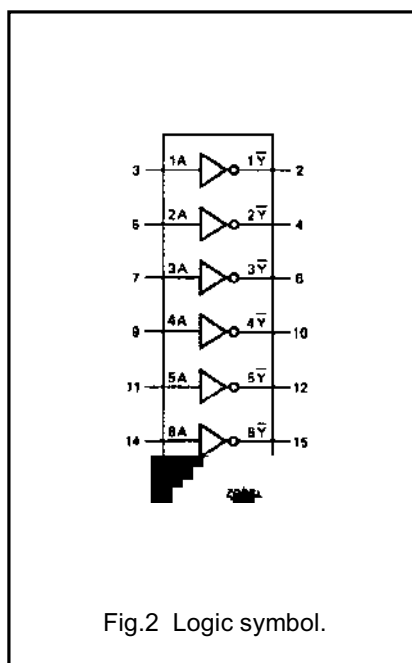
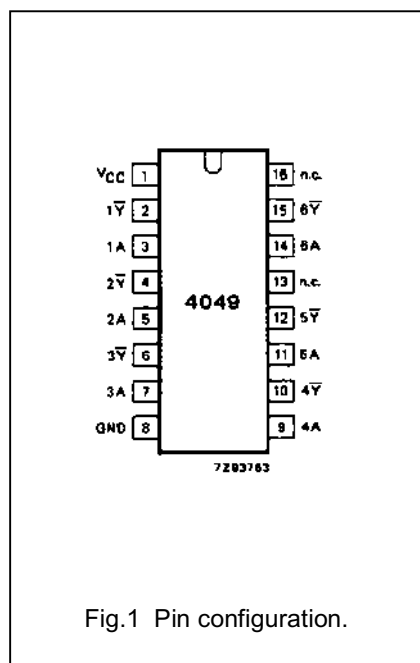

Hex inverting high-to-low level shifter

74HC4049

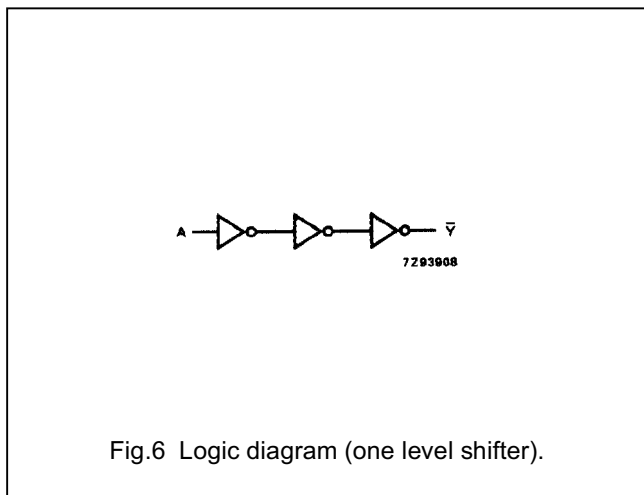
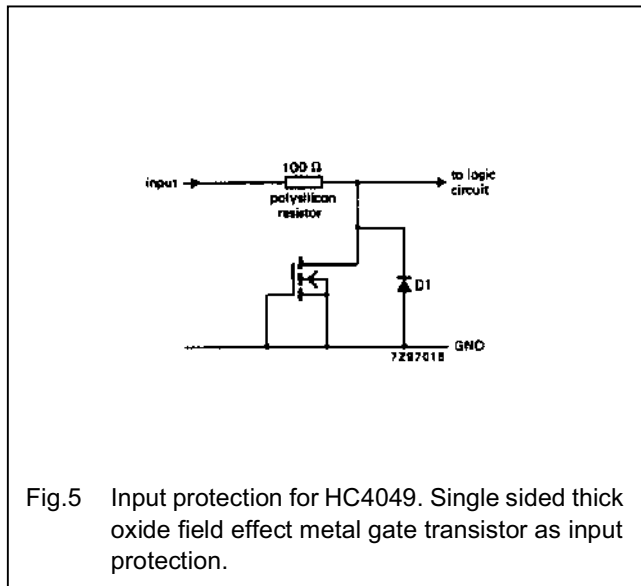
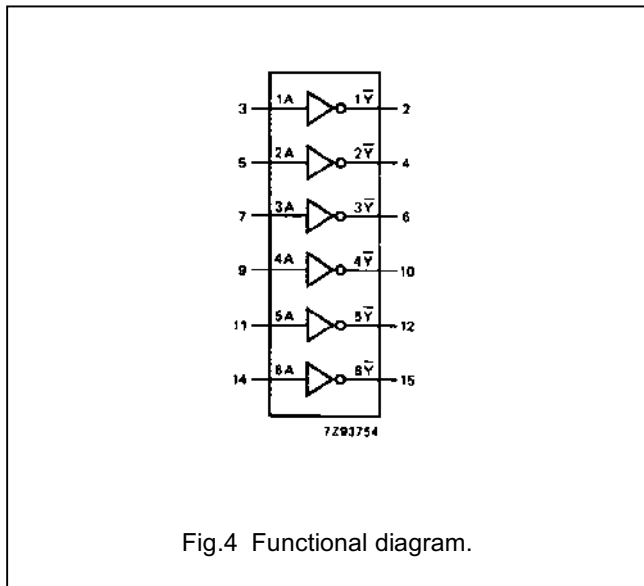

FUNCTION TABLE

INPUT	OUTPUT
nA	nY
L	H
H	L

Notes

- 1. H = HIGH voltage level
- L = LOW voltage level

Hex inverting high-to-low level shifter

74HC4049

RATINGS

Limiting values in accordance with the Absolute Maximum System (IEC 134)

Voltages are referenced to GND (ground = 0 V)

SYMBOL	PARAMETER	MIN.	MAX.	UNIT	CONDITIONS
V_{CC}	DC supply voltage	-0.5	+7	V	
V_{IK}	DC input voltage range	-0.5	+16	V	
$-I_{IK}$	DC input diode current		20	mA	for $V_I < -0.5$ V
$\pm I_{OK}$	DC output diode current		20	mA	for $V_O < -0.5$ V or $V_O > V_{CC} + 0.5$ V
$\pm I_O$	DC output source or sink current - standard outputs		25	mA	for -0.5 V $< V_O < V_{CC} + 0.5$ V
$\pm I_{CC}$; $\pm I_{GND}$	DC V_{CC} or GND current for types with: - standard outputs		50	mA	
T_{stg}	storage temperature range	-65	+150	°C	
P_{tot}	power dissipation per package				for temperature range: -40 to +125 °C 74HC
	plastic DIL		750	mW	above +70 °C: derate linearly with 12 mW/K
	plastic mini-pack (SO)		400	mW	above +70 °C: derate linearly with 8 mW/K

RECOMMENDED OPERATING CONDITIONS

SYMBOL	PARAMETER	74HC			UNIT	CONDITIONS
		min.	typ.	max.		
V_{CC}	DC supply voltage	2.0	5.0	6.0	V	
V_I	DC input voltage range	GND	-	15	V	
T_{amb}	operating ambient temperature range	-40		+85	°C	see DC and AC characteristics
T_{amb}	operating ambient temperature range	-40		+125	°C	
t_r, t_f	input rise and fall times		6.0	1000 500 400 650 1000	ns	$V_{CC} = 2.0$ V; $V_{IN} = 2.0$ V $V_{CC} = 4.5$ V; $V_{IN} = 4.5$ V $V_{CC} = 6.0$ V; $V_{IN} = 6.0$ V $V_{CC} = 6.0$ V; $V_{IN} = 10.0$ V $V_{CC} = 6.0$ V; $V_{IN} = 15.0$ V

Hex inverting high-to-low level shifter

74HC4049

DC CHARACTERISTICS FOR 74HC

Voltages are referenced to GND (ground = 0 V)

SYMBOL	PARAMETER	T _{amb} (°C)							UNIT	TEST CONDITIONS		
		74HC								V _{CC} (V)	V _I	OTHER
		+25			-40 to +85		-40 to +125					
		min.	typ.	max.	min.	max.	min.	max.				
V _{IH}	HIGH level input voltage	1.5 3.15 4.2	1.3 2.4 3.1		1.5 3.15 4.2		1.5 3.15 4.2		V	2.0 4.5 6.0		
V _{IL}	LOW level input voltage		0.7 1.8 2.3	0.5 1.35 1.8		0.5 1.35 1.8		0.5 1.35 1.8	V	2.0 4.5 6.0		
V _{OH}	HIGH level output voltage all outputs	1.9 4.4 5.9	2.0 4.5 6.0		1.9 4.4 5.9		1.9 4.4 5.9		V	2.0 4.5 6.0	V _{IH} or V _{IL}	-I _O = 20 μA -I _O = 20 μA -I _O = 20 μA
V _{OH}	HIGH level output voltage standard outputs	3.98 5.48			3.84 5.34		3.7 5.2		V	4.5 6.0	V _{IH} or V _{IL}	-I _O = 4.0 mA -I _O = 5.2 mA
V _{OL}	LOW level output voltage all outputs			0.1 0.1 0.1		0.1 0.1 0.1		0.1 0.1 0.1	V	2.0 4.5 6.0	V _{IH} or V _{IL}	I _O = 20 μA I _O = 20 μA I _O = 20 μA
V _{OL}	LOW level output voltage standard outputs			0.26 0.26		0.33 0.33		0.4 0.4	V	4.5 6.0	V _{IH} or V _{IL}	I _O = 4.0 mA I _O = 5.2 mA
± I _I	input leakage current			0.1		1.0		1.0	μA	6.0	V _{CC} or GND	
				0.5		5.0		5.0	μA	2.0 to 6.0	15 V	
I _{CC}	quiescent supply current			2.0		20.0		40.0	μA	6.0	15 V or GND	

Hex inverting high-to-low level shifter

74HC4049

AC CHARACTERISTICS FOR 74HC

GND = 0 V; $t_r = t_f = 6$ ns; $C_L = 50$ pF

SYMBOL	PARAMETER	T_{amb} (°C)						UNIT	TEST CONDITIONS		
		74HC							V_{CC} (V)	WAVEFORMS	
		+25			-40 to +85		-40 to +125				
		min.	typ.	max.	min.	max.	min.				max.
t_{PHL} / t_{PLH}	propagation delay nA to n \bar{Y}		28 10 8	85 17 14		105 21 18		130 26 22	ns	2.0 4.5 6.0	Fig.7
t_{THL} / t_{TLH}	output transition time		19 7 6	75 15 13		95 19 16		110 22 19	ns	2.0 4.5 6.0	Fig.7

AC WAVEFORMS

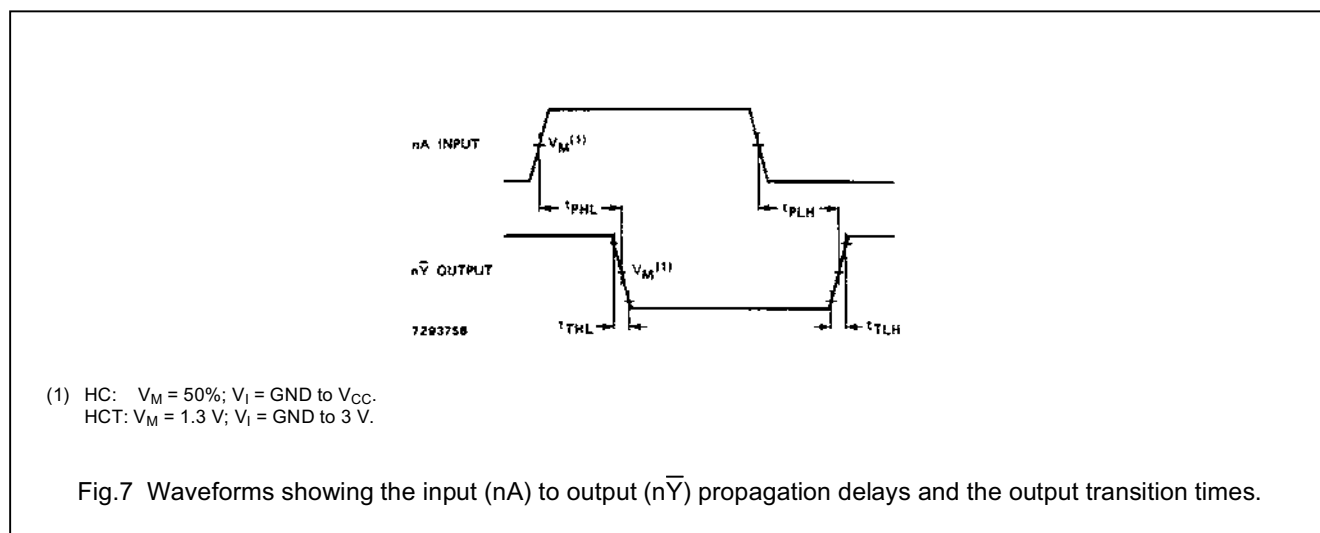

PACKAGE OUTLINES

See "74HC/HCT/HCU/HCMOS Logic Package Outlines".